Meridian 1

Buffer Interface/Protocol Converter

Description

Document Number: 553-2801-100

Document Release: Standard 5.00

Date: April 2000

Copyright ©1989–2000 Nortel Networks
All Rights Reserved

Printed in Canada

Information is subject to change without notice. Nortel Networks reserves the right to make changes in design or components as progress in engineering and manufacturing may warrant. This equipment has been tested and found to comply with the limits for a Class A digital device pursuant to Part 15 of the FCC rules, and the radio interference regulations of Industry Canada. These limits are designed to provide reasonable protection against harmful interference when the equipment is operated in a commercial environment. This equipment generates, uses and can radiate radio frequency energy, and if not installed and used in accordance with the instruction manual, may cause harmful interference to radio communications. Operation of this equipment in a residential area is likely to cause harmful interference in which case the user will be required to correct the interference at their own expense.

SL-1 and Meridian 1 are trademarks of Nortel Networks.

Revision history

April 2000

Standard 5.00. This is a global document and is up-issued for X11 Release 25.0x.

August 1996

Standard 4.00. Reissued for X11 Release 22.0x.

December 1994

Standard 3.00. Reissued to include editorial changes and indexing.

December 1991

Standard 2.00. This document is reissued to include technical content updates.

December 1989

Standard 1.00. Reissued for compliance with Nortel Networks standard 164.0 and to include updates for X11 Release 15.

Contents

General information	7
Reference list	7
Test equipment	8
References	9
Description	11
Interface circuits and protocols	17
BIPC protocol requirements	17
BIPC initialization	18
Link control	18
Message control	20
Message envelopes	20
Message protocol and responses	21
Message priorities	21
Examples	23
Installation	29
Reference list	29
Mounting location	29
Unpacking and inspection	29
Option settings	29
SDI options	30
BIPC options	31
Cable connections	33

Operational checks	33
Summary	34
Operating procedures	41
Placing in service	41
Restoring service	41
Repair procedure	41
Ordering information	43
Specifications	45
Mechanical	45
BIPC (A0297075)	45
Power Supply (A0297998)	45
Electrical	46
BIPC (A0297075)	46
Power Supply (A0297998)	46
RS-232-C interface	46
List of terms	49
Index	51

General information

Reference list

The following are the references in this section:

- *Background Terminal Facility Description (553-2311-316)*
- *X11 Features and Services (553-3001-306)*
- *X11 Administration (553-3001-311)*

This document contains descriptions, installation and operating procedures, ordering information, and specifications for the Buffer Interface/Protocol Converter (BIPC).

Before starting the Buffer Interface/Protocol Converter (BIPC) installation, coordination with LODGISTIX or your In House System (IHS) is necessary. The IBM series 1 hardware and software must be modified as per specifications from LODGISTIX or IHS for PBX Interface. Operating without the correct modifications may cause the Buffer Interface/Protocol Converter (BIPC) to fail or damage the hardware.

The BIPC provides the necessary interface and communication protocol for connecting a customer-provided Property Management System (PMS) through a Serial Data Interface (SDI) port to the switch. The PMS could consist of a LODGISTIX or In House System (IHS) computer.

When installed (Figure 1), the BIPC provides

- two bidirectional, RS-232-C ports for connecting to a Serial Data Interface (SDI) port on one side, and the Property Management System (PMS) data port on the other side

- data buffering at both ports for the transfer of serial message data between the Meridian 1 and the Property Management System (PMS)
- the communication protocol required to automate communication between the Meridian 1 and PMS

Note: In this document, Meridian 1 refers to SL-1 systems as well as the Meridian 1 system options available with X11 release 15 and later.

You can use the BIPC with all Meridian 1 systems. A typical application is for Room and Maid Status control on a system equipped with the hospitality features.

Figure 1
Simplified BIPC installation diagram

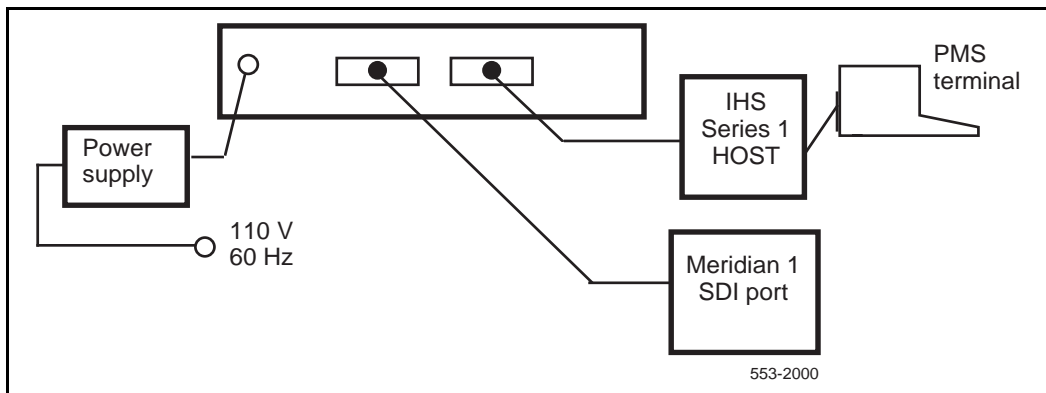

Test equipment

The following test equipment is recommended for installation and troubleshooting:

- 1 Async datascopes
- 1 ASCII terminal or TTY

References

Refer to the following publications for details concerning hospitality features:

- *Background Terminal Facility Description (553-2311-316)*
- *X11 Features and Services (553-3001-306)*
- *X11 Administration (553-3001-311)*

For details of the standards and specifications referred to in this document, consult the following documents:

- EIA Standard RS-232-C
Interface between Data Terminal Equipment (DTE) and Data Communication Equipment (DCE) employing serial binary data interchange
- CCITT Recommendation V.24
List of definitions for interchange circuits between Data Terminal Equipment (DTE) and Data Circuit-terminating Equipment (DCT)
- ISO Standard 2110-1980
Data Communication, 25-pin DTE/DCE interface connector and pin assignments

Note: EIA RS-232-C and CCITT V.24 are equivalent standards.

Description

The BIPC is a single unit in a metal housing with an external power supply. The overall dimensions of the unit are approximately 14 x 2.5 x 7 in. (356 x 64 x 178 mm).

The front panel of the BIPC has the following characteristics:

- two LEDs, labeled PORT A and PORT B, to indicate when data is received into the applicable interface port of the BIPC
- one LED to indicate when power is applied to the BIPC
- a RESET push-button switch for initializing the BIPC operation

Two 25-pin female connectors are mounted on the back panel and labeled A and B. These are the RS-232-C interface connectors for the Meridian 1 and PMS connections.

The top cover of the unit is secured with four screws. You can remove the top cover to access the option switches and jumpers, and other components mounted within the unit. Figure 2 shows the layout of the components.

Power for the BIPC is connected from an external power supply. The 5-wire cable from the power supply is connected to the power connector at the back right corner of the BIPC. It provides + 5, + 12, -12 V dc, ground and chassis ground connections.

The power supply dimensions are 4.75 x 2.75 x 2.25 in. (121 x 70 x 57 mm). See Figure 3. The unit is equipped with the following two power cables:

- a 3-wire, input power cord approximately 6 ft (1.8 m) long, with a standard, UL/CSA approved plug for connection to a standard 3-pin, 110 V, 60 Hz, AC power outlet
- a 5-wire output power cable, approximately 7 ft (2.1 m) long, with strain relief and a connector for connection between the power supply and the BIPC

Note: RS-232-C cables to interface to and from the BIPC are not included and must be supplied locally.

The BIPC provides the interface between a Meridian 1 and a PMS. It can operate at different data rates, use different data handling characteristics, or have similarly incompatible serial data interface (SDI) circuits. The BIPC is factory set for 9600 baud.

The RS-232-C interfaces between the circuits and the buffering needed for the interchange of serial data between the two data terminals. The functions and protocols automate the transfer of messages across the BIPC interfaces and the data links between the data terminals.

All BIPC functions are controlled by a Z80 microprocessor. Operating system storage is provided by an EPROM device (Figure 2). BIPC initialization occurs when power is applied to the unit, or when the RESET switch on the front panel is pressed.

The two 25-pin female connectors (DB25S), labeled A and B, are compatible with ISO Standard 2110-1980 for pin configuration and numbering. They provide the physical (electrical/mechanical) interface ports for the data links to the Meridian 1 and PMS. The connectors, and the RS-232-C circuits provided on them, are illustrated in Figure 4. The two ports can be operated at independent data rates up to 9600 baud. However, 9600 baud on the Meridian 1 port and 1200 baud on the PMS port are used in this application. The word format (code structure and buffer control) of the PMS port is selectable, but the port is hardwired for 8-bit data, one stop bit and no parity. Data buffering to facilitate transfer of data between the independently operated ports is provided by 2 K of RAM (Figure 2).

Figure 2
BIPC component layout diagram

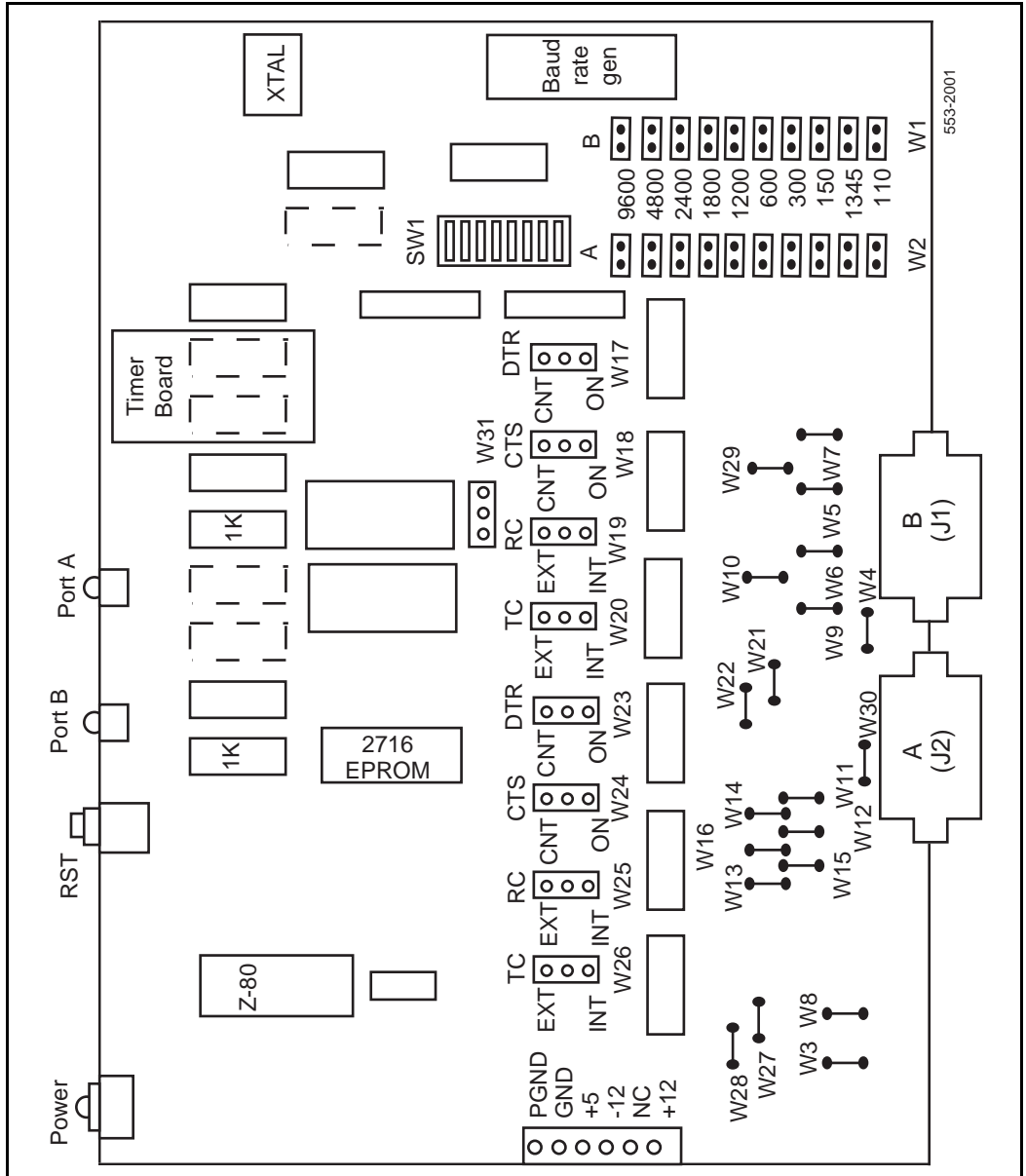
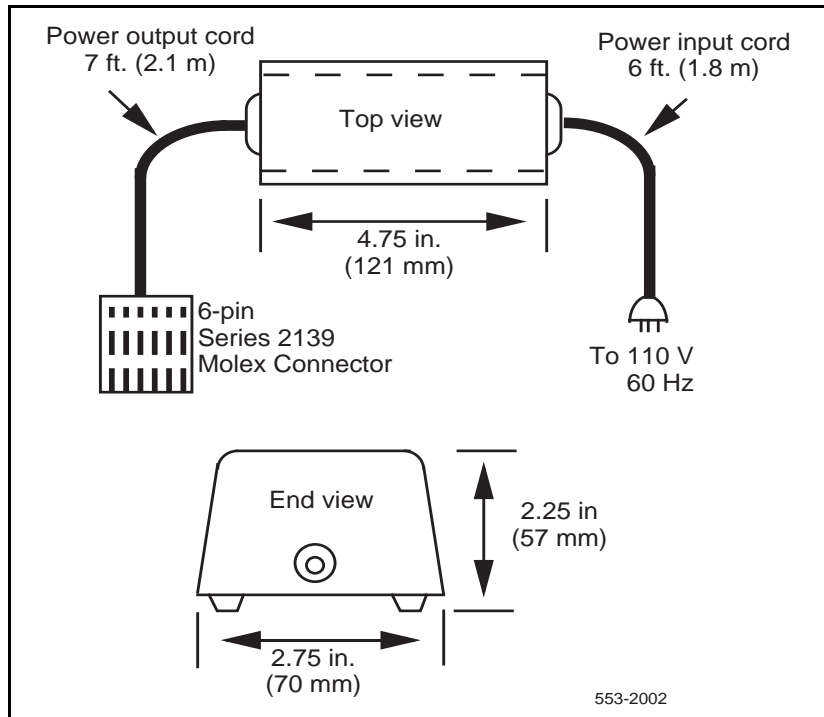
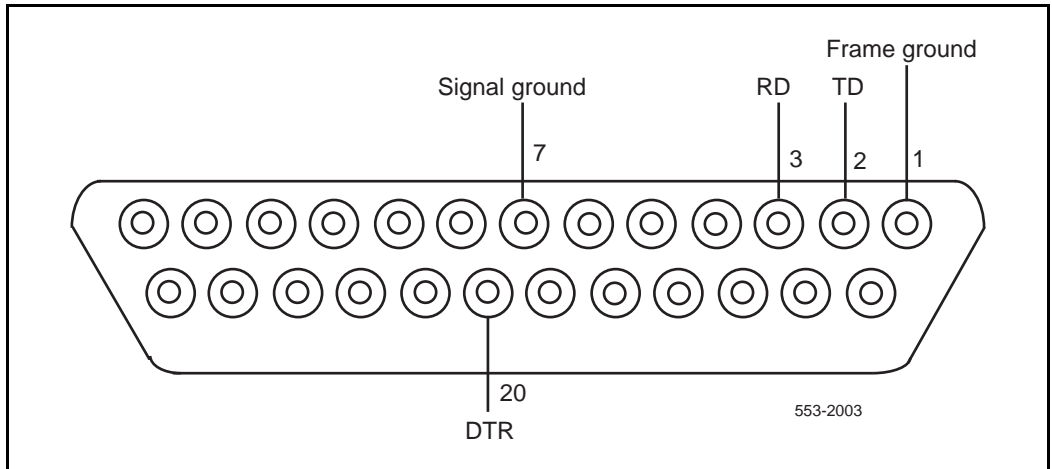

Figure 3
Power supply (A0297998)



Both BIPC ports are wired to represent data terminal equipment (DTE). For normal connections to the data communications equipment (DCE) at the Meridian 1 and the PMS, RS-232-C cables fitted with 25-pin connectors are required. The cables must include straight-through connections between pins 1, 2, 3, 7, and 20 on the two connectors to provide RS-232-C interchange circuits AA, AB, BA, BB, and CD between the BIPC and the DCE (Figure 5).

Figure 4
BIPC interface connectors and interchange circuits



The BIPC provides the necessary conversions between the different protocols used by the two data ports to control the flow of serial data across the data links. In addition to logic for independent control of the physical links between the BIPC and the two data terminals, the BIPC also provides message handling protocol between the PMS and the BIPC. Because the link from the SDI port does not use message handling protocol as such, the BIPC adds the required protocol characters to messages originating from the Meridian 1, and conversely strips the control protocol from PMS-originated messages before transferring the message body to the Meridian 1.

The BIPC also provides error control functions as part of the message handling. Since the SDI ports do not use parity checks, the BIPC adds parity bits to the serial data sent to the PMS if parity is enabled on the option switch (SW1). It also detects parity bits in the data stream from the PMS, performs Block Character Checks (BCC) for error detection and then removes the parity bits before sending the message body to the Meridian 1. If errors are detected, the BIPC initiates error recovery procedures.

Interface circuits and protocols

BIPC protocol requirements

The BIPC provides the following capabilities:

- transmits messages originated by either the Meridian 1 or the PMS across the BIPC interface
- overrides PMS originated messages by Meridian 1-originated messages, if the messages are originated simultaneously. Messages are interrupt driven on the Meridian 1 side and protocol driven on the PMS side.
- does not reformat the message body
- uses asynchronous, RS-232-C data handling at up to 9600 baud
- adds one parity bit to each Meridian 1-generated 8-bit data byte
- strips parity bits from the PMS generated data stream
- uses message control (message envelope) characters at the BIPC/PMS interface as defined in Table 1
- uses interchange protocol, message envelope, and responses at the BIPC/PMS interface as described later

The protocols used between the two data terminals can be classed as follows:

- Link Control to handle the establishment, take down, and maintenance of the data links, and the flow of serial data across the links
- Message Control to handle the exchange of the actual message body across the BIPC interfaces between the two terminals

BIPC initialization

The BIPC is initialized when power is applied, or when the RESET button is pressed. The BIPC sends a carriage return <CR> to the Meridian 1 and waits until it responds with the period (.) prompt character (hex 2E). The BIPC dumps any characters received before the prompt. When the prompt character is received, a flag is set in the BIPC indicating that the Meridian 1 is active. When an Enquiry (ENQ) is received from the PMS, the flag is checked. If the flag is set, the BIPC responds to the PMS with Acknowledged (ACK). If the flag is not set, the BIPC responds with Not Acknowledged (NAK).

Link control

The data interchange between the BIPC and the two data ports (Meridian 1 and PMS) is on data links using RS-232-C link control functions (Figure 5).

The RS-232-C interchange circuits required at each of the two interface ports appear in Figure 5. The figure includes RS-232-C, CCITT V.24, and Meridian 1 SDI circuit designations for cross-referencing and to show the functions of the circuits in BIPC operation. For more details on the interchange circuits, refer to the applicable standard (RS-232-C or CCITT V.24).

The Specifications section of this document summarizes the electrical characteristics of the interface circuits for Meridian 1/PMS applications.

Several options provide logical control of the data links. You select the options independently by changing the jumpers on the ports (Figure 14). A PC board layout drawing is necessary for changing the jumpers.

Figure 5
BIPC interface connections and functions

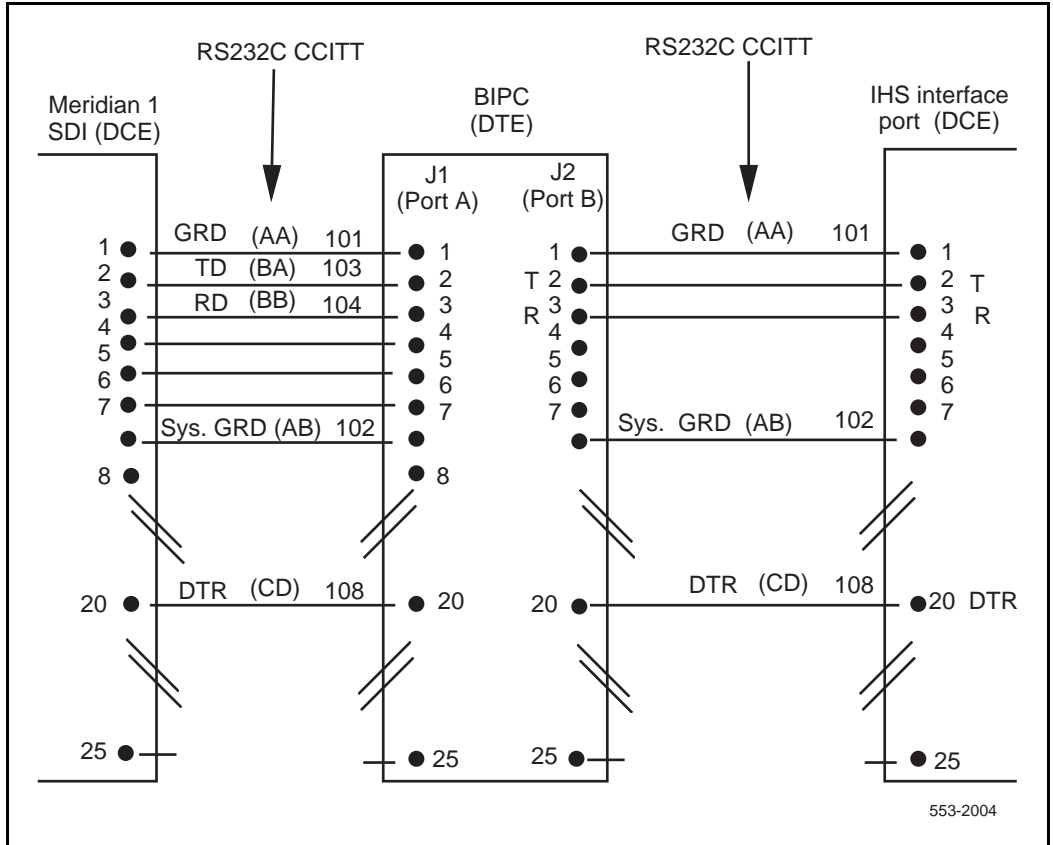

The following options are available:

- Data Terminal Ready (DTR) (on connector pin 20) is strapped continuously on.
- Block Character Checks (BCC) is either on or off. With PMS, this option is set on by the factory and is set off only if the PMS cannot use or generate BCC error control.
- Word format Port A (to the Meridian 1) is always configured for a word format of one start bit, 8 databit, no parity, and 1 stop bit. Port B (to the PMS) word format is switch selectable (switch module SW1). The word format appears in Figure 6. The BIPC is factory set for 7 data bits, even parity, 1 start bit, and 1 stop bit.

Message control

Message envelopes

BIPC/PMS link The envelope for messages between the BIPC and the PMS uses the ASCII-encoded control characters listed in Table 1. In addition, each message block terminates with a Block Character Checks (BCC) character. The BCC maintains message integrity, and is an Exclusive-OR of all bytes following the Start of Text (STX), including the End of Text (ETX). The general message format from the sender follows:

ENQ STX (message body) ETX BCC

BIPC/ Meridian 1 link The Meridian 1 does not support a message protocol. Messages are simply transmitted into the Meridian 1 when it is ready, as indicated by the prompt character. The input message to the Meridian 1 is Message <CR>, which it echoes back to the BIPC (echoplex). The terminating <CR> indicates the end of a message. The protocol from the Meridian 1 to the BIPC follows:

CR	LF	nul	nul	nul	nul	nul	nul	Message Body
CR	LF	nul	nul	nul	nul	nul	nul	Message Body
CR	LF	nul	nul	nul	nul	nul	nul	(prompt)

Note: The number of message lines sent before the prompt depends on the command and the Meridian 1 software.

Message protocol and responses

The BCC follows the End of Text (ETX) character in the transmission, and the receiver immediately performs a verification check. If the BCC is correct, the receiver responds with Acknowledged (ACK). If the BCC does not match, the receiver responds with Not Acknowledged (NAK).

Figure 6
Word format

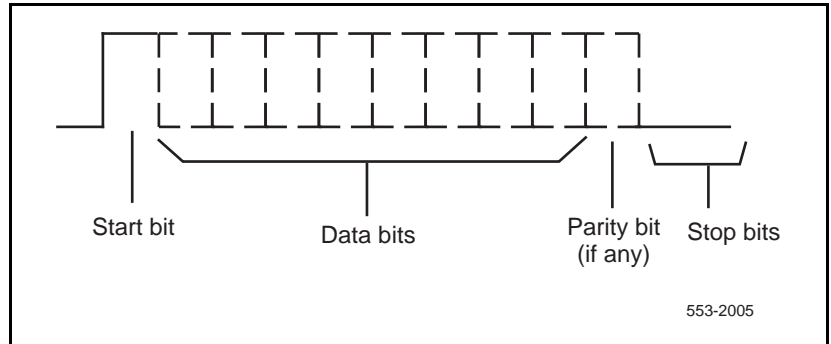

The port is always configured for 8 data bits, no parity, and 1 stop bit. The PMS port word format is switch selectable.

The sender does not transmit a new message until it either receives an Acknowledged (ACK) response to the previous message, or until it makes three attempts (ENQ) to send the message and receive an ACK. If the required ACK is not received after three tries or within a 20-second delay from the time the ENQ is received, the sender flushes the message.

Message priorities

A receiver may not interrupt a transmitter in the middle of a message. If the PMS is sending to the BIPC, the BIPC waits until it has responded with an ACK or Not Acknowledged (NAK) before sending any character. Similarly, if the BIPC is sending to the PMS, the PMS waits until it responds with ACK or NAK before sending any characters to the BIPC. However, a one-second time out between characters violates the message specifications and allows the receiver to terminate reception of that message.

Table 1
Message control and special character definitions

Character	HEX code	Definitions
Control characters		
ENQ	05	Enquiry: solicits a response from the other terminal — from the sender, asking the receiver if it is ready to receive a message — from the receiver, asking the sender to send or resend a message
STX	02	Start of Text: message body follows
ETX	03	End of Text: end of message body
BCC		Block Character Check (optional)
ACK	06	Acknowledge: affirmative response from the receiver to the sender (if BCC is used, ACK also indicates BCC check matches)
NAK	15	Not-Acknowledged: negative response from the receiver to the sender (for example, not ready to receive a message or a block of data received with errors requires retransmission)
Special characters		
<CR>	0D	carriage return (or equivalent)
If	0A	line feed (or equivalent)
.	2E	ASCII character period (prompt character for Meridian 1)
00	00	Null (nu) character
xx		represents any hex number

Figure 7
BIPC connection diagram with communication channels

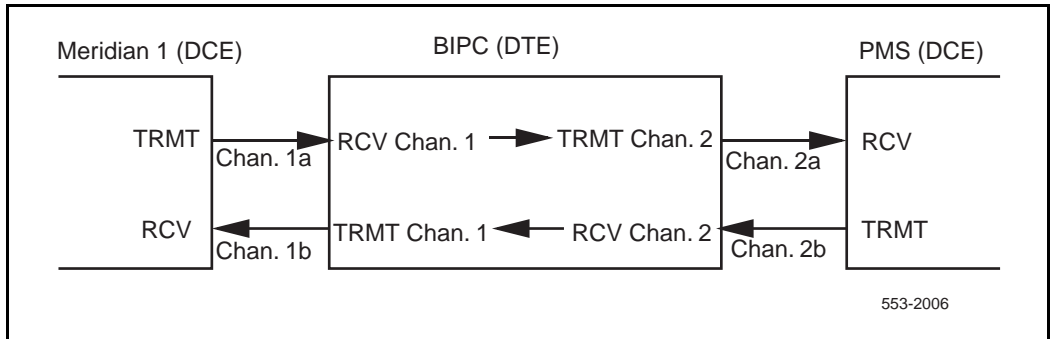

Examples

The examples appearing in Figures 8 through 12 illustrate applications of the message protocols under both normal and error conditions. The diagram in Figure 7 illustrates the message channels implied in these examples:

- Figure 8 Valid transaction example
 (message from PMS to Meridian 1)
- Figure 9 Invalid format example
 (control character in message body from PMS to BIPC)
- Figure 10 Transaction with error example
 (BCC mismatch in the BIPC to PMS message)
- Figure 11 Valid transaction example
 (single message from Meridian 1 to PMS)
- Figure 12 Valid transaction example
 (multiple messages from Meridian 1 to BIPC)

Figure 8
Valid transaction example (message from PMS to Meridian 1)

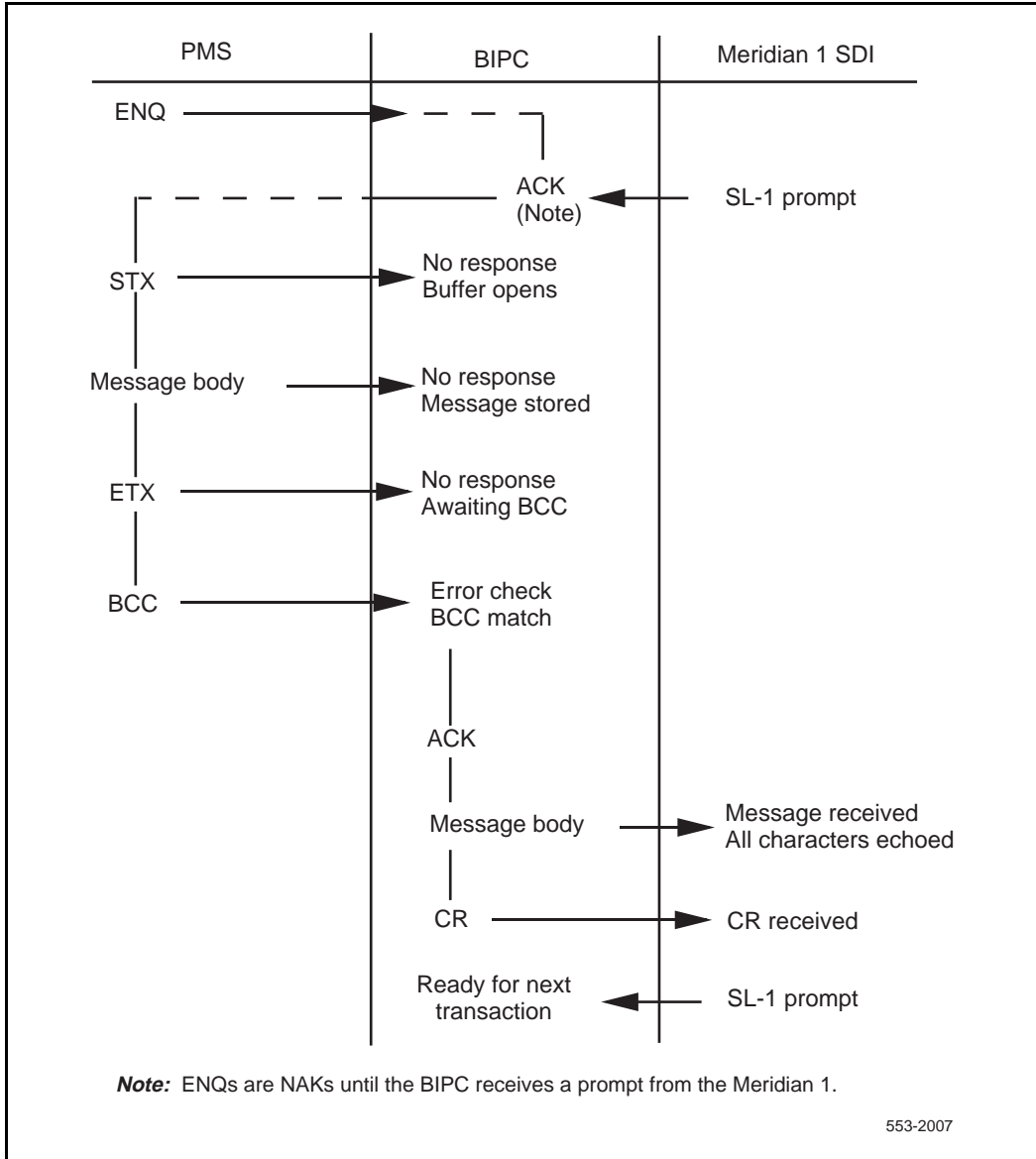

Figure 9
Invalid format example (control character in message body)

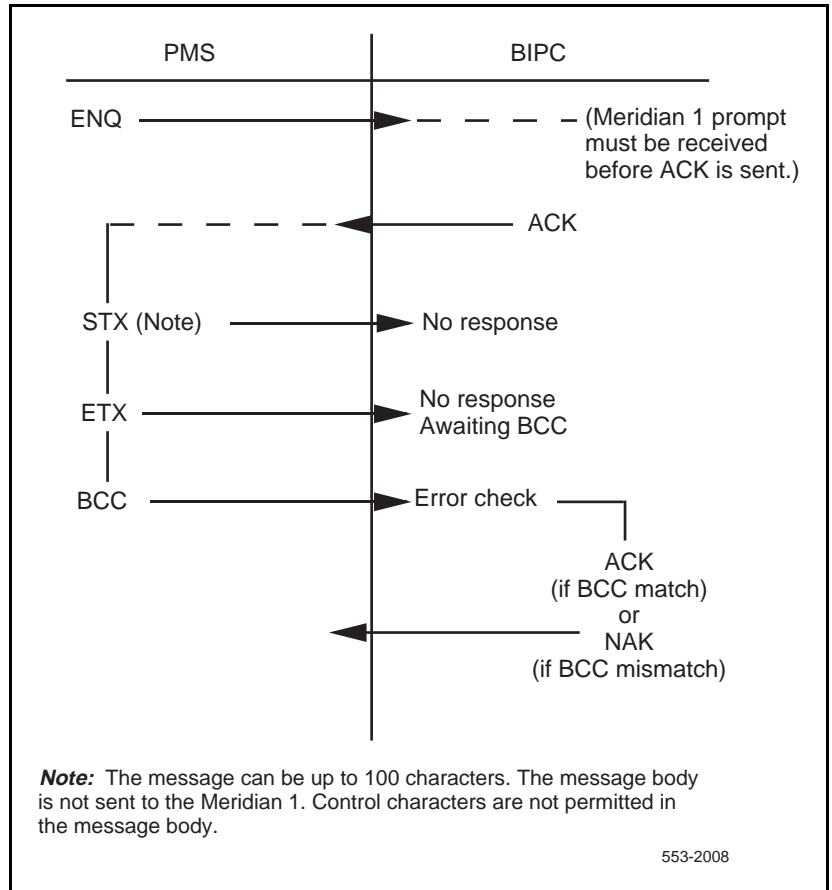

Figure 10
Transaction with error (BCC mismatch in the BIPC to PMS message)

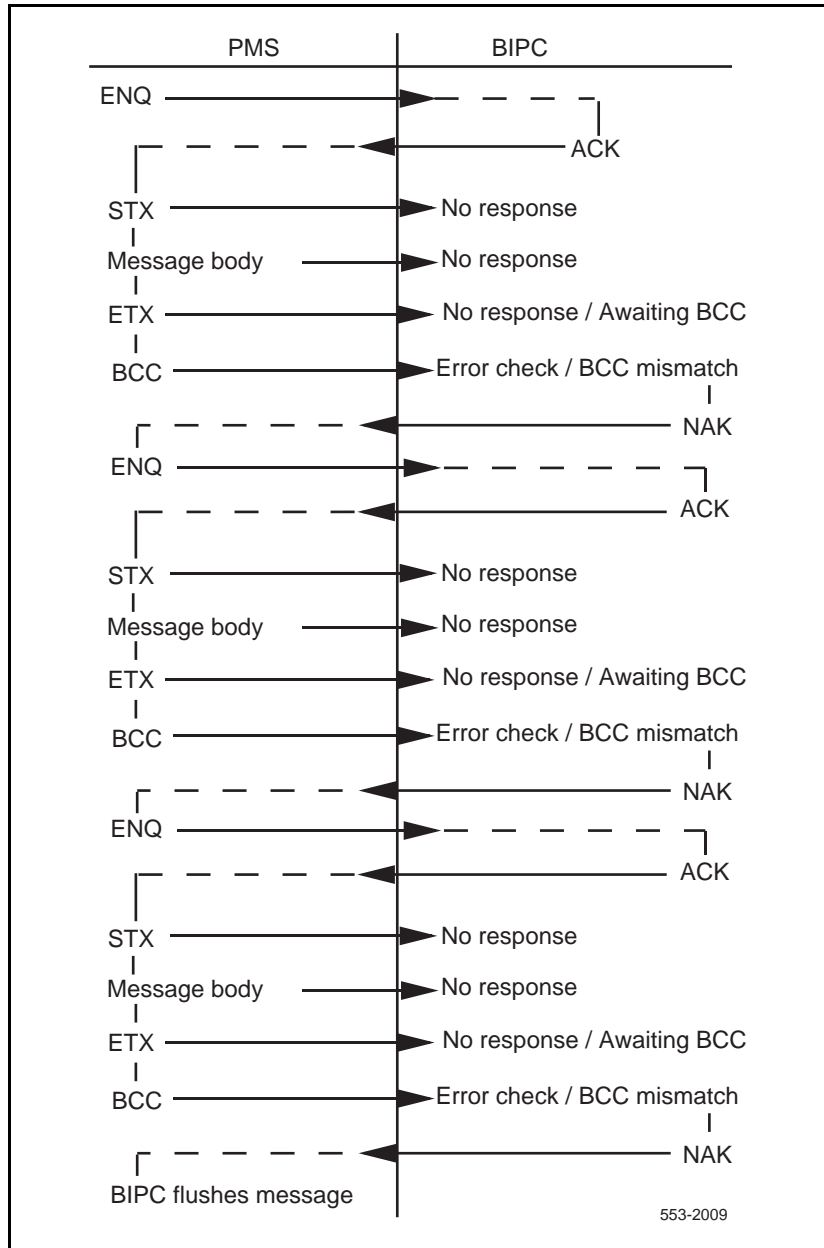

Figure 11
Valid Transaction (a single message from Meridian 1 to PMS)

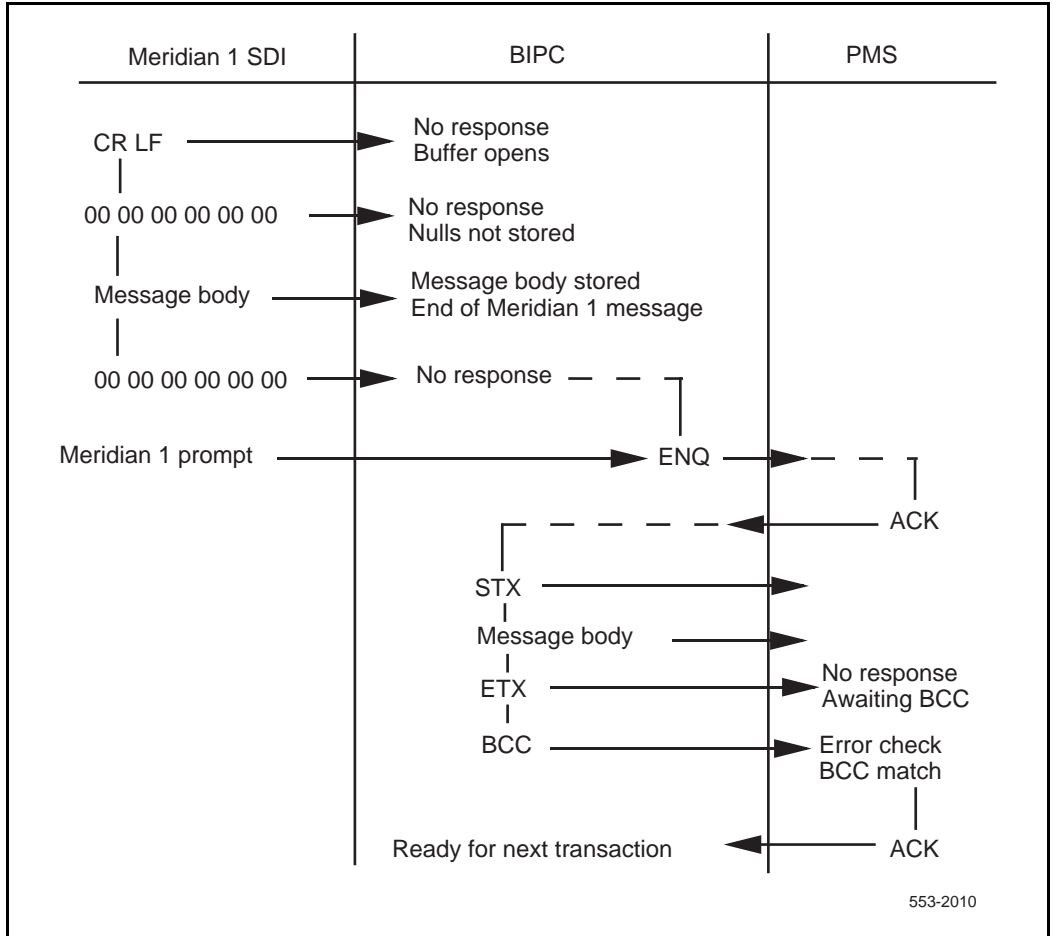
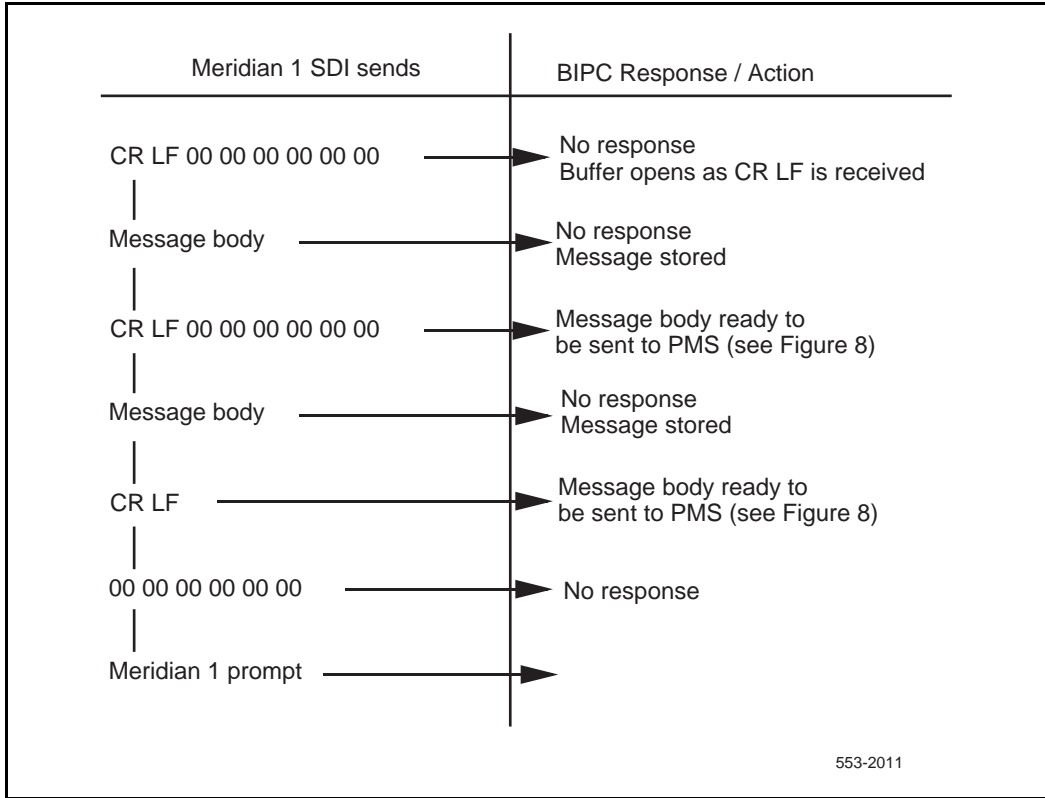

Figure 12
Valid Transaction (multiple messages from Meridian 1 to BIPC)



Installation

Reference list

The following are the references in this section:

- *Circuit Card Installation and Testing (553-3001-211)*

Mounting location

Mount the BIPC at any convenient location that meets or exceeds the following requirements:

- The cable length from the BIPC to the Meridian 1 SDI and to the PMS must not exceed 50 ft (15 m). If the distance is greater than 50 ft, use a short-haul modem or a line driver.
- The power supply (Figure 13) must be located so that the BIPC is within reach of the output cable (approximately 7 ft. [2.1 m]). A 110/120 V, 60 Hz, 3-pin power receptacle is within reach of the power supply power cord (6 ft. [1.8 m]).

To prepare the BIPC mounting location, clear sufficient space for setting the BIPC and the power supply on a flat surface approximately 15 x 8 in. (381 x 203 mm) for the BIPC and 5.5 x 3 in. (140 x 76 mm) for the power supply. A recommended location for the BIPC is on the top of the Meridian 1 cabinet, with the power supply beside or on top of the BIPC.

Unpacking and inspection

Unpack and inspect the equipment as detailed in Procedure 1 on page 35.

Option settings

Use the steps in Procedure 2 on page 35 for selecting the options.

SDI options

Set the address and speed switches on the SDI circuit pack. See *Circuit Card Installation and Testing (553-3001-211)* for the settings for your particular SDI card.

Figure 13
BIPC power cabling

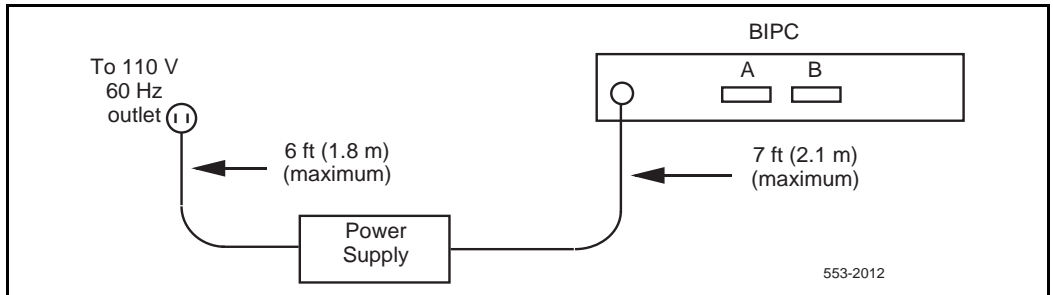

Note: The address is determined locally, and can be any number (00 to 15) not previously assigned to another SDI port.

BIPC options

Option switches and jumpers are located on the BIPC as shown in Figure 14. The options are on SW 1 as seen in Figure 3. Set the jumper on W2 (A) to the data rate of the Meridian 1 (9600 bps, for example). Set the jumper on W1 (B) to the data rate of the PMS (1200 bps, for example). Be sure that the power is off, and observe the static.

Figure 14
BIPC option switches and jumpers

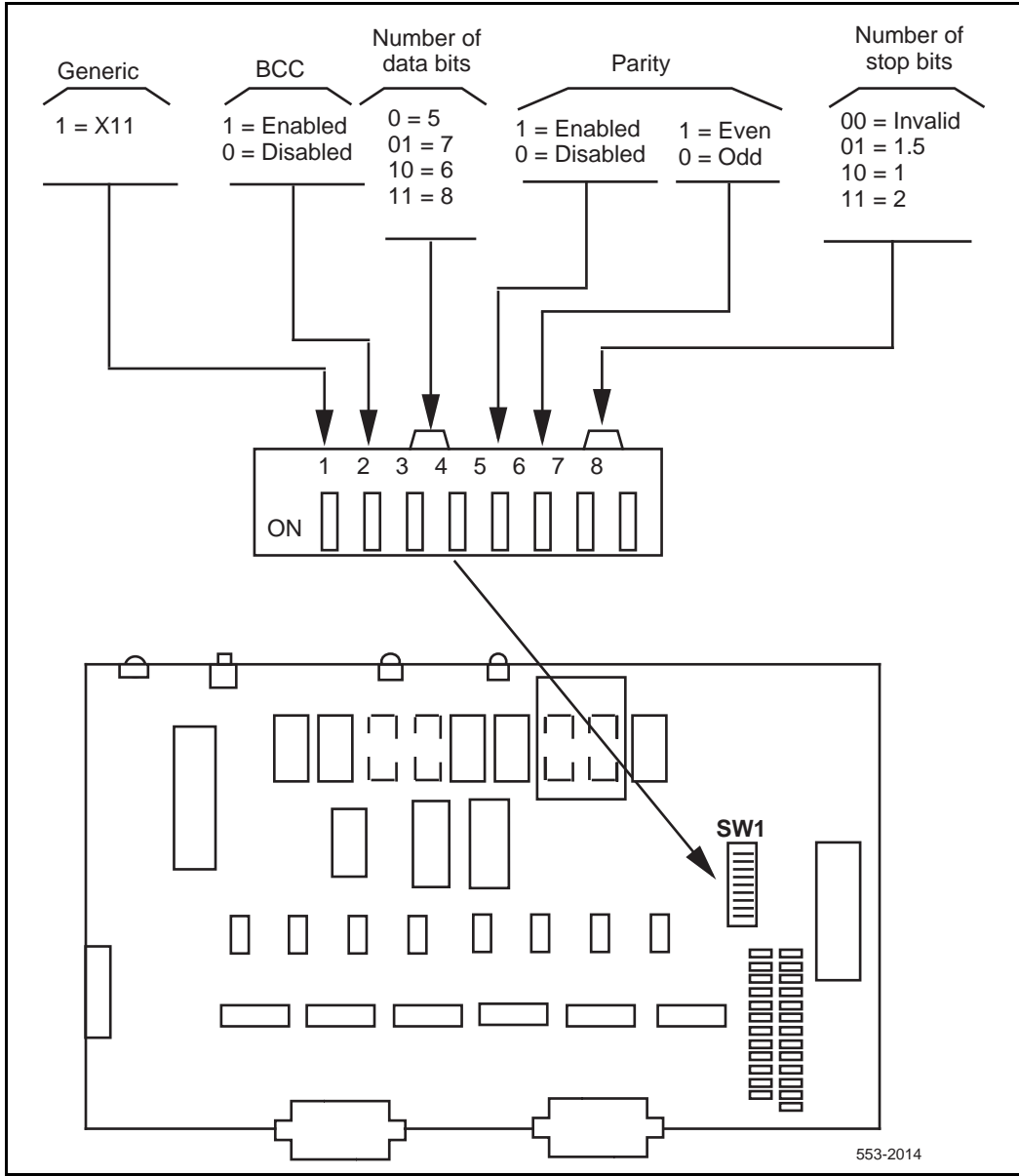

Cable connections

Connect data and power cables to the BIPC as detailed in Procedure 3 on page 36.

Operational checks

After the BIPC is installed, perform operational checks to verify that the BIPC is correctly transferring message data between the Meridian 1 and the PMS processor in both directions.

The actual operations for the test depend on the feature controlled by the PMS. In general, the procedure should check the following:

- Commands and data from the Meridian 1 are received correctly by the PMS processor.
- Commands and data from the PMS are received correctly by the Meridian 1.

Note: Use a datascopes to monitor data transfer if a problem is suspected.

Procedure 4 on page 38 illustrates a typical operational exercise using Room Status.

Summary

To install the BIPC, follow these steps. Where the step refers to another procedure, go to that procedure for complete instructions.

- 1 Unpack and inspect the equipment (Procedure 1).
- 2 Ensure that the required option settings are set on the BIPC. For PMS IBM Series 1 computer, or your In House System (IHS), refer to Procedure 2.
- 3 Clear the BIPC mounting location.
- 4 Install the BIPC in its operating location.
- 5 Verify, and set if necessary, the option selections on the SDI circuit pack.
- 6 Using RS-232-C cables, connect BIPC Port A to the SDI and BIPC Port B to the PMS data port (Procedure 3).
- 7 Connect power to the BIPC, and press the RESET button on the faceplate.
- 8 Check the installation by performing typical operations on the system (Procedure 4).

Note: To verify message transactions between the Meridian 1 and the PMS, it may be necessary to connect a datascoper into the circuit. Once the operation is verified, the datascoper can be removed.

Before unpacking your BIPC, ensure that the IBM series 1 is modified for PBX interface by LODGISTIX.

Procedure 1
Unpacking and inspection procedure

- 1 Open the shipping cartons and remove the equipment carefully. Inspect all items for external evidence of shipping damage. If there is noticeable damage, save the shipping cartons and notify Nortel Networks.
- 2 Remove the four screws securing the cover on the BIPC, and lift the cover from the unit.
- 3 Inspect the interior for components that may have loosened or been damaged in shipment (especially the 2716 PROM).
- 4 Report evidence of damage to Nortel Networks.

Note: If physical installation of the BIPC is to continue at this time, leave the cover off until you verify the option selectors and connect the power cabling. Otherwise, replace the cover on the unit.

Procedure 2
BIPC option verification

- 1 Remove the top cover of the BIPC (may already be removed in Procedure 1).
- 2 Check the data speeds for Ports A and B. Set Jumpers on options W2 and W1 to the positions marked with the required rates (Figure 14).
Note: Always use Port A for the BIPC/Meridian 1 interface and Port B for the BIPC/PMS interface.
- 3 Verify the options for Port B (selectors 3 to 8 on switch module SW1).
- 4 Verify selector 1 on switch module SW1 (ON for Meridian 1 systems).
- 5 Verify selector 2 on switch module SW1 (ON for BCC).
- 6 Replace the cover on the BIPC or proceed to Procedure 3.

Procedure 3
BIPC cable connection

- 1 Position the BIPC and the power supply at their operating locations (on top of the Meridian 1 cabinet, for example).
- 2 With the top cover removed from the BIPC, connect the power cable from the power supply to the power connector on the BIPC.
- 3 Replace the cover on the BIPC.
- 4 Connect one end of an RS-232-C cable to Port A on the BIPC, and the other to the applicable SDI connector on the SDI card.
- 5 Connect an RS-232-C cable (the maximum length is 50 ft) between the PMS data port and Port B on the BIPC. If the distance is greater than 50 ft, use a line driver or a short-haul modem.
- 6 Plug the power supply cord into a 110 V 60 Hz AC outlet.
- 7 The BIPC can now be placed in service, at any time.

The following procedure presents a typical exercise to verify the correct operation of a BIPC unit in a system set up for Room or Maid Status control. Before installing the BIPC, prepare the Meridian 1 for the interface. The preparation consists of the following steps.

- 1 The Room Status feature must be assigned to guest room directory numbers (DNs) (Controlled Class of Service Allowed [CCSA]).
- 2 Program a background terminal (BGD) capability on an SDI port. The Room Status feature can be administered from any terminal designated by a service change as a BGD. Use LD17 to configure the terminal with the following prompt-response sequence:
 - IOTB—YES
 - ADAN—NEW/CHG TTY xx
 - USER—BGD (Note 1)
 - PARM—YES
 - NDIS—150 (Note 2)

- 3 Use LD22 and the following prompt-response sequence to verify the system configuration update:
 - REQ—PRT
 - TYPE—CFN
- 4 Verify that the number of Number of Display Messages (NDIS) shown on the printout is 150 or more and that the only user listed on the background terminal is BGD.
- 5 Connect an ASCII terminal (or TTY) to the background port and set the following options. After you set the options, type OP <CR> to verify the settings.
 - A SE OP DI ON <CR>
SE OP DI ME OF <CR>
SE OP TE OF <CR>
SE OP DI DE OF <CR>
 - B SE OP PO (Port ID) OFF <CR>
SE OP PO (Port ID) ST ON <CR>
 - C SE OP CH ON <CR>
 - D SE OP TI DE OF <CR>
 - E SE OP TI RE OF <CR>
 - F SE OP TI DI ON <CR>
 - G SE OP SA ON <CR>
 - H SE OP CO OF <CR>
- 6 Use the steps in Procedure 4 to test the operation of the Room Status feature.

Note 1: Only BGD message type should be assigned to this port. If other users (MTC, SCH, BUG, etc.) are already assigned to the port, remove them before proceeding to the next step.

Note 2: The number of background display messages can range from 0 to 255. To prevent losing Room Status messages during heavy traffic periods, NDIS should be set to 150 or higher. If the system memory does not allow for such an accommodation, assign the maximum number allowed.

Procedure 4
Typical operational exercise (Part 1 of 2)

Step	Action	Verification
Room Status test		
1	Input: SE ST xxxx CH IN <CR> (Set status of room DN to Check In. xxxx is the room DN)	Try making an outgoing call from telephone xxxx. The system should permit this call type as well as room-to-room dialing.
	Input: SE ST xxxx CH OU <CR> (Set status of room DN to check out)	Try making an outgoing call from telephone xxxx. The system should not permit this call type. However, room-to-room dialing should be possible.
	Input: SE ST xxxx CH IN <CR> (Set status of room DN to check in)	Try making an outgoing call from telephone xxxx. The system should now permit this call type as well as room-to-room dialing.
2	Generate Room Status messages by dialing the proper digits from the guest room telephone.	Verify the status update, which should display automatically on the terminal.
3	If the above test is successful, use LD43 to perform a data dump.	

Procedure 4
Typical operational exercise (Part 2 of 2)

Step	Action	Verification
Meridian 1/BIPC/PMS link test		
Be sure that the BIPC is installed correctly and turned on before continuing.		
4	Press the RESET button to initialize the BIPC.	The diagnostic LED on Port A flashes momentarily.
5	Type the proper commands on a PMS terminal to initiate the database swap from PMS to Meridian 1.	The Port A and Port B LEDs flash to indicate activity on the ports.
6	After the database swap, check into a room by entering the proper commands on a PMS terminal.	The telephone in the room should be unrestricted room-to-room and outgoing calls can be made.
7	Check out of the room by entering the commands on a PMS terminal.	The telephone in the room should be restricted except for room-to-room calling.
8	Repeat steps 6 and 7 for other rooms.	Verify the responses.
9	Generate Maid Status messages by dialing the proper digits from a room telephone.	Verify the cleaning status update on a PMS terminal.

Note: If the above sampling of commands and responses (or a similar sampling) is processed. You may have to connect a datascoper into the circuit to verify the operations. Remove it after the tests are completed.

Operating procedures

Placing in service

Follow these steps to place the BIPC in service:

- 1 Verify that the BIPC is installed correctly, that Meridian 1 data fill is completed, and that all data and power cables are connected securely.
- 2 Plug in the power supply. (The red power indicator lights.)
- 3 Press the BIPC RESET button. This sends a <CR> to the Meridian 1.

The BIPC is now ready. No further adjustment is required for normal operation.

Restoring service

If, for any reason, service through the BIPC is interrupted, restart the BIPC by pressing the RESET switch. However, if the BIPC itself is faulty, it may be necessary to replace the unit. Additionally, check the SDI port to be sure that it is set and operating properly.

Repair procedure

The BIPC has no field replaceable parts other than the power supply. Replace a faulty BIPC with a working unit to ensure continued operation. To do so, follow the replacement procedures for defective Meridian 1 units.

Ordering information

BIPC equipment can be ordered from Nortel Networks by quoting the applicable ordering codes and quantities required as follows:

Equipment	Ordering Code	Quantity Required
BIPC	A0297075	One per PMS/Meridian 1 Interface (includes one power supply)
Power Supply	A0297998	One per BIPC

Specifications

Mechanical

BIPC mechanical specifications and associated hardware appear as follows:

BIPC (A0297075)

Size	Width: 14 in. (356 mm) Height: 2.5 in. (64 mm) Depth: 7 in. (178 mm)
Weight	2.5 lbs (1.6 kg)
Enclosure	all metal

Power Supply (A0297998)

Size	Length: 4.75 in. (121 mm) Width: 2.75 in. (70 mm) Height: 2.25 in. (57 mm)
Cables	Input: 6 ft (1.8 m), 3-wire, fitted with a UL/CSA approved 3-pin plug Output: 7 ft (2.1 m), 5-wire (18 AWG) with strain relief

Electrical

BIPC Electrical specifications and associated equipment appears as follows:

BIPC (A0297075)

Power requirement	+ 5 V dc, 800 mA
	+ 12 V dc, 100 mA
	-12 V dc, 100 mA

Power Supply (A0297998)

Input power	105 to 129 V ac, 57 to 60 Hz
Output power	+ 5 V dc $\pm 5\%$ at 1.0 A
	+ 12 V dc $\pm 5\%$ at 0.2 A
	-12 V dc $\pm 5\%$ at 0.2 A
Ripple and noise	δ 10 mV ms on all outputs
Regulation	δ $\pm 5\%$ on all outputs
UL and CSA approved	

RS-232-C interface

The following is a summary of the mechanical and electrical characteristics of the interface between the BIPC and an SDI port:

- Electrical interface: Compatible with EIA Standard RS-232-C
- Operating mode: Full duplex, asynchronous
- Signal logic levels:
 - Space or ON = more positive than + 3 V (binary 0)
 - Mark or OFF = more negative than -3 V (binary 1)
- ASCII character set
- No parity (parity disabled)
- Word framing: 10 bits consisting of the following:
 - 1 START bit
 - 8 DATA bits (Bit 8 is always tied to high)
 - 1 STOP bit

- No message control (logical) protocol (that is, no ENQ, ACK, and so on)
- No data record frame characters
- The SDI port connector is female
- The SDI data port addresses are 00 to 15
- The prompt character is a period (hex 2E)
- The character sequence indicating that a Meridian 1 initiated data stream is as follows:

0DH 0AH 00H 00H 00H 00H 00H 00H (CR LF nul nul nul nul nul)

The following is a summary of the mechanical and electrical characteristics of the interface between the BIPC and a PMS port:

- Electrical interface: Compatible with EIA Standard RS-232-C
- Operating mode: Full duplex, asynchronous
- Signal logic levels:
 - Space or ON = more positive than + 3 V (high)
 - Mark or OFF = more negative than -3 V (low)
- Signal form: Compatible with EIA Standard RS404
- Data rate: 110, 134, 150, 300, 600, 1200, 1800, 2400, 3600, 4800, 7200, or 9600, selectable
- Parity: Odd or even (or no parity), selectable
- Word framing:
 - 1 START bit
 - 5, 6, 7, or 8 DATA bits (selectable)
 - 1 PARITY bit
 - 1, 1-1/2, or 2 STOP bits (selectable)
- Maximum message text: 100 bytes
- The PMS port connector is female

List of terms

ACK

Acknowledge or affirmative response from the receiver to the sender. If BCC is used, ACK also indicates BCC check matches.

BCC

Block Character Checks.

BIPC

Buffer Interface/Protocol Converter.

DCE

Data Communication Equipment. The interfacing equipment that couples from a data terminal into a transmission circuit or channel, and from a transmission circuit or channel into a data terminal.

DTE

Data Terminating Equipment. The functional unit of a data station that serves as a data source or data sink and provides for the data communication control function to be performed in accordance with link protocol.

DTR

Data Terminal Ready.

NAK

Not Acknowledged or a negative response from the receiver to the sender. For example, not ready to receive a message or a block of data received with errors, requires retransmission.

PMS

Property Management System.

SDI

Serial Data Interface.

Index

A

ACK/NAK responses

- BIPC initialization, 18
- message priorities, 21
- message protocol, 21

B

baud rates

- RS-232-C interface, 12
- setting, 31

BCC (Block Character Checks)

- as error control function, 15
- described, 20
- mismatch, 26
- setting on/off, 20, 32

BIPC (Buffer Interface/Protocol Converter)

- communication channel connections, 23
- description, 11
- installation block diagram, 8
- installing, 29
- interface circuits/protocols, 17
- operating procedures, 41
- ordering equipment, 43
- overview, 7
- setting options, 31
- specifications, 45

BIPC/ Meridian 1 link, 20

BIPC/PMS link, 20

buffer, size of data, 12

C

cables

- connecting, 33, 36
- maximum length, 29
- power, 12, 31, 45
- See also* RS-232-C cables/connectors

capabilities, BIPC, 17

CCITT V.24 standard, 18

characters. *See* BCC (Block Character Checks);
control characters; special character
definitions

communication channel connections, 23

component layout (circuit card), 13

connectors

- external, 12
- pin assignments, 19
- See also* RS-232-C cables/connectors

control characters, 22

D

data links, logical control options for, 18

data rates. *See* baud rates

dimensions, physical, 11, 45

documentation, reference, 9

DTR (Data Terminal Ready) signal
continuously-on option, 20

E

electrical specifications, 46

error control functions, 15

errors, BCC mismatch, 26

G

glossary, 49

H

handshaking. *See* ACK/NAK responses

I

indicators, front panel, 11
initialization, 12, 18
inspecting BIPC, 29
installing BIPC, 29
interface circuits, 17

J

jumpers
 changing data link control options, 18
 setting data rates, 31
 stop bit settings, 32

L

Link Control protocols
 overview, 17, 18
LODGISTIX, preinstallation coordination with, 7
logic levels
 PMS port, 47
 SDI port, 46

M

Maid Status feature, verifying operation of, 36, 39
mechanical specifications, 45
Meridian 1
 checking command/data transfer, 33, 39
 RS-232-C port baud rate, 12
message control protocols, 17, 21
message envelopes, 20
message handling protocols, 15
message priorities, 21
messages
 invalid format, 25
 multiple, 28
 sample transactions, 23
microprocessor, Z80, 12
mounting location, BIPC, 29

N

NAK. *See* ACK/NAK responses

O

operating procedures, 41
operational checks
 Meridian 1/BIPC/PMS link test, 39
 overview, 33
 Room/Maid Status feature, 36
option settings
 described, 29
 switches/jumpers controlling, 32
 verifying, 35
ordering BIPC equipment, 43

P

parity bits/checks
 as error control function, 15
 option switch settings, 32
 PMS port, 12, 47
 SDI port, 46
pin assignments, RS-232-C interface
 SDI through IHS, 19
PMS (Property Management System)
 checking command/data transfer, 33, 39
 interfacing to switch, 7
 RS-232-C port baud rate, 12
Port A (BIPC to Meridian 1)
 electrical/mechanical specifications, 46
 word format, 20
Port B (BIPC to PMS)
 electrical/mechanical specifications, 47
 word format, 20
power supply
 cables/connectors, 14
 described, 11
 electrical specifications, 46
 mechanical specifications, 45
 mounting location, 29
protocol conversion, 15
protocol requirements, 17

R

reference documentation, 9
repair procedure, BIPC, 41
resetting BIPC, 12, 18, 41
restoring service, 41
Room Status feature, verifying operation of, 36, 38
RS-232-C cables/connectors
 external locations, 11
 pin wiring, 14
RS-232-C interface
 baud rates, 12
 BIPC interchange circuits, 18
 described, 12
 electrical/mechanical specifications, 46

S

SDI (Serial Data Interface) port
 pin assignments, 19
 setting address/speed switches, 30
signal logic levels. *See* logic levels
special character definitions, 22
specifications, 45
stop bits, setting number of, 32

T

test equipment, recommended, 8

tests, operational, 33

U

unpacking BIPC, 29, 35

V

V.24. *See* CCITT V.24 standard

W

word format, 12
 diagram, 21
 jumper settings, 32
 Port A/B settings, 20
word framing
 PMS port, 47
 SDI port, 46

X

X11 release 15 and later, 8

Z

Z80 microprocessor, 12

Meridian 1

Buffer Interface/Protocol Converter

Description

Copyright ©1989–2000 Nortel Networks

All Rights Reserved

Information is subject to change without notice. Nortel Networks reserves the right to make changes in design or components as progress in engineering and manufacturing may warrant. This equipment has been tested and found to comply with the limits for a Class A digital device pursuant to Part 15 of the FCC rules, and the radio interference regulations of Industry Canada. These limits are designed to provide reasonable protection against harmful interference when the equipment is operated in a commercial environment. This equipment generates, uses and can radiate radio frequency energy, and if not installed and used in accordance with the instruction manual, may cause harmful interference to radio communications. Operation of this equipment in a residential area is likely to cause harmful interference in which case the user will be required to correct the interference at their own expense.

SL-1 and Meridian 1 are trademarks of Nortel Networks.

Publication number: 553-2801-100

Document release: Standard 5.00

Date: April 2000

Printed in Canada



How the world shares ideas.