

---

Meridian 1

# Coordinated Dialing Plan

## Description

---

Document Number: 553-2751-102

Document Release: Standard 5.00

Date: April 2000

---

Copyright ©1982–2000 Nortel Networks  
All Rights Reserved

Printed in Canada

Information is subject to change without notice. Nortel Networks reserves the right to make changes in design or components as progress in engineering and manufacturing may warrant. This equipment has been tested and found to comply with the limits for a Class A digital device pursuant to Part 15 of the FCC rules, and the radio interference regulations of the Canadian Department of Communications. These limits are designed to provide reasonable protection against harmful interference when the equipment is operated in a commercial environment. This equipment generates, uses and can radiate radio frequency energy, and if not installed and used in accordance with the instruction manual, may cause harmful interference to radio communications. Operation of this equipment in a residential area is likely to cause harmful interference in which case the user will be required to correct the interference at this own expense.

SL-1 and Meridian 1 are trademarks of Nortel Networks.



---

## Revision history

---

**April 2000**

Standard 5.00. This is a global document and is up-issued for X11 Release 25.0x.

**July 1995**

Standard 4.00 introduces changes caused by interaction with the Collect Call Blocking in Release 21.

**July 1994**

Standard 3.00 introduces the following X11 Release 20 features and capabilities:

- Interchangeable Numbering Plan Area codes, and
- Federal Communications Commission Equal Access Carrier Access Code Expansion.

**December 1991**

This document is reissued to include technical content updates.

**December 1989**

Standard 1.00. Reissued for compliance with Nortel Networks standard 164.0 and to include updates for X11 Release 15.



---

# Contents

---

<b>Feature description</b> .....	<b>7</b>
Reference list .....	7
Steering codes .....	8
Flexible Numbering Plan .....	9
Conventional Switch Access .....	11
Network Class of Service .....	12
Compatibility with ETN switches .....	13
Assumptions .....	14
Facility Restriction Level .....	14
Routing .....	14
Digit manipulation .....	15
Time of day schedules .....	15
Queuing .....	16
CDP traffic measurements .....	16
Feature interactions .....	16
Federal Communication Commission Equal Access Carrier	
Access Code Expansion impact .....	20
Dialing Plan considerations .....	21
Carrier Access Codes dialing sequences with special characters ..	24
Configuring Equal Access within a Network .....	24



---

# Feature description

---

## Reference list

The following are the references in this section:

- *Traffic measurement formats and output (553-2001-450)*
- *Basic and Network Alternate Route Selection description (553-2751-100)*
- *Flexible Numbering Plan description, operation, and administration (553-2751-105)*
- *ISDN Primary Rate Interface description and administration (553-2901-301)*
- *X11 features and services (553-3001-306)*
- *X11 Administration (553-3001-311)*

The Coordinated Dialing Plan (CDP) feature enables a customer with a number of local Meridian 1s to coordinate the dialing plan for stations at these switches. When implemented, the Coordinated Dialing Plan (CDP) feature enables a station at one switch to call a station at another switch within the CDP group by dialing a unique 3 to 7 digit number, without access codes and associated pauses for dial tone. When equipped with the Directory Expansion (DNXP) package, this number can have up to 10 digits.

The CDP software provides the translation and digit manipulation capability required to implement the Coordinated Dialing Plan (CDP). Calls dialed within the CDP format can be terminated locally after digit translation or digit deletion. Alternatively, calls can be routed to a remote switch in the CDP group following digit translation, route selection, and digit deletion or insertion. Figure 1 illustrates how a coordinated dialing plan would be implemented at two customer locations.

## Steering codes

In Figure 1, users at Location D can call stations at Location E by dialing 43XXX or 52XXX. Similarly, users at Location E can call stations at Location D by dialing 2XXXX or 3XXXX. If a user at Location D dials 43XXX or 52XXX to reach a station at Location E, Location D uses the digits “43” or “52” as a Distant Steering Code (DSC) to select the trunk group to Location E. Similarly, if a user at Location E dials 2XXXX or 3XXXX to reach a station at Location D, Location E uses the digit 2 or 3 as a Distant Steering Code (DSC).

**Figure 1**  
**Example of a Coordinated Dialing Plan**

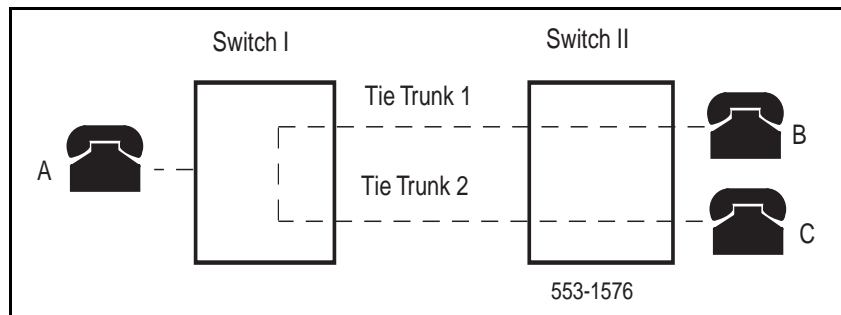

The same format is used for calling local stations. For example, users at Location E dial 43XXX or 52XXX to reach local stations at Location E. In this case, the Meridian 1 interprets the digits 43 or 52 as a Local Steering Code (LSC) and deletes them from the dialed number in order to terminate the call locally.

The maximum number of leading digits that can be deleted from a local steering code is 4. However, if the DNXP package (150) is equipped, these steering codes can be up to 7 digits long and therefore up to 7 digits can be deleted from the Local Steering Code SPRE (LSC).

If the Meridian 1 at Location E is arranged to provide centralized access to the public exchange network, the digit 9 at Location E is a Trunk access code for public exchange access. At Location D, the digit 9 is a Trunk Steering Code (TSC) which uses digit manipulation to insert the required digits to route the call through Location E to the public exchange network.



The CDP feature supports up to 5000 steering codes (with Release 13 and later, the CDP feature can support up to 10,000 steering codes). Steering codes can be composed of one, two, three or four digits. At each switch in the CDP group, the steering codes must be distinct from any other assigned DN codes. As Figure 1 shows, 0 is reserved as the attendant access code; 1 is reserved as the Special Service Prefix (SPRE); 7 is reserved as a Meridian 1 trunk access code; 8 is reserved as a Basic Alternate Route Selection / Network Alternate Route Selection (BARS/NARS) access code; and 9 is reserved as the public exchange network access code. This means there are five digits remaining that can be used as the leading digits of steering codes — 2, 3, 4, 5, and 6. Switch D chooses 2 and 3; switch E uses 4 and 5.

A CDP Directory Number (DN) consists of an internal DN prefixed with the appropriate steering code. The CDP DN is allowed up to 7 digits maximum; but, if the DNXP package is equipped, this number can be increased to 10 digits maximum. A typical CDP configuration is shown in Figure 2.

## Flexible Numbering Plan

Flexible Numbering Plan (FNP) package 160 was introduced to the International marketplace as part of the X11 with Supplementary Features Group E (Phase 5) release.

FNP accommodates Global Numbering Plan Requirements by modifying the Electronic Switched Network (ESN) dialing plan. The dialing plans are divided into two areas:

- On-net dialing — which deals with all the possible dialing situations required when dialing to a station located within the Local (private) Network, and
- Off-net dialing — which deals with all the possible dialing situations required when dialing to a station that is not part of the Local Network (typically the Public Numbering Plan).

FNP was enhanced in the Group F (Phase 6Biv) release to include the ability of inhibiting the time out handling process for ESN Basic Alternate Route Selection (BARS) and Network Alternate Route Selection (NARS) Special Numbers (SPN) and Coordinated Dialing Plan (CDP) Trunk Steering Codes (TSC). The enhancement ensures that all digits are collected prior to seizing a trunk. This enhancement meets Chinese requirements.

**Figure 2**  
**A typical CDP configuration**

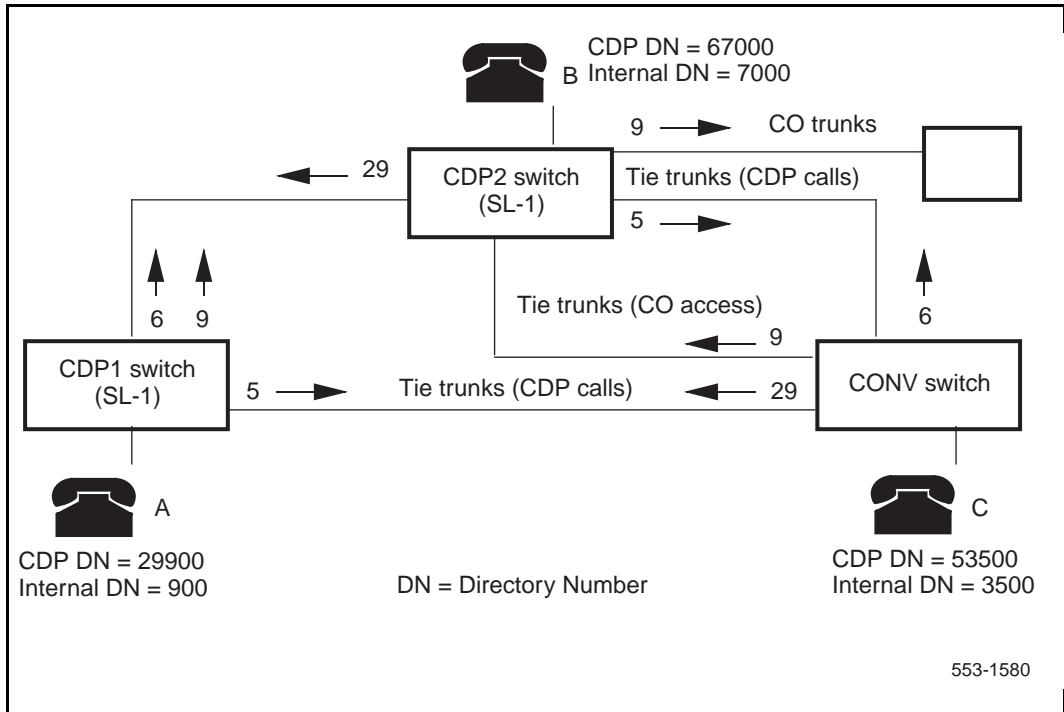

Network Alternate Route Selection (NARS) package 58 is a prerequisite for FNP.

With X11 release 20, FNP was introduced to the Global marketplace.

FNP interacts with both NARS and Coordinated Dialing Plan (CDP) to introduce:

- Universal Numbering Plan (UNP),
- Transferable Directory Numbers (TNDN),
- Group Dialing Plan (GDP),
- Arbitrary length DNs on a node, and
- Free Special Number Screening (FSNS).

For further information about FNP refer to *Flexible Numbering Plan description, operation, and administration (553-2751-105)*.

## Conventional Switch Access

If a conventional (CONV) switch without the CDP software is integrated as part of a CDP group (Figure 2), the steering codes defined at a CDP switch to access the conventional switch can be inserted or deleted by the CDP switch. The steering codes are inserted if the conventional switch is identified by more than one steering code; they are deleted if all the station numbers at the conventional switch begin with the same steering code.

Calls to a CDP switch from the conventional switch are made by dialing the desired CDP DN. The CONV switch uses the digit 6 as a trunk access code for the tie trunk route to switch CDP2. After tie trunk seizure, the CONV switch outputs the remaining digits (7000) to CDP2. At CDP2, the digit 6 is inserted on the incoming tie trunk from the CONV switch, prior to receipt of any digits from the CONV switch, and the call is completed to station E.

Local calls at the CONV switch are made by dialing only the internal DN (3500), rather than the CDP DN (53500), unless the CONV switch can be arranged to absorb the digit 5 or is based on a 5-digit numbering plan.

As shown in Figure 2, switch CDP2 is arranged to provide centralized access to the public exchange network. For users at the CONV switch to access this capability, a separate tie trunk route must be provided to switch CDP2. This is because switch CDP2 is arranged to insert the digit “6” on the incoming tie trunk route from the CONV switch used for CDP calls. For public exchange network calls, the digit 9 must be inserted on the incoming tie trunk route from the CONV switch. Similarly, if users at the CONV switch are to be allowed access to the ESN capabilities (BARS/NARS) at switch CDP2, another tie trunk route must be provided for this purpose.

## Network Class of Service

Network Class of Service (NCOS) is an integral part of the CDP feature. NCOS provides the means to control the following:

- which trunk routes are eligible to be accessed for completion of a CDP call,
- whether or not queuing is offered to the call originator, and
- whether or not the originator of a CDP call receives an Expensive Route Warning Tone (ERWT) when an expensive trunk route is selected to complete the call.

A CDP equipped switch can accommodate four NCOS groups (0-3), each group with different route-access characteristics. See Table 1

**Note 1:** Numbers preceding \*\* apply to X11 release 15 and greater. Numbers with \* apply to X11 releases 13 and 14.

**Note 2:** The BARS/NARS features are described in detail in the *Basic and Network Alternate Route Selection description (553-2751-100)*.

**Note 3:** If New Flexible Code Restriction (NFCR) is equipped in conjunction with CDP, the number of available NCOS groups is 8; with Release 13 and later, this number is increased to 100.

**Note 4:** Values in parenthesis () are for releases prior to X11 release 13. Values in brackets [] apply if the Flexible Numbering Plan (FNP) package (160) is equipped.

BARS/NARS feature is also equipped. Once each NCOS group is defined through service change; then line, trunk, and attendant groups are assigned to the NCOS group which best serves their requirements. The NCOS group to which each line, trunk or attendant group is assigned is independent of the regular Class Of Service assigned to them.

With Release 13 and later, a CDP equipped switch can accommodate 100 NCOS groups (0–99) whether it is equipped with BARS/NARS, or the New Flexible Code Restriction (NFCR).

**Table 1**  
**Summary of CDP parameters**

Parameter	CDP stand-alone	CDP with BARS	CDP with NARS
Network Class of Service Groups (Note 3)	0-3 (0-99)	0-7 (0-99)	0-15 (0-99)
Facility Restriction Levels	0-7	0-7	0-7
Time-of-Day schedules	0-1	0-7	0-7
Digit Manipulation tables	1-31	1-255	1-255 [1-999]
Route lists	0-31 0-127	0-127	0-255 [0-999]
Route list entries	0-2 0-(6)	0-7 0-31* 0-63**	0-7 0-31* 0-63**
Supplemental Digit Restriction tables release 4 and earlier	—	0-31	0-255
release 5 and later	—	0-255	0-511
Steering codes	5000 10000	5000 10000	5000 10000 [32000]

## Compatibility with ETN switches

The Traveling Class Of Service (TCOS) is equivalent to the Traveling Class Mark (TCM) used at Electronic Tandem Network (ETN) switches. It provides a mechanism through which the system can control route access (FRL) and off-hook queuing (OHQ) eligibility for calls placed to or through another Node, or ESN Main, and enables the switch to interface with ETN switches.

When a Distant Steering Code (DSC) call is made from an Electronically Switched Network (ESN) Node to an ETN switch, the dialed digits, together with the TCOS number (0–7), are sent to the connected ETN switch. Similarly, when a DSC call is made from an ETN switch to an ESN Node, the dialed digits, together with the TCM number (0–7), are sent to the connected ESN Node. On a tandem connection to the ESN Node interprets the received TCM as a TCOS number. The received TCM replaces the FRL of the NCOS assigned to the incoming trunk group from the ETN switch.

## Assumptions

The assumptions are as follows:

- Only DSC, not Trunk Steering Code (TSC), calls are supported with this capability.
- When a DSC call is terminated on a switch as a Local Steering Code (LSC) call, the transmitted TCOS/TCM number from the connected ETN switch is not collected and saved by the terminating switch.

## Facility Restriction Level

Included as part of each NCOS group is a Facility Restriction Level (FRL) number which ranges from 0 (low-privilege) to 7 (high-privilege). The FRL is used by the CDP software to determine the alternate route selection choices available for CDP call attempts by users within an NCOS group.

### Example

A station user assigned in an NCOS group having an FRL of 3 would be allowed access only to alternate route selection choices assigned an FRL of 3 or less; access to trunks with an FRL greater than 3 would be denied.

## Routing

Thirty-two route lists (0–31) can be defined at a switch equipped with CDP. See Table 1 for other parameters if CDP is equipped with Basic Alternate Route Selection or Network Alternate Route Selection. A route list is used to define the alternate route choices for CDP calls to a particular destination. Route choices in a route list are called route list entries. There can be up to three (0–2) route list entries associated with each route list, or seven (0–6) in Release 13 and later.

Route lists are associated with each Distant Steering Code (DSC) and Trunk Steering Code (TSC) that can be dialed at a CDP switch. Local Steering Codes (LSC) are not associated with route lists. Each code is defined to the CDP software, together with the number of the route list that must be accessed for call completion to the destination indicated by the steering code. The entries in the specified route list are then searched sequentially for an available and eligible trunk route.

Release 15 and later software allows CDP to route Direct Inward Dialed (DID) calls over CO and WATS trunks using a Distant Steering Code (DSC). The feature is controlled by an option defined in the Customer Data Block (LD 15) found in the *X11 Administration (553-3001-311)*. This enhancement applies to CO, WATS, DTI and ISDN type trunks.

## Digit manipulation

Route list entries can be associated with digit manipulation tables. There can be 32 (0–31) digit manipulation tables defined at a CDP switch. See Table 1 if BARS/NARS is also equipped. Every digit manipulation table except 0 can be defined to delete up to 15 digits from a dialed CDP number, and to insert up to 24 leading digits, including the asterisk. Digit manipulation table 0 is used as an indication to the CDP software that no digit manipulation is required.

## Time of day schedules

Two (0–1) time of day (TOD) schedules can be defined at a CDP switch. See Table 1 if BARS/NARS is also equipped. Each route list entry is associated with a TOD schedule. When a route list entry is selected for a CDP call, the CDP software compares the current time with the TOD schedule assigned to the route list entry. If the current time is within the schedule, the route list entry is used for the call. If the current time is not in the schedule or, if the TOD schedule is turned OFF, the route list entry is not used for the call. Each TOD schedule can be turned ON or OFF by the customer through service change.

## Queuing

Queuing against local stations is provided by the standard Ring Again (RGA) feature. Please refer to the *X11 features and services (553-3001-306)*. For calls directed to a remote CDP switch, Ring Again can be applied if all local outgoing trunk routes to the remote CDP switch are busy or blocked. Ring Again cannot be applied against busy or blocked telephones, or consoles at the remote CDP switch. Trunks can only be rung again if CCBQ or CBQM are equipped. Intercept treatment is not provided until the full CDP number (or trunk steering code) is dialed.

For local and network queuing descriptions, refer to *Basic and Network Alternate Route Selection description (553-2751-100)*. For ESN operations in an ISDN environment, consult the *ISDN Primary Rate Interface description and administration (553-2901-301)*.

## CDP traffic measurements

Traffic measurement data related to CDP feature usage is available at an Meridian 1 equipped with the Network Traffic (NTRF) feature. The user should refer to *Traffic measurement formats and output (553-2001-450)*.

## Feature interactions

**AIOD and ANI** Calls made to the public exchange network when the Automatic Identification of Outward Dialing (AIOD) or Automatic Number Identification (ANI) feature is equipped will have either the internal DN recorded if the call originates at the CDP switch interfacing to the public network or the trunk access code if the call originates at another CDP switch.

**Attendant Features** If a user at a local CDP switch calls the local attendant, the local user's internal DN (not the full CDP DN) is displayed. If a user at a CDP switch calls an attendant at another CDP switch, the trunk access code and member number of the incoming trunk are displayed.



The following attendant features are supported at a local CDP switch but are not supported between CDP switches:

- automatic timed recall,
- barge-in, busy verify,
- camp-on, and
- interposition calling.

**BARS/NARS** The CDP feature can be implemented at a switch equipped with the BARS/NARS software features. If such is the case, the following considerations apply.

- Steering codes for CDP calls must be distinct from the assigned BARS/NARS access codes.
- CDP numbers can be integrated with the NARS Uniform Dialing Plan (UDP). For example, a five-digit CDP number can be the same as the last five digits of a seven-digit UDP number.
- BARS/NARS route lists, digit manipulation tables and TOD schedules can be shared by CDP calls.
- Users eligible for the Off-Hook Queuing (OHQ) and Call-Back Queuing (CBQ) features can use them when placing CDP calls.
- Free Calling Area Screening (FCAS) does not apply to CDP calls.
- Routing Control can be applied to CDP calls. Please refer to *Basic and Network Alternate Route Selection description (553-2751-100)*.

**Call Modification** Call modification (call transfer, call forward, conference) is allowed for CDP calls. When using these features, the user dials within the CDP format.

**Call Detail Recording** The local internal DN (not the complete CDP DN) is recorded in the normal CDR manner. The full CDP DN is shown in the dialed number field. The maximum internal DN length remains at four digits.

**Code Restriction** Code restriction is applied to calls made only from stations with a Toll Denied (TLD) class of service. Code Restriction or New Flexible Code Restriction (NFCR) can be applied on a trunk route basis to public exchange network trunk calls.

**Collect Call Blocking** New classes of service and prompts are introduced to inhibit specific users from receiving collect DID and CO calls. When tandem calls are made, the source node determines the CCB treatment for all outgoing calls. For CDP routed calls, the CCBA prompt associated with the DSC or TSC is checked. For non-CDP routed calls (UDP, Access code, RAN, or Music Route), the CCBA prompt in the route data block is checked. The Meridian 1 will provide the CCB answer signal to the CO for all incoming DID and CO calls from routes with CCB enabled that are answered by CCB users. The CCB answer signal can only be sent in cases where answer supervision is provided by the Meridian 1. For CDP routed calls this will happen regardless of the class of service of the far end. If the call is collect the CO will disconnect it. The decision to send the CCB answer signal is made on the source node (the node closest to the CO) and is based on the CCB user hierarchy shown in Table 2 below. In either case, the DID/CO route must have Collect Call Blocking enabled.

**Table 2**

<b>CCB User Hierarchy</b>	
<b>1</b>	The setting of incoming routes CCB prompt.
<b>2</b>	The source (first) ACD queue's setting of the CCBA prompt.
<b>3</b>	The CCB option in the customer data block for NAS routing.
<b>4</b>	The CDP steering code's setting of the CCBA prompt.
<b>5</b>	The outgoing route's setting of the CCBA prompt.
<b>6</b>	The COS of the terminating set. If attendant answers the call, then the CCBA option in CDB.
<b>7</b>	The DISA data block's setting of CCBA

**Common Control Switching Arrangement** A CDP number can be part of a CCSA dialing plan. Digit absorption and manipulation for CCSA calls is handled as usual by the switch. A CCSA call can terminate at a switch in a CDP group other than the switch which hosts the CCSA network. This operation is transparent to the originator of the CCSA call.

**COS/TGAR Treatment** For CDP calls, all Class of Service (COS) treatment remains the same as standard treatment with the exception of conditionally toll-denied (CTD) and conditionally unrestricted (CUN) COS, which are treated as unrestricted (UNR). Users with an FR2 class of service can originate local CDP calls but cannot originate CDP calls to distant switches. Trunk Group Access Restrictions (TGAR) are ignored for the purpose of routing CDP calls.

**Direct Inward Dialing** Because a CDP DN can be up to 10 digits long, the capability of inserting up to 8 leading digits on a DID trunk is supported.

**Display** The following lists how a digit display set handles CDP calls.

- **Outgoing CDP Call** — The complete dialed CDP DN is displayed at the originating set.
- **Incoming CDP Call** — The trunk access code and member number of the incoming trunk route is displayed.
- **Internal CDP Call** — At the originating set, the complete dialed CDP DN is displayed. If the call hunts or is picked up by another station, the internal DN of the answering station is displayed. At the terminating set, the internal DN of the originating set is displayed.
- **Network Call Transfer** — NXFER interacts with CDP calls in the same manner as ESN network calls. See *Basic and Network Alternate Route Selection description (553-2751-100)* for a full description of NXFER.

**End-to-End Signaling** End-to-End signaling is allowed for CDP calls.

**Hunting** Hunting across different switches in a CDP group is not supported. Standard Hunting can be applied to local CDP calls.

**Interchangeable Numbering Plan Area codes** Due to the fact that Interchangeable Numbering Plan Area (NPA) codes plan removes the requirement of the second digit in an NPA being zero (0) or one (1) the Toll Denied (TLD) class of service is no longer a reliable method of toll denying sets. To reliably toll deny sets the Code Restriction or New Flexible Code Restriction (NFCR) feature must be used.

**Message Center** The message center capability is not supported across CDP switches. However, it operates as normal locally.

## Federal Communication Commission Equal Access Carrier Access Code Expansion impact

In May 1991, the Federal Communications Commission (FCC) mandated that Call Aggregators (CA) allow customers *Equal Access* to interexchange carriers. This capability is available with X11 release 17 and later. This allows callers to use interexchange carriers regardless of the CA's prescribed carrier. As a concession to CA's the FCC has allowed the optional restriction of direct dialed Equal Access toll calls.

Any call preceded by a Carrier Access Code (CAC) is considered to be an Equal Access call. The CAC consists of an Equal Access identifier and a Carrier Identification Code (CIC) which identifies the desired interexchange carrier for a given call. The FCC Equal Access CAC Expansion allows the Equal Access identifier to be expanded from two to three digits, and the CIC to be expanded from three to four digits. Table 3 gives examples of both the original and expanded CAC formats:

**Table 3**  
**Original and expanded CAC formats**

CAC formats	Equal Access Identifier	Carrier Identification Code
Original	10	XXX
Expanded	101	XXXX

The expanded format is effective as of the first quarter 1995, both formats, original and expanded, will be allowed to coexist for approximately 18 months at which time the original format will be discontinued (fourth quarter 1996).

Along with the introduction of the expanded CAC the FCC Equal Access CAC Expansion feature also eliminates the Selective Carrier Restriction method capabilities, while retaining the General Carrier Restriction capabilities. This results in a single restriction method which will be referred to as Equal Access toll call restriction.

## Dialing Plan considerations

To assist Network Dial Plan Administrators in planning for the CAC expansion the following tables show the formats supported and the time frames they are supported in:

**Table 4**  
**CAC formats supported until December 31, 1994**

<p><b>Operator-assisted dialing to North American and International locations:</b></p> <p>10CIC + 0</p> <p>10CIC + 0 + NPA + NXX + XXXX</p> <p>10CIC + 0 + NXX + XXXX</p> <p>10CIC + 0 + SAC + NXX + XXXX</p> <p>10CIC + 01 + CC + NN</p>
<p><b>Direct Distance Dial (DDD) dialing to North American and International locations:</b></p> <p>10CIC + 1 + NPA + NXX + XXXX</p> <p>10CIC + 1 + NXX + XXXX</p> <p>10CIC + 011 + CC + NN</p>
<p>Where CIC may be any of the following, 000 to 099, 110 to 149, and 170 to 199. 100 to 109 and 150 to 169 are reserved.</p>

**Table 5**  
**CAC formats supported from January 1, 1995 to May 31, 1996**

**Operator-assisted dialing to North American and International locations:**

10CIC + 0  
10CIC + 0 + NPA + NXX + XXXX  
10CIC + 0 + NXX + XXXX  
10CIC + 0 + SAC + NXX + XXXX  
10CIC + 01 + CC + NN  
101ECIC + 0  
101ECIC + 0 + NPA + NXX + XXXX  
101ECIC + 0 + NXX + XXXX  
101ECIC + 0 + SAC + NXX + XXXX  
101ECIC + 01 + CC + NN

**Direct Distance Dial (DDD) dialing to North American and International locations:**

10CIC + 1 + NPA + NXX + XXXX  
10CIC + 1 + NXX + XXXX  
10CIC + 011 + CC + NN  
101ECIC + 1 + NPA + NXX + XXXX  
101ECIC + 1 + NXX + XXXX  
101ECIC + 011 + CC + NN

Where CIC may be any of the following, 000 to 099, 110 to 149, and 170 to 199 and ECIC may be 5000 to 6999.

**Table 6**  
**CAC formats supported from June 1, 1996 onward**

<b>Operator-assisted dialing to North American and International locations:</b>	
	101XXXX + 0
	101XXXX + 0 + NPA + NXX + XXXX
	101XXXX + 0 + NXX + XXXX
	101XXXX + 0 + SAC + NXX + XXXX
	101XXXX + 01 + CC + NN
<b>Direct Distance Dial (DDD) dialing to North American and International locations:</b>	
	101XXXX + 1 + NPA + NXX + XXXX
	101XXXX + 1 + NXX + XXXX
	101XXXX + 011 + CC + NN

During the time when both original and expanded CAC formats are supported it should be noted that the original CICs will be supported by the expanded CAC format if “0” is dialed before the original CIC. Table 7 shows the interactions between CAC formats during the various time frames:

**Table 7**  
**CAC format interactions**

Supported CAC formats	Dialing sequences	Example
Original only	10XXX + ...	10123 + 1 + NPA + NXX + XXXX
Original and Expanded	10XXX + ... 1010XXX + ...	10123 + 1 + NPA + NXX + XXXX 1010123 + 1 + NPA + NXX + XXXX
Expanded only	1010XXX + ...	1010123 + 1 + NPA + NXX + XXXX

## Carrier Access Codes dialing sequences with special characters

The Meridian 1 recognizes two special characters in any dialing sequence. These characters are the \* (star or asterisk) and # (number sign, pound, or octothorpe). The \*, when detected in a dialing sequence, causes a pause in the outpulsing of digits, while the #, when detected in a dialing sequence, indicates end-of-dialing, i.e., no further digits are required to process the call.

Due to an interaction with Equal Access if the Meridian 1 is configured to restrict international toll calls, then direct dialed Equal Access operator calls (101XXXX + 0) can not be terminated with an #. If the Equal Access operator call is terminated with an # the call will be restricted. Table 8 depicts this interaction:

**Table 8**  
**Octothorpe with Equal Access interaction**

<b>If</b>	101XXX + 011 + CC + NN	<b>calls are restricted.</b>
<b>Then</b>	101XXX + 0 + #	<b>calls will also be restricted.</b>
<b>But</b>	101XXXX + 0	<b>will not be restricted.</b>

## Configuring Equal Access within a Network

Equal Access toll restriction is intended for use on an outgoing route from a Meridian 1 to a Central Office. This feature is not intended for restriction of calls which terminate on a network node. Therefore, network signaling (ESN3, ESN5, or ETN) is not supported.

Within a network Equal Access toll calls should be restricted at the outgoing node (the node which is directly connected to the Central Office).





Meridian 1  
**Coordinated Dialing Plan**  
Description

Copyright ©1982–2000 Nortel Networks  
All Rights Reserved

Information is subject to change without notice. Nortel Networks reserves the right to make changes in design or components as progress in engineering and manufacturing may warrant. This equipment has been tested and found to comply with the limits for a Class A digital device pursuant to Part 15 of the FCC rules, and the radio interference regulations of the Canadian Department of Communications. These limits are designed to provide reasonable protection against harmful interference when the equipment is operated in a commercial environment. This equipment generates, uses and can radiate radio frequency energy, and if not installed and used in accordance with the instruction manual, may cause harmful interference to radio communications. Operation of this equipment in a residential area is likely to cause harmful interference in which case the user will be required to correct the interference at this own expense.

SL-1 and Meridian 1 are trademarks of Nortel Networks.

Publication number: 553-2751-102  
Document release: Standard 5.00  
Date: April 2000  
Printed in Canada



*How the world shares ideas.*