

---

Meridian 1 and Succession Communication Server for Enterprise 1000

# ISDN Basic Rate Interface

## Product Description

---

Document Number: 553-3901-100

Document Release: Standard 8.00

Date: January 2002

---

Copyright © 1992–2002 Nortel Networks  
All Rights Reserved

Printed in Canada

Information is subject to change without notice. Nortel Networks reserves the right to make changes in design or components as progress in engineering and manufacturing may warrant. This equipment has been tested and found to comply with the limits for a Class A digital device pursuant to Part 15 of the FCC rules, and the radio interference regulations of Industry Canada. These limits are designed to provide reasonable protection against harmful interference when the equipment is operated in a commercial environment. This equipment generates, uses and can radiate radio frequency energy, and if not installed and used in accordance with the instruction manual, may cause harmful interference to radio communications. Operation of this equipment in a residential area is likely to cause harmful interference in which case the user will be required to correct the interference at their own expense.

SL-1, Meridian 1, and Succession are trademarks of Nortel Networks.

---



---

## Revision history

---

### January 2002

Standard 8.00. This document is up-issued to include content changes for Meridian 1 Release 25.40 and Succession Communication Server for Enterprise 1000 Release 1.1.

### April 2000

Standard 7.00. This is a global document and is up-issued for X11 Release 25.0x. Document changes include removal of: redundant content; references to equipment types except Options 11C, 51C, 61C, and 81C; and references to previous software releases.

### April 1999

Issue 6.00 released as Standard for Generic X11 Release 24.0x

### October 1997

Issue 5.00 released as Standard for Generic X11 Release 23.0x.

### August 1996

Issue 4.00 released as Standard for Generic X11 Release 22.0x.

### December 1995

Issue 3.00 released as Standard for Generic X11 Release 21.1x

### July 1995

Issue 2.00 released as Standard for Generic X11 Release 21.0x

### December 1994

Issue 1.00 released as Standard for Generic X11 Release 20.0x.

### July 1994

Standard version issued for Generic X11 Release 19.0x.

**July 1993**

Standard version issued for Generic X11 Release 18.0x.

---

# Contents

---

<b>Revision history</b> .....	<b>3</b>
<b>About this document</b> .....	<b>7</b>
<b>Functional description</b> .....	<b>9</b>
Contents .....	9
Reference list .....	9
Introduction .....	10
Operating parameters .....	10
ISDN Basic Rate Interface overview .....	10
ISDN BRI line access .....	14
ISDN BRI Packet data transmission .....	18
ISDN BRI trunk access .....	25
<b>Engineering guidelines</b> .....	<b>41</b>
Contents .....	41
Reference list .....	42
Introduction .....	42
Hardware Requirements .....	42
Physical capacity .....	67
Memory capacity .....	69
ISDN BRI configuration guidelines .....	75
Transmission characteristics .....	84
ISDN BRI terminal interface specification .....	106

Compatible ISDN BRI terminals .....	108
<b>Features on ISDN BRI .....</b>	<b>109</b>
Reference .....	109

## About this document

---

This document describes Integrated Services Digital Network Basic Rate Interface (ISDN BRI) concepts, functional and physical characteristics of ISDN Basic Rate operation, and general engineering guidelines on configuring ISDN BRI functions and features.

This document is a global document. Contact your system supplier or your Nortel Networks representative to verify that the hardware and software described is supported in your area.





---

# Functional description

---

## Contents

The following are the topics in this section:

Introduction . . . . .	10
Operating parameters . . . . .	10
ISDN Basic Rate Interface overview . . . . .	10
General ISDN BRI capabilities . . . . .	12
The OSI model . . . . .	13
ISDN BRI line access . . . . .	14
S/T interface configured for line access . . . . .	14
U interface configured for line access . . . . .	16
ISDN BRI Packet data transmission . . . . .	18
Packet data transmission using the DPN-100 . . . . .	18
Packet data transmission using the Meridian 1 Packet Handler . . . . .	21
ISDN BRI trunk access . . . . .	25
ISDN BRI Local Exchange/CO/DID connectivity . . . . .	27
Clock synchronization, automatic switching and recovery for	
ISDN BRI to local exchange connectivity . . . . .	32
ISDN BRI MCDN Tie trunk connectivity . . . . .	34
ISDN BRI QSIG connectivity . . . . .	37

## Reference list

The following are the references in this section:

- *ISDN Basic Rate Interface: Installation (553-3901-200)*

## Introduction

This chapter describes ISDN BRI system functions, the operation of the Multi-Purpose ISDN Signaling Processor (MISP), the Basic Rate Signaling Concentrator (BRSC), the S/T Interface Line Card (SILC), the U Interface Line Card (UILC), and the two forms of packet handlers - external and integrated. It also describes the Digital Subscriber Loop (DSL) concepts and how to initialize and assign service attributes to ISDN BRI terminals and trunks assigned to a DSL.

## Operating parameters

Please note the following important operating parameters pertaining to ISDN BRI functionality:

- ISDN BRI trunk access is not supported in North America
- the integrated Meridian 1 Packet Handler is not supported on Option 11C
- the Basic Rate Signaling Concentrator (BRSC) is not supported on Option 11C

## ISDN Basic Rate Interface overview

ISDN Basic Rate Interface (ISDN BRI) is a digital connection that provides three digital channels. These channels consist of two 64 kbps Bearer channels (B-channels) and one 16 kbps signaling channel (D-channel). This 2B+D connection is known as a Digital Subscriber Loop (DSL). The DSL can be configured to provide line access, trunk access, or packet data transmission.

**Line Access** provides a digital connection from a Meridian 1 ISDN BRI card to ISDN terminals that comply with CCITT, ANSI, ETSI NET-3 and ETS 300 403 (including EuroISDN), INS NET-64 (including Japan D70), National ISDN-1 (NI-1), 1TR6, and Numeris VN2 standards; examples of terminals are telephone sets, FAX machines, personal computers and video display terminals.

**Trunk Access** provides Meridian Customer Defined Networking (MCDN) Tie trunk connectivity between Meridian 1 systems, QSIG ISDN BRI trunk connectivity, and CO/DID trunk connectivity to local exchanges that support Numeris VN3, 1TR6, ETSI NET-3 and ETS 300 403 (EuroISDN), INS NET-64 (including Japan D70), Australia ETSI, and Asia-Pacific protocols.

*Note:* ISDN BRI trunk access is not supported in North America.

The Meridian 1 supports both B-channel and D-channel **packet data** transmission through an external DPN-100 packet handler, or an integrated Meridian 1 Packet Handler (MPH).

*Note:* The integrator MPH is not supported on Option 11C.

### **B-channels and D-channel**

B-channels can be automatically assigned and reassigned to different voice and data terminals in circuit-switched applications, they can be dedicated to specific terminals for packet data applications, or configured for ISDN BRI trunk applications.

For ISDN BRI line access, the ability to dynamically connect different terminals on one DSL provides more flexibility, connectivity, and service diversity than the conventional “hard wired” connections where each channel is dedicated to one terminal. The D-channel is used for signaling and low speed packet data transmission.

For ISDN BRI trunk access, one ISDN BRI trunk may be assigned to each B-channel in the 2B+D configuration. The D-channel is used for signaling.

### **ISDN BRI interfaces to the Meridian 1**

ISDN BRI provides two types of interface to the Meridian 1 — the S/T interface or an U interface. The DSLs may be configured for either an S/T or U interface, and may be configured for either line or trunk access.

The **S/T interface** is a globally accepted standard interface. This interface is provided by the SILC line card, which supports 8 DSLs.

The **U interface** is implemented as an ANSI standard interface only (2B1Q line encoding). This interface is provided by the UILC line card, which also supports 8 DSLs.

### **Data link and network processing**

The ISDN BRI data link and network layering processing functions are carried out by the **Multi-Purpose ISDN Signaling Processor (MISP)**, or the **Basic Rate Signaling Concentrator (BRSC)**; these functions, as well as the functions of the other system hardware, are detailed in the “Engineering guidelines” section of this document.

*Note 1:* The BRSC is not supported on Option 11C.

*Note 2:* The BRSC cannot be used for trunk access. Therefore, the BRSC only performs the data link processing.

### **General ISDN BRI capabilities**

The most important capabilities of ISDN BRI are:

- for line access
  - simultaneous voice and circuit-switched data over a single DSL
  - B-channel and/or D-channel packet data transmission over a single DSL
  - multiple physical terminals connected to a single DSL
  - multiple logical devices associated with each DSL
  - diverse ISDN-compliant third party terminals (compliant with CCITT, ANSI, ETSI NET-3 and ETS 300 403, INS NET-64, National ISDN-1, 1TR6, Numeris VN2, and EuroISDN standards)
- for trunk access
  - MCDN ISDN BRI Tie trunk connectivity
  - QSIG ISDN BRI Tie trunk connectivity
  - CO/DID trunk connections to local exchanges that support Numeris VN3, 1TR6, ETSI NET-3 and ETS 300 403 (EuroISDN), INS NET-64 (Japan D70), Australia ETSI, and Asia-Pacific protocols

## The OSI model

ISDN standards follow the Open System Interconnect (OSI) protocol model to control ISDN functions. The OSI model defines seven layers required to perform all ISDN functions from establishing an end-to-end connection between two terminals or trunks, to making a decision about the type of application that is to be activated. Figure 1 shows the seven layer OSI model. ISDN BRI utilizes only the first three layers. These are:

- **Physical layer** (layer 1) that provides a network-to-terminal or trunk connection (**SILC/UILC**).
- **Data link layer** (layer 2) that provides signaling used to establish a communication link between terminals or trunks over ISDN (point-to-point signaling for terminals, and point-to-multipoint signaling for trunks). It also performs some error checking and error recovery (**MISP/BRSC**).
- the BRSC applies to terminals only.
- **Network layer** (layer 3) that controls initialization procedures and assigns service attributes to terminals and trunks. It also controls the call processing procedures (**MISP, MPH**).

Once these three layers are established, the functional role of ISDN BRI in the OSI protocol sequence is complete. The higher layers of the OSI protocol model are handled by the end-user application software.

Figure 1  
OSI model

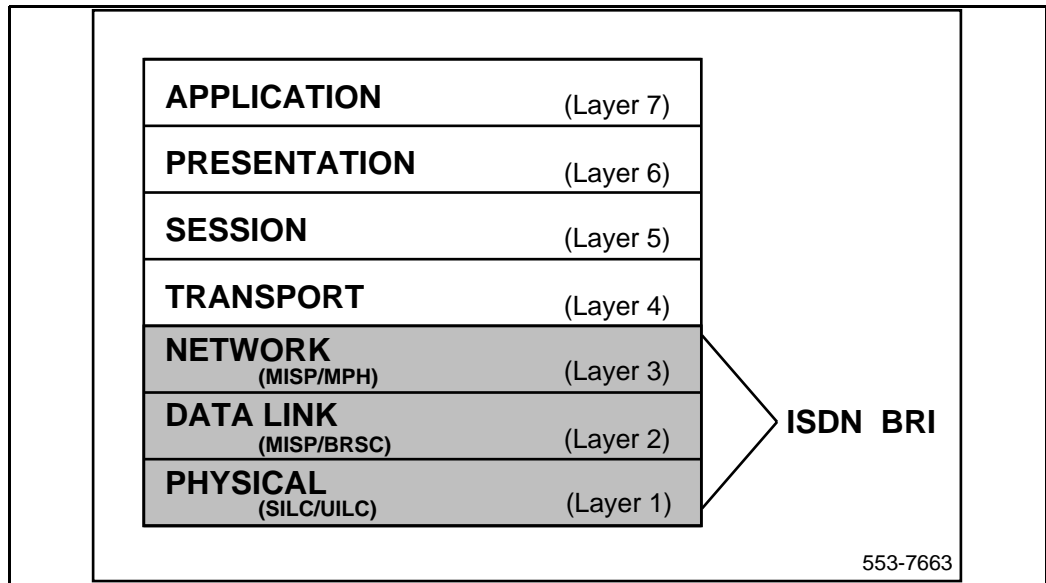

## ISDN BRI line access

ISDN BRI line access provides 2B+D ISDN service to terminating equipment such as ISDN telephone sets and data terminals. ISDN BRI line connections are configured on a per DSL basis, that is, DSL line connections may be configured on any given DSL for any SILC or UILC.

The B-channels are dynamically assigned to different voice and data terminals in circuit-switched line applications. In case of packet data applications, the B-channels are dedicated connections. The D-channel is used for signaling and dynamic D-channel packet data.

## S/T interface configured for line access

Figure 2 illustrates a typical ISDN BRI configuration showing a Meridian 1 with an ISDN BRI S/T interface and the ISDN BRI terminals connected to it; the terminals must comply with CCITT, ANSI, ETSI NET-3 (including EuroISDN), INS NET-64 (including Japan D70), National ISDN-1, 1TR6, and Numeris VN2 standards.

The S/T interface is a four-wire, polarity-sensitive interface which, configured for line application, can support eight physical voice and data terminals, and up to 20 logical terminals on one DSL. A physical terminal is any device directly connected to a DSL. The terminals labeled 1, 2 and 3 in Figure 2 are physical terminals.

A logical terminal (terminal 4 in Figure 2) is any terminal that can communicate with the Meridian 1 over a DSL. It may be directly connected to the DSL through its own physical termination or it may be indirectly connected through a common physical termination. Please refer to the “Terminal addressing and service profile assignment” section of the Engineering Guidelines chapter for an illustration of how a single physical termination may actually connect multiple logical terminals. All of the logical terminals connected to the DSL share the two B-channels provided by the S/T interface.

**Note:** The Terminal Adapter (TA) that is shown in the illustration is used to adapt non-ISDN BRI terminals to ISDN BRI line interface standards.

The length of an S/T interface DSL depends on the specific terminal configuration and the DSL wire gauge, however, it should not exceed 1 km (3280 ft).

**Figure 2**  
**ISDN Basic Rate Interface S/T interface configured as a line**

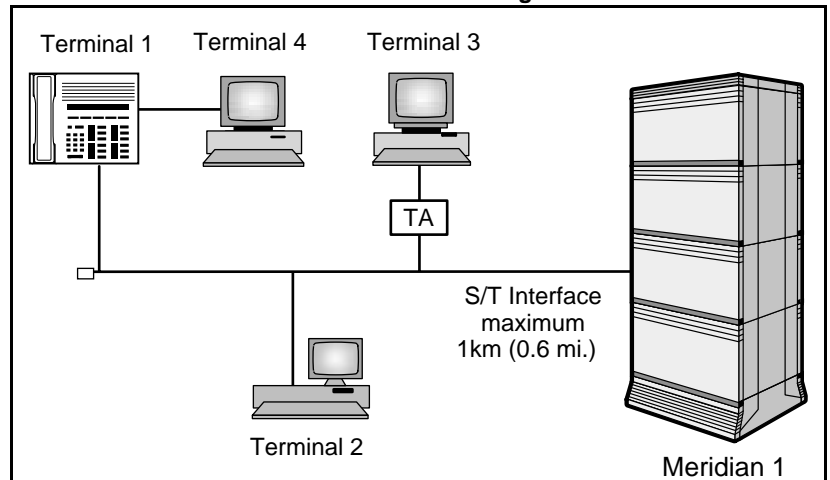

## U interface configured for line access

The U interface is a two-wire interface that provides point-to-point connection over a DSL. Each U interface provides two B-channels and one D-channel and supports only one physical termination. This termination may be to a Network Termination 1 (NT1) or directly to a single U interface terminal that contains an internal NT1. Normally this physical termination is to an NT1, which provides a conversion from a U interface to an S/T interface that allows up to eight physical terminals to be connected.

The length of a U interface DSL depends on the specific terminal configuration and the DSL wire gauge, however, it should not exceed 5.5 km (3.3 mi). When connected to an NT1 the DSL length is effectively extended to 6.5 km (3.9 mi) and utilizes the multi-terminal capability of an S/T interface.

Figure 3 illustrates a typical ISDN BRI configuration showing a Meridian 1 with an ISDN BRI U interface. ISDN BRI terminals can be connected to the NT1 through the S/T interface; the terminals must comply with CCITT, ANSI, ETSI NET-3 (including EuroISDN), INS NET-64 (including Japan D70), National ISDN-1, 1TR6, Numeris VN2 standards), Australia ETSI, and Asia-Pacific protocols.



**Figure 3**  
**ISDN Basic Rate Interface U interface configured as a line**

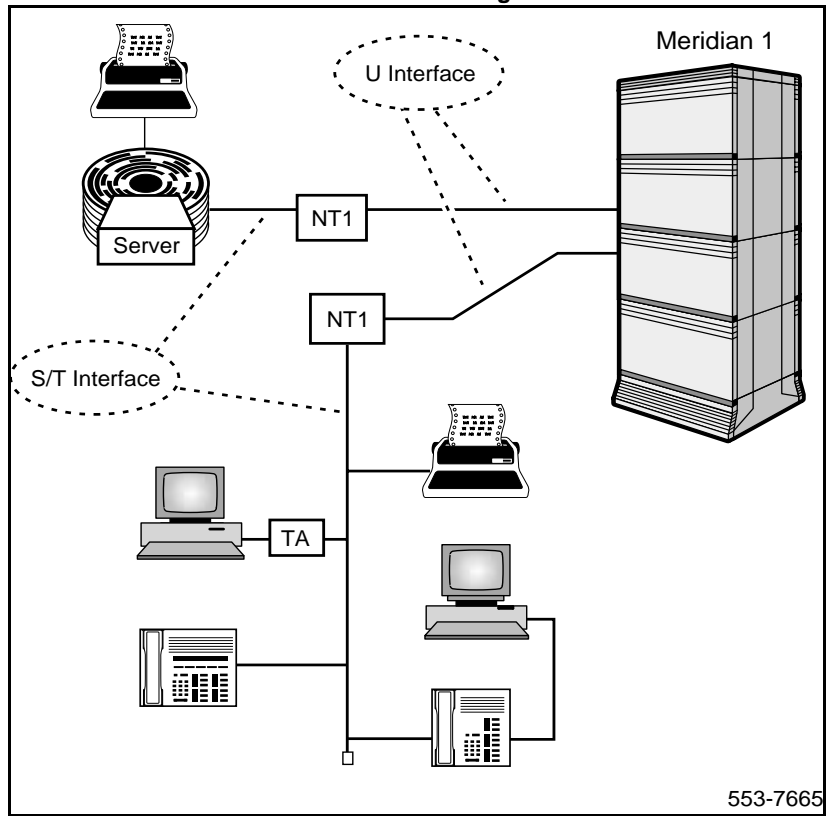

### 1TR6 terminal connectivity

1TR6 terminals may be connected to the Meridian 1 using a protocol adapter, which has been specifically designed to interface with Meridian 1 ISDN BRI and 1TR6 terminals. Its main function is to convert the 1TR6 protocol sent from the 1TR6 ISDN Terminal Equipment into the European Telecommunication Standard Institute (ETSI) protocol required for ISDN BRI, and vice versa. This conversion is necessary because the layer 3 requirements for 1TR6 and ETSI are different.

Figure 4 shows a 1TR6 ISDN BRI terminal connected to the protocol adapter, which is used to access the Meridian 1 through an S/T interface.

**Figure 4**  
**An example of an ISDN BRI/1TR6 terminal connectivity**

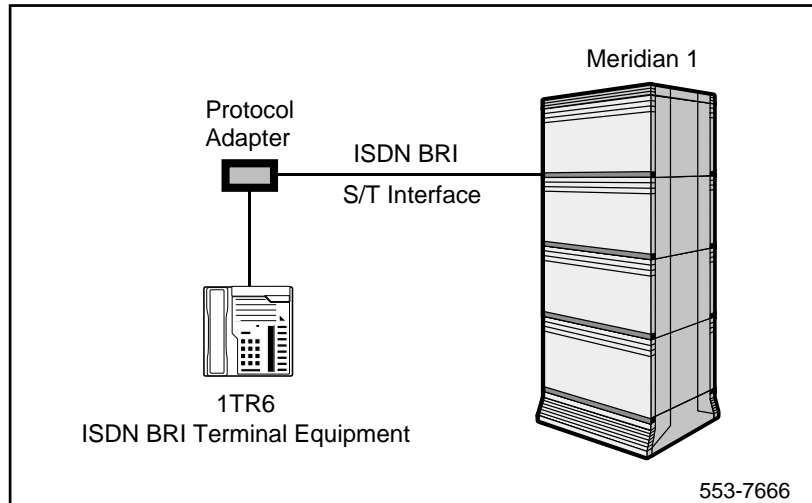

## ISDN BRI Packet data transmission

Packet switching differs from circuit switching in that the content of the call is switched rather than the call itself. The message that is being transmitted is broken down into packets that are then sent to their destination through the fastest route.

ISDN BRI on the Meridian 1 supports both B-channel and D-channel packet data transmission. Packet data transmission is done using either an external packet handler, via Nortel Networks Data Packet Network (DPN-100), or the integrated Meridian 1 Packet Handler (MPH).

*Note:* When reading this section, please note that the integrated MPH and the BRSC are not supported on Option 11C.

### Packet data transmission using the DPN-100

#### B-channel packet data transmission

The B-channel packet data from each DSL is transmitted over dedicated connections from the SILC or UILC card to a PRI card, and then over PRI B-channels to the external packet data handler (DPN-100).

The B-channels on a DSL are dedicated to packet data transmission during ISDN BRI service configuration. The number of B-channel connections is limited to the number of available ISDN PRI channels.

### **D-channel packet data transmission**

D-channel packet data from each DSL is transmitted to the MISP or BRSC for separation. The MISP or BRSC separates the packet data from signaling and transmits the packet data to the ISDN PRI. From the ISDN PRI, the data is transmitted to the external packet handler over 64 kbps clear channels.

If the system is to uniquely identify the transmitted and received D-channel packet data for each terminal on a DSL, the Meridian 1 must use an internal identification number. This identification number is called Logical Terminal Identifier (LTID), which must be used together with the Logical Terminal End-point Identifier (LTEI) number during ISDN BRI configuration to uniquely define a logical terminal on a DSL. The LTEI is configured in Overlay 27.

D-channel packet data service is determined separately for each MISP or BRSC during ISDN BRI service configuration.

Figure 5 illustrates the Meridian 1 external packet handling flow diagram, showing the B-channel and the D-channel packet data routes starting at the line cards and arriving at the external packet handler through dedicated B-channels and dedicated D-channels. Figure 6 presents the same concept, with the addition of a BRSC.

Figure 5  
Packet data transmission using the external packet handler

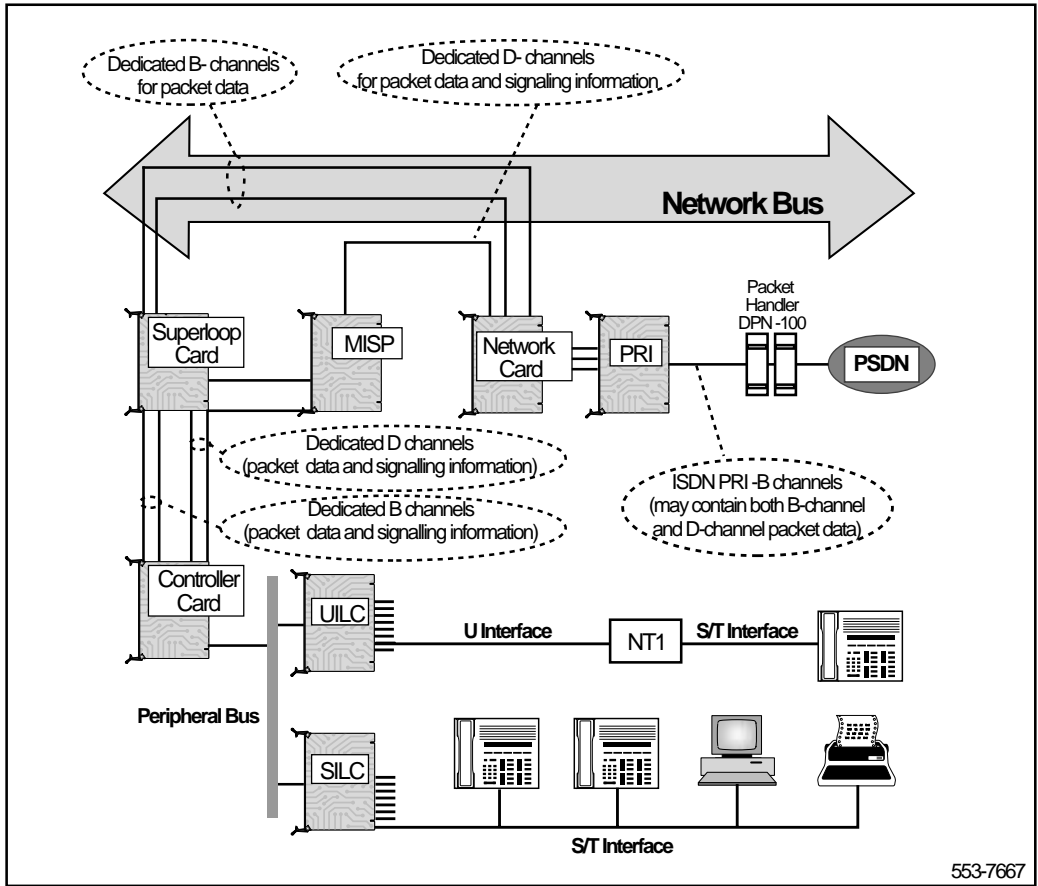

**Figure 6**  
**Packet data transmission using the external packet handler configured with a BRSC**

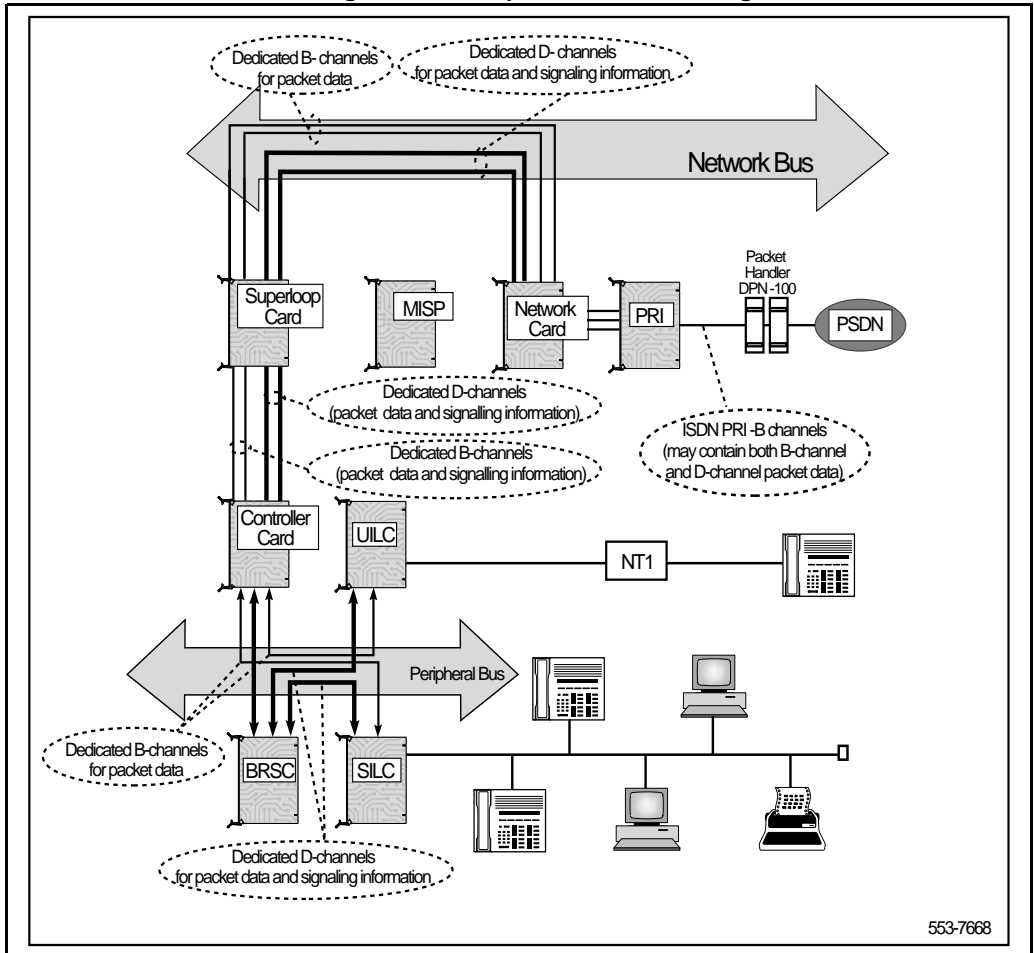

**Packet data transmission using the Meridian 1 Packet Handler**

*Note:* This information does not apply to Option 11C.

The Meridian 1 Packet Handler (MPH) uses a dedicated MISP as a hardware platform to run the packet handler application. Routing from the MPH to the PSDN is through dedicated connections either from a Meridian Communication Unit (MCU) data module and a synchronous modem, or from a dedicated ISDN PRI B-channel (64 kbps clear).

The MPH supports both B-channel and D-channel packet data transmission.

### **D-channel packet data transmission with the MPH**

The MISP line application or the BRSC(s) separate the D-channel packet data from signaling and transmit the data packets on a dedicated PRI D-channel over its network connection to the MPH.

When using an MPH, the digital subscriber loop (DSL) and the Terminal Endpoint Identifier (TEI) are used to identify the Logical Terminal instead of the Logical Terminal Identifiers (LTIDs) which is used by the DPN-100 configuration.

The TEI uniquely identifies to the MPH the transmitted and received packet data for each terminal on a DSL. The TEI number is entered during ISDN BRI configuration to uniquely define a logical terminal on a DSL for the MISP. To configure a terminal for D-channel packet data service, a specific TEI is assigned to an unused static TEI and this information is sent to the MISP.

D-channel packet data service is determined separately for each MISP or BRSC during ISDN BRI configuration. When this data transmission method is selected during system configuration, the user is prompted to enter the MPH loop number to specify the dedicated connection to the MPH. The Meridian 1 CPU sets up the dedicated D-channel to the MPH and informs the MISP or BRSC on which network connection the dedicated D-channel is located.

### **B-channel packet data transmission with the MPH**

B-channel packet data is routed to the MPH directly through dedicated connections. The MPH routes B-channel packet data to the Packet Switched Data Network (PSDN) by means of dedicated channels through either the PRI B-channel (64 kbps clear) or through a Meridian Communication Unit (MCU) with a synchronous modem.

The B-channel packet data from each DSL is routed to the Controller and Superloop network cards. From the Superloop network card, the data is sent to the MPH.

The B-channels on a DSL are dedicated to the packet data transmission by assigning the internal packet data call type to one or more B channels on one or more DSLs during ISDN BRI configuration. These dedicated channels cannot be released by the B-channel packet data terminal. The user is prompted to enter the MPH loop and channel number to specify the dedicated connection to the MPH.

### **Packet data transmission between the MPH and the PSDN**

If using an MPH with an ISDN PRI loop, configure the ISDN PRI loop (LD 17), define an ISDN customer (LD 15), define a Tie trunk route for packet data (LD16), and define a Tie trunk for packet data (LD 14). Then, configure the MISP for an MPH (LD 27).

If using an MPH with an MCU data module, define a Tie trunk route for packet data (LD 16), define a Tie trunk for packet data (LD 14), and configure the MCU (LD 11). Then, configure the MISP for an MPH (LD 27).

Figure 7 illustrates packet data transmission for ISDN BRI line application, using the MPH.

Figure 7  
Packet data transmission using the MPH

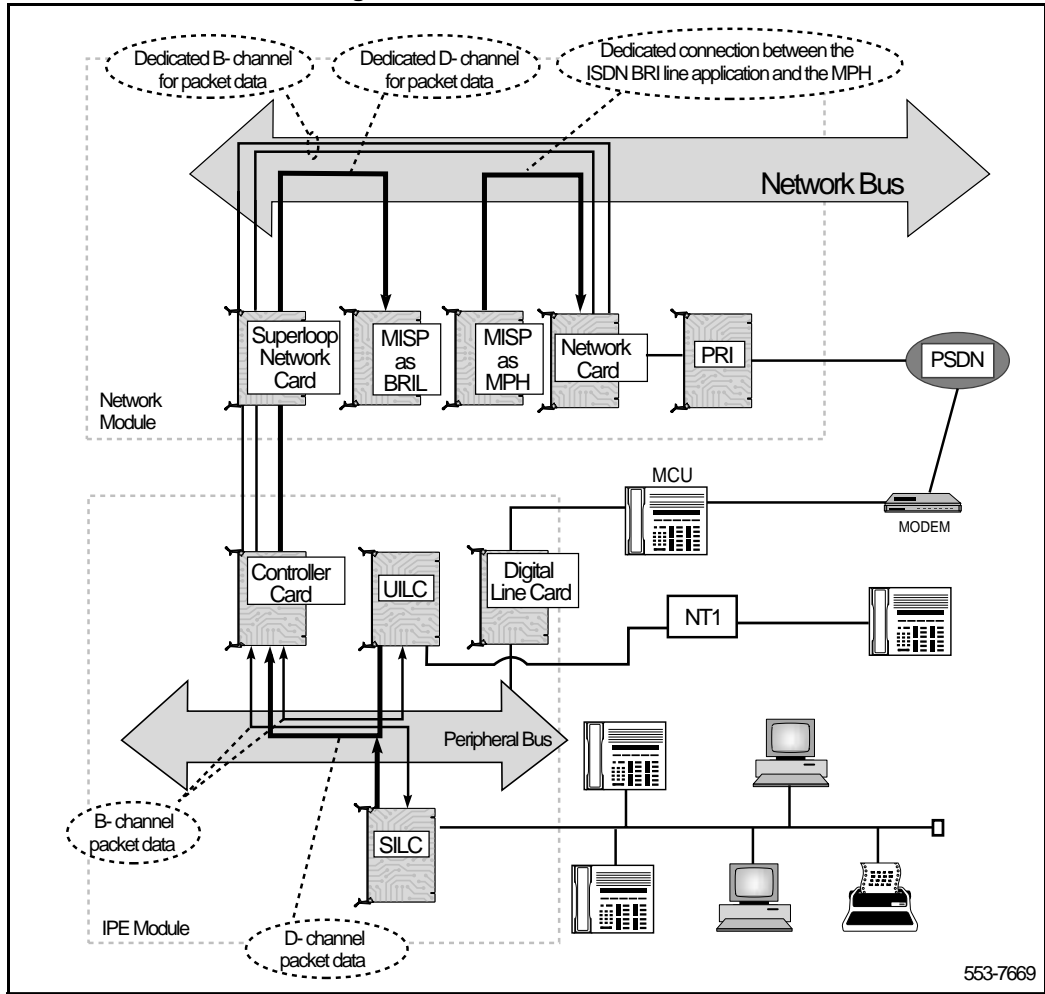
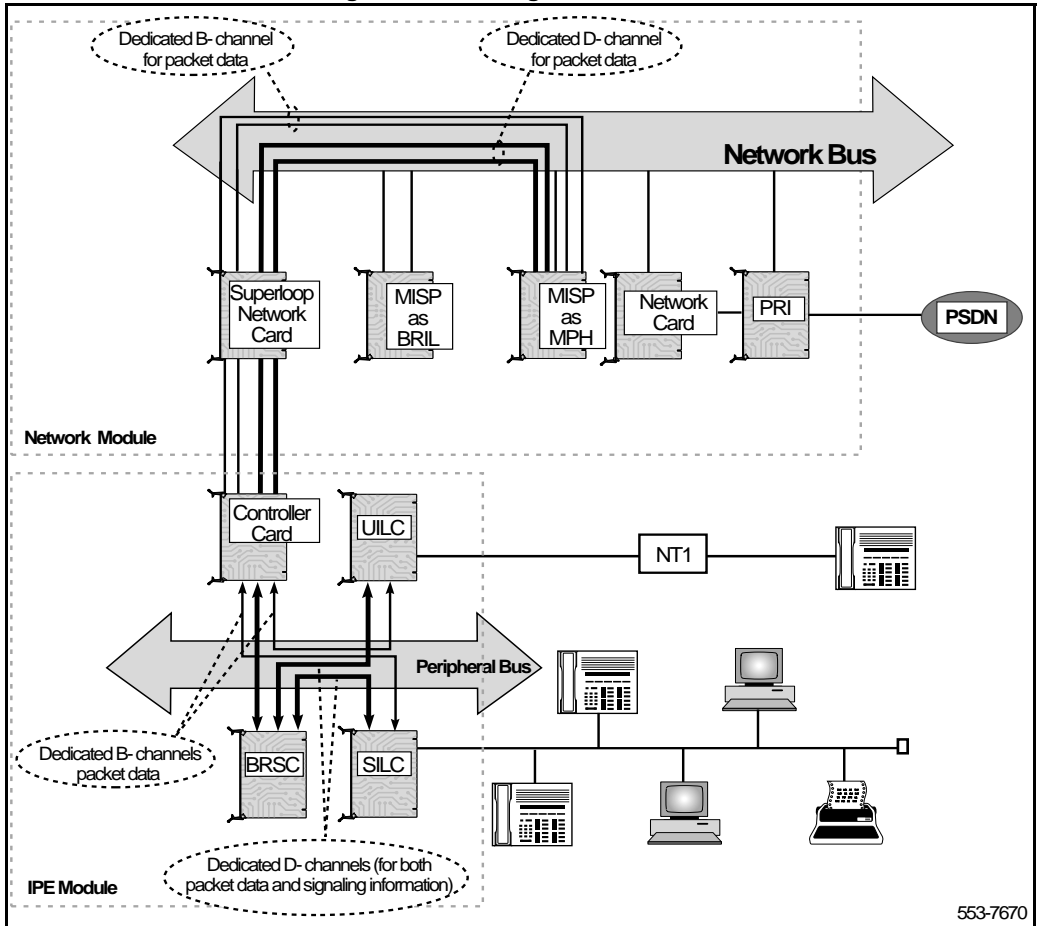

Figure 8 illustrates packet data transmission for an ISDN BRI line application, using the MPH and configured with a BRSC.



**Figure 8**  
**Packet data transmission using the MPH configured with a BRSC**



## ISDN BRI trunk access

*Note:* ISDN BRI trunk access is not supported in North America.

ISDN BRI trunks may be configured for either local exchange/CO/DID trunk connectivity, MCDN Tie trunk connectivity, or QSIG trunk connectivity. ISDN BRI trunk connections are configured on a per DSL basis, that is, DSL trunk connections may be configured on any given DSL for any SILC or UILC. The trunks can be accessed using both ISDN BRI terminals and non ISDN BRI devices (such as digital and analog telephones).

**ISDN BRI Local exchange CO/DID connectivity** is accomplished via a MISP card and an S/T interface, using the SILC line card. This connectivity is supported for Numeris VN3, 1TR6, ETSI NET-3 and ETS 300 403 (EuroISDN), INS NET-64 (Japan D70), Australia ETSI, and Asia-Pacific protocols. Refer to Figure 9.

**ISDN BRI MCDN Tie trunk connectivity** is achieved via an MISP card and either S/T or U interfaces, using the SILC and UILC line cards respectively. This connectivity may be:

- between two Meridian 1 PBXs through a local exchange acting as a passive facility; the local exchange must support Numeris VN3, 1TR6, ETSI NET-3 and ETS 300 403 (EuroISDN), INS NET-64 (Japan D70), Australia ETSI, or Asia-Pacific protocols; refer to Figure 10.
- directly between two Meridian 1 PBXs; refer to Figure 11 and Figure 12.

**ISDN BRI QSIG connectivity** is achieved through an MISP card and either S/T or U interfaces, using the SILC and UILC line cards respectively. This connectivity is supported within a Private Telecommunications Network (PTN) between two Private Telecommunications Network Exchanges (PTNXs). Examples may be a Centrex-to-Centrex connection, or a Centrex-to-PBX connection. Refer to Figure 13 in the section “ISDN BRI QSIG connectivity” on page 37.

*Note:* The BRSC cannot be utilized for ISDN BRI trunk access.

These configurations are explained in greater detail in the sections that follow.

## ISDN BRI Local Exchange/CO/DID connectivity

ISDN BRI Local Exchange connectivity is supported in markets equipped with local exchanges that conform to Numeris VN3, 1TR6, ETSI NET-3 and ETS 300 403 (EuroISDN), INS NET-64 (Japan D70), Australia ETSI, or Asia-Pacific protocols.

Figure 9 illustrates the ISDN BRI Local Exchange connectivity. The ISDN BRI Local Exchange DSL is connected to a Network Termination (NT1) device, which is physically located on the same premises as the Meridian 1. The NT1 device connects to the Local Exchange via a U interface. (The NT1 device is typically owned by the Local Exchange/Post Telegraph and Telephone allowing the Local Exchange/PTT to use any type of U interface, including proprietary implementations). The distance limitation of the NT1 from the Local Exchange depends on the distance supported by the Local Exchange.

**Figure 9**  
**ISDN BRI trunk access for local exchange connectivity**

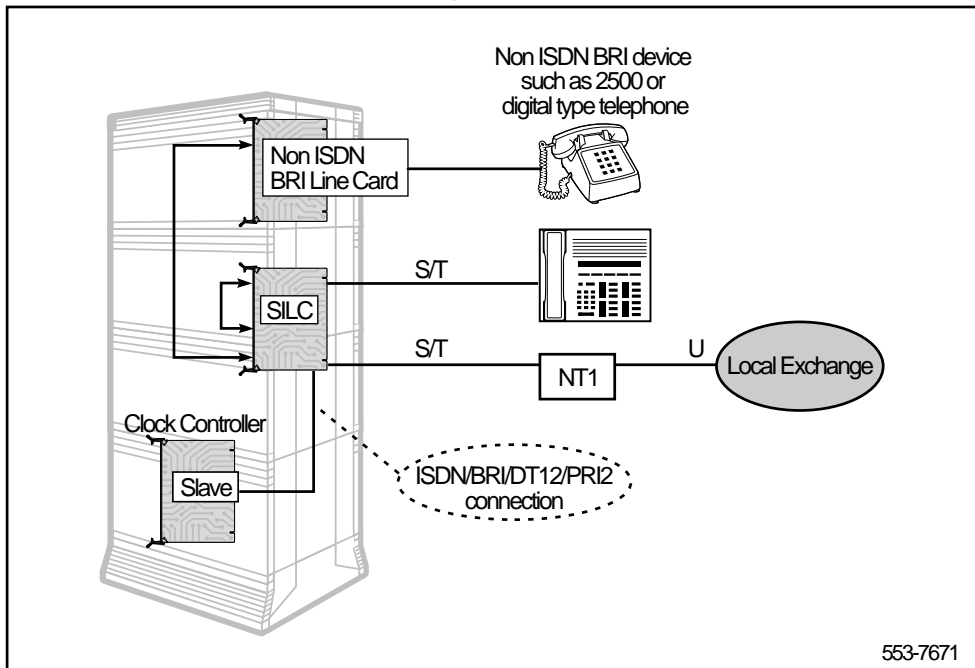

### **1TR6 local exchange connectivity**

1TR6 local exchange connectivity provides 2B+D connectivity to a local exchange that supports 1TR6 protocol via an S/T interface. The ISDN BRI 1TR6 local exchange connectivity provides the following basic call and supplementary services:

*Note:* Support for any feature is dependent upon the terminal equipment being used.

- Basic call service
- Circuit switched voice and data on the B-channel
- Calling Line Identification Presentation and Restriction
- Connected Number Delivery
- Support for TIE, COT, DID, DOD trunk types
- Channel negotiation

*Note:* in cases where several ISDN BRI trunks (and hence several DSLs) are configured on a route, if Channel Negotiation fails to yield an acceptable channel on any of these DSLs, it is not possible to use another channel on another DSL.

- Overlap sending
- Flexible Numbering Plan
- Indication of Call Charging to the calling party
- Network-wide interworking with ISDN BRI ETSI terminals

### **Numeris VN3 local exchange connectivity**

The Numeris local exchange connectivity provides 2B+D connectivity through an S/T interface to a local exchange that supports Numeris VN3 protocol. The ISDN BRI/Numeris VN3 local exchange connectivity provides the following basic call and supplementary services:

- Basic call service
- Circuit switched voice and data on the B-channel
- Called/calling party subaddress (network-wide)

- Support for TIE, COT, DID, DOD trunk types
- Channel negotiation
- In cases where several ISDN BRI trunks (and hence several DSLs) are configured on a route, if Channel Negotiation fails to yield an acceptable channel on any of these DSLs, it is not possible to use another channel on another DSL.
- 64 kbps clear bearer capability
- Flexible Numbering Plan
- Advice of charge during call and at end of call
- Network-wide interworking with ISDN BRI Numeris terminals

### **Japan D70 (INS NET-64) local exchange connectivity (non-Asia Pacific protocol)**

The Japan D70 (INS NET-64) local exchange connectivity (non-Asia Pacific protocol) provides 2B+D connectivity through an S/T interface to a local exchange that supports the D70 protocol (D70 is the Japanese version of the INS NET-64 protocol). The ISDN BRI/Japan D70 local exchange connectivity provides the following basic call and supplementary services:

- Basic call service
- Circuit switched voice and data on the B-channel
- Called/calling party subaddress (network-wide)
- Support for TIE, COT, DID, DOD trunk types
- 64 kbps clear bearer capability
- Flexible Numbering Plan
- Advice of charge at end of call
- Channel Negotiation

**Note:** in cases where several ISDN BRI trunks (and hence several DSLs) are configured on a route, if Channel Negotiation fails to yield an acceptable channel on any of these DSLs, it is not possible to use another channel on another DSL.

### **EuroISDN connectivity**

The EuroISDN connectivity provides an interface between Meridian 1 PBXs and Central Offices/Public Exchanges that comply to the European Telecom Standards Institute (ETSI) specification ETS 300 102 for the Layer 3.

The interfaces provided by this feature also comply with the country-specific Application Documents for Austria, Belgium, Commonwealth of Independent States (Russia and the Ukraine), Denmark, Finland, Germany, Holland, Ireland, Italy, Norway, Portugal, Spain, Sweden, Switzerland, and the United Kingdom.

The Meridian 1 on the EuroISDN connectivity provides the following call services, for the complying markets:

- Basic call service
- Circuit switched voice and data on the B Channel
- Calling Line Identification Presentation and Restriction (CLIP and CLIR)
- Connected Line Presentation and Restriction
- Calling and connected sub-addresses
- Support for TIE, COT, DID, and DOD trunk types
- Overlap sending and receiving
- Overlap and enbloc dialing
- Flexible Numbering Plan
- Channel negotiation

*Note:* in cases where several ISDN BRI trunks (and hence several DSLs) are configured on a route, if Channel Negotiation fails to yield an acceptable channel on any of these DSLs, it is not possible to use another channel on another DSL.

### **Asia-Pacific connectivity**

The ISDN PRI Meridian 1 to Asia Pacific connectivity provides ISDN Primary Rate Interface (PRI) connectivity between the Meridian 1 and Public Exchange/Central Offices in the following Asia Pacific markets:

- Australia (private or alternative carrier)

- China
- Hong Kong
- India
- Indonesia
- Japan
- Malaysia
- New Zealand
- Philippines
- Singapore
- Taiwan
- Thailand

The Asia Pacific connectivities support the following ISDN features:

- Basic Call Service
- Back-up D-channel, for Hong Kong
- Advice of Charge, for Japan (considered a basic service)
- Malicious Call Trace, for Australia
- Advice of Charge (AOC) at End of Call, for Australia
- Incoming Trunk Programmable CLID for analog trunks, for Australia. This feature is available for use in a private or alternative carrier network, as required in Australia.
- nB+D, for Japan (up to 215 B-channels/nine interfaces), for New Zealand (up to 120 B-channels/four interfaces), for Malaysia (up to 120 B-channels/four interfaces); this also applies for Hong Kong
- Calling Line Identification Presentation and Restriction (CLIP and CLIR)
- Connected Line Identification Presentation and Restriction (COLP and COLR), for India, Philippines, Taiwan, and Indonesia
- Circuit switched voice and data on the B-channel

- Direct Dialing Inward (DDI/DID), for Indonesia
- Overlap Sending (supported by all interfaces except Japan, Philippines)
- Overlap Receiving, for India, Indonesia, China, Malaysia, and Thailand
- COT, DID, DOD, and TIE trunk call types, as applicable
- 64 kbps clear digital information
- Flexible Numbering Plan
- Sub-addressing (supported only when information is received from the Asia Pacific ISDN interfaces and passed through a tandem node)
- Channel Negotiation (for all countries except Singapore. See the note which follows).

*Note 1:* As part of the Singapore enhancement, Channel Negotiation is not supported for Singapore. The CNEG option must be set to 1 (the default) in LD 17.

*Note 2:* The Asia Pacific interface does not support the Meridian 1 Packet Handler (MPH) across the CO.

## **Clock synchronization, automatic switching and recovery for ISDN BRI to local exchange connectivity**

System clock synchronization may be achieved by having the Meridian 1 slave to the local exchange; the clock source may be derived either from the ISDN BRI Local Exchange connection or from other ISDN BRI/PRI/DTI local exchange connections if available.

The clock source is input to the Clock Controller card on the Meridian 1, and the system clock is then synchronized with the network clock. This functionality is shown in Figure 10.

Refer to *ISDN Basic Rate Interface: Installation (553-3901-200)* for procedures on how to provide clock references to the Clock Controller in an ISDN BRI local exchange connectivity.



### Automatic switching

The S/T software cannot detect misframes, loss of signal, and bit error rates, conditions that would cause automatic switching of the clock source; rather, the S/T relies on the clock controller to provide feedback on the quality of the clock, and performs automatic switching and recovery as appropriate. If a clock controller error is detected, the system switches to the backup clock controller, without affecting the reference clock that is being tracked.

If the SILC DSL with clock reference is disabled, and re-enabled, clock tracking is restored as follows:

- if DSL #0 has been assigned as the primary reference clock, but the clock controller is tracking on the secondary reference or is in free run mode, the clock is restored to tracking on primary;
- if DSL #1 has been assigned as the secondary reference clock, but the clock controller is in free run mode, the clock is restored to tracking on secondary.

Tracking on the primary or secondary reference clock is automatically switched as follows:

- if the system software is unable to track on the assigned primary reference clock, it switches to the secondary reference clock;
- if the system software is unable to track on the assigned secondary reference clock, it switches to free run mode.

### Clock recovery

The SILC is configured in the slave-slave mode when acting as a trunk interface. This is set up through the Maintenance Signaling Channel (MSC). The microcontroller configures the S/T chips on the SILC as appropriate.

Automatic clock recovery is done upon the expiration of the free run guard timer. Tracking is restored to the primary reference clock, if defined. If the primary reference clock is disabled, tracking is restored to the secondary reference clock, if defined.

### T0 (2B+D) backup for T2 (30B+D)

*Note:* Japan D70 connectivity uses T0 (2B+D) for T1 (23B+D) backup.

When configuring clock synchronization, ISDN BRI trunks can be configured as backup for ISDN PRI trunks using either ESN Route Selection, or Route Hunting. Clock synchronization may be set up with the ISDN BRI clock source configured as a secondary clock reference for an existing ISDN PRI clock source.

Although the reverse is supported, that is, the ISDN BRI clock source may be configured as the primary clock reference with the ISDN PRI clock source as the secondary reference, this configuration is not recommended because a ISDN PRI clock source is more reliable than an ISDN BRI clock source.

### **ISDN BRI MCDN Tie trunk connectivity**

MCDN ISDN BRI Tie trunk connectivity may have three implementations. In the first configuration (refer to Figure 10), a Meridian Customer Defined Networking (MCDN) Tie trunk connection may be implemented by connecting two Meridian 1s to the ISDN BRI leased line through the local exchange via two SILC cards. The S/T interface is connected to the local exchange using the NT1 supplied by the PTT.

There is no distance limitation on this configuration. System clock synchronization may be achieved by having the Meridian 1 slave to the local exchange; the clock source may be derived either from the ISDN BRI local exchange connections or from other ISDN BRI/PRI/DTI local exchange connections if available.

**Figure 10**  
**ISDN BRI trunk access Tie trunk connectivity — first configuration, as described above**

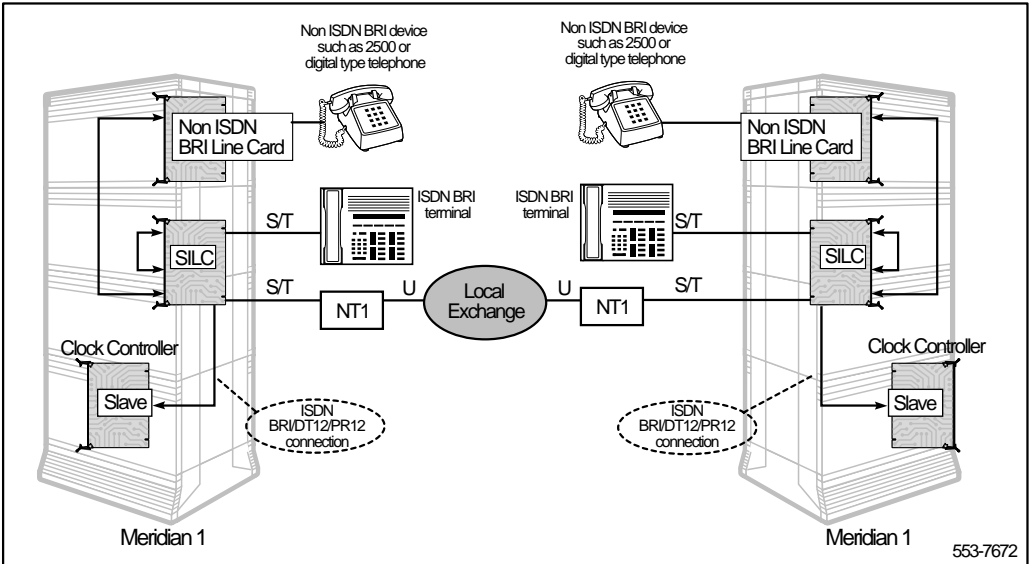

In the second configuration (Figure 11), an MCDN Tie trunk connection may be achieved by connecting two Meridian 1s through an NT1 device. With this configuration, there is a distance limitation of 6.5 km (3.9 miles), without any signal amplification device.

System clock synchronization may be achieved by having the Meridian 1, equipped with the SILC, derive clock reference from the ISDN BRI Tie trunk connection or from other ISDN BRI/PRI/DTI connections if available. The Meridian 1 equipped with the UILC interface may be allowed to operate in free-run mode or derive the clock source from other ISDN BRI/PRI/DTI connections if available.

**Figure 11**  
**ISDN BRI Tie trunk connectivity — second configuration, as described above**

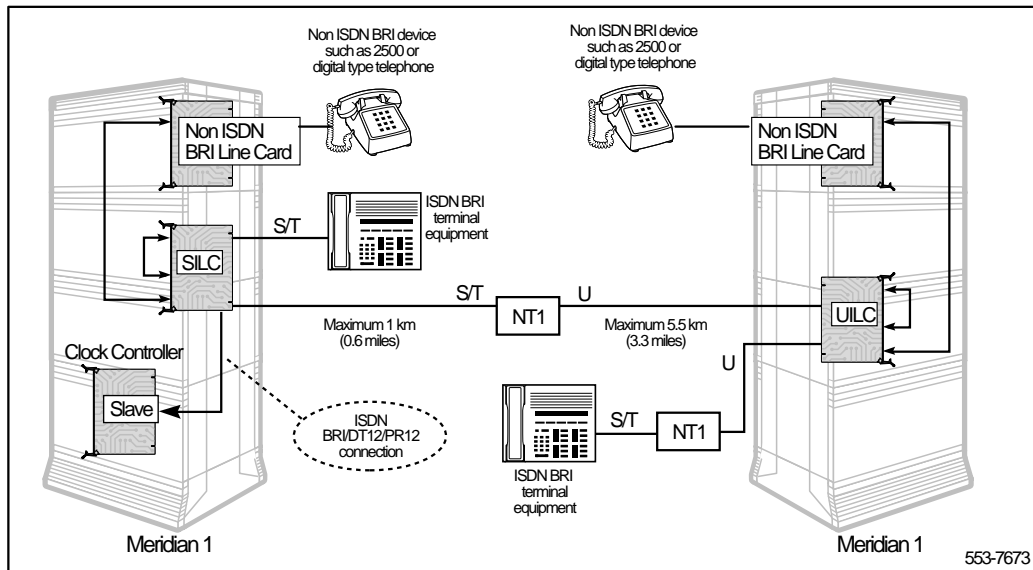

The third configuration (refer to Figure 12), although not recommended because of the lack of protection devices and because of the distance limitation of 1 km (0.6 mile), may establish a MCDN Tie trunk link by connecting two Meridian 1s via a direct line between two back-to-back SILC interfaces.

This configuration would be applied only to multiple buildings on a contiguous property with no exposed cable (with the 1 km limitation between buildings). System clock synchronization may be achieved by having one of the Meridian 1s derive clock reference from the ISDN BRI Tie trunk connection or from other ISDN BRI/PRI/D/TI connections if available. The other Meridian 1 may be allowed to operate in free-run mode or derive the clock source from other ISDN BRI/PRI/D/TI connections if available.

**Figure 12**  
**ISDN BRI Tie trunk connectivity — third configuration, as described above**

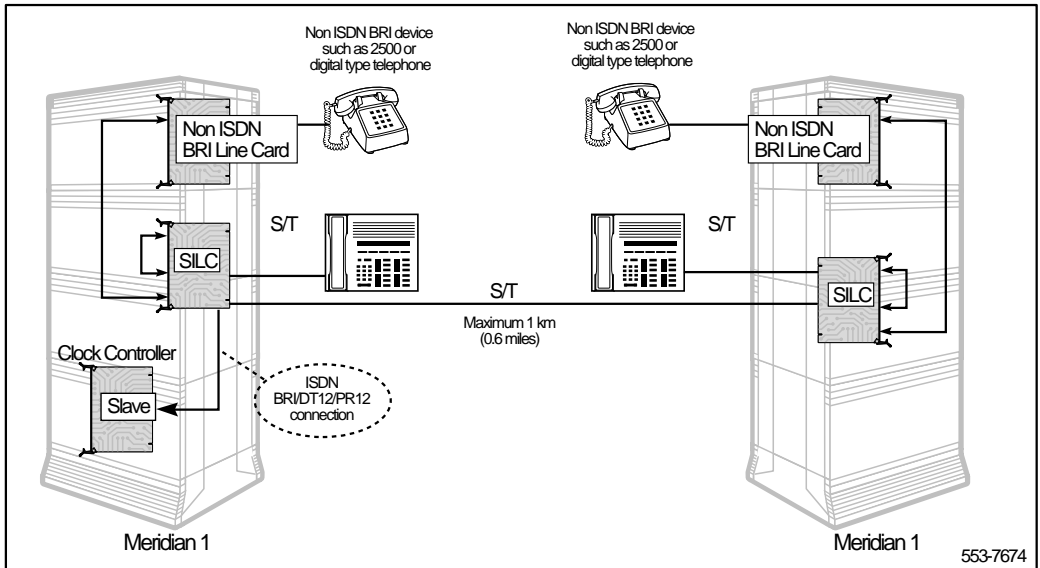

## ISDN BRI QSIG connectivity

The European Computer Manufacturers' Association (ECMA) has defined an ISDN protocol that specifies the Layer 3 signaling requirement for support of circuit switched call control at the "Q" reference point between Private Telecommunications Network Exchanges (PTNXs) connected within a Private Telecommunications Network (PTN).

This protocol has been adopted by the European Telecommunications Standards Institute (ETSI) and the International Standards Institute (ISO). Most of the major global PTNX manufacturers will be supporting ISDN BRI (as well as ISDN PRI) connectivity based on the ISDN QSIG (ETSI and ISO) standard.

QSIG is oriented towards signaling and services that occur between peer-to-peer connectivity, that is, between two PBXs, between two Centrex, or between a PBX and a Centrex. The signaling for services would be exchanged across a “Q” reference point. Figure 13 illustrates an example of QSIG trunk connectivity. For ISDN BRI, the QSIG interface will provide the following capabilities:

- Compliant Multi-vendor PBX/Centrex Private ISDN interworking (connectivity between the Private ISDN PBXs may be via PRI or ISDN BRI trunks)
- ETSI or ISO version of basic call service
- 64 kbps clear data
- Overlap Sending/Receiving
- Channel Negotiation
- In cases where several ISDN BRI trunks (and hence several DSLs) are configured on a route, if Channel Negotiation fails to yield an acceptable channel on any of these DSLs, it is not possible to use another channel on another DSL.
- Calling Line Identification Presentation (CLIP)
- Calling Line Identification Restriction (CLIR)
- Connected Line Identification Presentation (COLP)
- Connected Line Identification Restriction (COLR)
- Flexible Numbering Plan
- Support for Tie trunk call types
- Transit Count information transmitted when ISDN Call Connection Limitation (ICCL) is present (supported for ETSI QSIG only)
- Party Category (partially supported on ETSI QSIG)

**Figure 13**  
**QSIG ISDN BRI trunk connectivity**

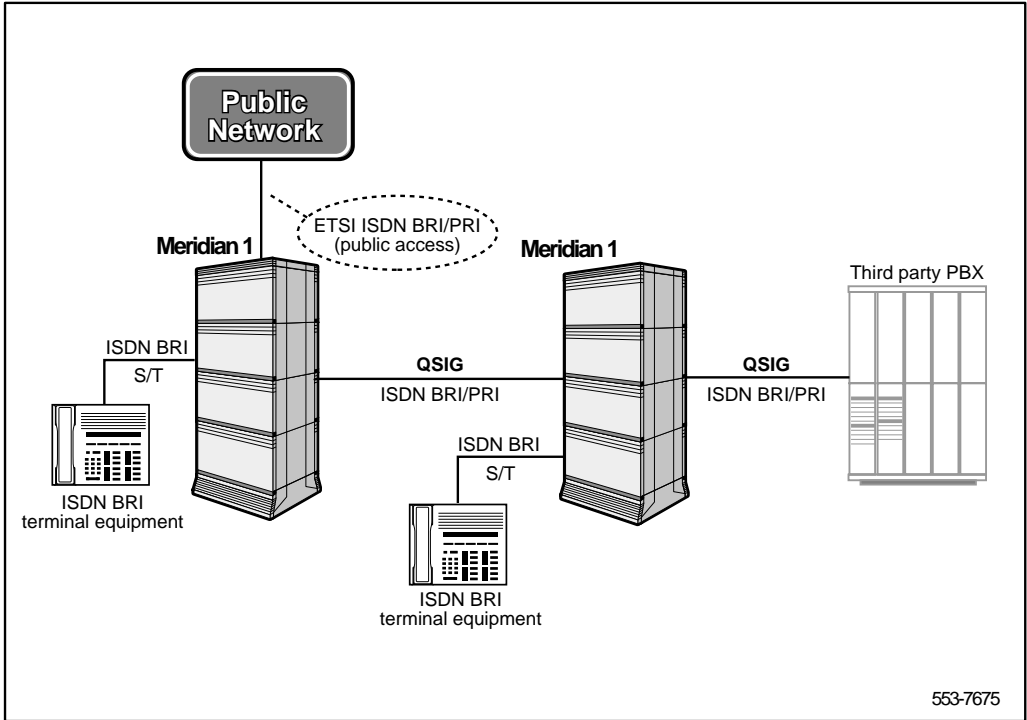





---

# Engineering guidelines

---

## Contents

The following are the topics in this section:

Introduction . . . . .	42
Hardware Requirements . . . . .	42
Line application . . . . .	42
Packet handling . . . . .	45
Trunk application . . . . .	50
Hardware functional descriptions . . . . .	52
Physical capacity . . . . .	67
Physical capacity without the BRSC . . . . .	67
Physical capacity with the BRSC . . . . .	69
Memory capacity . . . . .	69
Protected data store . . . . .	70
Unprotected data store . . . . .	72
ISDN BRI configuration guidelines . . . . .	75
Physical parameters . . . . .	75
Functional parameters . . . . .	80
Transmission characteristics . . . . .	84
SILC DSL line configuration . . . . .	84
SILC DSL trunk configuration . . . . .	96
UILC DSL line configuration . . . . .	96
Terminal addressing and service profile assignment . . . . .	100
ISDN BRI terminal interface specification . . . . .	106
S/T interface specification . . . . .	106
U interface specification . . . . .	107

## Reference list

The following are the references in this section:

- *Upgrade system installation* (553-3001-250)
- *System Engineering* (553-3001-151)
- *ISDN Basic Rate Interface: Installation* (553-3901-200)
- *ISDN Basic Rate Interface: Administration* (553-3901-300)

## Introduction

This chapter describes engineering guidelines that should be used to configure an ISDN BRI system. It describes hardware requirements, system capacity, configuration guidelines, digital subscriber loop transmission characteristics, and interface specifications. For further information about Meridian 1 general engineering guidelines, refer to *System Engineering* (553-3001-151).

## Hardware Requirements

Hardware requirements for ISDN BRI line, packet handling, and trunk applications are as follows (please note that a functional description of each component will follow):

*Note:* The mean time between failures (MTF) is given as appropriate.

### Line application

- **MISP circuit card** — for Options 51C, 61C, 81C, NT6D73; MTF = 29 years. For Option 11C, NTBK22; MTF = 29 years
- **Basic Rate Signaling Concentrator (BRSC) card** (optional) — NT6D72; MTF = 17 years

*Note:* The BRSC is not supported on Option 11C.

- **SILC circuit card** — for Options 11C, 51C, 61C, 81C  
NT6D70AA (-48V North American) MTF = 47.3 years or  
NT6D70BA (-40V International); MTF = 47.3 years

- **UILC circuit card**— for Options 11C, 51C, 61C, 81C NT6D71 (ANSI 2B1Q line encoding);  
MTF = 46.8 years
- **Terminating resistor** — A0378866
- **ISDN BRI terminals**
  - M5317TDX — Meridian 1 set equipped with voice and data transmission options and a hands-free feature; supports B-channel and D-channel packet data.
  - M5209TDcp — Meridian 1 set equipped with voice and data transmission options and a hands-free feature; supports B-channel and D-channel packet data.
  - Other terminals (any other terminal deemed compatible by Nortel Networks)
- **ISDN Terminal Adapter** — M5000TD-1, required if connecting non-BRI terminals to the ISDN BRI line interface
- **Network Termination 1 (NT1)**  
Needed when conversion from a U to an S/T interface is required.

Figure 14 illustrates a basic ISDN BRI line application architecture, configured with a BRSC.

Figure 14  
ISDN BRI line application architecture, configured with a BRSC

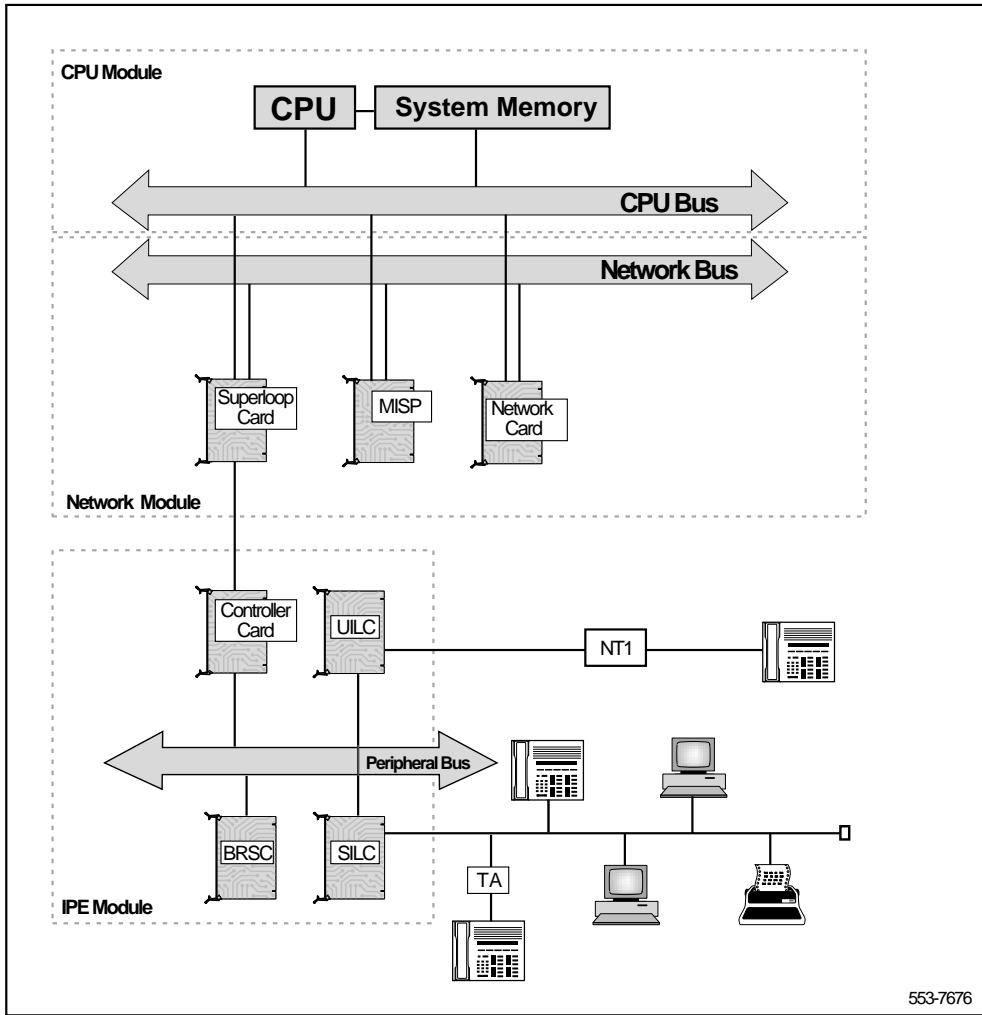

---

## Packet handling

### External packet handler (DPN-100)

- **MISP circuit card** — for Options 51C, 61C, 81C, NT6D73; MTF = 29 years. For Option 11C, NTBK22; MTF = 29 years
- **Basic Rate Signaling Concentrator (BRSC) card** (optional) — NT6D72; MTF = 17 years

*Note:* The BRSC is not supported on Option 11C.

- **SILC circuit card** — for Options 11C, 51C, 61C, 81C, NT6D70AA (-48V North American) or NT6D70BA (-40V International); MTF = 47.3 years
- **UILC circuit card** — for Options 11C, 51C, 61C, 81C, NT6D71 (ANSI 2B1Q line encoding); MTF = 46.8 years
- **Terminating resistor** — A0378866
- **1.5 PRI circuit card** — for Options 51C, 61C, 81C, the QPC720 or the dual-port NT5D12. For Option 11C, the NTAK09.
- **PRI2 circuit card** — for Options 51C, 61C, 81C, the NT8D72, or NT5D97 dual-port DT12/PR12 card or dual-port NTCK43. For Option 11C, the NTAK79, or the NTBK50.
- DPN-100 External Packet Handler
- **ISDN BRI terminals**
  - M5317TDX — Meridian 1 set equipped with voice and data transmission options and a hands-free feature; supports B-channel and D-channel packet data.
  - M5209TDcp — Meridian 1 set equipped with voice and data transmission options and a hands-free feature; supports B-channel and D-channel packet data.
  - Other terminals (any other terminal deemed compatible by Nortel Networks)
- **ISDN Terminal Adapter** — M5000TD-1, required if connecting non-BRI terminals to the ISDN BRI line interface.

- **Network Termination 1 (NT1)**  
Needed when conversion from a U to an S/T interface is required.

Figure 15 illustrates a basic ISDN BRI DPN-100 packet data architecture, with an BRSC.

**Figure 15**  
**A basis ISDN BRI DPN-100 packet data architecture, with a BRSC**

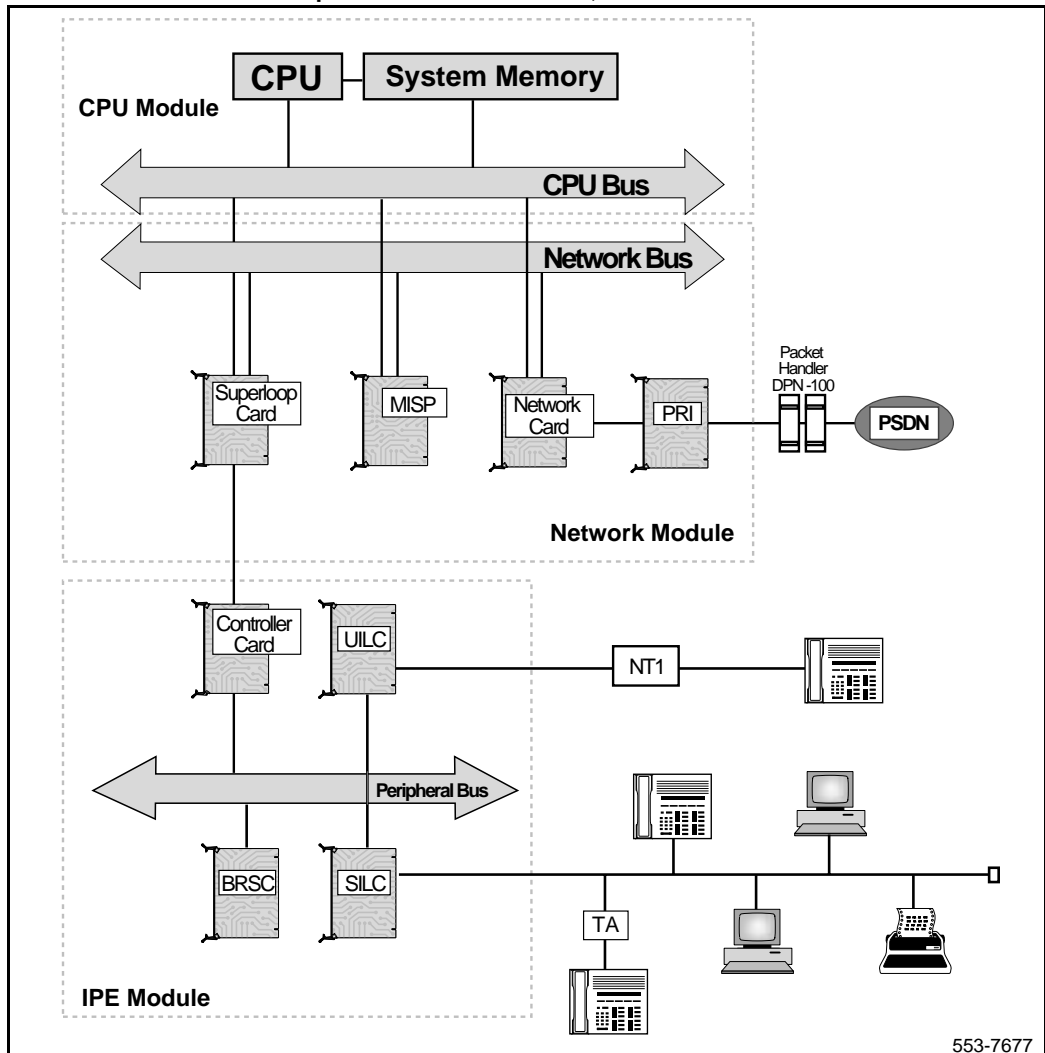

## Meridian 1 Packet Handler (MPH)

*Note:* The MPH is not supported on Option 11C.

- **MISP circuit card** — NT6D73; MTF = 29 years
- **Basic Rate Signaling Concentrator (BRSC) card** (optional) — NT6D72; MTF = 17 years
- **SILC circuit card** — NT6D70AA (-48V North American) or NT6D70BA (-40V International); MTF = 47.3 years
- **UILC circuit card**— NT6D71 (ANSI 2B1Q line encoding); MTF = 46.8 years
- **Terminating resistor** — A0378866
- **1.5 PRI circuit card** — QPC720 or the dual-port NT5D12
- **PRI2 circuit card** — NT8D72, or NT5D97 dual-port DT12/PRI2 card or dual-port NTCK43.

(the use of a PRI card is optional, used if a PRI channel is used to access the PSDN instead of an MCU data module)

*or*

- **Meridian Communication Unit (MCU)** (optional, used if an MCU data module is used to access the PSDN instead of a PRI channel)
- **modem or Digital Interface Unit** (optional, required if an MCU is used)
- **Meridian 1 Packet Handler (MPH)** (downloadable to the MISP)
- **ISDN BRI terminals**
  - M5317TDX — Meridian 1 set equipped with voice and data transmission options and a hands-free feature; supports B-channel and D-channel packet data.
  - M5209TDcp — Meridian 1 set equipped with voice and data transmission options and a hands-free feature; supports B-channel and D-channel packet data.
  - Other terminals (any other terminal deemed compatible by Nortel Networks)

- **ISDN Terminal Adapter** — M5000TD-1, required if connecting non-BRI terminals to the ISDN BRI line interface
- **Network Termination 1 (NT1)**  
Needed when conversion from a U to an S/T interface is required.

Figure 16 illustrates a basic MPH packet data architecture, with a BRSC and an MCU.



Figure 16  
A basis ISDN BRI MPH packet data architecture, with a BRSC and an MCU

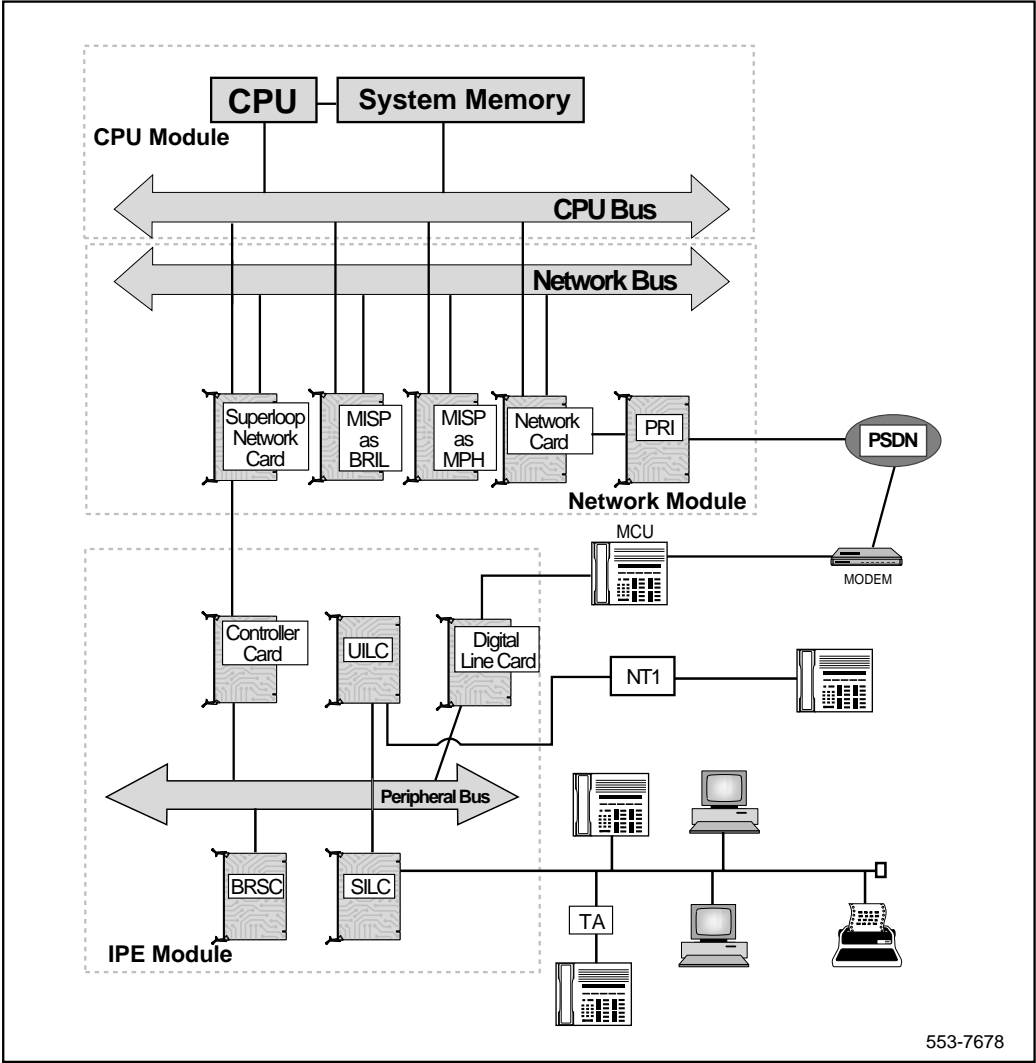

## Trunk application

- **MISP circuit card** — for Options 51C, 61C, 81C, NT6D73; MTF = 29 years. For Option 11C, the NTBK22; MTF = 29 years.
- **SILC circuit card** for Options 11C, 51C, 61C, 81C (for CO/Tie connectivity; IPE card) — NT6D70AA (-48V North American) or NT6D70BA (-40V International); MTF = 47.3 years
- **UILC circuit card** for Options 11C, 51C, 61C, 81C (for Tie connectivity) — NT6D71 (ANSI 2B1Q line encoding); MTF = 46.8 years
- **Terminating resistor** — A0378866
- **Clock Controller** — for Options 51C, 61C, 81C, the QPC775/QPC471 (resides on the CPU shelf; required if the clock source is to be drawn from DSL0 or DSL1 of the SILC; DSL0 can only be configured as the primary source, while DSL1 can only be configured as the secondary source. The CC connects to the SILC clock port via cables)

*Note:* Vintage QPC775E is required for EuroISDN and Numeris VN2 applications.

For Option 11C, the NTAK20AB (Stratum 3 CC daughter board), or the NTAK20BB (Stratum 4 CC daughter board).

- **Clock Controller reference cables** — NTD70, NTND71, NTND72
- **ISDN BRI terminals**
  - M5317TDX — Meridian 1 set equipped with voice and data transmission options and a hands-free feature; supports B-channel and D-channel packet data.
  - M5209TDcp — Meridian 1 set equipped with voice and data transmission options and a hands-free feature; supports B-channel and D-channel packet data.
  - Other terminals (any other terminal deemed compatible by Nortel Networks)
- **ISDN Terminal Adapter** — M5000TD-1, required if connecting non-BRI terminals to the ISDN BRI line interface

- **Network Termination 1 (NT1)** — needed for conversion from a U to an S/T interface

Figure 17 illustrates a basic ISDN BRI trunking architecture, with the Meridian 1 connecting to a CO that supports a Numeris VN3, 1TR6, ETSI NET-3 (EuroISDN), INS NET-64 (including Japan D70), Australia ETSI, or Asia-Pacific protocol.

**Figure 17**  
**A basis ISDN BRI trunking architecture (CO connectivity)**

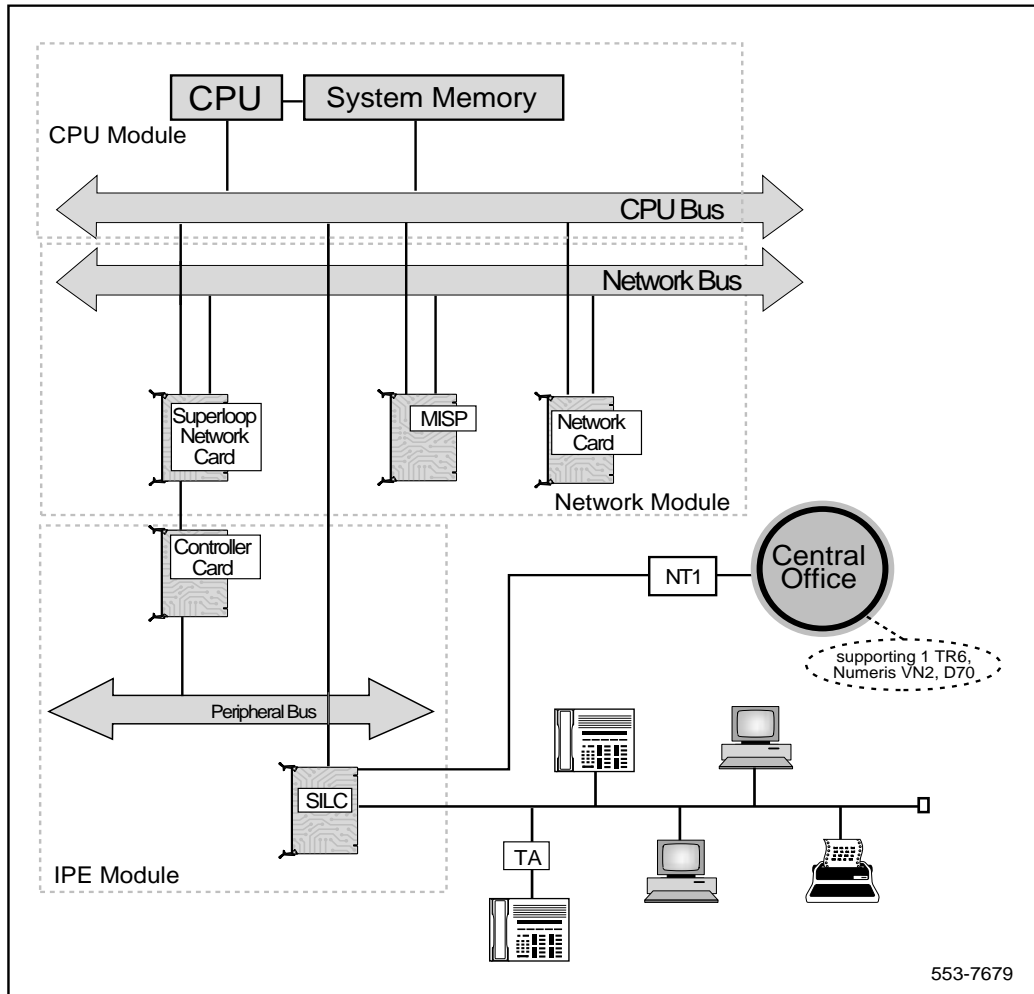

## Hardware functional descriptions

### NT6D72 Basic Rate Signaling Concentrator Card (BRSC)

*Note:* The BRSC is not supported on Option 11C.

The Basic Rate Signaling Concentrator (BRSC) Card can be used to process data link layer signaling messages from all ISDN BRI line cards and send the resulting network layer messages to the MISP. The BRSC also filters out D-channel Packet Switched Data (DSPD) from signaling information and routes it to the packet handler.

With a BRSC configured, fewer MISPs are needed for the same number of DSLs. Each BRSC can support a combination of 15 SILCs/UILCs per IPE Module, with a maximum of eight UILCs.

The BRSC can route the packet data from the line cards to a DPN100, the external packet handler, or to the MPH, the internal packet handler.

### **NTBK22 Multi-Purposes ISDN Signaling Processor (MISP) card, for Option 11C**

The MISP card (NTBK22) is an Option 11C specific card. It performs Data Link (Layer 2) and Network (Layer 3) processing associated with the OSI protocol.

Each MISP can support 4 line cards (UILC or SILC or any combination of the two). Each line card supports 8 DSLs, therefore each MISP supports 32 DSLs. Since each DSL uses two B-channels and one D-channel the MISP supports 64 B-channels and 32 D-channels. If the MISP is carrying packet data, it must dedicate one of its D-channels to communicate with the external packet handler. In this case the MISP support only 31 DSLs. The MISP supports the downloading of ISDN applications from the Option 11C software cartridge. The MISP will be downloaded with the appropriate application code:

- on the first enabling of the MISP card
- when Option 11C Software is upgraded
- when MISP Applications are added/changed

The applications for the MISP are copied from the software cartridge into RAM on the MISP card. Only the new/different applications are downloaded. This information is then copied into the Flash ROM on the MISP for storage. This process requires approximately 10 minutes to complete and is carried out while the MISP pack is operational. The next time the system or MISP card resets, the application is loaded from the MISP Flash ROM provided there are no new or different applications on the software cartridge.

Use the equation below to calculate the number of MISPs required to control SILCs and UILCs.

$$(\text{SILC} + \text{UILCs}) \div 4 = \text{MISPs}$$

If the result is a fraction, round it off to the next highest number.

### **NT6D73 Multi-Purpose ISDN Signaling Processor (MISP), for Options 51C, 61C, 81C**

The NT6D73 MISP is a microprocessor controlled signaling processor that provides a communication interface between the CPU and the peripheral devices. It utilizes the network and the CPU buses to communicate with the CPU, the SILCs, and the UILCs. Both buses are located on the Network Module backplane.

If a BRSC card is not configured in a Meridian 1, each MISP can support 32 D-channels and therefore can support 32 DSLs since each DSL has a D-channel. This is true only if the D-channels are not configured to carry packet data. If they are carrying packet data to the DPN-100, the MISP can support only 31 DSLs.

*Note:* Without a BRSC, one MISP may support up to four SILCs, which results in a maximum of 32 DSLs. Please note that even though every DSL on each SILC may not be defined, you cannot add another SILC (even though you are within the maximum number of 32 DSLs). This is due to the fact the MISP has two nail-ups for each SILC, and each nail-up controls four DSLs in sequential order. Therefore, there is no space in the MISP block to store more than four SILCs.

A BRSC card provides increased capacity, supporting up to 120 DSLs in the same IPE Module. One MISP can serve up to eight BRSCs and two line cards. This increases DSL capacity for the MISP from 32 to 976. This figure is derived as follows:

1 MISP supports 8 BRSCs and 2 line cards (SILC/UILCs)

1 BRSC supports 15 SILC/UILC cards, each having 8 ports:

- total (8 x 15) = 120

1 SILC/UILC card has 8 ports

- total  $(8 \times 120) = 960$   
2 SILC/UILC cards each has 8 ports
- total  $(8 \times 2) = 16$   
Therefore, total number of DSLs =  $960+16 = 976$ .

Each MISP can support directly the following combinations:

- four ISDN BRI line cards without any BRSCs
- three ISDN BRI line cards and one BRSC, or
- two ISDN BRI line cards and a maximum of eight BRSCs

The main functions of the MISP are to:

- communicate with the CPU to report ISDN BRI status and receive downloaded application software and configuration parameters
- execute Open System Interconnect (OSI) data link and network layer protocols
- provides the platform for the Meridian 1 Packet Handler
- process the signaling information received on the D-Channels from DSLs. D-channels may also carry user packet data, which the MISP separates from signaling information and forwards to the external DPN-100 packet handler or internal packet handler (MPH)
- control terminal initialization and addressing
- assign B-channels for switched voice and data transmission
- send call control messages to ISDN BRI links over the D-channel

### **NT6D70AA/NT6D70BA S/T Interface Line card (SILC)**

The SILC cards (NT6D70AA -48V North America, NT6D70BA -40 V International) provide a globally accepted standard interface. The SILC circuit cards support the OSI physical layer (layer 1) protocol.

The SILC provides eight S/T four wire full duplex polarity sensitive interfaces. Each S/T interface provides two B-channels and one D-channel and supports a maximum of eight physical connections that may be configured for ISDN BRI terminals or for CO/Tie trunk connectivity.

For line connectivity, each S/T interface can link up to 20 logical terminals on one DSL. A logical terminal is any terminal that can communicate with the Meridian 1 over a DSL. It may be directly connected to the DSL through its own physical termination or be indirectly connected through a common physical termination.

The length of a DSL depends on the specific terminal configuration and the DSL wire gauge, however, it should not exceed 1 km (0.6 mi.).

The SILC interface uses a 4-conductor cable that provides a differential Transmit and Receive pair for each DSL. The SILC has options to provide a total of 2 Watts of power on the Transmit or Receive leads, or no power at all. When this power is supplied from the S/T interface, the terminal devices must not draw more than the 2 Watts of power. Any power requirements beyond this limit must be locally powered.

A terminating resistor (AO378866) must be placed at the end of each DSL associated with an S/T interface to ensure proper operation.

Other functions of the SILC are:

- support point-to-point and point-to-multi-point DSL terminal connections
- execute instructions received from the MISP to configure and control the S/T interfaces
- provide channel mapping between ISDN BRI format (2B+D) and Meridian 1 system bus format
- enable and disable DSLs
- provide loopback control of DSLs
- for trunking applications, provide a reference clock to the clock controller

### **SILCs required for non-blocking conditions**

Use the equations below to calculate the number of SILCs required to provide interfaces for the S/T type ISDN BRI terminals for non-blocking traffic conditions. To provide a non-blocking traffic condition on a DSL a maximum of 2 B-channel terminals may be connected.

$$\text{SILC B-channel terminals} \div 16 = \text{SILCs}$$



**Note:** A physical terminal that can use two or more B-channels simultaneously such as circuit-switched voice and data, should be counted as two terminals for the purpose of this calculation.

SILC D-channel terminals  $\div$  8 (See Note) = SILCs

**Note:** This assumes one D-channel terminal per DSL, however, you can install more than one such terminal if their combined packet data transmission speeds do not exceed the D-channel throughput of 16 kbps.

If the result is a fraction, round it off to the next highest number. The larger of the two results obtained from the above two equations defines the number of SILCs required.

### **SILCs required in blocking conditions**

If you accept blocking traffic conditions on DSLs, you have the ability to install any combination of B-channel and D-channel terminals on a DSL as long as the total number of physical terminations connecting these terminals to the DSL does not exceed eight and the number of logical terminals does not exceed 20. The greater the number of terminals on a DSL, the greater the traffic blocking.

To calculate the number of SILCs for a combination of terminals on a DSL, follow the equations below:

- Total SILC B-channel terminals  $\div$  (number of B-channel terminals per DSL  $\times$  8) = SILCs
- Total SILC D-channel terminals  $\div$  (number of D-channel terminals per DSL  $\times$  8) = SILCs

If the result is a fraction, round it off to the next highest number. The larger of the two results obtained from the above two equations represents the SILCs for blocking conditions.

	<b>DANGER OF ELECTRIC SHOCK WARNING</b>
	<b>Foreign and surge voltage protection</b>
	In-circuit protection against power line crosses or lightning is not provided on the SILC line card. against power line crosses or lightning is not provided on the SILC line card. When the SILC line card is used in TIE trunk applications in which the cabling is exposed to outside plant conditions, an NT1 module certified for such applications must be used. Check local regulations before providing such service.

### **NT6D71 U Interface Line Card (UILC)**

The NT6D71 UILC card supports the OSI physical layer (layer 1) protocol. The UILC is an ANSI defined standard interface.

The UILC provides eight two-wire full duplex (non polarity sensitive) U interfaces that are used to connect ISDN BRI compatible terminals over DSLs to the Meridian 1. Each U interface provides two B-channels and one D-channel and supports one physical termination. This termination may be to a Network Termination (NT1) or directly to a single U interface terminal. Normally this physical termination is to an NT1, which provides an S/T interface that allows up to 8 physical terminals to be connected.

The length of a U DSL depends on the specific terminal configuration and the DSL wire gauge; typically, however, it should not exceed 5.5 km (3.3 mi). Refer to Table 12 for maximum recommended U DSL length.

The main functions of the UILC are:

- provide eight ISDN U interfaces conforming to ANSI standards
- support point-to-point DSL terminal connections
- provide channel mapping between ISDN BRI format (2B+D) and Meridian 1 bus format

- enable and disable DSLs
- provide loopback control of DSLs

To calculate the number of **NT1s for non-blocking** operation take the larger resulting number from the two equations below:

$$\text{S/T B-channel terminals} \div 2 = \text{NT1s}$$

*Note:* A physical terminal that can use two B-channels simultaneously such as circuit-switched voice and data, should be counted as two terminals for the purpose of this calculation.

S/T D-channel terminals  $\div 6 =$  NT1's. This calculation is application sensitive. Up to 18 logical D-channel terminals may be connected as long as through-put does not exceed 16 kbps on D-channel.

*Note:* The S/T D-channel terminals are divided by 6, since it is assumed that for non-blocking operation, the maximum number of physical connections is 8, and that 2 are used for B-channels.

To calculate the number of **NT1s where blocking is acceptable** to allow maximum number of terminations on a DSL, use the two equations below:

$$\text{S/T B-channel terminals} \div 16 = \text{NT1s}$$

*Note:* This equation assumes that each S/T interface connects eight physical terminals where each physical terminal can use two B-channels simultaneously such as circuit-switched voice and data.

$$\text{S/T D-channel terminals} \div 20 = \text{NT1s (maximum of 20 TEIs per DSL)}$$

In both cases use the larger of the two results. If the result is a fraction, round it off to the next highest number. Add the number of NT1s to the number of true U interface terminals to determine the total number of UILC-supported terminals as follows:

**Total UILC terminals** = Number of NT1s + Number of true U interface terminals

For the sake of this calculation its fair to assume that each true U interface terminal represents an actual physical termination on a U interface type DSL.

To calculate the required number of UILCs to support the total number of UILC terminals (number of NT1s + number of true U interface terminals) in the system, use the following equation:

$$\text{UILCs} = \text{Total UILC terminals} \div 8$$

If the result is a fraction, round it off to the next highest number.

### **NTAK09/NTAK10/NTBK50 PRI card, for Option 11C**

*Note 1:* This item is required for packet data implementation only.

*Note 2:* Vintage NTBK50AA is required for Downloadable D-channel applications. When setting the timers for EuroISDN PRI2 loops in Overlay 73, the following settings are required:

If the Option 11C is connected to a local exchange that supports CRC-4 multiframing, enter CRC-4 in response to the MFF prompt, enter yes in response to the ACRC prompt (to select automatic CRC error reporting), and enter ALT in response to the ALRM prompt (to select alternate alarm mode).

If the Option 11C is connected to a local exchange that does not support CRC-4 multiframing, enter AFF in response to the MFF prompt, and enter ALT in response to the ALRM prompt (to select alternate alarm mode);

In response to the PERS prompt, enter 50 to set the alarm persistence timer to 100ms.

In response to the CLRS prompt, enter 1 to set the clearance persistence timer to 2ms.

ISDN PRI is required for packet data implementation to connect the Option 11C to the external packet handler (DPN-100). B and/or D-channel packet data is transmitted over clear 64 kbps PRI B-channels to the packet handler (a D-channel daughter board is not required). The maximum number is ISDN PRI channels available for communication with the packet handler should not exceed 23 with 1.5 Mb PRI or 30 with 2 Mb PRI.

### **NT8D72/NTCK43/NT5D97 PRI2 card or QPC720/NT5D12 PRI card, for Options 51C, 61C, 81C**

*Note:* This item is required for packet data implementation only.

For 2.0 MBit applications, the NT8D72 ISDN PRI2 card, the dual-port NTCK43 PRI2 card, or the NT5D97 dual-port DTI2/PRI2 card is required for packet data implementation, to connect the Meridian 1 to the external packet handler (DPN-100). For 1.5 MBit applications, the QPC720 ISDN PRI card or the dual-port NT5D12 PRI card is required. If the MPH is used for packet data without the MCU data module, the PRI card is used to provide a PRI channel to access the PSDN.

B and/or D-channel packet data is transmitted over clear 64 kbps PRI/PRI2 B-channels to the packet handler (a D-channel daughter board is not required). The maximum number of ISDN PRI channels available for communication with the packet handler should not exceed 30 with PRI2 or 23 with PRI (D-channel connections are not required for ISDN PRI access).

**Note 1:** Vintage NT8D72BA is required for EuroISDN applications. When setting the timers for EuroISDN PRI2 loops in Overlay 73, the following settings are required:

- If the Meridian 1 is connected to a local exchange that supports CRC-4 multiframing, enter CRC-4 in response to the MFF prompt, enter yes in response to the ACRC prompt (to select automatic CRC error reporting), and enter ALT in response to the ALRM prompt (to select alternate alarm mode).

If the Meridian 1 is connected to a local exchange that does not support CRC-4 multiframing, enter AFF in response to the MFF prompt, and enter ALT in response to the ALRM prompt (to select alternate alarm mode);

- In response to the PERS prompt, enter 50 to set the alarm persistence timer to 100ms;
- In response to the CLRS prompt, enter 1 to set the clearance persistence timer to 2ms.

### **Data Packet Network (DPN-100)**

**Note:** The DPN-100 is required for external packet data implementation only, when the Meridian 1 does not process X.25 packets.

Nortel Networks Data Packet Network (DPN-100) is used as the external packet handler to process the B and/or D-channel packet data sent to it over ISDN PRI B-channels.

## **Meridian 1 Packet Handler**

*Note:* The MPH is required for packet data implementation only. It is not supported on Option 11C.

The MPH provides an alternative to the DPN-100, the external packet handler, for processing packet data. The MPH application resides on the MISP circuit pack. The MPH uses the dedicated MISP as the hardware platform to run the packet handler application. The Meridian 1 supports its administration, utilities and maintenance.

The MPH supports packet data on ISDN BRI B-channels and D-channels. D-channel packet data is routed to the MPH by the MISP line application or BRSC(s). B-channel packet data is routed to the MPH directly through dedicated connections. The MPH routes packet data to the PSDN by means of dedicated channels through either the Primary Rate Interface (PRI) or through a Meridian Communication Unit (MCU) with a synchronous modem. The MPH can support a combination of PRI or MCU connections, to a maximum of three.

The MPH can support three types of calls:

- local calls between packet data terminals connected to the same MPH without PSDN involvement
- calls between packet data terminals on separate MPH applications which must go through the PSDN
- calls to destinations not local to the MPH which are routed to the PSDN

A single MPH provides basic packet data handling functionality for up to 100 D-channels and 19 B-channel packet data terminals.

## **Numbering Plan supported by the MPH**

The MPH supports the CCITT X.121 Numbering Plan, which consists of up to 14 digits to specify the Data Network Address (DNA) of a Data Terminal Equipment (DTE). The DNA consists of a four digit Data Network Identification Code (DNIC) and a one-10 digit National Terminal Number (NTN). The DNIC consists of a three digit Data Country Code (DCC) and a single Network Digit (ND).

In summary, the X.121 DNA is composed as follows:

DNA = DNIC (DCC+ND) + NTN

*where*

DNIC = zxxx (z can be 2-7; the digits 0 and 1 are reserved, and 8 and 9 are used for Telex; x can be 0-9)

NTN = 0000000001-9999999999 (1-10 digits)

**Note:** The DTA may be prefixed by a single digit (0-9), which, while transparent to the MPH, may have a local significance at the PSDN interface (typically used for international calls). This prefix may be entered in response to the PRFX prompt in LD 27, when configuring the MISP for the MPH.

Only one DNIC can be configured for each MPH. Tables of DNAs can be configured and assigned to PSDN interfaces to allow packet data terminals access to the PSDN.

### **The MPH and Permanent Virtual Circuits and Switched Virtual Circuits**

The MPH allows Permanent Virtual Circuits (PVCs) and Switched Virtual Circuits (SVCs) to be established between two local terminals or between a local terminal and a remote destination in the PSDN. The MPH can support 64 simultaneous packet switched data calls.

A Logical Channel Number (LCN) is a numeric identifier at Layer 3. It identifies the particular call (SVC or PVC) where a packet belongs. This allows multiple packet data calls to be established across a single interface.

For a PVC, a permanent logical connection is established by the MPH between the two endpoints. PVCs are mapped by LCNs at each interface. The LCN and the interface are the only identifiers used for routing packets across a PVC. A PVC establishes a permanent call between the two endpoints using the specified LCNs at each interface (without the use of call setup packets). An MPH supports a maximum of four PVCs. Each PVC is defined in the MPH configuration in LD 27. SVCs are established by call request packets originating from an ISDN BRI terminal or the PSDN. The MPH identifies the appropriate destination based on the called DNA in the call request packet.

The MPH dynamically allocates an LCN at the destination interface. The MPH does not support dynamic Layer 2 establishment (that is, terminals using either B-channels or D-channels must have all parameters (Layer 2 and Layer 3) configured and operational to receive and/or transmit calls).

**The MPH and tandem connections**

The MPH allows the Meridian 1 with access to the PSDN, to pass packet data transparently from other Meridian 1 switches in a private network to the PSDN by means of tandem connections. This allows the private network to make optimum use of the number of links to the PSDN. Figure 18 illustrates a tandem connections which involves dedicating a channel on two separate PRI loops on the same switch.

**Figure 18**  
**Tandem connections with the MPH**

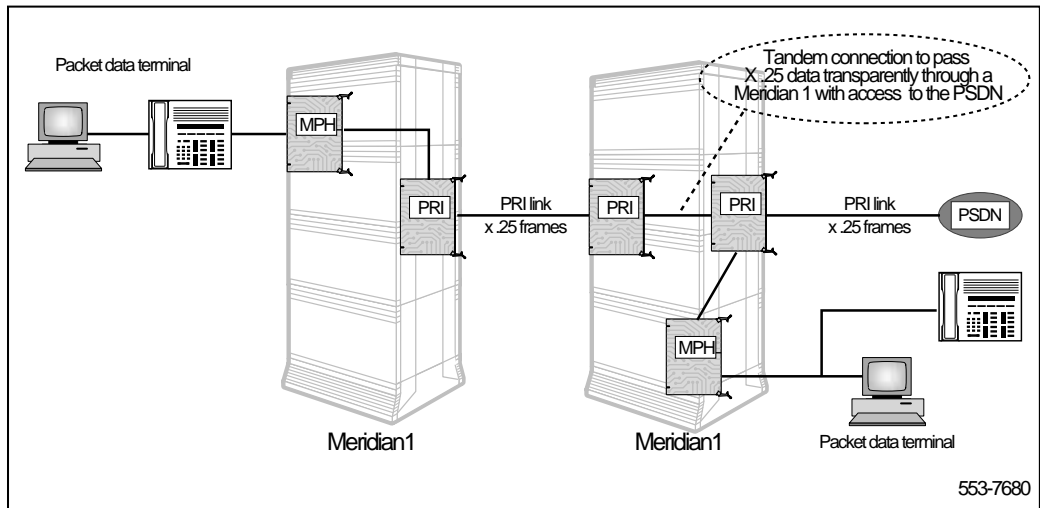



### **Call Detail Recording for MPH**

MPH has two CDR record types: internal and external. The internal packet data call is a data call within an MPH which may cross different customer numbers. The external packet data call is a data call which goes to/comes from the PSDN. This includes calls between two different MPH applications on the same switch. An internal record is generated when internal CDR is equipped on either one or both for the originating data packet terminal or the terminating data packet terminal. If both data packet terminals have internal CDR equipped, then a single record is generated.

### **Characteristics of the MPH application**

The following list summarizes the main characteristics and capabilities of the MPH.

- The MPH application and the ISDN BRI line application must reside on separate MISPs
- There is no routing between MPH applications. The MPH supports routing only between terminals logically attached to it and the PSDN
- The MPH supports the X.121 numbering plan only
- Each MPH application supports a maximum of three links to the PSDN
- There is a maximum of eight D-channel packet data separators, MISPs or BRSCs
- Each MPH application supports a maximum of 100 D-channel terminals
- The MPH can process input from a PRI/PRI2 pack over a 64Kbps or 56Kbps link
- The maximum number of PVCs for each MPH is four
- The maximum simultaneous Packet Switched Data calls for each MPH, including PVCs, is 64
- The maximum B-channel terminations for each MPH application is 19
- Tandem connections apply to PRI links only
- An MPH network interface supports a maximum of four DNA tables
- PVCs have no CDR because there is no call establishing process involved

- The packet size supported is 128 or 256
- The maximum window size is seven

### **Meridian Communication Unit (MCU)**

The MCU is a data module used to interface between the MPH and the PSDN, when an NT8D72 ISDN PRI2 card is not used (the MCU is the only data module that supports the MPH/PSDN interface, due to the proprietary protocol used between the MPH and the MCU that allows X.25 data to pass through the interface).

The MCU requires a nailed-up connection to be established between the MPH and the MCU. The MCU is connected to a modem or Digital Interface Unit (DIU), which in turn is connected to the PSDN via a voice grade or leased line. The communication between the MCU and modem uses data packets framed in HDLC format through a dial-up synchronous modem connection. A Nortel Networks proprietary protocol allows the X.25 data to pass through the MCU and the modem. The maximum data rate supported by any single connection is 64 Kbps.

### **Network Termination 1 (NT1)**

The stand-alone NT1 product, which is typically installed at the user's work area, consists of the following units:

- the NT1 unit
- the optional NT1 power supply
- a mounting plate

The stand-alone NT1 unit is a two-part molded housing 210 mm (8.27 in.) by 108 mm (4.25 in.), its depth tapering from about 50 mm (2 in.) to about 32 mm (1.25 in.). On the unit's housing are four LED status indicators and three connectors.

The bottom of the unit holds four rubber feet for desk-mounting the unit, and four slides that are used to attach the unit to the mounting plate. The unit contains the single NT1 circuit pack assembly.

The stand-alone NT1 is powered by one of two methods:

- 1 The NT1 power supply unit which converts 110 V ac input to provide -48 V dc for the NT1, and optionally for the TEs on the S/T bus.
- 2 A customer-provided -48 V dc supply rated a 2 W minimum for NT1 powering. Additional power may be provided to power the TEs on the S/T bus.

The NT1 power supply unit is virtually identical to the NT1 unit. It is a two-part molded housing of 210 mm (8.27 in.) by 108 mm (4.25 in.), its depth tapering from about 50 mm (2 in.) to about 32 mm (1.25 in.). On the units housing are three connectors, one of which is a captive power cord.

The bottom of the unit holds four rubber feet for desk-mounting the unit, and four slides that are used to attach the unit to the mounting plate. The unit contains a single circuit pack assembly.

Two cables are provided with the NT1 power supply unit:

- a 178 mm (7 in.) cable (A0346581) for connecting between the power supply and the NT1 unit.
- a captive power cord for connection the an ac power outlet.

### **Terminating Resistor**

A terminating resistor (A0378866) is required at the end of each DSL to reduce signal reflection.

## **Physical capacity**

### **Physical capacity without the BRSC**

Without a BRSC, the number of network loops depends on the number of Superloop Network cards in the Network Module(s). Each Superloop Network card supports up to two IPE Modules or 32 conventional time compression multiplexing (TCM) line and trunk cards, or up to 512 ports.

The number of total ports supported by the same system option with ISDN BRI services is smaller and depends on the ratio of conventional ports to ISDN BRI ports.

The reduction of the total number of ports exists because:

- each MISP supports any combination of four SILCs and UILCs
- each SILC and UILC has eight ports

To illustrate these two points, the physical capacity for ISDN BRI systems is calculated for the following two traffic conditions assuming that ISDN BRI ports make up 10% of all the ports in the system:

- non-blocking, where each loop has a voice and data terminal and there is no contention for the B-channels on a DSL
- average traffic load of 6 CCS for voice and 12 CCS for data, where there are more terminals than the system can simultaneously connect

Table 1 shows the number of ISDN BRI ports and the number of TCM ports supported by each system option, assuming 10% ISDN BRI and 90% TCM ports.

**Table 1**  
**Physical capacity without the BRSC**

	Option 51C			Option 61C			Option 81C	
	NB	B		NB	B		NB	B
<b>Capacity</b>	NB	B		NB	B		NB	B
<b>Groups</b>	1/2	1/2		1	1		5	5
<b>Modules</b>	1	1		2	2		10	10
<b>Connections</b>	360	240		720	600		3600	3000
<b>MISPs</b>	1	2		1	4		7	19
<b>Super-loops</b>	3	2		6	5		30	25
<b>DSLs</b>	32	64		32	128		224	608
<b>TCM Loops</b>	133	648		310	1514		1541	7594
<b>Note:</b> * NB = non-blocking, B = blocking								

The Meridian 1 with ISDN BRI reduces the total number of combined ports; however, ISDN BRI DSL ports can connect up to eight physical terminations that may comprise up to 20 logical terminals. This provides greater port capacity than the conventional TCM voice and data ports at the cost of call blocking on the DSL.

## Physical capacity with the BRSC

With the BRSC, the physical capacity of the network also determines ISDN BRI system capacity. The exception is Option 81C where the Meridian 1 CPU Real Time impact is the deciding factor for overall system capacity. ISDN BRI Real Time impact is equivalent to a digital telephone. The capacity for an ISDN BRI switch (all ISDN BRI loops) in terms of the number of DSLs that can be supported is shown in Figure . For Options 51C and 61C, the numbers are the physical capacity of those machines calculated assuming 15% trunking, 25% circuit switched data, and traffic at 6 CCS per voice line.

**Table 2**  
**Physical capacity with the BRSC**

	Option 51C	Option 61C	Option 81C
<b>Blocking capacity DSLs</b>	648	1296	4200

## Memory capacity

The following tables describe the ISDN BRI requirements only. Refer to *Upgrade system installation* (553-3001-250) for complete instruction on how to upgrade your system. Refer to *Memory calculations* for details on memory and capacity.

## Protected data store

Protected data in the main system memory contains terminal identification and service profile data. Table 3 and Table 4 show protected data memory requirements for ISDN BRI line application and trunk application, respectively.

**Table 3**  
**Protected data memory requirements for line application (Part 1 of 2)**

Data	Memory Requirements
Protocol Groups Data	48 words per system maximum
USID Map Data	16 words per DSL maximum
TSP Data	1,072 words per DSL maximum
Other Data	approximately 10 words per system
MISP loop block	37 words
MSDL MISP block	22 words
Socket ID table	49 words
Physical IO block	5 words
IO polling table	1 word per MISP
TN line basic block	21 words
Office Data Administration System (ODAS)	3 words
Class of Service (EFD, HUNT, EHT)	12 words (4x3)
DSL data	14 words (as a non-key function)
LTID data	40 words (as a non-key function)
USID map	16 words

**Table 3**  
**Protected data memory requirements for line application (Part 2 of 2)**

<b>Data</b>	<b>Memory Requirements</b>
Template (base)	15 words
Template (features - LTID, EFD, HUNT, EHT)	1 word each
TSP data block	66 words
ISDN BRI block	7 words for each ISDN BRI DN

**Table 4**  
**Protected data memory requirements for trunk application**

<b>Data</b>	<b>Memory Requirements</b>
Protected Trunk Block (Trunk DSLs use the Protected Trunk Block instead of the Protected BCS Block)	3 words added.
Route Data Block	16 words added for RURC prompt and 1 word added for STAT prompt, for Advice of Charge for Euro ISDN.  6 words added, to store the country for EuroISDN.
ISDN BRI Protocol Data Block	2 words added
Configuration Record	6 words added, to store the country for EuroISDN.
Protected D-channel block	10 words added to store the protocol-specific D-channel information, for the Universal ISDN Protocol Engine (UIEP).
Protected MSDL/MISP block	24 words added, to support the increase from 8 to 32 of the number of supported applications per MSDL/MISP.

## Unprotected data store

Unprotected data in the main system memory is used for *data link* (layer 2) and *network* (layer 3) information message storage during system operation. Table 5 and Table 6 show memory requirements for temporary data storage during system operation for ISDN BRI, for line application and trunk application, respectively.

**Table 5**  
**Unprotected data memory requirements for line application (Part 1 of 2)**

Data	Memory Requirements
MISP input buffer	140 words per system
MISP expedited input buffer	128 words per system
MISP loop block	82 words
MISP output buffer (transmit receive)	260 words
MISP expedited output buffer	512 words
MISP output request buffer	80 words
MSDL MISP block	95 words
Socket ID table	48 words
Meridian 1 expedited receive buffer	128 words
Meridian 1 receive buffer	140 words
Meridian 1 expedited transmit buffer	528 words



**Table 5**  
**Unprotected data memory requirements for line application (Part 2 of 2)**

Data	Memory Requirements
MISP traffic accumulating block	30 words
MISP traffic holding block	30 words
TN line block	32 words (16x2)
Incoming call reference table	33 words
Outgoing call reference table	33 words
Incoming call reference usage map	4 words
Outgoing call reference usage map	4 words
Incoming message call reference table	33 words
Outgoing message call reference table	33 words
DSL data block	3 words

**Table 6**  
**Unprotected data memory requirements for trunk application**  
**(Part 1 of 2)**

Data	Memory Requirements
MISP Call Register Data Block	2 words
Global Variable Data Block	8 words
Trunk Card Block (all ISDN BRI unprotected card block use the Trunk Card Block)	<p>For Advice of Charge For EuroISDN4:</p> <p>For AOC at call set-up:</p> <ul style="list-style-type: none"> <li>- 24 words to store the Start of Time value of the Real Time Clock</li> <li>- type of charging</li> <li>- charged item</li> <li>- charging rate</li> <li>- rate type</li> <li>- currency identifier</li> <li>- currency amount</li> <li>- multiplier</li> <li>- length of time unit</li> <li>- scale of time unit</li> <li>- granularity</li> <li>- scale of granularity</li> </ul> <p>For AOC during the call:no.of words</p> <ul style="list-style-type: none"> <li>- type of charging information</li> <li>- recorded charges</li> <li>- currency identifier</li> <li>- currency amount</li> <li>- multiplier</li> <li>- number of charging unit</li> <li>- billing identification</li> </ul> <p>For AOC at the end of the call:no.of words</p> <ul style="list-style-type: none"> <li>- type of charging information</li> <li>- recorded charges</li> <li>- number of charging unit</li> <li>- currency identifier</li> <li>- currency amount</li> <li>- multiplier</li> <li>- number of charging unit</li> <li>- billing identification</li> </ul>

**Table 6**  
**Unprotected data memory requirements for trunk application**  
**(Part 2 of 2)**

Data	Memory Requirements
Trunk Line Block	6 words
DCH global area, for messaging	1 word
MISP global area, for messaging	2 words
Unprotected MSDL/MISP block	185 words added, to support the increase from 8 to 32 of the number of supported applications per MSDL/MISP.

## ISDN BRI configuration guidelines

Throughout this section, please note the following:

- The BRSC and MPH are not supported on Option 11C
- ISDN BRI trunking is not supported in North America.

Meridian 1 modular design permits flexible engineering. Systems can be tailored to a customer's system size and port type requirements. ISDN BRI line cards can be mixed with conventional TCM line and trunk cards in the same IPE module.

The I/O panels on the IPE modules are the same regardless of the type of line cards installed in the module. Therefore, the external communication cables between Meridian 1 and Main Distribution Frame (MDF) are the same for DSLs and the conventional telephone sets.

### Physical parameters

The physical parameters specific to ISDN BRI are as follows:

- MISP location in the Network module for Options 51C, 61C, 81C, or the main cabinet for Option 11C
- BRSC location in the IPE module
- DSL configuration (line application or trunk access)

### **MISP location in the Network module (Options 51C, 61C, 81C), or main cabinet (Option 11C)**

For Options 51C, 61C, 81C a Network module can contain one or more MISPs. This number is governed by contention for the network card slots and network loop addresses between the MISP and the Superloop Network cards, among other network cards.

Each MISP occupies one network card slot and two network loop addresses. The Superloop Network card also occupies one network card slot, but it requires four network loops, two of its own and two of the adjacent card slot.

Since the MISP uses one network loop for communication with ISDN BRI cards, the MISP must be located in the same Network module as the Superloop Network card. To prevent conflict between the MISP and the Superloop Network card, the MISP should always be installed into a card slot with loop addresses that are not used by a Superloop Network card.

For the Option 11C, MISPs are inserted in the main cabinet in any available slots from 1 through 9.

### **BRSC location in the IPE module**

The BRSC can be located in any IPE module, provided it is in the same module as the ISDN BRI line card it serves.

### **DSL configuration (line application)**

Digital Subscriber Loops configured for line application connect the Meridian 1 to ISDN BRI terminals. A DSL consists of a cable connecting the ISDN BRI DSL port to the Main Distribution Frame (MDF). From the MDF, the loop is cross-connected to the office wiring, which terminates into 8-pin modular jacks (wall outlets). From these outlets, module cables of a maximum length of 10 meters (33 feet) connect to ISDN BRI terminals.

To provide reliable voice and data transmission between Meridian 1 and ISDN BRI terminals, DSLs must be engineered with the following basic considerations in mind:

- number of terminals connected
- loop length (cable type and wire gauge)

- distribution of terminals on a DSL
- type of terminals connected to a DSL

Refer to “Transmission characteristics” in this chapter for a detailed description of the DSL bus configurations and their characteristics. These types are:

- point-to-point SILC DSL (see Figure 20)
- short passive SILC DSL (see Figure 21)
- extended passive SILC DSL (see Figure 22)
- branched passive SILC DSL (see Figure 23)
- point-to-point UILC DSL (see Figure 24)

### ***Loop Length***

Loop lengths for specific configurations are controlled by the differential round-trip time delay to the SILC. A short passive bus uses fixed timing and must maintain the differential round-trip delay between 10 and 14 microseconds. An extended or branched passive loop uses adaptive timing to maintain the differential round-trip delay within two microseconds. A point-to-point passive bus uses adaptive timing with the delay from 10 to 42 microseconds. Please refer to Table 7 for the loss and delay parameters of the various cable types used in determining the S/T DSL configuration limits.

### ***Types of cables***

Some commonly used types of cable with different wire gauges are shown in Table 7 through Table of this section. Please refer to these tables for maximum recommended cable length.

The SILC interface supports a four-wire S/T bus consisting of a transmit pair and a receive pair per DSL. The same wiring polarity must be maintained for all physical terminals on the S/T bus. The SILC supplies up to 2 Watts of power per DSL as an optional terminal power source PS1 by providing -48 volts (ANSI) or -40 volts (international) DC on the transmit pair signal with respect to receive pair. One additional pair of wires may be used in the office wiring to supply power from an auxiliary power source PS2.

The UILC interface supports a two-wire point-to-point loop consisting of a twisted pair engineered for 2B1Q line encoding on the DSL. One physical termination is allowed at the end of the loop. This may be an NT1 device that interfaces with an S/T bus on the subscriber's premises. The U interface is not polarity sensitive. The UILC does not provide power to the terminal.

The cables used to connect the terminals to ISDN BRI cards normally come in one of three wire gauges: 22, 24, and 26 AWG. The larger gauge wire such as 22 AWG has less transmission loss. This means it is actually able to provide a DSL of almost twice the length of the 26 AWG wire for the same loop configuration.

### ***Distribution of terminals***

Distribution of terminals on a DSL depends on the type of loop used and the type of interface connected to the loop. For the SILC interface, use the following rules:

- On a short passive bus, up to eight terminals can be distributed anywhere on the loop.
- On an extended passive bus, the terminals must be clustered at the far end of the loop and no more than 4 terminals should be connected.
- On a branched passive bus, two branches may exist at the end of S/T loop. Up to two terminals per branch can be connected.

**Note:** For each of the bus configurations described above, a terminating resistor (Part number A0378866) must be used to connect the last device.

- Where there is only one terminal connected to the loop in a point-to-point configuration, the terminal must be connected at the end of the loop at the terminating resistor jack.

### ***Type of terminals***

Type of terminal used depends on the customer requirements. The ISDN BRI terminals can be circuit-switched voice or data, B-channel packet data, or D-channel packet data terminals. A DSL can support up to eight physical terminations each linking one or more terminals to the DSL.

The following recommendations should be considered when connecting terminals to DSLs:

- The total number of physical terminations on an S/T DSL may not exceed eight. Up to 20 logical terminals may be connected to an S/T DSL. A logical terminal may be directly connected to the DSL through its own physical termination, or it may be indirectly connected through a common physical termination.

**For non-blocking traffic conditions:** Two B-channel circuit-switched voice or data terminals may be connected on each S/T DSL. More than two B-channel terminals may be connected, however, only two will be able to communicate simultaneously. If more than two terminals are connected this could create a blocking condition where the terminals will contend for available B-channels. Any other terminals connected to this DSL can only be D-channel terminals. You can install more than one D-channel terminal if their combined packet data transmission speeds do not exceed the D-channel throughput of 16 kbps.

**For blocking traffic conditions:** If you accept blocking traffic conditions on DSLs, you have the ability to install any combination of B-channel and D-channel terminals as long as the total number of physical terminations connecting these terminals to the DSL does not exceed eight. These physical terminations may link up to 20 logical terminals. The greater the number of terminals on a DSL, the greater the probability for traffic blocking.

- Only one termination may be connected at the end of a UILC DSL. This termination may be to a Network Termination (NT1) or directly to a single U interface terminal. Normally this physical termination is to an NT1, which provides an S/T interface that allows up to 8 physical terminals to be connected. These terminals communicate to the Meridian 1 through the NT1 and the UILC interface.
- Determine the type of DSL bus configuration you wish to use to connect your terminals keeping in mind the wire type, the length, and the layout of your office wiring

### **DSL configuration (trunk application)**

When configuring DSLs for trunk access the following basic considerations must be kept in mind:

- type of trunk connection to be configured (TIE or CO/DID)

- whether to draw the system reference clock source from the ISDN BRI trunk connection, and the associated clock reference cabling connections
- whether the ISDN BRI trunks are to be configured as the backup trunks for ISDN PRI trunks

**Type of trunk connection** — Digital Subscriber Loops configured for trunk access allows either a TIE trunk connection from either an S/T interface or U interface, or a CO/DID trunk connection from an S/T interface (please refer to the detailed information described earlier in the “ISDN BRI trunk access” section of the “Functional description” chapter).

**System reference clock source** — If the system reference clock source is drawn from the ISDN BRI trunk connection (the Meridian 1 on the USER side), the connection from the SILC line card to the Clock Controller must be from DSL#0 or DSL#1 of the SILC card (please refer to the detailed information described earlier in the “ISDN BRI trunk access” section of the “Functional description” chapter). The clock reference cables have to be connected following the procedures described in *ISDN Basic Rate Interface: Installation* (553-3901-200).

**ISDN BRI trunks as backup for ISDN PRI trunks** — ISDN BRI trunks can be configured as backup trunks for ISDN PRI trunks, through ESN Route Selection or Route Hunting. As well, an ISDN BRI clock source can be configured as a secondary clock reference for an existing ISDN DTI/PRI clock source.

## Functional parameters

Functional parameters must be considered during ISDN BRI configuration procedures. These procedures are used to create an ISDN BRI database and to configure ISDN BRI functions and features when administering the system. These functional parameters apply to:

- ISDN BRI database generation
- DSL addressing



### ISDN BRI database generation

When installing ISDN BRI in the system for the first time, configure these components in the order listed below. See *ISDN Basic Rate Interface: Administration* (553-3901-300) for detailed procedures on configuring ISDN BRI.

When changing existing ISDN BRI service, following this order is unnecessary. However, be aware of the relationship of one component to another and whether changing one component necessitates changing other components.

Configurations for an ISDN BRI line application are:

- LAPD protocol group
- Multi-purpose ISDN Signaling Processor (MISP)
- Basic Rate Signaling Concentrator (BRSC) (optional)
- S/T line card/U line card (optional)
- Digital subscriber loop (DSL)
- Terminal Service Profile (TSP) on DSL
- Terminals (for example, M5317TDX, M5209TDcp)
- Traffic (LD 02) (optional)

To add an MPH to a Meridian 1 with an existing ISDN BRI configuration, perform the following configurations in the order shown. Use LD 27 except where noted otherwise:

- Configure the LAPD protocol group
- Configure the LAPB protocol group
- Configure the X.25 packet protocol group
- Configure the DNA table associated with the MPH network interface
- Configure the ISDN Primary Rate Interface (PRI) for packet data:
  - the ISDN PRI loop (LD 17).
  - the ISDN customer (LD 15).

- the tie trunk route for packet data (LD 16).
- the tie trunk for packet data (LD 14).

OR, if an MCU is used instead of a PRI pack:

- Configure
  - the tie trunk route for packet data (LD 16).
  - the tie trunk for packet data (LD 14).
  - the Meridian Communication Unit (MCU) (LD 11).
- Perform changes at a centralized MPH location or at a remote location to enable tandem connections (optional) (LD 14).
- Configure a Multi-purpose ISDN Signaling Processor (MISP) for an MPH.
- Disable the MISP and modify the MISP for line cards or BRSCs to support D-channel packet data.
- Modify the TSP for D-channel packet data.
- Modify the DSL for B-channel packet data and define new TSP.
- Configure Permanent Virtual Circuits (PVCs) (optional)
- Change terminal configurations (M5317TDX, M5209TDcp, M5000TD-1).
- Configure Customer Data Record (CDR) (LD 15 and LD 27). (optional)

To add an external packet handler (DPN-100) to a Meridian 1 with an existing ISDN BRI configuration, configure the following steps in the order shown. Use LD 27 except where noted otherwise:

- LAPD protocol group
- Packet data transmission:
  - the ISDN PRI loop (LD 17)
  - the ISDN customer (LD 15)
  - the tie trunk route for packet data (LD 16)
  - the tie trunk for packet data (LD 14)

- Multi-purpose ISDN Signaling Processor (MISP)
- Basic Rate Signaling Concentrator (BRSC) Card (optional)
- S/T Interface Line Card (SILC)/U Interface Line Card (UILC) (optional)
- Digital subscriber loop (DSL)
- Terminal Service Profile (TSP) on DSL
- Terminals (for example, M5317TDX, M5209TDcp)

Configurations for an ISDN BRI trunk application are:

- ISDN customer (LD 15)
- Trunk pad tables (LD 73) (optional)

*Note:* The digital pad provides gain or attenuation values to condition the level of the digitized transmission signal according to the network loss plan. This determines transmission levels for the B-channel circuit-switched voice calls.

- LAPD Protocol Group
- ISDN BRI trunk route data block (LD 16)
- MISP
- SILC (for CO/Tie connectivity) and/or UILC (for Tie connectivity)
- Trunk DSL
- If the SILC clock is configured, enter the ISDN BRI trunk clock reference (LD 73)

### **DSL addressing**

ISDN BRI DSL addressing corresponds to standard TN addressing. A DSL address is uniquely defined as TN (l, s, c, dsl# for Options 51C, 61C, 81C, or c, dsl# for Option 11C), where, for Options 51C, 61C, 81C:

- **l** is the number of the network superloop by which it is controlled
- **s** is the number of the IPE module (shelf number) where it is located
- **c** is the card slot position of the SILC/UILC in the module
- **dsl#** is the port number on the card

For Option 11C:

- **c** is the card slot position of the SILC/UILC
- **dsl#** is the dsl number

## Transmission characteristics

ISDN BRI provides two different types of interfaces: the S/T interface provided by the SILC and the U interface provided by the UILC. Each interface has unique physical and transmission characteristics and requires different considerations when configuring DSLs for lines or trunks.

### SILC DSL line configuration

The SILC supports both point-to-point and point-to-multipoint transmission. The maximum DSL length must not exceed 1 km (3,280 ft); however, the actual length depends on the cable wire gauge, the number of terminals connected to the loop, and the differential round-trip time delay limits.

When you are configuring DSLs for lines, follow these basic rules:

- maintain wiring polarity for both the transmit and receive pairs
- use a maximum of 10 m (33 ft) modular cable to connect each ISDN BRI terminal to the DSL
- keep the length of the cable stub (distance between the RJ-45 receptacle and the DSL cable) to less than 1 m (3.3 ft)
- do not allow bridge taps or split pairs on the DSL and make sure that the differential pairs (Tx-/Tx+ and Rx-/Rx+), each consist of a twisted pair along the entire length of the DSL
- make sure ISDN BRI terminals powered through the DSL do not exceed the total power of 2 Watts
- connect a maximum of two ISDN BRI terminals requiring B-channel transmission or one terminal using both circuit-switched voice and data to each DSL for a non-blocking configuration. For maximum concentration per DSL, connect up to 8 physical BRI terminals, and up to 20 logical terminals to use two B-channels and the 16 kbps capacity of the D-channel.

- Select the appropriate Network Terminal line sampling mode (NTFS for fixed and NTAS for adaptive) when configuring the DSL in LD 27.

NT Mode Fixed Sampling (NTFS) may be selected when the device is in an NT on a passive bus wiring configuration up to approximately 200 meters in length (depending on cable type). In this mode, multiple terminals (up to eight) may be connected anywhere along the passive bus.

NT Mode, Adaptive Sampling (NTAS) should be selected when the device is in an NT on any wiring configuration up to the maximum specified length for operation. Multiple terminals, if required, must be grouped within approximately 100 meters of each other (depending on cable type).

- place the terminating resistor (A0378866) at the end of the loop, depending on the configuration (refer to Figure 19).

Figure 19 shows a wiring example of an SILC DSL with multiple physical terminations and the terminating resistor at the end of the loop. An SILC DSL consists of a six-wire twisted pair cable, but only four wires carry the signal and two wires provide conduit for an auxiliary power source. This external power source can be used when the total power consumption exceeds 2 Watts on each DSL. In this case the terminals need to be configured to use the auxiliary power source (PS2) or other auxiliary power supplies as part of their product packages.

**Figure 19**  
**S/T digital subscriber loop wiring example for ISDN BRI lines**

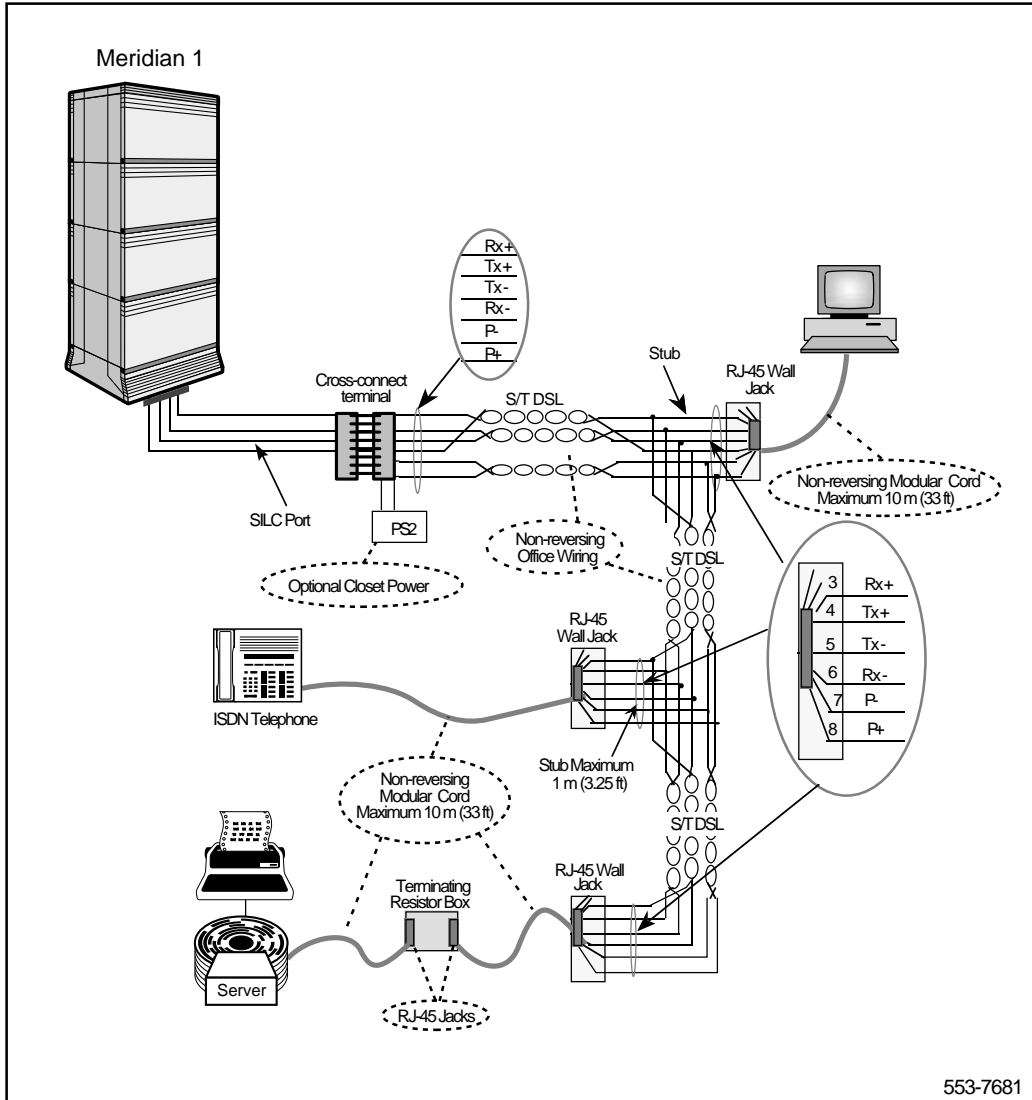

### Cable characteristics

Table 7 lists the parameters of the various cable types used in determining the S/T DSL configuration limits. The cables listed are those used for telephony wiring applications, and the characteristics listed are for Nortel Networks cable at 96 kHz and 20°C (68° F).

**Table 7**  
**Cable types and characteristics**

Cable type	Gauge AWG	Loss dB/km (dB/kft.)	Delay µs/km (µs/kft.)
Outside PIC	22	1.6 (5.4)	1.7 ( 5.5)
Outside pulp	22	1.8 (6.0)	1.6 (5.3)
Outside PIC	24	2.3 (7.6)	1.7 (5.6)
Outside pulp	24	2.5 (8.2)	1.7 (5.5)
Outside PIC	26	3.3 (11.0)	1.8 (5.9)
Outside pulp	26	3.3 (11.0)	1.7 (5.7)
Inside riser	22	1.6 (5.2)	1.6 (5.2)
Inside riser	24	2.3 (7.5)	1.7( 5.6)
Inside riser	26	3.2 (10.5)	1.8 (5.9)
Inside Z station (FT1)	22	1.6 (5.2)	1.8 (5.9)
Inside Z station (FT4)	22	2.0 (6.6 )	2.0 (6.6)
Inside type D (3 and 4 pair)	24	2.6 (8.5 )	1.9 (6.2)
Inside type D (25 pair)	24	2.9 (9.5 )	2.0 (6.6)

The following examples show some typical SILC DSL configurations. These are:

- point-to-point DSL
- short passive DSL

- extended passive DSL
- branched passive DSL

### Point-to-point SILC DSL

This configuration is shown in Figure 20. It represents the simplest type of bus configuration.

Figure 20  
Point-to-point DSL

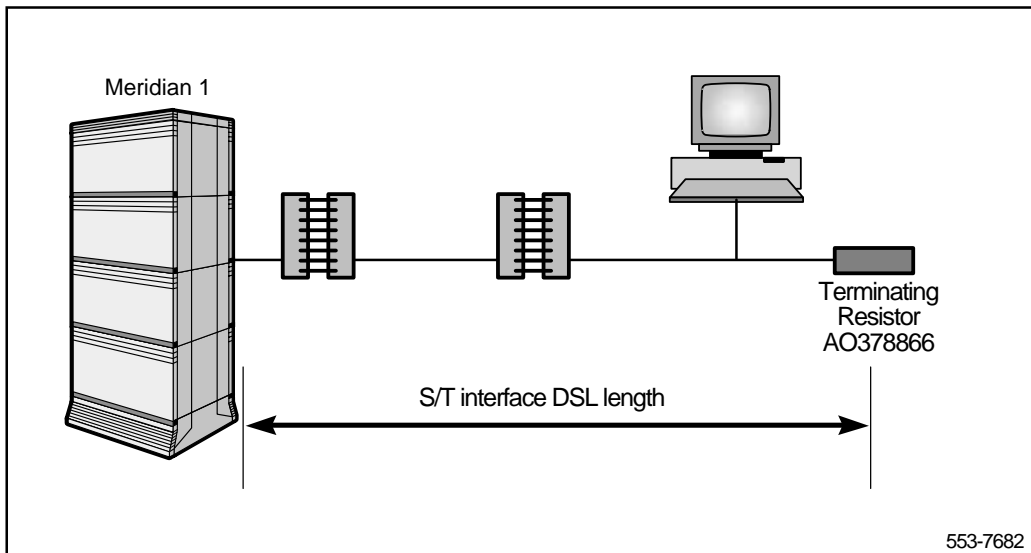

The Point-to-Point bus provides the longest SILC DSL length.  
Recommended rules:

- Configure the DSL as adaptive mode through overlay 27 (MODE = NTAS)
- Use a terminating resistor (A0378866) at the end of the DSL.
- Connect only one terminal.
- Cable loss must not exceed 6 dB.



Maximum DSL length depends on the cable type and wire gauge. For a point-to-point bus, the SILC DSL length is as shown in Table 8.

**Table 8**  
**Cable types and point-to-point DSL lengths**

<b>Cable type</b>	<b>Gauge AWG</b>	<b>Maximum DSL length m (ft.)</b>
Outside PIC	22	1110 (3640)
Outside PIC	24	790 (2590)
Outside PIC	26	540 (1770)
Outside pulp	22	1000 (3280)
Outside pulp	24	730 (2390)
Outside pulp	26	540 (1770)
Inside riser	22	1150 (3770)
Inside riser	24	800 (2620)
Inside riser	26	570 (1870)
Inside Z station (FT1)	22	1150 (3770)
Inside Z station (FT4)	22	910 (2980)
Inside type D (3 and 4 pair)	24	700 (2300)
Inside type D (25 pair)	24	630 (2070)

### **Short passive SILC DSL**

This configuration is shown in Figure 21.

**Figure 21**  
**Short passive SILC DSL**

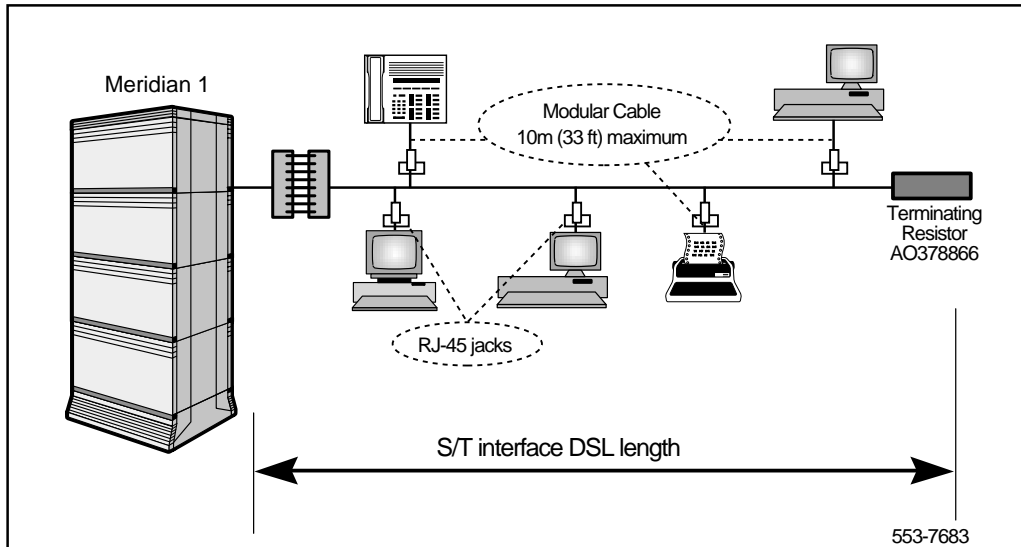

In the short passive SILC DSL configuration the Meridian 1 and terminals may be located anywhere along the SILC DSL. This configuration has the shortest length, but the maximum number of terminals are allowed with no restrictions on the location of the Meridian 1 and the terminals.

Recommended rules:

- Configure the DSL as fixed timing mode through overlay 27 (MODE = NTFS).
- A maximum of eight physical terminals may be connected.
- Use a 100  $\frac{3}{4}$  terminating resistor (A0378866) at the end of the DSL.
- Terminate both ends of the DSL if the NT is not located at the end of the DSL. In this case the distance between the Meridian 1 and the SILC DSL should not exceed 30 ft (9 m).
- The maximum round trip delay for the selected DSL cable is 2  $\mu$ s.

Maximum DSL length depends on the cable type and wire gauge. For a short passive SILC DSL, the length is as shown in Table 9.

**Table 9**  
**Cable types and short passive SILC DSL lengths**

<b>Cable type</b>	<b>Gauge AWG</b>	<b>Maximum DSL length m (ft.)</b>
Outside PIC	22	170 (560)
Outside PIC	24	165 (540)
Outside PIC	26	155 (510)
Outside pulp	22	170 (560)
Outside pulp	24	170 (560)
Outside pulp	26	160 (520)
Inside riser	22	180 (590)
Inside riser	24	165 (540)
Inside riser	26	150 (490)
Inside Z station (FT1)	22	150 (490)
Inside Z station (FT4)	22	140 (460)
Inside type D (3 and 4 pair)	24	150 (490)
Inside type D (25 pair)	24	145 (480)

### **Extended passive SILC DSL**

This bus configuration is shown in Figure 22.

**Figure 22**  
**Extended passive SILC DSL**

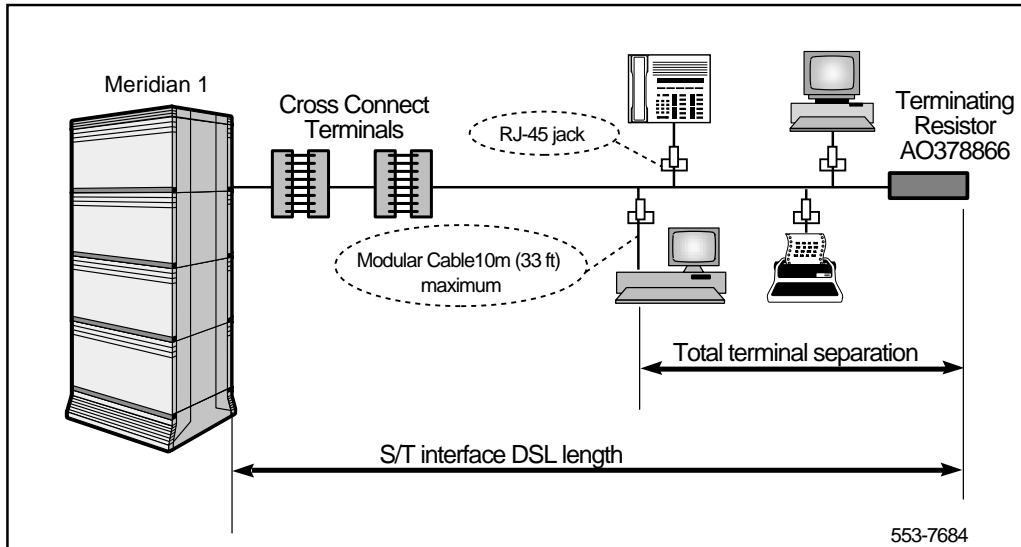

The extended passive bus is designed to allow up to four terminals to be located a long distance from the SILC. The length of the SILC DSL and the separation between each terminal are the significant factors in this configuration.

Recommended rules:

- Configure the DSL in adaptive mode through overlay 27 (MODE = NTAS).
- Use a 100  $\frac{3}{4}$  terminating resistor (A0378866) at the end of the SILC DSL.
- Configure no more than four terminals.
- The cable loss must not exceed 3.8 dB.

The maximum SILC DSL length and separation between terminals is given in Table . Configure the first terminal at the end of the terminated SILC DSL, then calculate the distance from the farthest to the nearest terminal.

For every terminal (less than four) not configured, you may add 15 ft (5 m) to the distance of total terminal separation.

**Table 10**  
**Cable types and extended passive SILC DSL lengths**

<b>Cable type</b>	<b>Gauge AWG</b>	<b>Maximum DSL length m (ft.)</b>	<b>Total terminal separation m (ft.)</b>
Outside PIC	22	700 (2300)	40 (130)
Outside PIC	24	500 (1640)	40 (130)
Outside PIC	26	340 (1110)	36 (120)
Outside pulp	22	630 (2070)	42 (140)
Outside pulp	24	460 (1510)	40 (130)
Outside pulp	26	340 (1110)	36 (120)
Inside riser	22	730 (2390)	42 (140)
Inside riser	24	500 (1640)	38 (125)
Inside riser	26	360 (1180)	35 (115)
Inside Z station (FT1)	22	730 (2390)	35 (115)
Inside Z station (FT4)	22	570 (1870)	33 (110)
Inside type D (3 and 4 pair)	24	440 (1443)	35 (115)
Inside type D (25 pair)	24	400 (1310)	35 (115)

### **Branched passive SILC DSL**

This bus configuration is shown in Figure 23.

**Figure 23**  
**Branched passive SILC DSL**

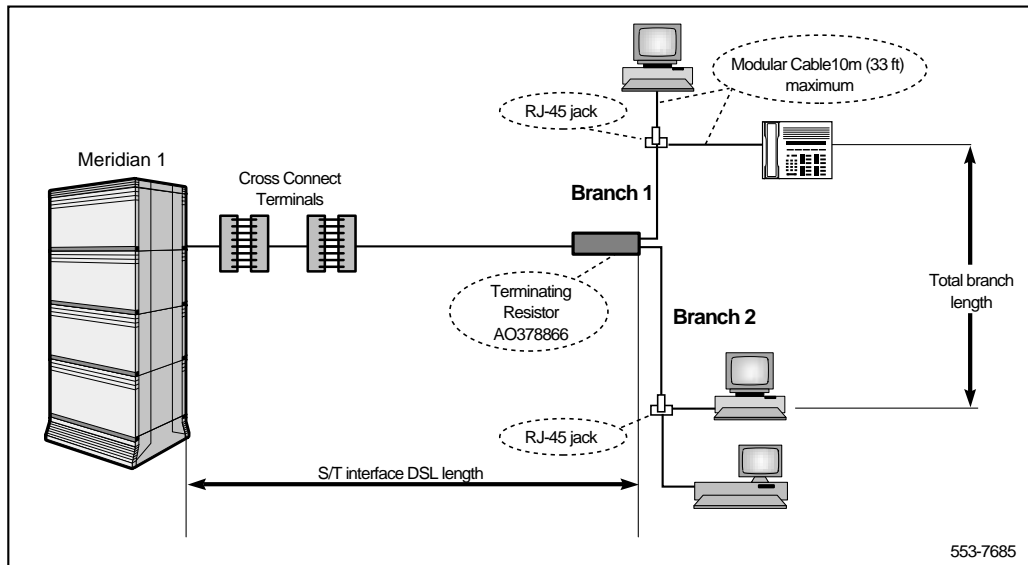

The branched passive bus configuration uses the existing building wiring where the SILC DSL is terminated in a telephone wiring closet. The significant factors in this configuration are the maximum SILC DSL length, the total length of the two branches, and the difference between two branch lengths.

Recommended rules:

- Configure the DSL as adaptive mode through overlay 27 (MODE = NTAS).
- Configure no more than four terminals.
- Configure no more than two terminals per branch.
- Use a 100  $\frac{3}{4}$  terminating resistor at the end of the SILC DSL.
- The cable loss must not exceed 3.8 dB.

Maximum SILC DSL length depends on the cable type and wire gauge. For a branched passive bus, the DSL length is typically:

- 1,919 ft (585 m) for Inside Z station type cable 22 AWG
- 1,197 ft (365 m) for Inside type D cable 24 AWG
- 1,033 ft (315 m) for Inside riser type cable 26 AWG

Calculate the length of the SILC DSL, the sum of the branches, and difference in the length of the branches. Refer to Table for maximum allowable limits.

**Table 11**  
**Cable types and branched passive SILC DSL lengths**

<b>Cable type</b>	<b>Gauge AWG</b>	<b>Maximum DSL length m (ft.)</b>	<b>Branched lengths m (ft.)</b>
Outside PIC	22	340 (1115)	105 (345)
Outside PIC	24	270 (885)	105 (345)
Outside PIC	26	215 (705)	100 (330)
Outside pulp	22	315 (1030)	110 (360)
Outside pulp	24	255 (835)	105 (345)
Outside pulp	26	215 (705)	95 (310)
Inside riser	22	350 (1150)	110 (360)
Inside riser	24	270 (885)	105 (345)
Inside riser	26	220 (720)	100 (330)
Inside Z station (FT1)	22	350 (1150)	100 (330)
Inside Z station (FT4)	22	295 (965)	95 (310)
Inside type D (3 and 4 pair)	24	250 (820)	100 (330)
Inside type D (25 pair)	24	770 (235)	95 (310)

## SILC DSL trunk configuration

When you are configuring trunk DSLs, follow these basic rules:

- spread the two B-channels out as members of the Route Data Block, so that if a trunk DSL is out of service, the search for an idle trunk will not be impaired.
- do not exceed the maximum loop length of 1km (0.6 mi) for the S/T interface.
- if the system reference clock source is to be drawn from the SILC, the connection to the clock controller can only be from DSL#0 and DSL#1 of the SILC card. DSL#0 may only be configured as the primary clock reference and DSL#1 as the secondary clock reference. Also, ensure that the proper cable connections are made between the SILC and the clock controller, following the procedures described in *ISDN Basic Rate Interface: Installation* (553-3901-200).

## UILC DSL line configuration

The UILC supports only point-to-point transmission. The maximum length of the U interface DSL is determined by the maximum loop loss, but typically should not exceed 5.5 km (3.3 mi). Table 12 gives the maximum recommended U DSL length. The maximum loss is 46 dB @ 40 kHz.

However, to meet the mandatory bit error rate performance of  $10^{-7}$  or better in all cases, a maximum limit of 40 dB cable loss is recommended.

**Note:** This interface is designed to utilize most of the existing non-loaded twisted pair wiring in North America. Not all the twisted pair cables are suitable for ISDN BRI application. Before you use a section of this cable, you must verify its suitability by performing the following tests:

- determine the type and length of the cable, and the total signal loss of the DSL (calculated using Table 13)
- determine total signal loss contributed by the bridge taps on the DSL (1.7 db/kft(km) and up to 5.1 db for each bridge tap length)
- verify that there are no consistent or random noise sources that may affect the transmission quality (i.e., using a Bit Error Rate tester, the result should be better than  $10^{-7}$  error rate for at least 30 minutes)



**Note:** All calculated losses above should total less than 40dB @ 40 kHz (BER  $\leq 10^{-7}$ ).

- determine the outlet pinout at the terminal location

Figure 24 shows a typical U interface DSL with an NT1 terminating the DSL and providing an S/T interface to an ISDN BRI terminal.

**Figure 24**  
**Point-to-Point UILC DSL**

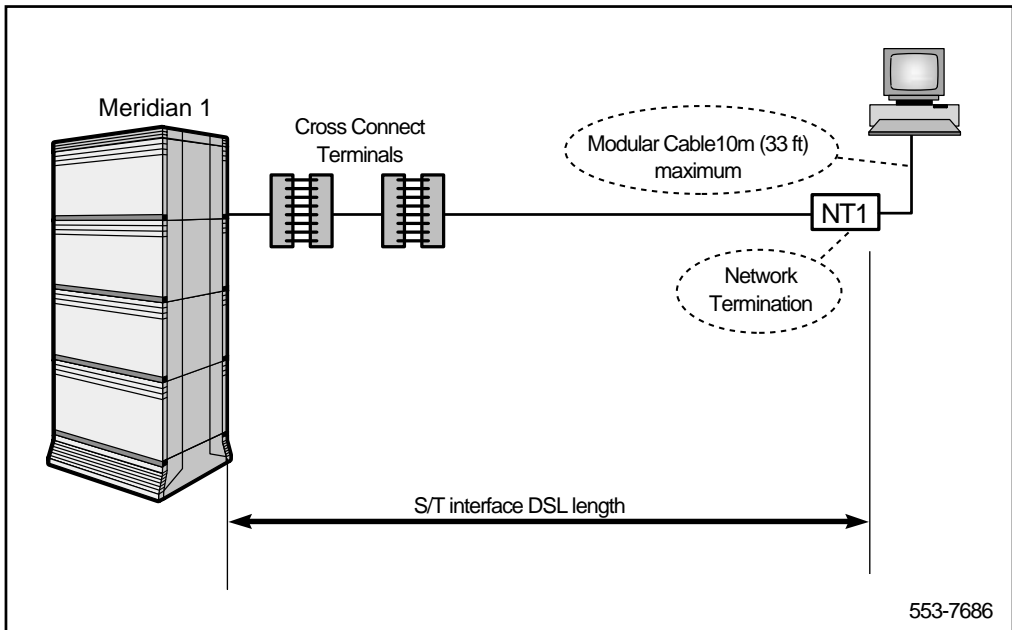

Table 12 lists the maximum recommended loop length which should be considered in U interface DSL installations without any bridge taps (refer to Table 12 for a guideline for calculating DSL loop loss for U interface DSL installations with bridge taps).

**Table 12**  
**Maximum recommended U DSL length**

Cable gauge AWG	Maximum recommended length km (kft.)
26	4.40 (14.5)
24	6.55 (21.5)
22	8.80 (29.0)
mix	5.50 (18.0)

Table 13 is recommended as a guideline for calculating selected U interface DSL loop loss. Use the **Length km (kft.)** and **Loss dB** columns to record your calculations. Select the corresponding loss (dB/kft) based on the type of cable used and multiply by the cable length. After calculating all the losses due to the DSL used, calculate losses due to bridge taps. For any bridge tap with length exceeding 3 kft, only add 5.1 dB. Add all the losses due to the DSL and due to bridge taps, and record your calculations. The total loss should not exceed the recommended maximum loss of 40 dB.

*Note:* The bridge taps are not terminated and are left unused. A complete knowledge about the characteristics of the DSL selected is recommended. Keep the DSL as simple and as short as possible to obtain maximum performance .

**Table 13**  
**UDSL cable calculations (Part 1 of 2)**

Item	Gauge AWG	Insulation type	Loss dB/km (dB/kft.)	Length km (kft.)	Loss dB
1	19	PIC	1.0 (3.3)		
2	19	pulp	1.1 (3.6)		
3	22	PIC	1.4 (4.6)		
4	22	PIC	1.5 (4.9)		

**Table 13**  
**UDSL cable calculations (Part 2 of 2)**

Item	Gauge AWG	Insulation type	Loss dB/km (dB/kft.)	Length km (kft.)	Loss dB
5	24	PIC	1.8 (5.9)		
6	24	pulp	1.9 (6.3)		
7	26	PIC or pulp	2.8 (9.2)		
8	Customer premises wiring		1.8 (5.9)		
9	Local exchange wiring		2.8 (9.2)		
10	bridge tap 1				
11	bridge tap 2				
12	bridge tap 3				
13	bridge tap 4				
14	bridge tap 5				
15	bridge tap 6				
Total loss in dB (add items 1 through 15)					
Recommended maximum loss = 40 dB					

Figure 25 shows a DSL extension where the U interface is used to extend the loop to an NT1 and from the NT1 it shows an S/T interface connecting two ISDN BRI terminals.

**Figure 25**  
**UILC DSL used as an extension for an S/T interface loop**

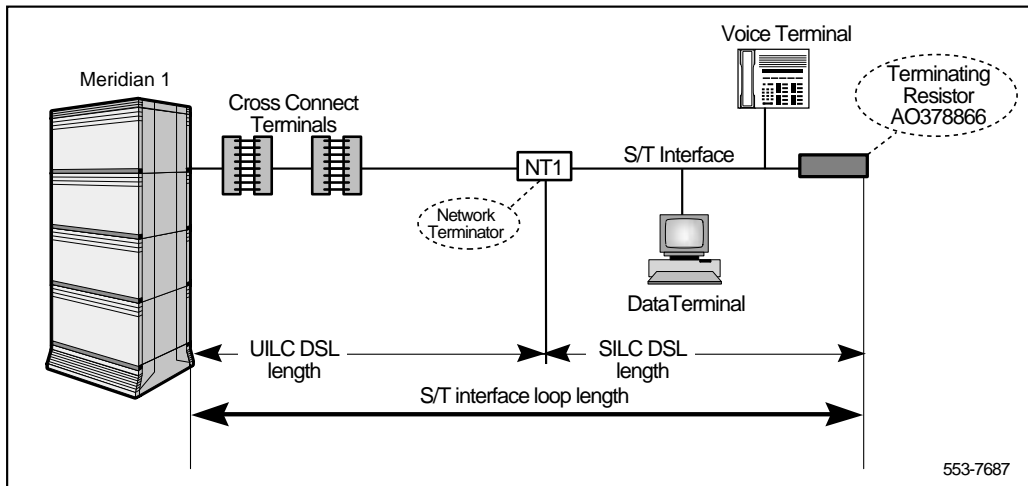

## Terminal addressing and service profile assignment

Terminal Service Profiles (TSPs) are service profile specifications stored in the database that can be associated with various terminals during terminal initialization and that define the terminal DN, class of service, call restriction levels, and other service and feature attributes. ISDN Terminal initialization occurs when a terminal is installed, every time the system is sysloaded, or when the MISIP or the line card to which the terminal is connected is replaced.

### ISDN BRI terminal addressing

An ISDN BRI terminal connected to a DSL is addressed by using both the physical address and the logical address, where:

- the physical address is **l, s, c, dsl#** (or c, asl# for Option 11C) representing the *physical* (layer 1) identifier
- the logical address is defined as Terminal End-point Identifier (TEI), which is a *data link* (layer 2) identifier and the Terminal Service Profile (TSP), which is a *network* (layer 3) identifier

The User Service Identifier (USID) uniquely identifies the Terminal Service Profile (TSP) number (there may be up to **16 TSPs** per DSL.) The Service Profile ID (SPID) is a reference to the TSP, which contains the DN.

The SPID is an identification number (any combination of 1-20 alphanumeric characters) that is configured in overlay 27. The SPID is entered in overlay 27, in association with the TSP, and is also entered on the terminal keypad during initialization. All the terminals on a DSL that share the same TSP will have the same USID.

### **Assigning the Terminal End-point Identifier**

A Terminal End-point Identifier (TEI) is associated with establishing the *data link* (layer 2) connection between a terminal and the network. The TEI is a terminal logical address that is used by the MISP to address a terminal during the exchange of layer 2 information messages with that terminal. Each logical terminal is associated with one unique TEI. Up to 20 TEIs can be assigned to the logical terminals on one DSL.

Meridian 1 provides two types of TEIs based on their assignment method. These are:

- dynamic TEI, automatically assigned by the MISP
- static TEI, entered into the terminal by the user on the terminal key pad

### **Dynamic TEI**

Terminals supporting the dynamic TEI assignment receive their TEI automatically when the terminal is connected to the DSL. The MISP detects the terminal on the loop and assigns to it an unassigned TEI. The range of the automatically assignable TEI numbers is from 64 to 126. TEI 127 is used for sending broadcast messages. A different TEI may be dynamically assigned by the system every time it is initialized.

### **Static TEI**

The terminals that do not support dynamic TEI assignment use static TEI assignment. The TEI can be uniquely identified at the data link layer 2). It can be assigned to one logical terminal at a time, that is, there is a one-to-one mapping of TEI to logical terminal.

The static TEI assignment is performed by entering an unassigned TEI number from 0 to 63 directly into the terminal using its key pad. This TEI is assigned to that terminal as long as the terminal is operational. If the terminal becomes inoperative, the associated DSL has to be reinitialized.

**Note:** A packet data terminal must be of the static TEI type.

Figure 26 illustrates how a single physical termination may actually connect multiple logical terminals. Each ST-interface DSL can support up to eight physical terminations, and up to 20 logical terminals. Each logical terminal has assigned one unique TEI, which represents the layer 2 logical address for that terminal.

**Figure 26**  
**Multiple logical terminals on one physical termination**

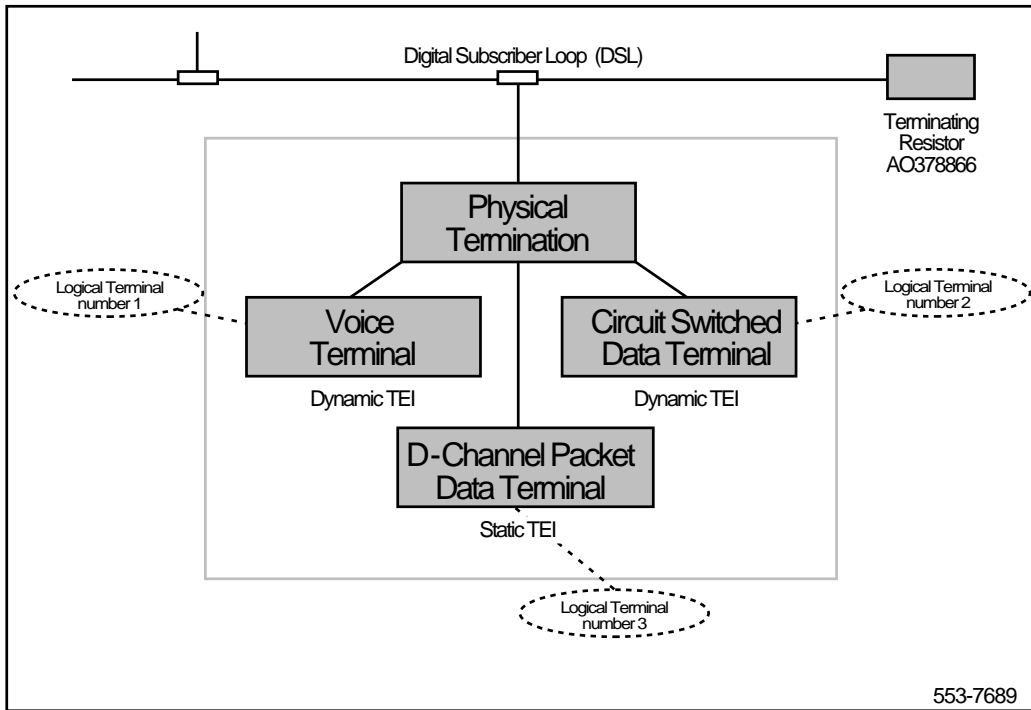

### Types of ISDN BRI terminals

ISDN BRI terminals are divided into four categories based on layer 3 and layer 2 initialization procedures:

- initializing terminal with dynamic TEI assignment
- initializing terminal with static TEI assignment

- non-initializing terminal with dynamic TEI assignment
- non-initializing terminal with static TEI assignment

### **Initializing terminal with dynamic TEI assignment**

Each initializing terminal has an identification number called a Service Profile ID (SPID) that is entered into the terminal by the user when the terminal is installed. This number is usually the directory number with one or two alphanumeric characters appended to it, although it can be any alphanumeric number up to 20 digits long. The SPID is used by the MISP to identify the terminal and to assign to it specific service attributes during layer 3 initialization.

Before layer 3 terminal initialization can start, layer 2 must be fully established, which includes TEI assignment. The TEI may be Dynamic (the MISP assigns an unassigned TEI) or Static (the TEI is manually entered on the terminal key pad). The terminal must then have its SPID number entered at the terminal key pad.

Layer 3 initialization with dynamic TEI assignment starts when the terminal transmits its SPID to the MISP using an information message. The MISP acknowledges the message and sends an end-point identifier message that contains two identification parameters; the User Service Identifier (USID) and the Terminal Identifier (TID).

### **Initializing terminal with static TEI assignment**

For an initializing terminal that does not support the dynamic TEI assignment, the end-point identification parameters USID and TID are not automatically assigned by the MISP. Before layer 3 terminal initialization can start, the terminal must have its SPID entered at the terminal keypad

Layer 3 initialization starts when the terminal transmits its SPID to the MISP using an information message. The MISP acknowledges the message and assigns a TSP to the terminal.

### **Non-initializing terminal with dynamic TEI assignment**

A non-initializing terminal does not support the dynamic TEI assignment and is not associated with a SPID number. However, non-initializing terminals may support dynamic TEI assignment where the MISP automatically assigns an unassigned TEI when the terminal is installed or when the system or the cards are reset.

The range of the automatically assignable TEI numbers is from 64 to 126. Because these terminals do not support layer 3 initialization procedures, the MISP assigns the same default TSP to all terminals of this type on a specific DSL. The default TSP is defined by specifying USID = 0 in overlay 27.

### **Non-initializing terminal with static TEI assignment**

A non-initializing terminal does not support the dynamic TEI assignment and is not associated with a SPID number. The non-initializing terminals may support static TEI assignment where the user assigns an unassigned TEI by entering the TEI number on the terminal key pad when the terminal is installed or when the system or the cards are initialized.

The static TEI assignment is performed by entering an unassigned TEI number from 0 to 63 directly into the terminal using its key pad. Because these terminals do not support layer 3 initialization procedures, the MISP assigns the same default TSP to all terminals of this type on a specific DSL. The default TSP is defined by specifying USID = 0 in overlay 27.

Figure 27 shows different types of terminals and their relationship to each other when they are connected to the same DSL. It also shows how the terminal initialization parameters are handled for different types of terminals.



**Figure 27**  
**Terminal initialization and service profile assignment examples**

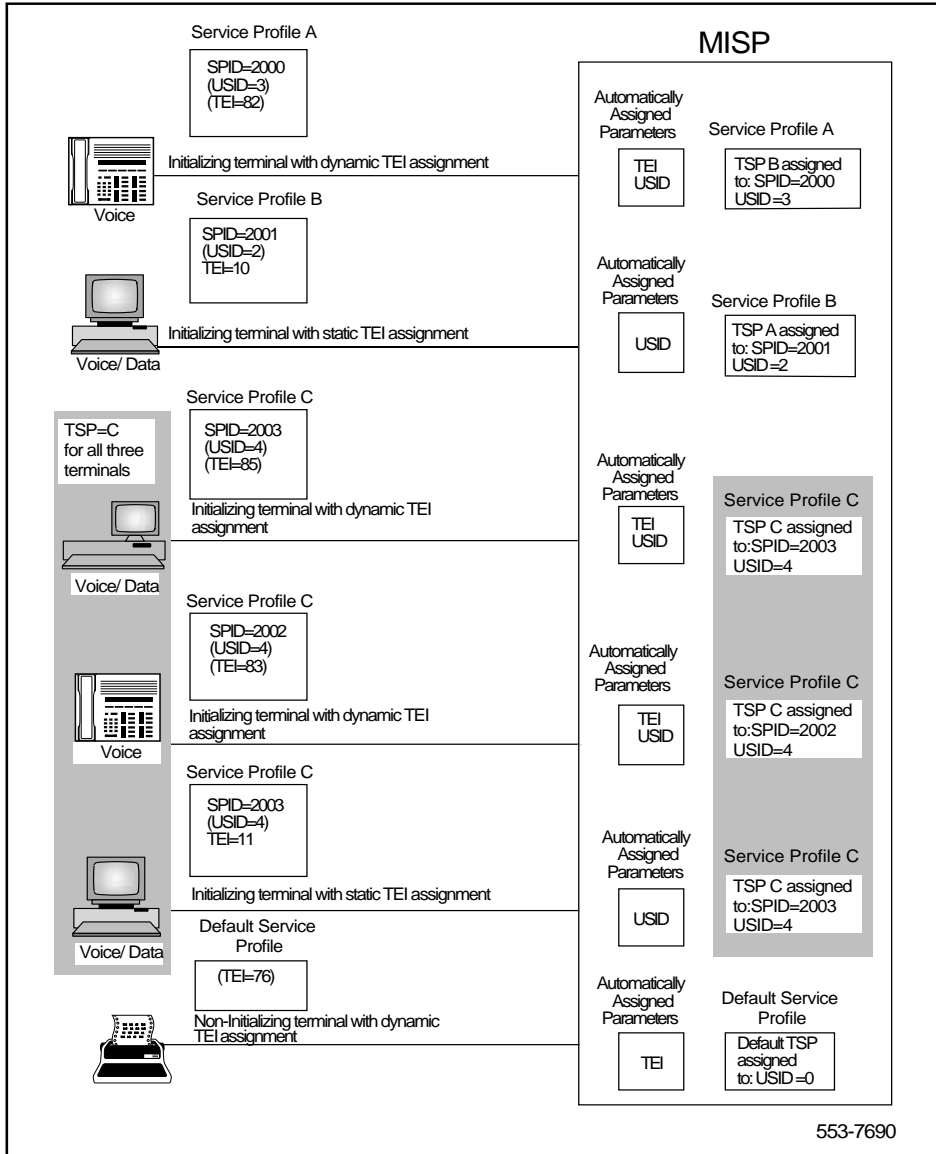

## ISDN BRI terminal interface specification

ISDN BRI provides two types of interfaces. They are:

- S/T interface
- U interface

A terminal connected to an interface over a DSL must meet the interface specification requirements. Each terminal must provide a jack of the appropriate type and with the appropriate pinouts for the interface.

### S/T interface specification

The S/T interface uses an 8-conductor modular cable terminated with an 8-pin RJ-45 plug. An 8-pin RJ-45 jack located on the terminal is used to connect the terminal to the DSL using this modular cable. Table 14 shows the connector pin assignment for the jack and the plug, from the NT1 side to the terminal. It also shows the signal names for each interface pin at the SILC and at the terminal.

**Note:** Power Sink 2 provides an optional means of powering the terminal from a common supply in the wiring closet. Power Source 3 provides the power from the terminal to the NT1 if the NT1 does not have a local power source. Up to 2 watts of power is supplied by the SILC to the terminals on the DSL. This power is simplexed over the Tx and Rx pairs provided by -48 V (-40 V for Europe) supply on the SILC. The Rx pair is positive with respect to the Tx pair.

**Table 14**  
**S/T interface connector specification, from NT1 to terminal**

Pin number	Terminal pin signal name	SILC pin signal name
1	Power Source 3	Not applicable
2	Power Source 3	Not applicable
3	Tx +	Rx +
4	Rx +	Tx +
5	Rx -	Tx -
6	Tx -	Rx -
7	Power Sink 2 (-)	Not applicable
8	Power Sink 2 (+)	Not applicable

## U interface specification

The U interface uses a 2-conductor twisted pair cable terminated with a RJ-45 jack. An RJ-45 jack located on the terminal is used to connect the terminal to the DSL using this twisted pair cable.

The connector pin assignments for the jack and plug are shown in Table 15. The table also shows the signal names for each interface pin at the UILC and at the terminal.

**Note:** The U interface meets all the safety protection requirements specified by UL (1459), CSA, TUV, and FCC (68.302 and 68.304). These requirements provide protection against inside and outside plant foreign voltages. In addition to other protection components used on the board, 1-Amp (125V voltage rating) fuses are used in series to ensure all the safety requirements. These fuses must be replaced if needed with the same type and rating only to continuously protect against the risk of fire.

**Table 15**  
**U interface connector specification**

Pin Number	Terminal Pin Signal Name	UILC Pin Signal Name
1	Not used	Not applicable
2	Not used	Not applicable
3	Not used	Not applicable
4	Transmit or Receive	Transmit or Receive
5	Transmit or Receive	Transmit or Receive
6	Not used	Not applicable
7	Not used	Not applicable
8	Not used	Not applicable

## Compatible ISDN BRI terminals

The list of terminals deemed compatible may change without notice. Refer to Table 16.

To obtain the latest list of compatible terminals and ordering codes, contact your Nortel Networks representative.

**Table 16**  
**ISDN BRI terminals**

Terminal type	Description
M5317TDX	A Meridian 1 telephone equipped with voice transmission options and circuit-switched or packet data options. <b>Note:</b> M5317TX is voice only.
M5209TDcp	A Meridian 1 telephone equipped with voice transmission options and circuit-switched or packet data options. <b>Note:</b> M5209T is voice only.
M5000TD-1	ISDN Terminal Adapter provides a connection to an analog telephone and supports circuit-switched or packet data.

---

# Features on ISDN BRI

---

## Reference

For information on Generic X11 software feature support for ISDN BRI, refer to *Networking Features and Services* (553-2901-301).





Meridian 1 and Succession Communication  
Server for Enterprise 1000

## **ISDN Basic Rate Interface**

### Product Description

Copyright © 1992–2002 Nortel Networks

All Rights Reserved

Information is subject to change without notice. Nortel Networks reserves the right to make changes in design or components as progress in engineering and manufacturing may warrant. This equipment has been tested and found to comply with the limits for a Class A digital device pursuant to Part 15 of the FCC rules, and the radio interference regulations of Industry Canada. These limits are designed to provide reasonable protection against harmful interference when the equipment is operated in a commercial environment. This equipment generates, uses and can radiate radio frequency energy, and if not installed and used in accordance with the instruction manual, may cause harmful interference to radio communications. Operation of this equipment in a residential area is likely to cause harmful interference in which case the user will be required to correct the interference at their own expense.

SL-1, Meridian 1, and Succession are trademarks of Nortel Networks.

Publication number: 553-3901-100

Document release: Standard 8.00

Date: January 2002

Printed in Canada

