Meridian 1

Line Cards

Description

Document Number: 553-3001-105

Document Release: Standard 7.00

Date: January 2002

Copyright © 1994 – 2002 Nortel Networks
All Rights Reserved

Printed in Canada

Information is subject to change without notice. Nortel Networks reserves the right to make changes in design or components as progress in engineering and manufacturing may warrant. This equipment has been tested and found to comply with the limits for a Class A digital device pursuant to Part 15 of the FCC rules, and the radio interference regulations of Industry Canada. These limits are designed to provide reasonable protection against harmful interference when the equipment is operated in a commercial environment. This equipment generates, uses and can radiate radio frequency energy, and if not installed and used in accordance with the instruction manual, may cause harmful interference to radio communications. Operation of this equipment in a residential area is likely to cause harmful interference in which case the user will be required to correct the interference at their own expense.

SL-1 and Meridian 1 are trademarks of Nortel Networks.

Revision history

January 2002

Standard 7.00. This document is up-issued to include content changes for Meridian 1 Internet Enabled Release 25.40.

April 2000

Standard 6.00. This is a global document and is up-issued for X11 Release 25.0x. Document changes include removal of: redundant content; references to equipment types except Options 11C, 51C, 61C, and 81C; and references to previous software releases.

June 1999

Standard, release 5.00.

October 1997

Standard, release 4.00. This document is reissued to include the NT5D60AA CLASS Modem Card (XCMC).

August 1996

Standard, release 3.00. This document is reissued to include the NT5D11 Line-side T1 Interface Card.

July 1995

Standard, release 2.00. This document is reissued to incorporate technical corrections.

December 1994

Standard, release 1.00. This is the initial release of this document. It supersedes:

- *NT8D02 Digital Line Card description (553-3001-162)*
- *NT8D09 Analog Message Waiting Line Card description (553-3001-163)*
- *500/2500 line cards description and operation (553-2201-183)*
- *QPC578 Integrated Services Digital Line Card description (553-2201-193)*

This document also contains information on the new NT1R20 Off-premise Station Analog Line Card.

Contents

About this document	9
Reference list	9
Description	11
Contents	11
Overview	12
Select a line card	13
Installation	16
Operation	17
Voice frequency audio level	42
Off-premise line protection	42
NT1R20 Off-Premise Station Analog Line Card ..	47
Contents	47
Reference list	48
Introduction	48
Physical description	48
Functional description	51
Card functions	52
Electrical specifications	54
Connector pin assignments	57
Configuring the OPS analog line card	59
Applications	63

NT5D11 Line-side T1 Interface Card	69
Contents	69
Reference list	70
Introduction	70
Physical description	70
Functional description	75
Electrical specifications	80
Installation and Configuration	81
Man-Machine T1 maintenance interface software	100
Applications	119
NT5D33 and NTRB34 Line-side E1 Interface Cards	125
Contents	125
Reference list	126
Introduction	126
Physical description	126
Functional description	131
Electrical specifications	135
Installation and Configuration	137
Installation	144
Man-Machine E1 maintenance interface software	155
NT5D60AA CLASS Modem Card (XCMC)	185
Contents	185
Reference list	185
Introduction	185
Physical description	186
Functional description	186
Electrical specifications	189
Configuration	190

NT8D02 Digital Line Card	191
Contents	191
Reference list	191
Introduction	192
Physical description	192
Functional description	194
Electrical specifications	199
Connector pin assignments	201
Configuration	203
NT8D09 Analog Message Waiting Line Card	205
Contents	205
Reference list	206
Introduction	206
Physical description	207
Functional description	209
Electrical specifications	213
Connector pin assignments	216
Configuration	218
Index	221
List of terms	227

About this document

This document is a global document. Contact your system supplier or your Nortel Networks representative to verify that the hardware and software described is supported in your area.

This document outlines the functions, specifications, applications, and operation of the various Meridian 1 line cards. This information is intended to be used as a guide when connecting the line cards to customer-provided station equipment.

Reference list

See the Meridian 1 System planning and engineering guide for

- *System Engineering* (553-3001-151)
- *Spares Planning* (553-3001-153)
- *Equipment Identification* (553-3001-154)
- *Summary of Transmission Parameters* (553-2201-182)

See the Meridian 1 System installation and maintenance guide for

- *System Installation Procedures* (553-3001-210)
- *Circuit Card: Installation and Testing* (553-3001-211)
- *General Maintenance Information* (553-3001-500)
- *Fault Clearing* (553-3001-510)
- *Hardware Replacement* (553-3001-520)

See the following software guides for an overview of software architecture, procedures for software installation and management, and a detailed description of all features and services. This information is contained in two documents:

- *System Management* (553-3001-300)
- *Features and Services* (553-3001-306)

See the *Administration* (553-3001-311) for a description of all administration and maintenance programs, and *System Messages Guide* (553-3001-411) for information about system messages.

Description

Contents

This section contains information on the following topics:

Overview	12
Select a line card	13
Intelligent peripheral equipment line cards	14
Installation	16
Operation	17
Host interface bus	17
Analog line interface units	23
Digital line interface units	26
Analog line call operation	27
Digital line call operation	34
Line-side T1 call operation	34
Voice frequency audio level	42
Off-premise line protection	42
Line protectors	43
Line protection grounding	44
Line and telephone components	45

Reference list

The following are the references in this section:

- *System Engineering* (553-3001-151)
- *System Installation Procedures* (553-3001-210)

- *Circuit Card: Installation and Testing (553-3001-211)*
- *X11 Administration (553-3001-311)*

Overview

This document describes the various line cards that are used with the Meridian 1 switch. It shows how the line cards fit into the Meridian 1 architecture, how they are used at the customer site, and how they are installed and programmed. It then provides detailed technical specifications on each of the cards.

This document describes five line cards:

- NT1R20 Off-Premise Station Analog Line Card
- NT5D11 Line-side T1 Interface Card
- NT5D33 and 34 Line-Side E1 Interface Card
- NT8D02 Digital Line Card
- NT8D09 Analog Message Waiting Line Card

Select a line card

Each of the line cards was designed to fit a specific system need. Table 1 lists the line card characteristics.

Table 1
Line card characteristics

Part Number	Description	Lines	Line Type	Message Waiting	Supervised Analog Lines	Architecture
NT1R20	Off-Premise Station Analog Line Card	8	Analog	Interrupted dial tone	Yes	IPE
NT5D11	Line-side T1 Interface Card	24	T1	None	Yes	IPE
NT5D33 /34	Line-side E1 Interface Card	30	E1	None	Yes	IPE
NT8D02	Digital Line Card (16 voice/16 data)	16	Digital	Message waiting signal forwarded to digital phone for display	No	IPE
NT8D09	Analog Message Waiting Line Card	16	Analog	Lamp	No	IPE

Intelligent peripheral equipment line cards

The following line cards are designed using the Intelligent Peripheral Equipment (IPE) architecture and are recommended for use in all new system designs.

NT1R20 Off-Premise Station Analog Line Card

The NT1R20 Off-Premise Station (OPS) Analog Line Card is an intelligent eight-channel analog line card designed to be used with 2-wire analog terminal equipment such as analog (500/2500-type) telephones and analog modems. Each line has integral hazardous and surge voltage protection to protect the Meridian 1 system from damage due to lightning strikes and accidental power line connections. This card is normally used whenever the phone lines have to leave the building in which the Meridian 1 switch is installed. The OPS line card supports message waiting notification by interrupting the dial tone when the receiver is first picked up. It also provides battery reversal answer and disconnect analog line supervision and hook flash disconnect analog line supervision features.

NT5D11 Line-side T1 Interface Card

The NT5D11 Line-side T1 Interface Card is an intelligent 24-channel digital line card that is used to connect the Meridian 1 switch to T1 compatible terminal equipment on the line-side. T1 compatible terminal equipment includes voice mail systems, channel banks containing FXS cards, and key systems such as the Nortel Networks Norstar. The line-side T1 card differs from trunk T1 cards in that it supports terminal equipment features such as hook-flash, transfer, hold, and conference. It emulates an analog line card to the Meridian 1 software.

NT5D33 and 34 Line-side E1 Interface Card

The NT5D33/34 Line-side E1 Interface Card is an intelligent 30-channel digital line card that is used to connect the Meridian 1 switch to E1 compatible terminal equipment on the line-side. E1 compatible terminal equipment includes voice mail systems. The line-side E1 card emulates an analog line card to the Meridian 1 software.

NT8D02 Digital Line Card

The NT8D02 Digital Line Card is an intelligent 16-channel digital line card that provides voice and data communication links between a Meridian 1 switch and modular digital telephones. Each of the 16 channels support voice-only or simultaneous voice and data service over a single twisted pair of standard telephone wire.

NT8D09 Analog Message Waiting Line Card

The NT8D09 Analog Message Waiting Line Card is an intelligent 16-channel analog line card designed to be used with 2-wire terminal equipment such as analog (500/2500-type) telephones, modems, and key systems. This card can also provide a high-voltage, low-current signal on the Tip and Ring pair of each line to light the message waiting lamp on phones equipped with that feature.

Installation

This section provides a high-level description of how to install and test line cards. For specific installation instructions, see *Circuit Card: Installation and Testing* (553-3001-211).

Intelligent Peripheral Equipment (IPE) line cards can be installed in any slot of the NT8D37 IPE Module. Figure 1 shows where an IPE line card can be installed in an NT8D37 IPE Module.

Figure 1
IPE line cards shown installed in an NT8D37 IPE Module

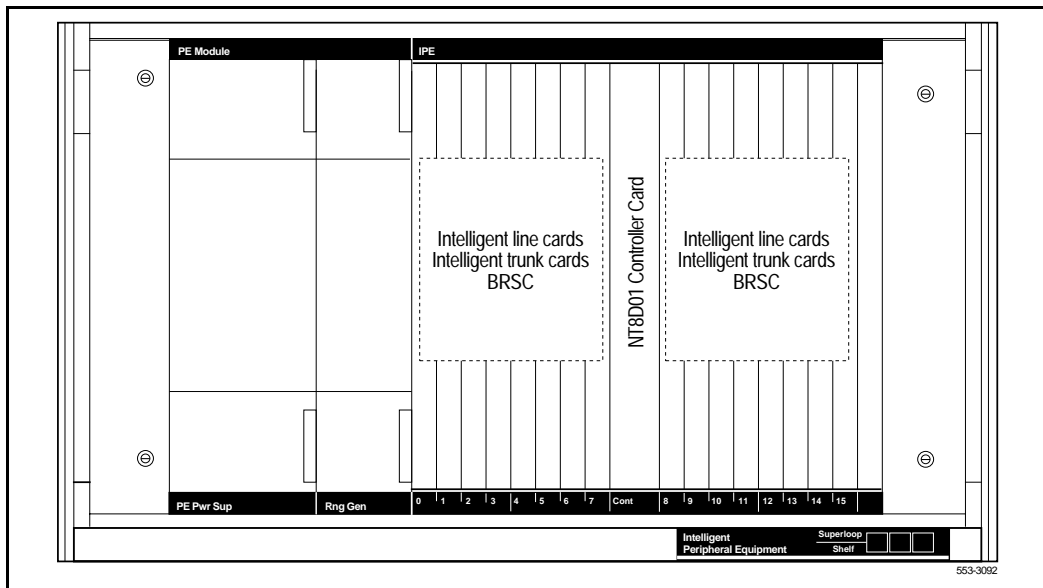

When installing line cards, follow these general procedures:

- Configure the jumpers and switches on the line card (if any) to meet system needs.
- Install the line card into the selected slot.
- Install the cable that connects the backplane connector on the IPE module to the module I/O panel.
- Connect a 25-pair cable from the module I/O panel connector to the Main Distribution Frame (MDF).
- Connect the line card output to the selected terminal equipment at the MDF.
- Configure the individual line interface unit using the Single-line Telephone Administration program LD 10 for analog line interface units and Multi-line Telephone Administration program LD 11 for digital line interface units.

Once these steps have been completed, the terminal equipment is ready for use.

Operation

This section describes how line cards fit into the Meridian 1 architecture, the busses that carry signals to and from the line cards, and how they connect to terminal equipment. These differences are summarized in Table 2 on page 18.

Host interface bus

Cards based on the IPE bus have a built-in microcontroller. The IPE microcontroller is used to do the following:

- perform local diagnostics (self-test)
- configure the card according to instructions issued by the Meridian 1 system processor
- report back to the Meridian 1 system processor information such as card identification (type, vintage, and serial number), firmware version, and programmed configuration status

Table 2
IPE module architecture

Parameter	Intelligent Peripheral Equipment
Card Dimensions	31.75 x 25.4 x 2.2 cm. (12.5 x 10.0 x 0.875 in.)
Network Interface	DS-30X Loops
Communications Interface	card LAN Link
Microcontroller	8031 / 8051 Family
Peripheral Interface Card	NT8D01 Controller Card
Network Interface Card	NT8D04 Superloop Network Card
Modules	NT8D37 IPE Module

Intelligent peripheral equipment

Intelligent Peripheral Equipment (IPE) line cards all have a similar architecture. Figure 2 shows a typical IPE line card architecture. The various line cards differ only in the number and types of line interface units.

Figure 2
Typical IPE analog line card architecture

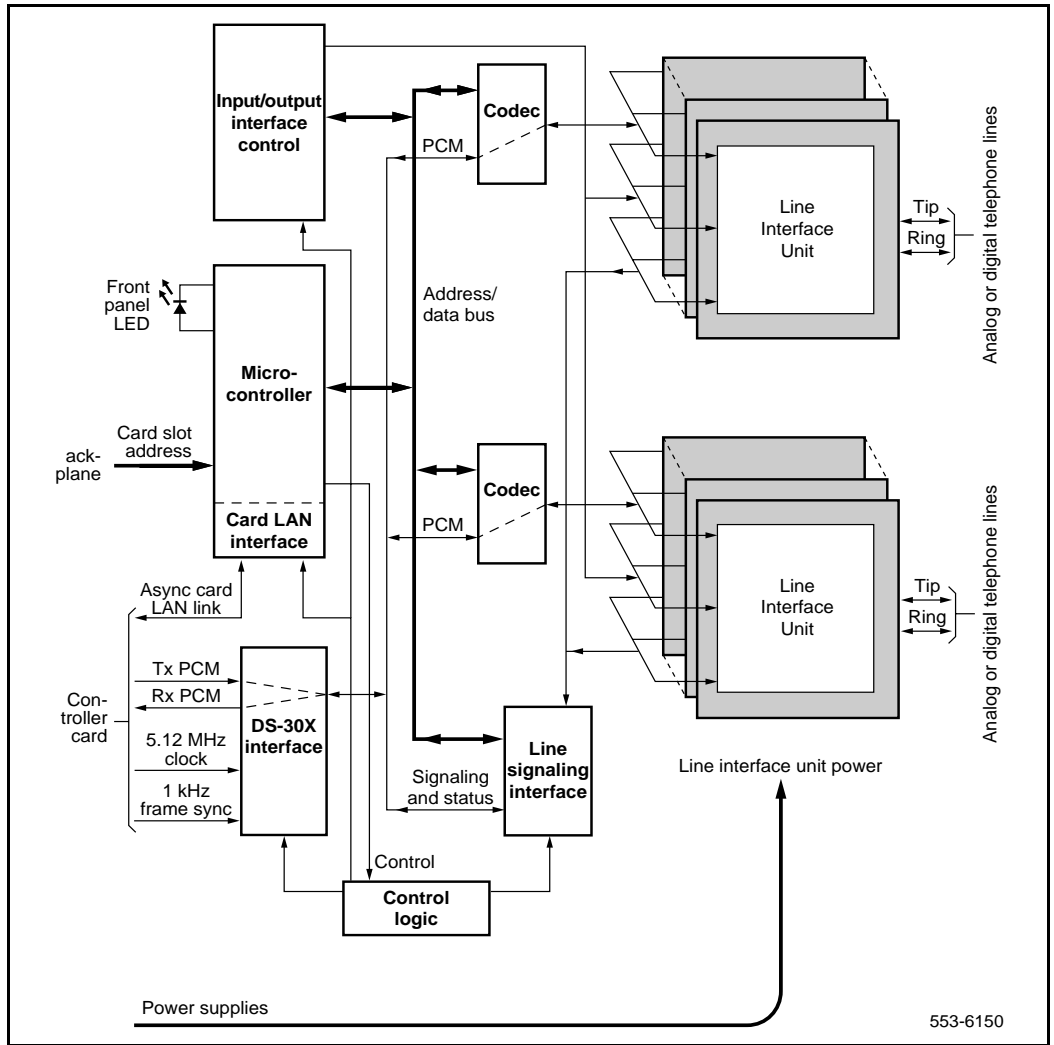

553-6150

The Meridian 1 switch communicates with IPE modules over two separate interfaces. Voice and signaling data are sent and received over DS-30X loops, and maintenance data is sent over a separate asynchronous communications link called the card LAN link.

Signaling data is information directly related to the operation of the telephone line. Some examples of signaling commands include:

- off-hook/on-hook
- ringing signal on/off
- message waiting lamp on/off

Maintenance data is data relating to the setup and operation of the IPE card, and is carried on the card LAN link. Some examples of maintenance data include:

- polling
- reporting of self-test status
- CP initiated card reset
- reporting of card ID (card type and hardware vintage)
- reporting of firmware version
- downloading line interface unit parameters
- reporting of line interface unit configuration
- enabling/disabling of the DS-30X network loop bus
- reporting of card status or T1 link status

DS-30X loops

The line interfaces provided by the line cards connect to conventional 2-wire (tip and ring) line facilities. IPE analog line cards convert the incoming analog voice and signaling information to digital form and route it to the Meridian 1 common equipment Call Processor (CP) over DS-30X network loops. Conversely, digital voice and signaling information from the CP is sent over DS-30X network loops to the analog line cards where it is converted to analog form and applied to the line facility.

IPE digital line cards receive the data from the digital phone terminal as 512 kHz Time Compressed Multiplexed (TCM) data. The digital line card converts that data to a format compatible with the DS-30X loop and transmits it in the next available timeslot. When a word is received from the DS-30X loop, the digital line card converts it to the TCM format and transmits it to the digital phone terminal over the digital line facility.

A separate dedicated DS-30X network loop is extended between each IPE line/trunk card and the controller cards within an IPE module. A DS-30X network loop is composed of two synchronous serial data buses. One bus transports in the Transmit (Tx) direction towards the line facility and the other in the Receive (Rx) direction towards the Meridian 1 Common Equipment.

Each bus has 32 channels for Pulse Code Modulated (PCM) voice data. Each channel consists of a 10-bit word. See Figure 3. Eight of the 10 bits are for PCM data, one bit is the call signaling bit, and the last bit is a data valid bit. The eight-bit PCM portion of a channel is called a timeslot. The DS-30X loop is clocked at 2.56 Mbps (one-half the 5.12 MHz clock frequency supplied by the controller card). Thus, the timeslot repetition rate for a single channel is 8 kHz. The controller card also supplies a locally generated 1 kHz frame sync signal for channel synchronization.

Figure 3
DS-30X loop data format

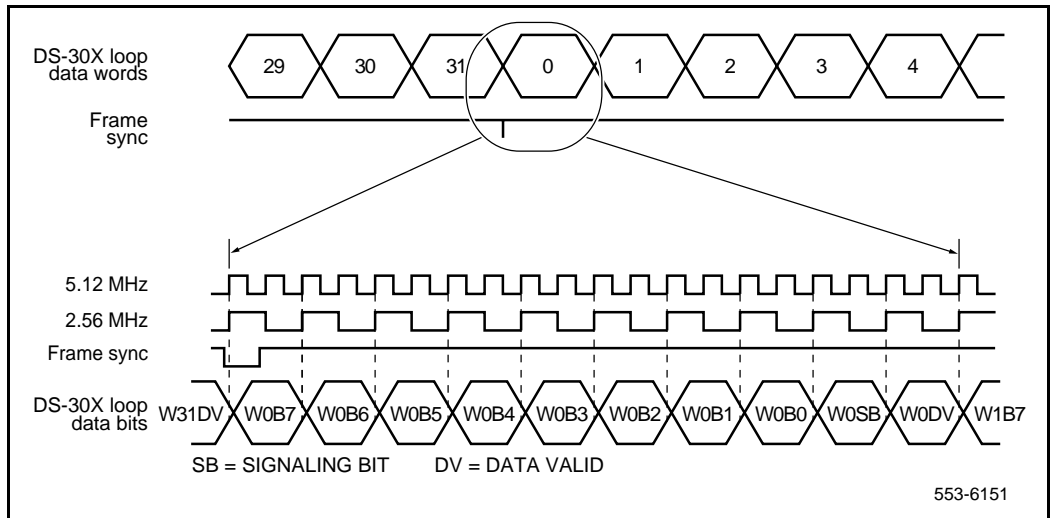

Signaling data is transmitted to and from the line cards using the call signaling bit within the 10-bit channel. When the line card detects a condition that the Meridian 1 switch needs to know about, it creates a 24-bit signaling word. This word is shifted out on the signaling bit for the associated channel one bit at a time during 24 successive DS-30X frames. Conversely, when the Meridian 1 switch sends signaling data to the line card, it is sent as a 24-bit word divided among 24 successive DS-30X frames.

DS-30Y network loops extend between controller cards and superloop network cards in the Common Equipment (CE). They function in a manner similar to DS-30X loops. See Figure 5 on page 26.

A DS-30Y loop carries the PCM timeslot traffic of a DS-30X loop. Four DS-30Y network loops form a superloop with a capacity of 128 channels (120 usable timeslots). See *System Engineering* (553-3001-151) for more information on superloops.

Card LAN link

Maintenance communications is the exchange of control and status data between IPE line or trunk cards and the CE CP by way of the NT8D01 Controller Card. Maintenance data is transported through the *card LAN* link. This link is composed of two asynchronous serial buses (called the Async card LAN link in Figure 2). The output bus is used by the Meridian 1 controller for output of control data to the line card. The input bus is used by the Meridian 1 controller for input of line card status data.

A card LAN link bus is common to all of the line/trunk card slots within an IPE module. This bus is arranged in a master/slave configuration where the controller card is the master and all other cards are slaves. The module backplane provides each line/trunk card slot with a unique hardwired slot address. This slot address enables a slave card to respond when addressed by the controller card. The controller card communicates with only one slave at a time.

In normal operation, the controller card continually scans (polls) all of the slave cards connected to the card LAN to monitor their presence and operational status. The slave card sends replies to the controller on the input bus along with its card slot address for identification. In its reply, the slave informs the controller if any change in card status has taken place. The controller can then prompt the slave for specific information. Slaves only respond when prompted by the controller; they do not initiate exchange of control or status data on their own.

When an IPE line card is first plugged into the backplane, it runs a self-test. When the self-test is completed, a properly functioning card responds to the next controller card poll with the self-test status. The controller then queries for card identification and other status information. The controller then downloads all applicable configuration data to the line card, initializes it, and puts it into an operational mode.

Analog line interface units

Once the 8-bit digital voice signal has been received by the analog line card, it must be converted back into an analog signal, filtered, converted from a 4-wire transmission path to a 2-wire transmission path, and driven onto the analog telephone line.

Figure 4 on page 24 shows a typical example of the logic that performs these functions. Each part of the analog line interface unit is discussed in the following section.

Coder/Decoder circuit

The Coder/Decoder (CODEC) performs Analog to Digital (A/D) and Digital to Analog (D/A) conversion of the line analog voiceband signal to and from a digital PCM signal. This signal can be coded and decoded using either the A-Law or the μ -Law companding algorithm.

On some analog line cards, the decoding algorithm depends of the type of CODEC installed when the board is built. On others, it is an option selected using a software overlay.

Figure 4
Typical analog line interface unit block diagram

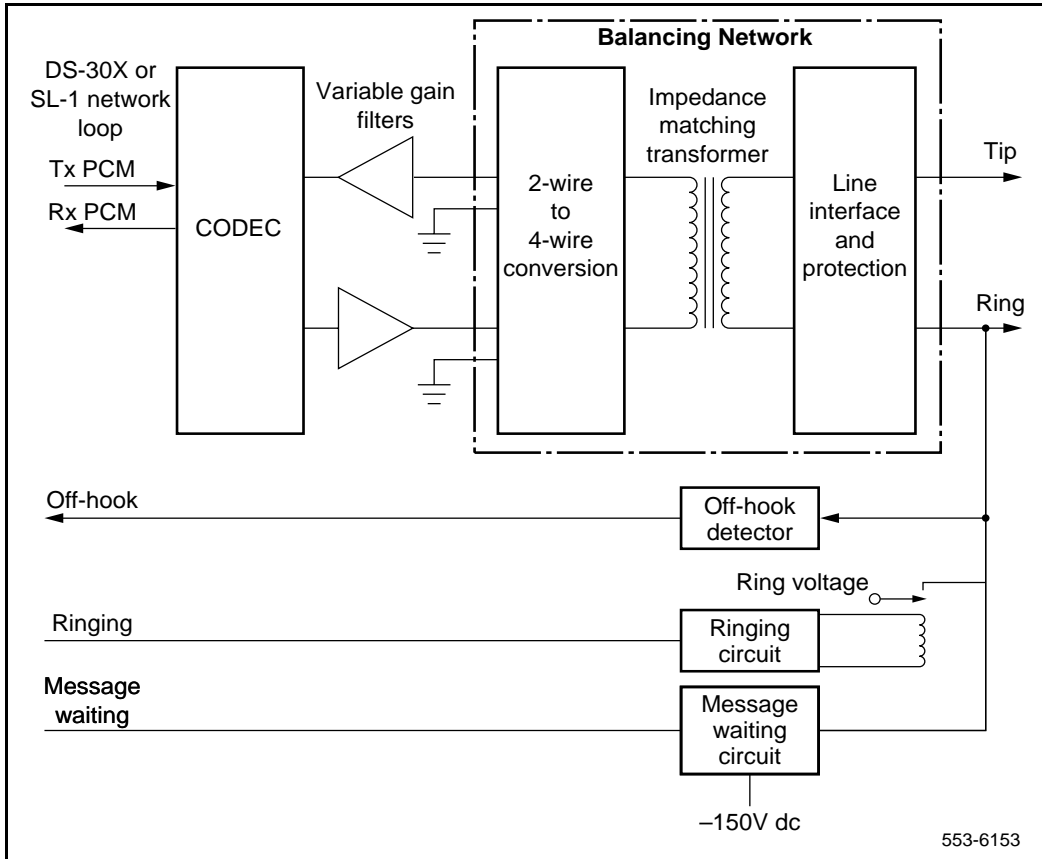

Variable gain filters

Audio signals received from the analog phone line are passed through a low-pass A/D monolithic filter that limits the frequency spread of the input signal to a nominal 200 to 3400 Hz bandwidth. The audio signal is then applied to the input of the CODEC. Audio signals coming from the CODEC are passed through a low-pass A/D monolithic filter that integrates the amplitude modulated pulses coming from the CODEC, and then filters and amplifies the result. On some of the line cards, the gain of these filters can be programmed by the system controller. This allows the system to make up for line losses according to the loss plan.

Balancing network

Depending on the card type, the balancing network provides a 600 $\frac{3}{4}$, 900 $\frac{3}{4}$, 3COM or 3CM2 impedance matching network.

It also converts the 2-wire transmission path (tip and ring) to a 4-wire transmission path (Rx/ground and Tx/ground). The balancing network is usually a transformer/analog (hybrid) circuit combination, but can also be a monolithic Subscriber Line Interface Circuit (SLIC) on the newer line cards.

Line interface and foreign voltage protection

The line interface unit connects the balancing network to the telephone tip and ring pairs. The off-premise line card (NT1R20) has circuitry that protects the line card from foreign voltage surges caused by accidental power line connections and lightning surges. This protection is necessary if the telephone line leaves the building where the switch is installed.

The line interface unit has a relay that applies the ringing voltage onto the phone line. See Figure 4 on page 24. The RSYNC signal from the 20 Hz (nominal) ringing voltage power supply is used to prevent switching of the relay during the current peak. This eliminates switching glitches and extends the life of the switching relay.

The off-hook detection circuit monitors the current draw on the phone line. When the current draw exceeds a preset value, the circuit generates an off-hook signal that is transmitted back to the system controller.

The message waiting circuit on message waiting line cards monitors the status of the message waiting signal and applies -150 V dc power to the tip lead when activated. This voltage is used to light the message waiting lamps on phones that are equipped with that feature. The high voltage supply is automatically disconnected when the phone goes off-hook. Newer line cards can sense when the message waiting lamp is not working and can report that information back to the system controller.

Digital line interface units

The NT8D02 digital line card provides voice and data communication links between a Meridian 1 switch and modular digital telephones. These lines carry multiplexed PCM voice, data and signaling information as Time Compression Multiplexed (TCM) loops. Each TCM loop can be connected to a Nortel Networks “Meridian Modular Digital” telephone.

The digital line interface card contains one or more digital line interface units. See Figure 5 on page 26. Each digital line interface unit contains a Digital Line Interface Circuit (DLIC). The purpose of each DLIC is to demultiplex data from the DS-30X Tx channel into integrated voice and data bitstreams and transmit those bitstreams as Bi-Polar Return to Zero, Alternate Mark Inversion (BPRZ-AMI) data to the TCM loop. It also does the opposite: receives BPRZ-AMI bitstreams from the TCM loop and multiplexes the integrated voice and data bitstream onto the DS-30X Rx channel.

Figure 5
Digital line interface unit block diagram

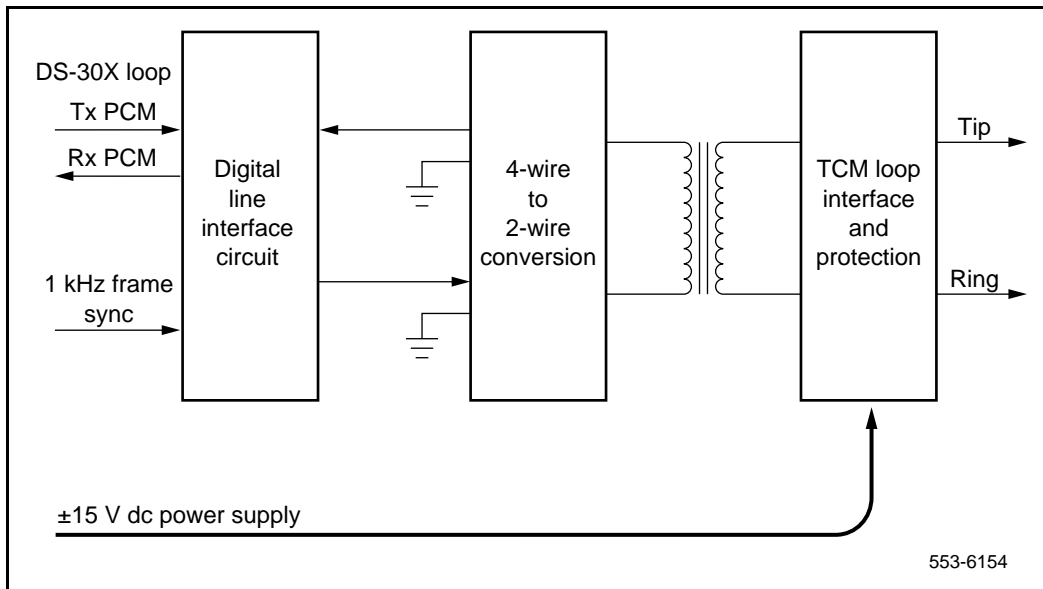

The 4-wire to 2-wire conversion circuit converts the 2-wire tip and ring leads into a 4-wire (Tx and ground and RX and ground) signal that is compatible

with the digital line interface circuit.

TCM loop interfaces

Each digital phone line terminates on the digital line card at a TCM loop interface circuit. The circuit provides transformer coupling and foreign voltage protection between the TCM loop and the digital line interface circuit. It also provides power for the digital telephone.

To prevent undesirable side effects from occurring when the TCM loop interface cannot provide the proper signals on the digital phone line, the system controller can remove the ± 15 V dc power supply from the TCM loop interface. This happens when either the card gets a command from the NT8D01 Controller Card to shut down the channel, or when the digital line card detects a loss of the 1 KHz frame synchronization signal.

Each TCM loop interface circuit can service loops up to 3500 ft. in length when using 24 gauge wire. The circuit allows for a maximum ac signal loss of 15.5 dB at 256 KHz and a maximum DC loop resistance of 210 ohms.

Signaling

The digital line interface units also contain signaling and control circuits that establish, monitor, and take down call connections. These circuits work with the system controller to operate the digital line interface circuits during calls. The circuits receive outgoing call signaling messages from the controller and return incoming call status information to the controller over the DS-30X network loop.

Analog line call operation

The applications, features, and signalling arrangements for each line interface unit are configured in software and implemented on the card through software download messages. When an analog line interface unit is idle, it provides a voltage near ground on the tip lead and a voltage near -48 V dc on the ring lead to the near-end station. (The near-end station is the telephone or device that is connected to the analog line card by the tip and ring leads.) An on-hook telephone presents a high impedance toward the line interface unit on the card.

Incoming calls

Incoming calls to a telephone that is connected to an analog line card can originate either from stations that are local (served by the Meridian 1 PBX), or remote (served through the public switched telephone network (PSTN)). The alerting signal to a telephone is 20 Hz (nominal) ringing. When an incoming call is answered by the near-end station going off-hook, a low-resistance DC loop is placed across the tip and ring leads (towards the analog line card) and ringing is tripped. See Figure 6 on page 29.

Outgoing calls

For outgoing calls from the near-end station, a line interface unit is seized when the station goes off-hook, placing a low-resistance loop across the tip and ring leads towards the analog line card. See Figure 7 on page 30. When the card detects the low-resistance loop, it prepares to receive digits. When the Meridian 1 is ready to receive digits, it returns dial tone. Outward address signaling is then applied from the near-end station in the form of loop (interrupting) dial pulses or DTMF tones.

Message waiting

Line cards that are equipped with the message waiting feature receive notification that a message is waiting across the Card LAN link (IPE cards). On cards that drive a message waiting light, the light is turned on by connecting the ring side of the telephone line to the -150 V dc power supply. When the line card senses that the telephone has gone off-hook, it removes the -150 V dc voltage until the telephone goes back on-hook. Line cards that use an interrupted dial tone to indicate message waiting do nothing until the receiver is picked up. The line card then interrupts the dial tone at a regular interval to indicate that a message is waiting.

Figure 6
Call connection sequence – near-end station receiving call

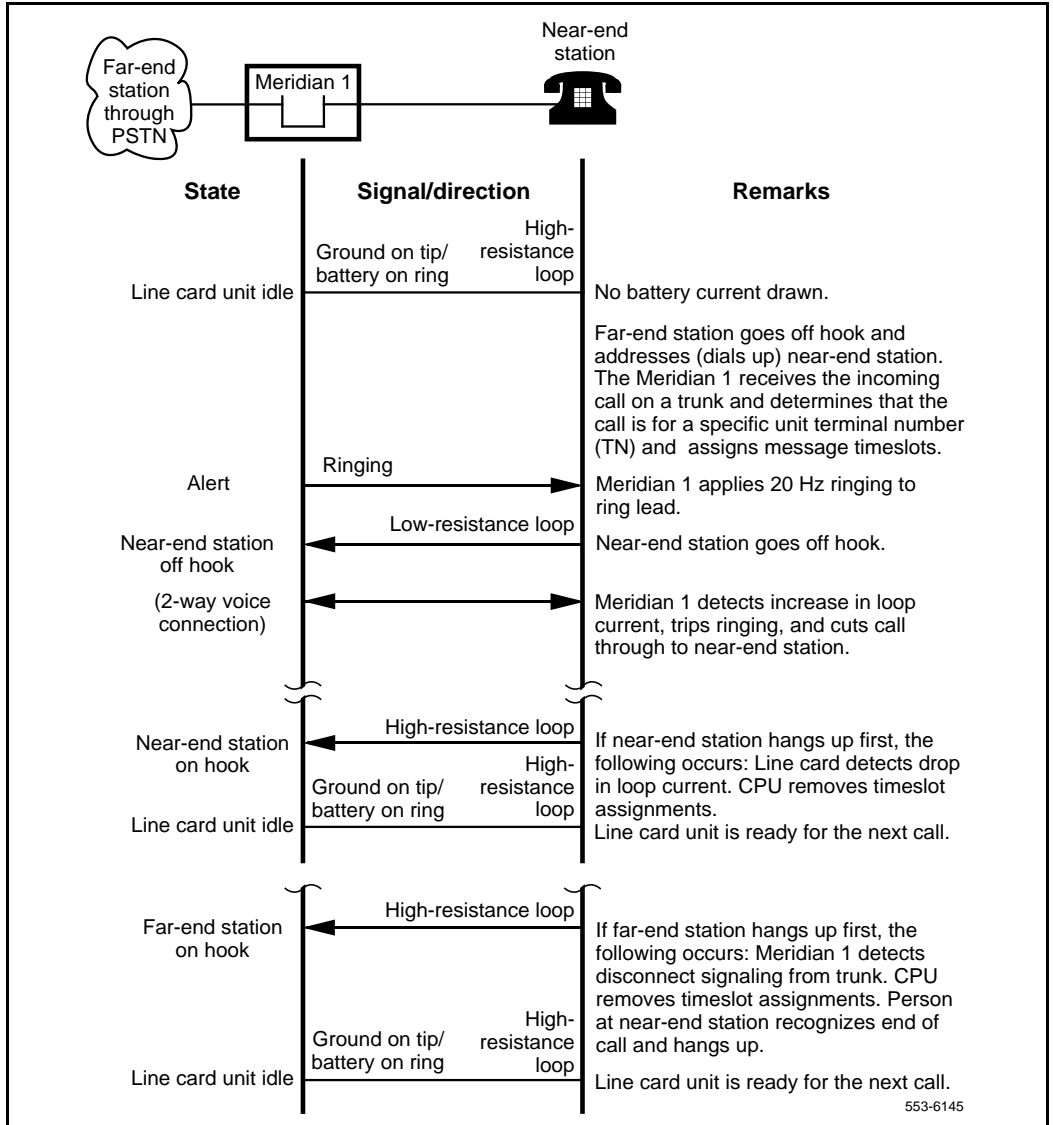
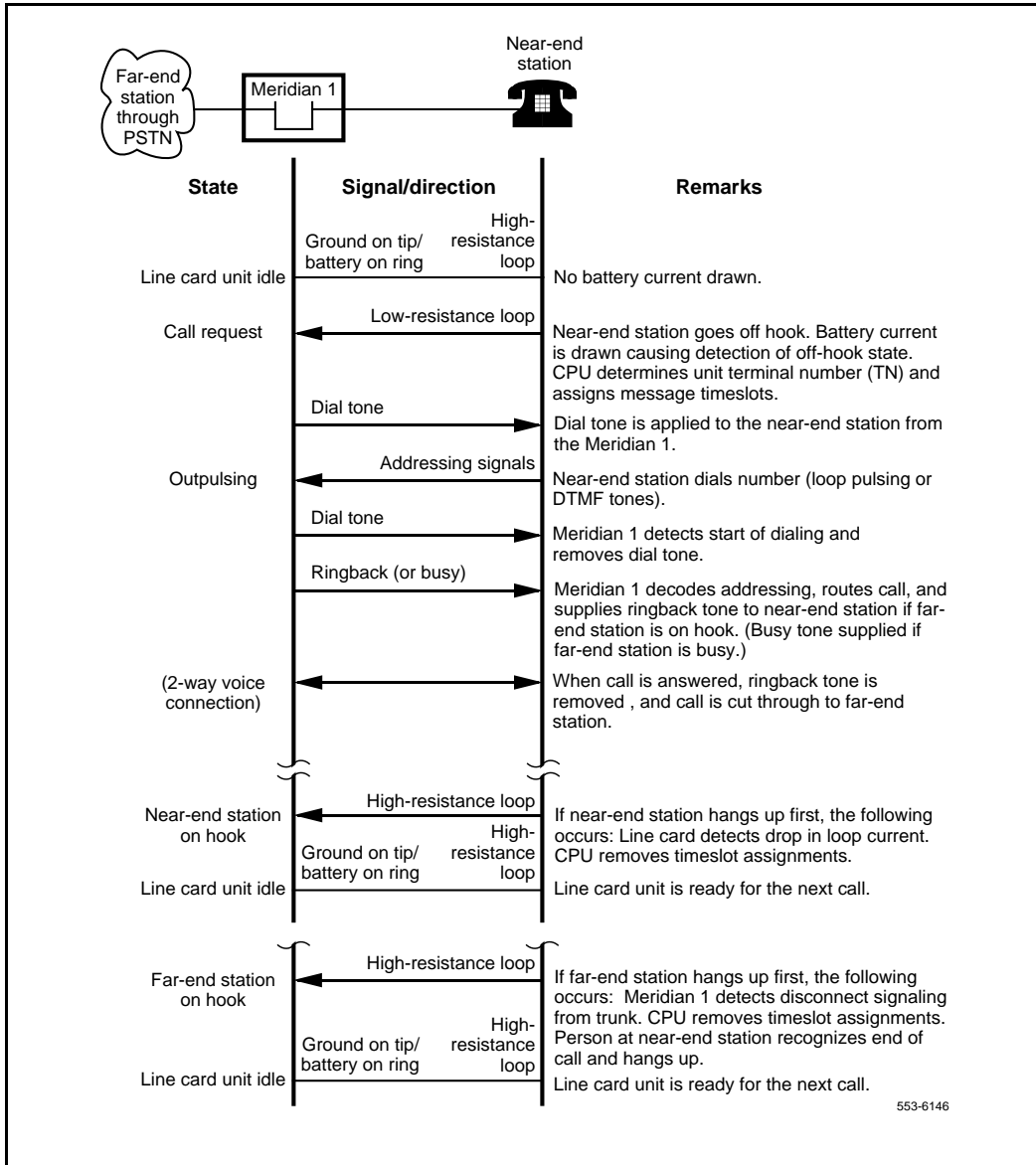

Figure 7
Call connection sequence – near-end originating call



In both cases, the message waiting indication will continue until the user checks his or her messages. At that time, the Meridian 1 system will cancel the message waiting indication by sending another message across the Card LAN link or Meridian 1 network loop.

Analog line supervision

Analog line supervision features are used to extend the answer supervision and disconnect supervision signals when the line card is connected to an intelligent terminal device (Key system or intelligent pay phone). Two types of analog line supervision are provided:

- battery reversal answer and disconnect supervision
- hook flash disconnect supervision

Battery reversal answer and disconnect supervision

Battery reversal answer and disconnect supervision is only used for calls that originate from the terminal device. It provides both far-end answer supervision and far-end disconnect supervision signals to the terminal device. In an intelligent pay phone application, these signals provide the information necessary to accurately compute toll charges.

In the idle state, and during dialing and ringing at the far end, the line card provides a ground signal on the tip lead and battery on the ring lead. See Figure 8 on page 32. When the far-end answers, these polarities are reversed. The reversed battery connection is maintained as long as the call is established. When the far-end disconnects, the Meridian 1 system sends a message that causes the line card to revert the battery and ground signals to the normal state to signal that the call is complete.

Hook Flash disconnect supervision

Hook flash disconnect supervision is only used for incoming calls that terminate at the terminal device (typically a Key system). See Figure 9 on page 33. The disconnect signal is indicated by the removal of the ground connection to the tip lead for a specific length of time. The length of time is programmed in LD10, and ranges from a minimum of 10 milliseconds to a maximum of 2.55 seconds. See *X11 Administration* (553-3001-311) for more information.

Figure 8
Battery reversal answer and disconnect supervision sequence

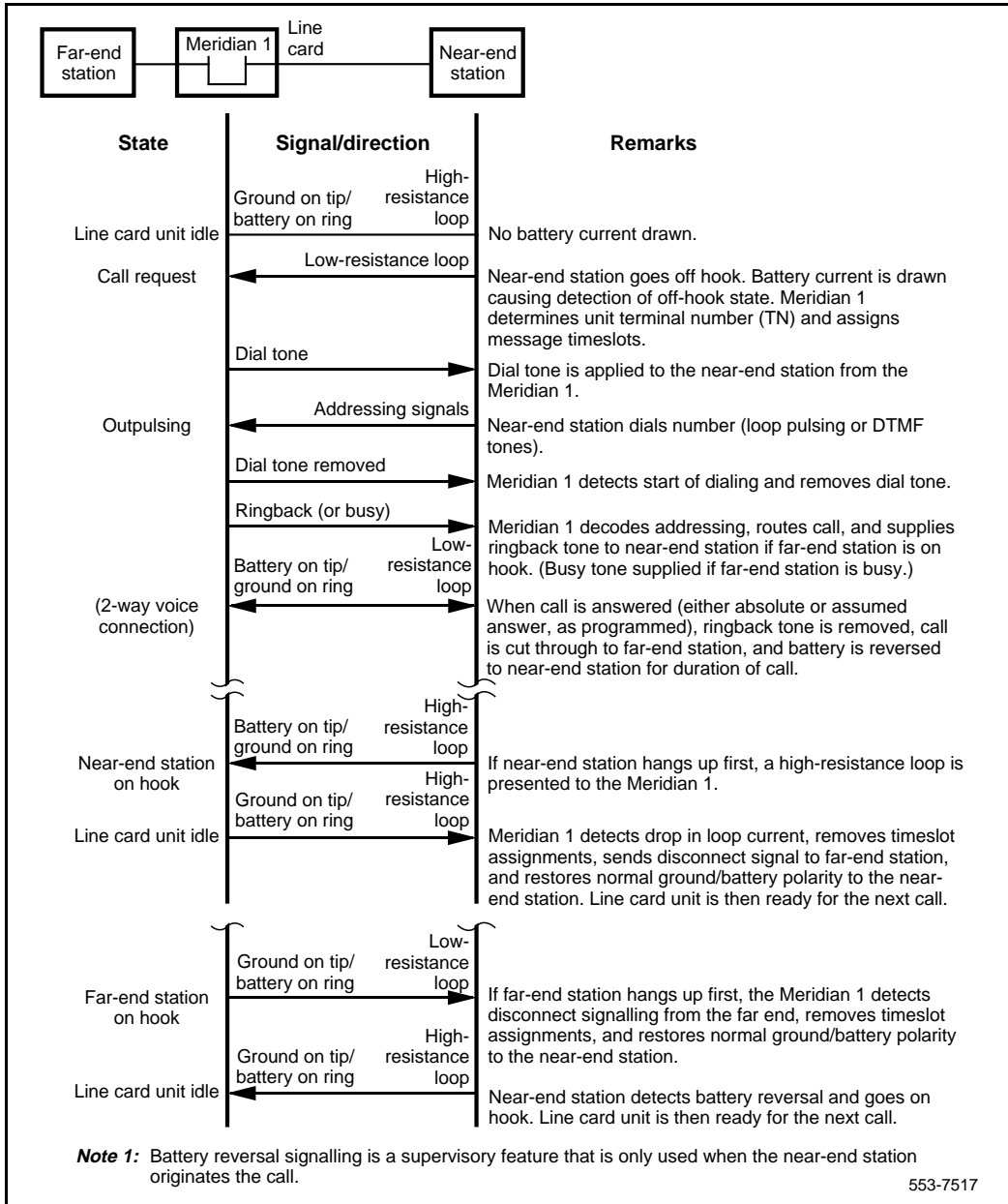
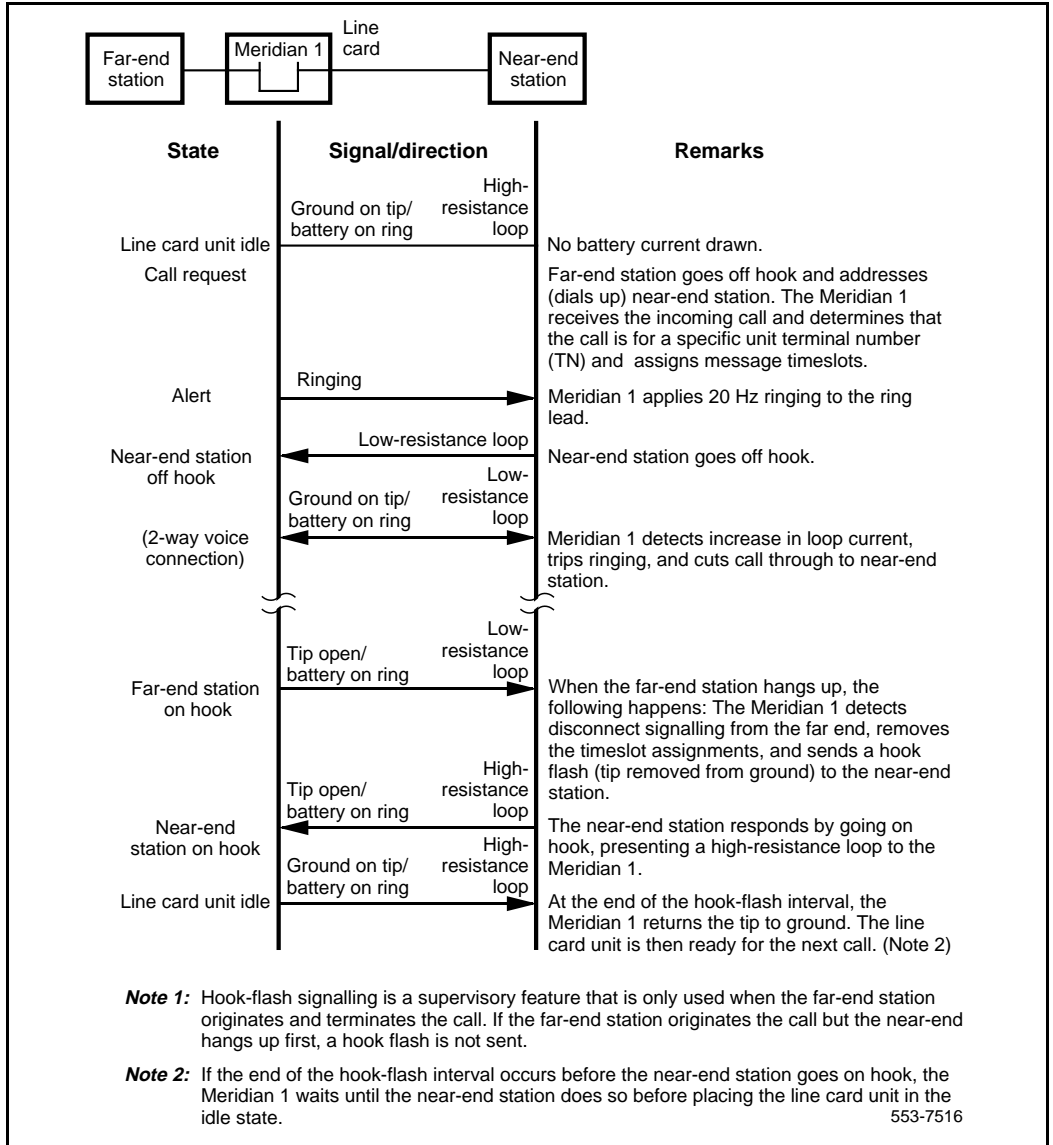

Figure 9
Hook flash disconnect supervision sequence



Digital line call operation

Digital line call operation is controlled entirely by use of messages between the digital telephone and the Meridian 1 system. These messages are carried across the TCM loop interface. There is no call connection sequence similar to the one used for analog telephone line operation.

Line-side T1 call operation

The line-side T1 card's call operation is performed differently depending on whether the T1 link is configured to process calls in loop start mode or ground start mode. Configuration is performed through dip switch settings on the line-side T1 card.

The line-side T1 card performs calls processing separately on each of its 24 channels. Signaling is performed using the "A/B robbed bit" signaling standard for T1 communication.

A/B robbed bit signaling simulates standard analog signaling by sending a meaningful combination of ones and zeros across the line that correlates to the electrical impulses that standard analog signaling sends. For example, to represent that an analog line interface unit is idle, the analog line card provides a ground on the tip lead and -48Vdc on the ring lead. The line-side T1 card accomplishes the same result by sending its A bit as 0 (translated as ground on the tip lead) and its B bit as 1 (translated as -48V dc on the ring lead). However, measuring the voltage of the ring lead on the T1 line would not return -48V dc , since actual electrical impulses are not being sent.

Call operation will be described by categorizing the operation into the following main states:

- Idle (on-hook)
- Incoming calls
- Outgoing calls
- Calls disconnected by the CO
- Calls disconnected by the telephone

Loop Start Mode

In Loop Start mode , the A and B bits have the following meaning:

Transmit from LTI: A bit = 0 (tip ground on)
B bit = Ringing (0=on, 1=off)

Receive to LTI: A bit = Loop (0=open, 1=closed)
B bit = 1 (no ring ground)

When a T1 channel is idle, the line-side T1 card simulates a ground on the tip lead and -48Vdc on the ring lead to the terminal equipment by setting its transmit A bit to 0 and transmit B bit to 1. Accordingly, an on-hook channel on the terminal equipment simulates an open loop toward the line-side T1 card, causing the line-side T1 card's receive bits to be set to A = 0 and receive B = 1.

Incoming calls

Incoming calls to terminal equipment attached to the line-side T1 card can originate either from stations that are local (served by the Meridian 1 PBX), or remote (served through the PSTN). To provide the ringing signal to a telephone the line-side T1 card simulates an additional 90V on the ring lead to the terminal equipment by alternating the transmit B bit between 0 and 1 (0 during ring on, 1 during ring off). When an incoming call is answered by the terminal equipment going off-hook, the terminal equipment simulates tripping the ringing and shutting off ringing, causing the line-side T1 card's receive A bit to be changed from 0 to 1.

Outgoing calls

During outgoing calls from the terminal equipment, a channel is seized when the station goes off-hook. This simulates a low-resistance loop across the tip and ring leads toward the line-side T1 card, causing the line-side T1's receive A bit to be changed from 0 to 1. This bit change prepares the line-side T1 to receive digits. Outward address signaling is then applied from the terminal equipment in the form of DTMF tones or loop (interrupting) dial pulses that are signaled by the receive A bit pulsing between 1 and 0.

Call disconnect from far end (PSTN, private network or local Station)

When a call is in process, the central office may disconnect the call from the Meridian 1. If the line-side T1 port has been configured with the supervised analog line (SAL) feature, the line-side T1 card will respond to the distant end disconnect message by momentarily changing its transmit A bit to 1 and then returning it to 0. The duration of time that the transmit A bit remains at 1 before returning to 0 depends upon the setting that was configured using the SAL. If the terminal equipment is capable of detecting distant end disconnect, it will respond by changing the line-side T1 card's receive A bit to 0 (open loop). The call is now terminated and the interface is in the idle (on-hook) state.

For the line-side T1 card to support distant end disconnect in loop start mode, the following configuration parameters must exist:

- The Supervised Analog Line (SAL) feature must be configured for each line-side T1 port.

Note: By default, the SAL feature opens the tip side for 750 m/s in loop start operation. This is configurable in 10 m/s increments.

- For outgoing trunk calls, the trunk facility must provide far end disconnect supervision.
- In order to detect distant end disconnect for calls originating on the line-side T1 card, the battery reversal feature within the SAL software must be enabled. Enabling the battery reversal feature will not provide battery reversal indication but will only provide a momentary interruption of the tip ground by asserting the A bit to 1 for the specified duration.
- In order to detect distant end disconnect for calls terminating on the line-side T1 card, the hook flash feature within the SAL software must be enabled.
- In order to detect distant end disconnect for calls originating and terminating on the line-side T1 card, both the battery reversal and hook flash features must be enabled within the SAL software.

Call disconnect from line-side T1 terminal equipment

Alternatively, while a call is in process, the terminal equipment may disconnect by going on-hook. The terminal equipment detects no loop current and sends signaling to the line-side T1 card that causes its receive A bit to change from 1 to 0. The call is now released.

Table 3 outlines the line-side T1's A and B bit settings in each state of call processing.

Ground Start Mode

In ground start mode, the A and B bits have the following meaning:

Transmit from LTI: A bit = Tip ground (0=grounded, 1=not grounded)
B bit = Ringing (0=on, 1=off)

Receive to LTI: A bit = Loop (0=open, 1=closed)
B bit = Ring ground (0=grounded, 1=not grounded)

When a T1 channel is idle, the line-side T1 card simulates a ground on the tip lead and -48V dc on the ring lead to the terminal equipment by setting the transmit A bit to 1 and transmit B bit to 1. Accordingly, an on-hook telephone simulates an open loop toward the line-side T1 card, causing the line-side T1 card's receive bits to be set to A = 0 and B = 1.

Incoming Calls

Incoming calls to terminal equipment that is connected to the line-side T1 card can originate either from stations that are local (served by the Meridian 1 PBX), or remote (served through the public switched telephone network). To provide the ringing signal to the terminal equipment the line-side T1 card simulates the 90V ring signal on the ring lead by alternating the transmit B bit between 0 and 1 (0 during ring on, 1 during ring off), and ground on the tip lead by setting the transmit A bit to 0. When an incoming call is answered (by the terminal equipment going off-hook), the terminal equipment simulates tripping the ringing and shutting off ringing by causing the line-side T1's receive A bit to change from 0 to 1. The line-side T1 card responds to this message by simulating loop closure by holding the transmit B bit constant at 1.

Table 3
Loop Start Call Processing A/B Bit Settings

State	Transmit		Receive	
	A	B	A	B
Idle	0	1	0	1
Incoming Calls:				
• Idle	0	1	0	1
• Ringing is applied from line-side T1 card	0	1/0	0	1
• Terminal equipment goes off-hook	0	1/0	1	1
• Line-side T1 card stops ringing	0	1	1	1
Outgoing Calls:				
• Idle	0	1	0	1
• Terminal equipment goes off-hook	0	1	1	1
Call Disconnect from far end:				
• Steady state (call in progress)	0	1	1	1
• Far end disconnects by dropping loop current and line-side T1 card changes Transmit A bit to 1 momentarily.	1	1	1	1
• Terminal equipment responds causing Receive A bit to change to 0.	1	1	0	1
• Line-side T1 responds by changing its Transmit A bit to 0. Call is terminated and set to idle state.	0	1	0	1
Call disconnect from terminal equipment:				
• Steady state (call in progress)	0	1	1	1
• Terminal equipment goes on-hook causing the Receive A bit to change to 0. Call is terminated and set to idle state.	0	1	0	1

Outgoing Calls

During outgoing calls from the terminal equipment, a channel is seized when the terminal equipment goes off-hook, simulating a ground to the ring lead toward the line-side T1 card by causing the line-side T1's receive B bit to change from 1 to 0. In turn, the line-side T1 card simulates grounding its tip lead by changing the transmit A bit to 0. The terminal equipment responds to this message by removing the ring ground (line-side T1's receive B bit is changed to 1) and simulating open loop at the terminal equipment (line-side T1's receive A bit is changed to 0).

Call disconnect from far end (PSTN, private network or local station)

While a call is in process, the far end might disconnect the call. If the line-side T1 port has been configured with the Supervised Analog Line (SAL) feature, the line-side T1 will respond to the distant end disconnect message by opening tip ground. This causes the line-side T1 card to change the transmit A bit to 1. When the terminal equipment sees the transmit A bit go to 1, it responds by simulating open loop causing the line-side T1's receive A bit to change to 0. The call is terminated and the interface is once again in the idle condition.

For the line-side T1 card to support distant end disconnect in ground start mode, the following configuration parameters must exist:

- The Supervised Analog Line (SAL) feature must be configured for each line-side T1 port.

Note: By default, the SAL feature opens the tip side for 750 m/s in loop start operation. This is configurable in 10 m/s increments.

- In order to detect distant end disconnect for calls originating on the line-side T1 card, the "battery reversal" feature within the SAL software must be enabled. Enabling the "battery reversal" feature will not provide battery reversal indication when a call is answered; it will only provide battery reversal indication when a call is disconnected.

- In order to detect distant end disconnect for calls terminating on the line-side T1 card, the “hook flash” feature within the SAL software must be enabled.
- In order to detect distant end disconnect for calls originating and terminating on the line-side T1 card, both the “battery reversal” and “hook flash” features within the SAL software must be enabled.

Call disconnect from line-side T1 terminal equipment

Alternatively, while a call is in process, the terminal equipment may disconnect by going on-hook, causing the line-side T1’s receive A bit to change to 0. The line-side T1 card responds to this message by simulating the removal of ground from the tip by changing its transmit A bit to 1. The call is now terminated and the interface is once again in the idle condition.

Table 4 on page 41 outlines the line-side T1’s A and B bit settings in each state of call processing.

Ground Start Restrictions

If the line-side T1 card is used in ground start mode, certain restrictions should be considered. Because the Meridian 1 system treats the line-side T1 card as a standard loop start analog line card, the ground start operation of the line-side T1 card has operational limitations compared to typical ground start interface equipment relating to *start of dialing*, *distant end disconnect* and *glare potential*.

Distant end disconnect restrictions

If the SAL feature is not available in the Meridian 1 software, the line-side T1 card is not capable of indicating to the Customer Premise Equipment (CPE) when a call has been terminated by the distant end. In this case, the line-side T1 card will continue to provide a grounded tip indication (A=0) to the CPE until it detects an open loop indication (A=0) from the CPE, at which time it will provide an open tip indication (A=1). Therefore, without SAL software, the line-side T1 card is not capable of initiating the termination of a call to the CPE.

With the SAL software configured for each line-side T1 line, the line-side T1 card will provide an open tip indication to the CPE when it receives an indication of supervised analog line from the Meridian 1 system. This provides normal ground start protocol call termination.

Table 4
Ground Start Call Processing A/B Bit Settings

State	Transmit		Receive	
	A	B	A	B
Idle	1	1	0	1
Incoming Calls (to terminal equipment):				
• Idle	1	1	0	1
• Ringing is applied from line-side T1 card by simulating ground on tip lead and ringing on ring lead.	0	0/1	0	1
• Terminal equipment goes off-hook by simulating ground on tip lead and ringing on ring lead.	0	0/1	1	1
Outgoing Calls (from terminal equipment):				
• Idle	1	1	0	1
• Terminal equipment goes off-hook.	1	1	0	0
• The line-side T1 simulates grounding its tip lead	0	1	0	0
• Terminal equipment opens ring ground and closes loop	0	1	1	1
Call Disconnect from far end:				
• Steady state (call in progress)	0	1	1	1
• The line-side T1 ungrounds tip	1	1	1	1
• Terminal equipment opens loop current	1	1	0	1
Call disconnect from terminal equipment:				
• Steady state (call in progress)	0	1	1	1
• Terminal equipment goes open loop current	0	1	0	1
• Line-side T1 card opens tip ground	1	1	0	1

Glare restrictions

In telephone lines or trunks, glare occurs when a call origination attempt results in the answering of a terminating call that is being presented by the far end simultaneously with the call origination attempt by the near end.

The line-side T1 detects presentation of a terminating call (outgoing to line-side T1 terminal equipment) by detecting ringing voltage. If application of the ringing voltage is delayed due to traffic volume and ringing generator capacity overload, the line-side T1 ground start operation cannot connect the tip side to ground to indicate the line has been seized by the Meridian 1.

In ground start mode, glare conditions need to be considered if both incoming and outgoing calls to the Customer Premise Equipment (CPE) are going to be encountered. If both the Meridian 1 and the CPE simultaneously attempt to use a line-side T1 line, the Meridian 1 will complete the call termination. It does not back down and allow the CPE to complete the call origination, as in normal ground start operation.

If both incoming and outgoing calls are to be handled through the line-side T1 interface, separate channels should be configured in the Meridian 1 system and the CPE for each call direction. This eliminates the possibility of glare conditions on call origination.

Voice frequency audio level

The digital pad for line-side T1 card audio level is fixed for all types of call connection (0 dB insertion loss in both directions), and differs from the Meridian 1 analog line. Audio level adjustments, if required, must be made in the line-side T1 terminal equipment.

Off-premise line protection

Off-premise applications are installations where the telephone lines are extended outside the building where the PBX system is housed, but the lines are not connected to public access facilities. This application is commonly referred to as a “campus installation.”

In off-premise applications, special protection devices and grounding are required to protect PBX and telephone components from any abnormal conditions, such as lightning strikes and power line crosses.

The NT1R20 Off-Premise Station Line Card has built-in protection against lightning strikes and power line crosses. These should be the preferred cards for an off-premise application. Other cards can be used when external line protectors are installed.

When using the line-side T1 card for an off-premise or network application, external line protectors must be installed. Install an isolated type channel service unit (CSU) as part of the terminal equipment, to provide the necessary isolation and outside line protection. The CSU should be an FCC part 68 or CSA certified unit.

Line protectors

Line protectors are voltage-absorbing devices that are installed at the cross-connect terminals at both the main building and the remote building. The use of line protectors will ensure that system and telephone components are not damaged from accidental voltages that are within the limit of the capacity of the protection device. Absolute protection from lightning strikes and other stray voltages cannot be guaranteed, but the use of line protection devices significantly reduces the possibility of damage.

Nortel Networks has tested line protection devices from three manufacturers. See Table 5 on page 44. Each manufacturer offers devices for protection of digital as well as analog telephone lines.

Table 5
Line protection device ordering information

Device order code		Manufacturer
Analog Line	Digital Line	
UP2S-235	UP2S-75	ITW Linx Communications 201 Scott Street Elk Grove Village, IL 60007 (708) 952-8844 or (800) 336-5469
6AP	6DP	Oneac Corporation 27944 North Bradley Road Libertyville, IL 60048-9700 (800) 553-7166 or (800) 327-8801 x555
ESP-200	ESP-050	EDCO Inc. of Florida 1805 N.E. 19th Avenue P.O. Box 1778 Ocala, FL 34478 (904) 732-3029 or (800) 648-4076

These devices are compatible with 66 type M1-50 split blocks or equivalent. Consult the device manufacturer if more specific compatibility information is required.

Line protection grounding

In conjunction with line protectors, proper system (PBX) grounding is essential to minimize equipment damage. Nortel Networks recommends following the grounding connection requirements as described in *System Installation Procedures* (553-3001-210). This requirement includes connecting the ground for the protection devices to the approved building earth ground reference. Any variances to these grounding requirements could limit the functionality of the protection device.

Line and telephone components

Because testing of the line protectors was limited to the line cards and telephones shown below, only these components should be used for off-premise installations.

Telephones

- Meridian Modular Telephones (digital)
- Meridian Digital Telephones
- Standard analog (500/2500-type) telephones

Line Cards

- NT1R20 Off-Premise Station Line Card
- NT8D02 Digital Line Card
- NT8D03 Analog Line Card
- NT8D09 Analog Line Card with Message Waiting

NT1R20 Off-Premise Station Analog Line Card

Contents

This section contains information on the following topics:

Introduction	48
Physical description	48
Functional description	51
Card interfaces	52
Card functions	52
Line interface units	52
Card control functions	52
Circuit power	53
Electrical specifications	54
Analog line interface	54
Power requirements	55
Foreign and surge voltage protection	55
Ringer limitations	55
Environmental specifications	56
Connector pin assignments	57
Configuring the OPS analog line card	59
Jumper strap settings	59
Software service changes	59
Port-to-port loss configuration	62
Applications	63
Off-premise station application	63

Other applications	63
Transmission considerations	65

Reference list

The following are the references in this section:

- *Summary of Transmission Parameters* (553-2201-182)
- *System Installation Procedures* (553-3001-210)
- *Software Input/Output Guide Administration* (553-3001-311)

Introduction

The NT1R20 Off-Premise Station (OPS) Analog Line Card provides eight full duplex analog telephone line interfaces. Each interface provides the external line connection with secondary hazard and surge (lightening) protection. Each line interface is independently configured by software control in the Analog (500/2500-type) Telephone Administration program LD 10.

The NT1R20 card provides:

- line supervision
- hookflash
- battery reversal

Physical description

The OPS analog line card mounts in any IPE slot. The line interface and common multiplexing circuitry is mounted on a 31.75 cm by 25.40 cm (12.5 in. by 10 in.) printed circuit board.

The OPS analog line card connects to the IPE backplane through a 160-pin connector shroud. The backplane is cabled to the input/output (I/O) panel on the rear of the module, which is then connected to the Main Distribution Frame (MDF) by 25-pair cables. Telephone lines from station equipment cross connect to the OPS analog line card at the MDF using a wiring plan similar to that of trunk cards. See *System Installation Procedures* (553-3001-210) for termination and cross-connect information.

The faceplate of the card is equipped with a red LED. See Figure 10 on page 50. When an OPS analog line card is installed, the LED remains lit for two to five seconds while the self-test runs. If the self-test completes successfully, the LED flashes three times and remains lit. When the card is configured and enabled in software; then the LED goes out. If the LED continues to flash or remains weakly lit, replace the card.

Figure 10
OPS analog line card – faceplate

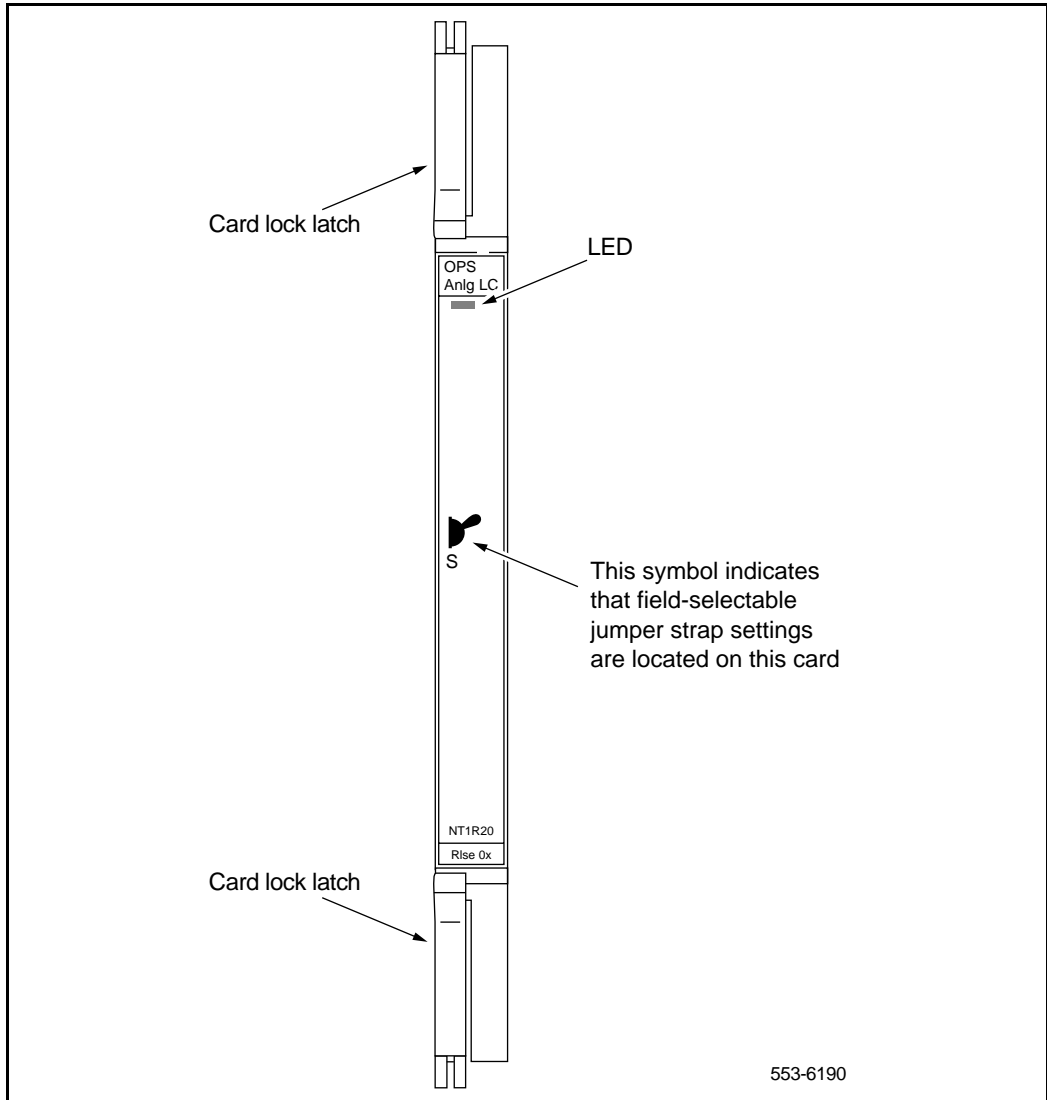

553-6190

Functional description

Figure 11 shows a block diagram of the major functions contained on the OPS analog line card. Each of these functions are described on the following pages.

Figure 11
OPS analog line card – block diagram

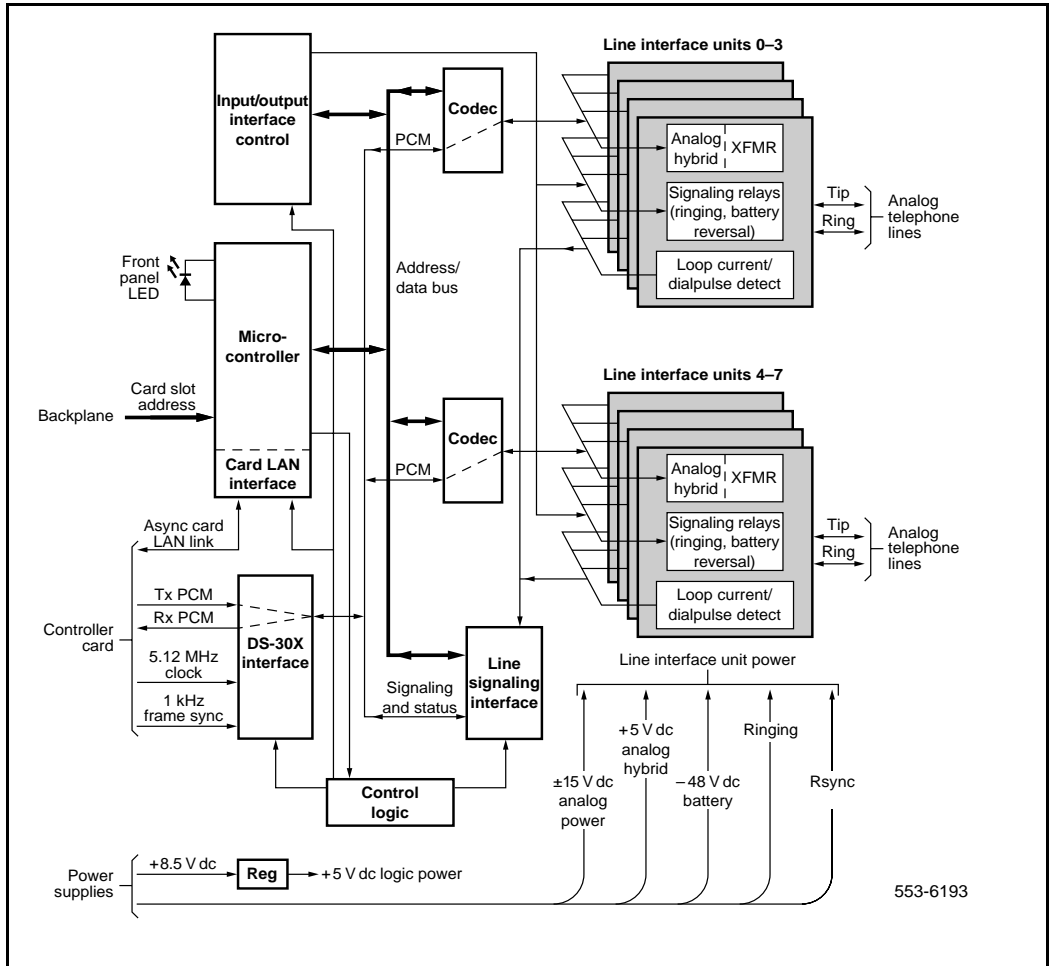

Card interfaces

The OPS analog line card passes voice and signaling data over DS-30X loops and maintenance data over the card LAN link. See “Intelligent peripheral equipment line cards” on page 14 for more details.

Card functions

Line interface units

The OPS analog line card contains eight identical and independently configurable interface units. Relays are provided in each unit to apply ringing onto the line. Signal detection circuits monitor on-hook/off-hook signaling. Two CODECs are provided for performing A/D and D/A conversion of line analog voiceband signals to digital PCM signals.

Each CODEC supports four line interface units and contains switchable pads for control of transmission loss on a per unit basis. The following features are common to all units on the card:

- OPS or ONS (On-Premise Station) service configurable on a per unit basis
- terminating impedance (600 or 900 ohm) selectable on a per unit basis
- standard or complex balance impedance (600 or 900 ohm or 3COM1 or 3COM2) selectable on a per unit basis
- loopback of PCM signals over DS-30X network loop for diagnostic purposes

Card control functions

Control functions are provided by a microcontroller, a Card LAN link, and signaling and control circuits on the OPS analog line card.

Microcontroller

The OPS analog line card contains a microcontroller that controls the internal operation of the card and the serial card LAN link to the controller card. The microcontroller controls the following:

- reporting to the CE CPU through the card LAN link:
 - card identification (card type, vintage, and serial number)
 - firmware version

- self-test status
- programmed configuration status
- receipt and implementation of card configuration:
 - programming of the CODECs
 - enabling/disabling of individual units or entire card
 - programming of input/output interface control circuits for administration of line interface unit operation
 - enabling/disabling of an interrupted dial tone to indicate call waiting
 - maintenance diagnostics
 - transmission loss levels

Card LAN interface

Maintenance data is exchanged with the Common Equipment CPU over a dedicated asynchronous serial network called the Card LAN link. The Card LAN link is described in the section “Intelligent peripheral equipment” on page 19.

The OPS analog line card has the capability of providing an interrupted dial tone to indicate that a message is waiting or that call forwarding is enabled. The line card (optionally) receives messages stating that these conditions exist over the Card LAN Interface and interrupts the dial tone when either of these conditions are detected.

Signaling and control

The signaling and control portion of the card provides circuits that establish, supervise, and take down call connections. These circuits work with the system CPU to operate the line interface circuits during calls. The circuits receive outgoing call signaling messages from the CPU and return incoming call status information over the DS-30X network loop.

Circuit power

The +8.5 V dc input is regulated down to +5 V dc for use by the digital logic circuits. All other power to the card is used by the line interface circuits. The ± 15.0 V dc inputs to the card are used to power the analog circuits. The +5 V dc from the module power supply is used for the analog hybrid. The

–48.0 V dc input is for the telephone battery. Ringing power for telephones is 86 Vrms ac at 20 Hz on –48 V dc. The Rsync signal is used to switch the 20 Hz ringing on and off at the zero cross-over point to lengthen the life of the switching circuits.

Electrical specifications

This section lists the electrical characteristics of the OPS analog line card.

Analog line interface

Table 6 lists the electrical characteristics of OPS analog line card line interface units.

Table 6
OPS analog line card – electrical characteristics

Characteristic	Specification
Terminal impedance (TIMP)	600 or 900 ohms
Balance impedance (BIMP)	600 or 900 ohms, 3COM, or 3CM2
DC signaling loop length (max)	2300 ohm loop (including resistance of telephone) with nominal battery of –48 V dc
Battery supply voltage	–42 to –52.5 V dc
Minimum detected loop current	16 mA
Ground potential difference	± 3 V
Line leakage	≥ 30k ohms, tip-to-ring, tip-to-ground, ring-to-ground
AC induction rejection	10 V rms, tip-to-ring, tip-to-ground, ring-to-ground

Power requirements

Table 7 shows the maximum power consumed by the card from each system power supply.

Table 7
OPS analog line card – power requirements

Voltage	Tolerance	Current (max.)
±15.0 V dc	± 5%	150 mA
+8.5 V dc	± 2%	200 mA
+5.0 V dc	± 5%	100 mA
–48.0 V dc	± 5%	350 mA

Foreign and surge voltage protection

The OPS analog line card meets UL-1489 and CS03 over-voltage (power cross) specifications and FCC Part 68 requirements for hazardous and surge voltage limits.

Ringer limitations

The OPS line card supports up to three NE-C4A (3 REN) ringers on each line for either ONS or OPS applications. See Table 8 on page 56.

Table 8
OPS analog line card – ringer limitations

ONS Loop Range	Maximum Number of Ringers (REN)
0–10 ohms	3
> 10–460 ohms	2

OPS Loop Range	Maximum Number of Ringers (REN)
0 – 10 ohms	3
> 10 – 900 ohms	2
> 900 – 2300 ohms	1

Environmental specifications

Table 9 shows the environmental specifications of the card.

Table 9
OPS analog line card – environmental specifications

Parameter	Specifications
Operating temperature	0° to +60° C (+32 to +140° F), ambient
Operating humidity	5 to 95% RH (non-condensing)
Storage temperature	–40° to +70° C (–40° to +158° F)

Connector pin assignments

The OPS analog line card brings the eight analog telephone lines to the IPE backplane through a 160-pin connector shroud. The backplane is cabled to the input/output (I/O) panel on the rear of the module, which is then connected to the Main Distribution Frame (MDF) by 25-pair cables.

Telephone lines from station equipment cross connect to the OPS analog line card at the MDF using a wiring plan similar to that used for trunk cards. A typical connection example is shown in Figure 12 on page 58, and a list of the connections to the analog line card is shown in Table 10. See *System Installation Procedures (553-3001-210)* for more detailed I/O panel connector information and wire assignments for each tip/ring pair.

Table 10
OPS analog line card – backplane pinouts

Backplane Connector Pin	Signal	Backplane Connector Pin	Signal
12A	Unit 0, Ring	12B	Unit 0, Tip
13A	Unit 1, Ring	13B	Unit 1, Tip
14A	Unit 2, Ring	14B	Unit 2, Tip
15A	Unit 3, Ring	15B	Unit 3, Tip
16A	Unit 4, Ring	16B	Unit 4, Tip
17A	Unit 5, Ring	17B	Unit 5, Tip
18A	Unit 6, Ring	18B	Unit 6, Tip
19A	Unit 7, Ring	19B	Unit 7, Tip

Figure 12
OPS analog line card – typical cross connection example

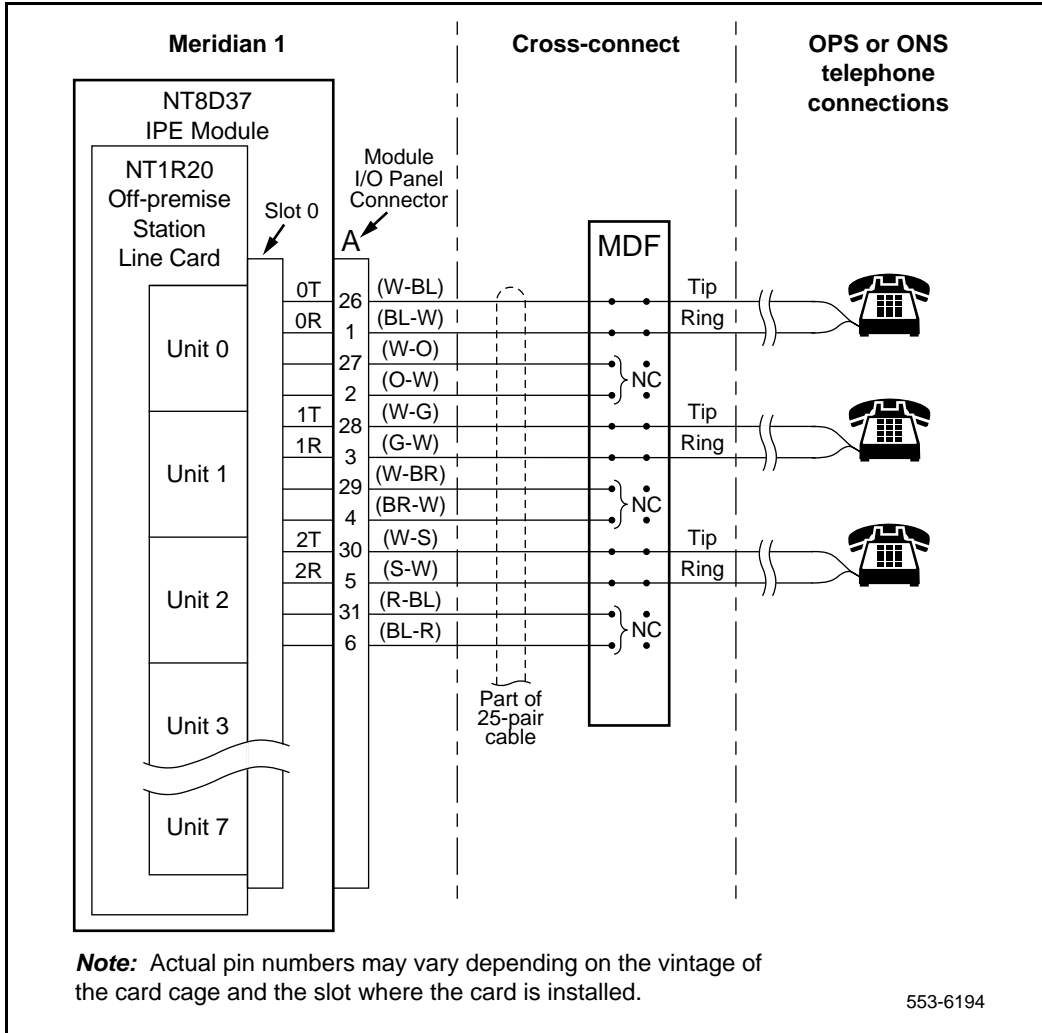

Configuring the OPS analog line card

The line type, terminating impedance, and balance network configuration for each unit on the card is selected by software service change entries at the system terminal and by jumper strap settings on the card.

Jumper strap settings

Each line interface unit on the card is equipped with two jumper blocks that are used to select the proper loop current depending upon loop length. See Table 11 on page 60. For units connected to loops of 460 to 2300 ohms, both jumper blocks for that unit must have jumper blocks installed. For loops that are 460 ohms or less, jumper blocks are not installed. Figure 13 on page 61 shows the location of the jumper blocks on the OPS analog line card.

Before the appropriate balance network can be selected, the loop length between the near-end (Meridian 1) and the far-end station must be known. To assist in determining loop length, Table 12 on page 62 shows some typical resistance and loss values for the most common cable lengths for comparison with values obtained from actual measurements.

Software service changes

Individual line interface units on the OPS analog line card are configured to either OPX (for OPS application) or ONP (for ONS application) Class-of-Service (CLS) using the Analog (500/2500-type) Telephone Administration program LD 10. See Table 11 on page 60.

LD 10 is also used to select unit terminating impedance and balance network impedance at the TIMP and BIMP prompts, respectively. The message waiting interrupted dial tone and call forward reminder tone features are enabled by entering data into the customer data block using LD 15.

See *Software Input/Output Guide Administration* (553-3001-311) for LD 10 and LD 15 service change instructions.

Table 11
OPS analog line card – configuration

Application	On-premise station (ONS)			Off-premise station (OPS)												
Class of Service (CLS) (Note 1)	ONP			OPX												
Loop resistance (ohms)	0–460			0–2300 (Note 2)												
Jumper strap setting (Note 6)	Both JX.0 and JX.1 off			Both JX.0 and JX.1 off		Both JX.0 and JX.1 on										
Loop loss (dB) (Note 3)	0–1.5	>0–3.0	>2.5–3.0	0–1.5	>1.5–2.5	>2.5–4.5	>4.5–15									
TIMP (Notes 1, 4)	600 ohms	600 ohms	600 ohms	600 ohms	600 ohms	600 ohms	600 ohms									
BIMP (Notes 1, 4)	600 ohms	3COM	3CM2	600 ohms	3COM	3CM2	3CM2									
Gain treatment (Note 5)	No						Yes									
<p>Note 1: Configured in the Analog (500/2500-type) Telephone Administration program LD 10.</p> <p>Note 2: The maximum signaling range supported by the OPS analog line card is 2300 ohms.</p> <p>Note 3: Loss of untreated (no gain devices) metallic line facility. Upper loss limits correspond to loop resistance ranges for 26 AWG wire.</p> <p>Note 4: The following are the default software impedance settings:</p> <table style="margin-left: 40px;"> <thead> <tr> <th></th> <th><u>ONP CLS</u></th> <th><u>OPX CLS</u></th> </tr> </thead> <tbody> <tr> <td>Termination Impedance (TIMP):</td> <td>600 ohms</td> <td>600 ohms</td> </tr> <tr> <td>Balanced Impedance (BIMP):</td> <td>600 ohms</td> <td>3CM2</td> </tr> </tbody> </table> <p>Note 5: Gain treatment, such as a Voice Frequency Repeater (VFR) is required to limit the actual OPS loop loss to 4.5 dB, maximum. VFR treatment of metallic loops having untreated loss greater than 15 dB (equivalent to a maximum signaling range of 2300 ohms on 26 AWG wire) is not recommended.</p> <p>Note 6: Jumper strap settings JX.0 and JX.1 apply to all eight units; “X” indicates the unit number, 0 – 7. “Off” indicates that a jumper strap is not installed across both pins on a jumper block. Store unused straps on the OPS analog line card by installing them on a single jumper pin.</p>									<u>ONP CLS</u>	<u>OPX CLS</u>	Termination Impedance (TIMP):	600 ohms	600 ohms	Balanced Impedance (BIMP):	600 ohms	3CM2
	<u>ONP CLS</u>	<u>OPX CLS</u>														
Termination Impedance (TIMP):	600 ohms	600 ohms														
Balanced Impedance (BIMP):	600 ohms	3CM2														

Figure 13
OPS analog line card – jumper block locations

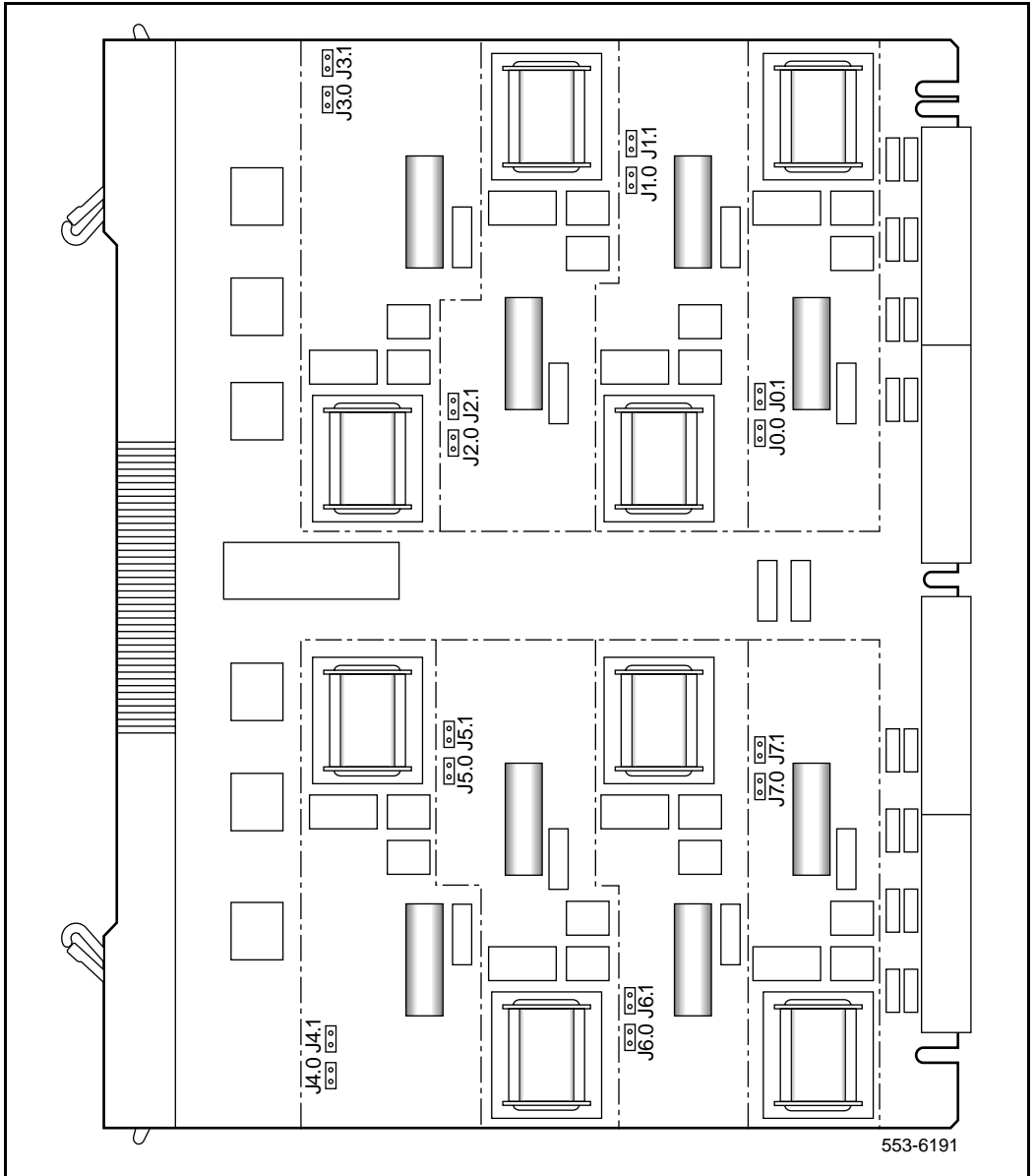

Port-to-port loss configuration

The OPS analog line card provides transmission loss switching for control of end-to-end connection loss. Control of loss is a major element in controlling transmission performance parameters such as received volume, echo, noise, and crosstalk. The loss plan for the OPS analog line card determines port-to-port loss for connections between an OPS analog line card unit (port) and other Meridian 1 IPE ports. LD 97 is used to configure the Meridian system for port-to-port loss.

See *Software Input/Output Guide Administration* (553-3001-311) for LD 97 service change instructions.

The transmission properties of each line unit are characterized by the OPX or ONP class-of-service assigned in the Analog (500/2500-type) Telephone Administration program (LD 10). A complete loss plan is given in *Summary of Transmission Parameters* (553-2201-182) where the appropriate port-to-port electrical loss may be determined for connections between any two Meridian 1 ports (lines, analog trunks, or digital trunks).

Table 12
OPS analog line card – cable loop resistance and loss

Cable length	Cable loop loss (dB) (non-loaded at 1kHz)			Cable loop resistance (ohms)		
	26 AWG	24 AWG	22 AWG	26 AWG	24 AWG	22 AWG
847 m (2800 ft)	1.5	1.2	0.9	231.4	144.2	90
1411 m (4600 ft)	2.5	2	1.6	385.6	240.3	150
1694 m (5600 ft)	3	2.4	1.9	462.8	288.3	180
2541 m (8300 ft)	4.5	3.7	2.8	694.2	432.5	270
8469 m (27800 ft)	15	12.2	9.4	2313.9	1441.7	900

Applications

Off-premise station application

The NT1R20 OPS Analog Line Card is designed primarily to provide an interface for Meridian 1 off-premise station lines. An OPS line serves a terminal – usually a telephone – remote from the PBX either within the same serving area as the local office or through a distant office. The line is not switched at these offices; however, depending on the facilities used, the local office serving the OPS station may provide line functions such as battery and ringing. Facilities are generally provided by the local exchange carrier (OPS pairs are usually in the same cable as the PBX-CO trunks). The traditional OPS scenario configuration is shown in Figure 14 on page 64.

Note: OPS service should not be confused with Off-Premise EXtension (OPX) service. OPX service is the provision of an extension to a main subscriber loop bridged onto the loop at the serving CO or PBX. (OPX as used to denote off-premise extension service should not be confused with the OPX class-of-service assigned in the Analog (500/2500-type) Telephone Administration program LD 10.)

Other applications

The operating range and built-in protection provisions of the OPS analog line card make it suitable for applications that are variants on the traditional configuration shown in Figure 14 on page 64. Examples of such applications include:

- a PBX in a central building serving stations in other buildings in the vicinity, such as in an industrial park, often called a campus environment. Facilities may be provided by the local exchange carrier or can be privately owned. Protection could be required.
- termination to other than a telephone, such as a fax machine
- individual circuits on the OPS analog line card can also be configured as ONS ports in LD 10:
 - to have ONS service with hazardous and surge voltage protection (not available on other Meridian 1 analog line cards)
 - to use otherwise idle OPS analog line card ports

Figure 14
Traditional OPS application configuration

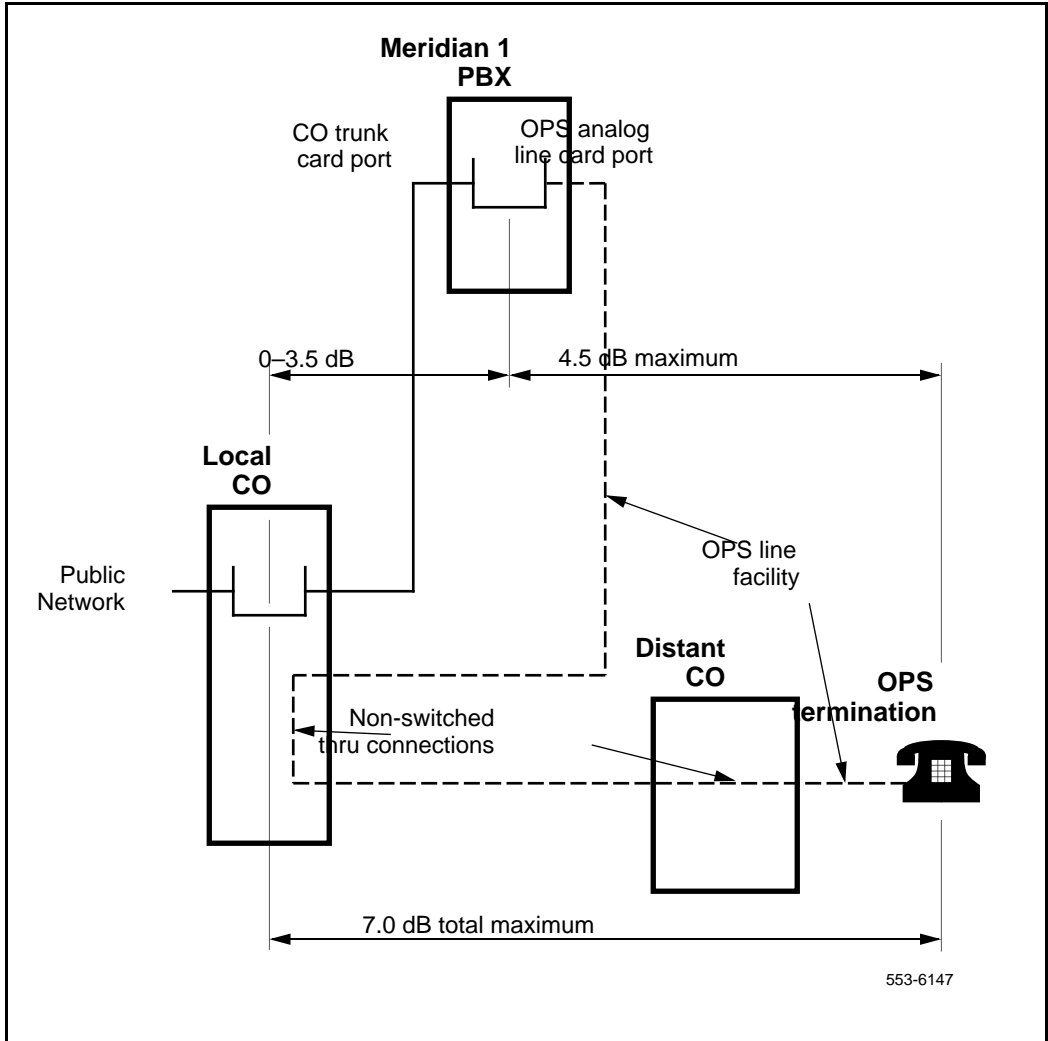

Transmission considerations

The transmission performance of OPS lines depends on the following factors:

- the Meridian 1 port-to-port loss for connections between OPS ports and other Meridian 1 ports
- the transmission parameters of the facilities between the Meridian 1 OPS port and the off-premise station or termination
- the electrical and acoustic transmission characteristics of the termination

These factors must be considered when planning applications using the OPS analog line card. They are important if considering configurations other than the traditional OPS application shown in Figure 14 on page 64.

The following information provides basic transmission planning guidelines for various OPS applications.

Port-to-port loss

Loss is inserted between OPS analog line card ports and other Meridian 1 ports in accordance with the Meridian 1 loss plan. This plan determines the port-to-port loss for each call.

When a port is configured for CLS OPS, loss is programmed into the OPS analog line card on a call-by-call basis. When configured for CLS ONS, an OPS analog line card port is programmed to a value that is fixed for all calls. The loss in the other port involved in the call can vary on a call-by-call basis to achieve the total loss scheduled by the plan. *Summary of Transmission Parameters* (553-2201-182) shows the specific loss for each possible port-to-port combination.

For satisfactory transmission performance, particularly on connections between the public network and an OPS termination, it is recommended that facilities conform to the following:

- Total 1 kHz loss from the local serving CO to the OPS terminal should not exceed 7.0 dB. Of that total, the loss in the facility between the PBX and the terminal should not exceed 4.5 dB. See Figure 14 on page 64.

The following requirements are based on historic Inserted Connection Loss (ICL) objectives:

- PBX – CO trunk: 5 dB with gain; 0–4.0 dB without gain

— OPS line: 4.0 dB with gain; 0–4.5 dB without gain

In recent times economic and technological considerations have led to modifications of these historic objectives. However, the loss provisions in the PBX for OPS are constrained by regulatory requirements as well as industry standards; they are not designed to compensate for modified ICL designs in the connecting facilities.

- Nortel Networks recommends that the attenuation distortion (frequency response) of the OPS facility be within ± 3.0 dB over the frequency range from 300 to 3000 Hz. It is desirable that this bandwidth extend from 200 to 3200 Hz.
- The terminating impedance of the facility at the OPS port should approximate that of 600 ohms cable.

If the OPS line facility loss is greater than 4.5 dB but does not exceed 15 dB, line treatment using a switched-gain Voice Frequency Repeater (VFR) will extend the voice range.

The overall range achievable on an OPS line facility is limited by the signaling range (2300 ohm loop including telephone resistance). Signaling range is unaffected by gain treatment; thus, gain treatment can be used to extend the voice range to the limit of the signaling range. For example, on 26 AWG wire, the signaling range of 2300 ohms corresponds to an untreated metallic loop loss of 15 dB. Gain treatment (such as a VFR) with 10.5 dB of gain would maintain the OPS service loss objective of 4.5 dB while extending the voice range to the full limit of the signaling range:

$$\begin{array}{rcl} & 15.0 \text{ dB} & \text{(loss corresponding to the maximum signaling range)} \\ - & 4.5 \text{ dB} & \text{(OPS service loss objective)} \\ \hline = & 10.5 \text{ dB} & \text{(required gain treatment)} \end{array}$$

The use of dial long line units to extend the signaling range of OPS analog line cards beyond 15 dB is not recommended.

Termination transmission characteristics

The loss plan for OPS connections is designed so that a connection with an OPS termination provides satisfactory end-to-end listener volume when the OPS termination is a standard telephone. The listener volume at the distant end depends on the OPS termination transmit loudness characteristics; the volume at the OPS termination end depends on the OPS termination receive loudness characteristics.

A feature of many (though not all) standard telephones is that the loudness increases with decreased current. Thus, as the line (Meridian 1 to OPS termination) facility gets longer and lossier, the increased loudness of the telephone somewhat compensates for the higher loss, assuming direct current feed from the PBX with constant voltage at the feeding bridge. However, this compensation is not available when:

- the termination is a non-compensating telephone
- the OPS port is served by a line card using a constant-current feeding bridge
- the OPS termination is to telephones behind a local switch providing local current feed, such as a fax machine

OPS line terminations with loudness characteristics designed for other applications can also impact transmission performance. For example, wireless portables loudness characteristics are selected for connections to switching systems for wireless communication systems; if used in an OPS arrangement without consideration for these characteristics, the result could be a significant deviation from optimum loudness performance.

NT5D11 Line-side T1 Interface Card

Contents

This section contains information on the following topics:

Introduction	70
Physical description	70
Card connections	71
Faceplate	71
Functional description	75
Overview	75
Card interfaces	77
T1 interface circuit	77
Signaling and control	77
Card control functions	77
Electrical specifications	80
T1 channel specifications	80
Power requirements	80
Foreign and surge voltage protections	81
Environmental specifications	81
Installation and Configuration	81
Dip switch settings	82
Installation	88
Cabling the line-side T1 card	90
Terminal configuration	98
Software configuration	98
Man-Machine T1 maintenance interface software	100
Description	100
Login and Password	103

Basic commands	104
Configuring parameters	107
Alarm operation and reporting	111
Performance counters and reporting	114
Testing	116
Applications	119

Reference list

The following references are found in this section:

- *Administration* (553-3001-311)
- *System Installation Procedures* (553-3001-210)

Introduction

The NT5D11 Line-side T1 Interface Card is an IPE line card that can be installed in the NT8D37 IPE module. Up to eight cards can be installed.

The line-side T1 card interfaces one T1 line, carrying 24 channels, to the Meridian 1 switch. This card occupies two card slots in the IPE shelf, utilizing 16 channels on slot 1 and 8 channels on slot 2. The line-side T1 card emulates an analog line card to the Meridian 1 software; therefore, each channel is independently configured by software control in the Analog (500/2500-type) Telephone Administration program LD 10. The line-side T1 card is equipped with a Man-Machine Interface (MMI) maintenance program that provides diagnostic information regarding the status of the T1 link.

Physical description

The line-side T1 card mounts into any two consecutive IPE slots. The card consists of a motherboard and a daughterboard. The motherboard circuitry is contained on a standard 31.75 by 25.40 cm. (12.5 by 10.0 in) printed circuit board. The daughterboard is contained on a 5.08 by 15.24 cm (2.0 by 6.0 in) printed circuit board and mounts to the motherboard on six standoffs.

Card connections

The line-side T1 card uses the NT8D81AA Tip and Ring cable to connect from the IPE backplane to the 25-pair amphenol connector on the IPE I/O input/output (I/O) panel. The I/O panel connector then connects directly to a T1 line, external alarm, and an MMI terminal or modem using the NT5D13AA Line-side T1 I/O cable available from Nortel Networks.

Faceplate

The faceplate of the card is twice as wide as the other standard analog and digital line cards, and occupies two card slots. It comes equipped with four LED indicators. See Figure 15 on page 72.

The LEDs provide status indications on the operations as described in Table 13.

Table 13
Line-side T1 card LED operation

LED	OPERATION
STATUS	Line card
RED ALARM	T1 near end
YELLOW ALARM	T1 far end
MAINT	Maintenance

The **STATUS** LED indicates that the line-side T1 card has successfully passed its self test, and is functional. When the card is installed, this LED remains lit for two to five seconds as the self-test runs. If the self-test completes successfully, the LED flashes three times and remains lit. When the card is configured and enabled in software, the LED goes out. If the LED flashes continuously, or remains weakly lit, replace the card.

Figure 15
Line-side T1 card – faceplate

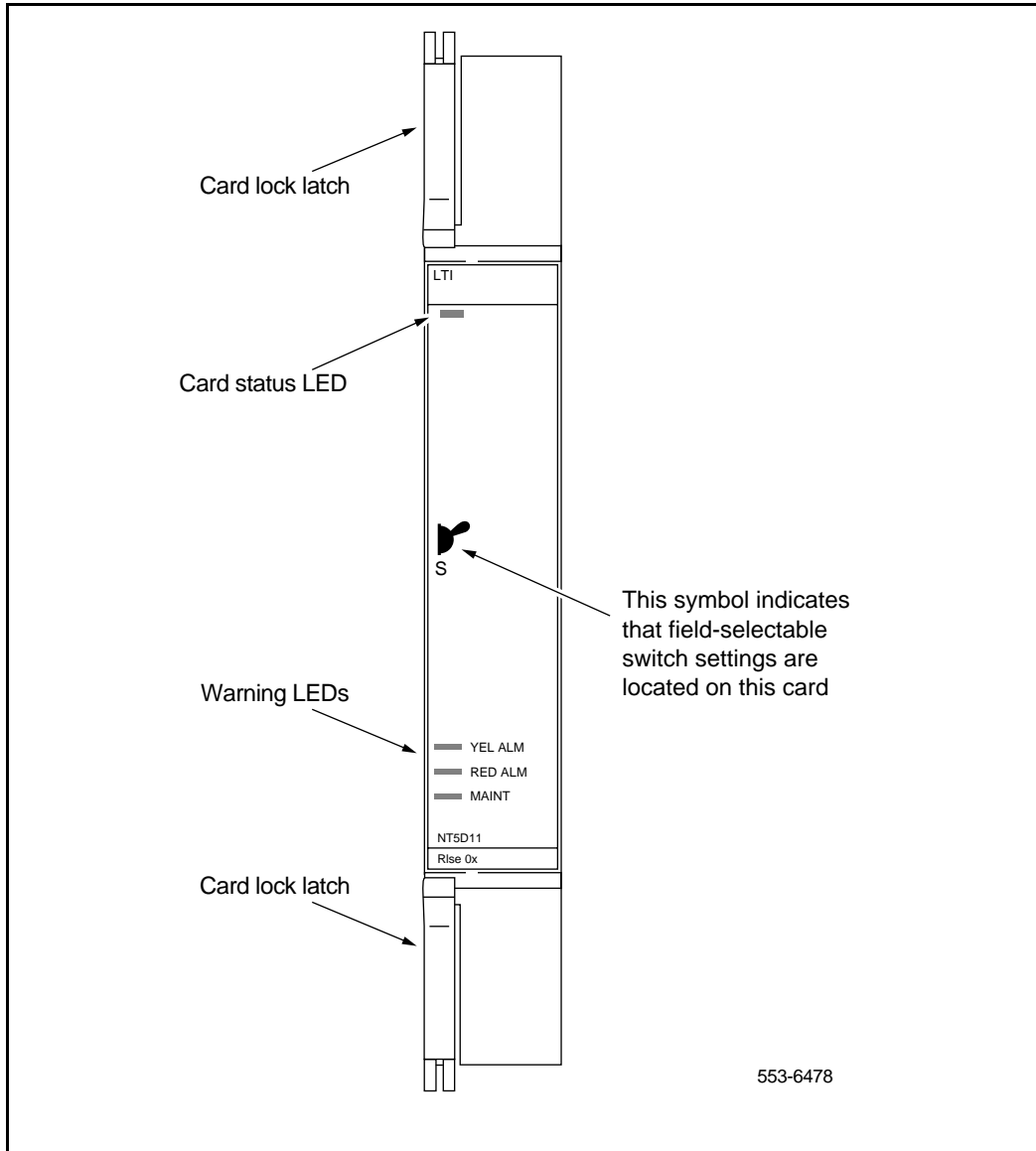

553-6478

Note: Note: The STATUS LED indicates the enabled/disabled status of both card slots of the line-side T1 card simultaneously. To properly enable the card, both the motherboard and the daughterboard slots must be enabled. The STATUS LED will turn off as soon as either one of the line-side T1 card slots have been enabled. No LED operation will be observed when the second card slot is enabled. To properly disable the card, both card slots must be disabled. The LED will not turn on until both card slots have been disabled.

The **RED ALARM** LED indicates that the line-side T1 card has detected an alarm condition from the T1 link. Alarm conditions can include such conditions as not receiving a signal or the signal has exceeded bit error thresholds or frame slip thresholds. See “Man-Machine T1 maintenance interface software” on page 100 for information on T1 link maintenance.

If one of these alarm conditions is detected, this red LED will light. Yellow alarm indication is sent to the far-end as long as the near-end remains in a red alarm condition. Depending on how the Man-Machine Interface (MMI) is configured, this LED remains lit until the following actions occur:

- If the “Self-Clearing” function has been enabled in the MMI, the LED clears the alarm when the alarm condition is no longer detected. This is the factory default.
- If the “Self-Clearing” function has *not* been enabled or it has been subsequently disabled in the MMI, the LED will stay lit until the command “Clear Alarm” has been typed in the MMI, even though the carrier automatically returned to service when the alarm condition was no longer detected.

The **YELLOW ALARM** LED indicates that the line-side T1 card has detected a yellow alarm signal from the terminal equipment side of the T1 link. See the “Man-Machine T1 maintenance interface software” on page 100 for information on T1 link maintenance. If the terminal equipment detects a red alarm condition, such as not receiving a signal or the signal has exceeded bit error thresholds or frame slip thresholds, it can send a yellow alarm signal to the line-side T1 card, depending on whether or not the terminal equipment supports this feature. If a yellow alarm signal is detected, this LED will light.

The **MAINT** LED indicates if the line-side T1 card is fully operational because of certain maintenance commands being issued through the MMI. See “Man-Machine T1 maintenance interface software” on page 100 for information on T1 link maintenance. If the card detects that tests are being run or that alarms have been disabled through the MMI, this LED will light and will remain lit until these conditions are no longer detected, then it will turn off.

Functional description

Figure 16 shows a block diagram of the major functions contained on the line-side T1 card. Each of these functions is described on the following pages.

Figure 16
Line-side T1 card – block diagram

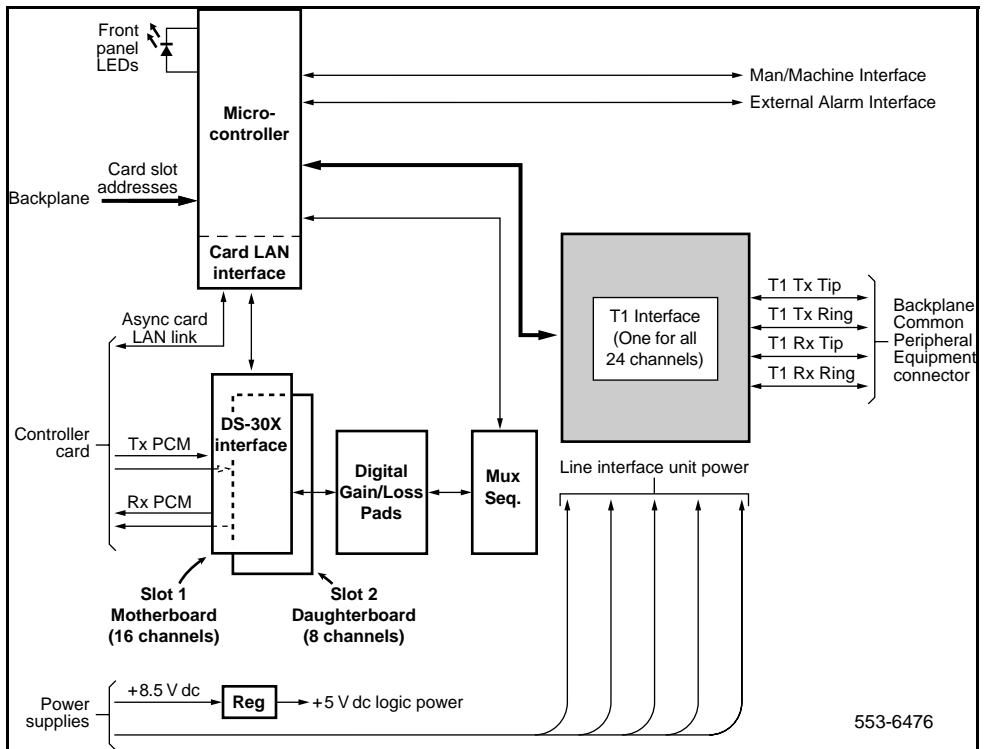

Overview

The line-side T1 card is an IPE line card that provides a cost-effective all-digital connection between T1 compatible terminal equipment (such as voice mail systems, voice response units, and trading turrets) and a Meridian 1 system. The terminal equipment is assured access to analog (500/2500-type) telephone type line functionality such as hook flash, SPRE codes and ringback tones generated from the Meridian 1. Usually, the

line-side T1 card eliminates the need for channel bank type equipment normally placed between the Meridian 1 and the terminal equipment. This provides a more robust and reliable end-to-end connection. The line-side T1 card supports line supervision features such as loop and ground start protocols. It can also be used in an off-premise arrangement where analog (500/2500-type) telephones are extended over T1 with the use of channel bank equipment.

The line-side T1 interface offers significant improvement over the previous alternatives. For example, if a digital trunk connection were used, such as with the DTI/PRI interface card, line-side functionality would not be supported. Previously, the only way to achieve the line-side functionality was to use analog ports and channel bank equipment. With the line-side T1 interface, a direct connection is provided between the Meridian 1 and the peripheral equipment. No channel bank equipment is required, resulting in a more robust and reliable connection.

The line-side T1 interface offers a number of benefits when used to connect a Meridian 1 to third-party applications equipment:

- It is a more cost-effective alternative for connection because it eliminates the need for expensive channel bank equipment.
- The line-side T1 supports powerful T1 monitoring and diagnostic capability.
- Overall costs for customer applications can also be reduced because the T1-compatible peripheral equipment is often more attractively priced than the analog-port alternatives.

The line-side T1 card is compatible with all IPE based systems and standard public or private DSX-1 type carrier facilities. Using A/B robbed bit signaling, it supports D4 or ESF channel framing formats as well as AMI or B8ZS coding. Because it uses standard PCM in standard T1 timeslots, existing T1 test equipment remains compatible for diagnostic and fault isolation purposes.

Card interfaces

The line-side T1 card passes voice and signaling data over DS-30X loops through the DS-30X Interfaces circuits and maintenance data over the card LAN link. These interfaces are discussed in detail in “Intelligent peripheral equipment” on page 19.

T1 interface circuit

The line-side T1 card contains one T1 line interface circuit that provides 24 individually configurable voice interfaces to one T1 link in 24 different time slots. The circuit demultiplexes the 2.56 Mbps DS-30X Tx signaling bitstreams from the DS-30X network loop and converts it into 1.544 MHz T1 Tx signaling bitstreams onto the T1 link. It also does the opposite, receiving Rx signaling bitstreams from the T1 link and transmitting Rx signaling bitstreams onto the DS-30X network loop.

The line interface circuit performs the following:

- Provides an industry standard DSX-1 (0 to 655 feet) interface.
- Converts DS-30X signaling protocol into FXO A and B robbed bit signaling protocol.
- Provides switch-selectable transmission and reception of T1 signaling messages over a T1 link in either loop or ground start mode.

Signaling and control

The line-side T1 card also contains signaling and control circuits that establish, supervise, and take down call connections. These circuits work with the system controller to operate the T1 line interface circuit during calls. The circuits receive outgoing call signaling messages from the controller and return incoming call status information to the controller over the DS-30X network loop.

Card control functions

Control functions are provided by a microcontroller and a Card LAN link on the line-side T1 card. A sanity timer is provided to automatically reset the card if the microcontroller stops functioning for any reason.

Microcontrollers

The line-side T1 card contains two microcontrollers that control the internal operation of the card and the serial card LAN link to the controller card. The microcontrollers control the following:

- reporting to the CE CPU through the card LAN link:
 - card identification (card type, vintage, serial number)
 - firmware version
 - self-test results
 - programmed unit parameter status

- receipt and implementation of card configuration:
 - control of the T1 line interfaces
 - enabling/disabling of individual units or entire card
 - programming of loop interface control circuits for administration of channel operation
 - maintenance diagnostics

- interface with the line card circuit:
 - converts on/off-hook, and ringer control messages from the DS-30X loop into A/B bit manipulations for each time slot in the T1 data stream, using robbed bit signaling.

- the front panel LED when the card is enabled or disabled by instructions from the NT8D01 controller card.

Card LAN interface

Maintenance data is exchanged with the Common Equipment CPU over a dedicated asynchronous serial network called the Card LAN link. The Card LAN link is described in “Card LAN link” on page 22.

Sanity timer

The line-side T1 card also contains a sanity timer that resets the microcontroller in the event of a loss of program control. If the timer is not properly serviced by the microcontroller, it times out and causes the microcontroller to be hardware reset. If the microcontroller loses control and fails to service the sanity timer at least once per second, the sanity timer will automatically reset the microcontroller, restoring program control.

Man-Machine Interface

The line-side T1 card provides an optional Man-Machine Interface (MMI) that is primarily used for T1 link performance monitoring and problem diagnosis. The MMI provides alarm notification, T1 link performance reporting and fault isolation testing. The interface is accessed through connections from the I/O panel to a terminal or modem. Multiple cards (up to 64) can be served through one MMI terminal or modem by cabling the cards together.

The MMI is an optional feature since all T1 configuration settings are performed through dip switch settings or preconfigured factory default settings. The man-machine interface is discussed fully in “Man-Machine T1 maintenance interface software” on page 100.

Electrical specifications

Table 14 provides a technical summary of the T1 line interfaces, and Table 15 lists the maximum power consumed by the card.

T1 channel specifications

Table 14 provides specifications for the 24 T1 channels. Each characteristic is set by dip switches. See “Installation and Configuration” on page 81 for the corresponding dip switch settings.

Table 14
Line-side T1 card – line interface unit electrical characteristics

Characteristics	Description
Framing	ESF or D4
Coding	AMI or B8ZS
Signaling	Loop or ground start A/B robbed-bit
Distance to Customer Premise Equipment (CPE) or Channel Service Unit	0-199.6 meters (0-655 feet)

Power requirements

The line-side T1 card requires +15 V, -15 V, and +5 V from the backplane. One NT8D06 Peripheral Equipment Power Supply ac or NT6D40 Peripheral Equipment Power Supply dc can supply power to a maximum of eight line-side T1 cards.

Table 15
Line-side T1 card – power required

Voltage	Current (max.)
+ 5.0 V dc	1.6 Amp
+15.0 V dc	150 mA.
-15.0 V dc	150 mA.

Foreign and surge voltage protections

In-circuit protection against power line crosses or lightning is not provided on the line-side T1 card. It does have protection against accidental shorts to –52 V dc analog lines.

When the card is used to service off-premise terminal equipment through the public telephone network, install a Channel Service Unit (CSU) as part of the terminal equipment to provide external line protection.

Environmental specifications

Table 16 lists the environmental specifications of the line-side T1 card.

Table 16
Line-side T1 card – environmental specifications

Parameter	Specifications
Operating temperature-normal	15° to +30° C (+59° to 86°F), ambient
Operating temperature-short term	10° to +45° C (+50° to 113°F), ambient
Operating humidity-normal	20% to 55% RH (non-condensing)
Operating humidity-short term	20% to 80% RH (non-condensing)
Storage temperature	–50° to +70° C (–58° to 158°F), ambient
Storage humidity	5% to 95% RH (non-condensing)

Installation and Configuration

Installation and configuration of the line-side T1 card consists of six basic steps:

- 1** Configure the dip switches on the line-side T1 card for the environment.
- 2** Install the line-side T1 card into the selected card slots in the IPE shelf.
- 3** Cable from the I/O panel to the Customer Premise Equipment (CPE) or CSU, MMI terminal or modem (optional), external alarm (optional), and other line-side T1 cards for daisy chaining use of MMI terminal (optional).
- 4** Configure the MMI terminal.

- 5 Configure the line-side T1 card through the Meridian 1 software and verify self-test results.
- 6 Verify initial T1 operation and configure MMI (optional).

Steps 1-5 are explained in this section. Step 6 is covered in “Man-Machine T1 maintenance interface software” on page 100.

Dip switch settings

Begin the installation and configuration of the line-side T1 card by selecting the proper dip switch settings for the environment. The line-side T1 card contains two dip switches, each containing eight switch positions. They are located in the upper right corner of the motherboard circuit card as shown in Figure 17 on page 83. The settings for these switches are shown in Tables 17 through 20.

When the line-side T1 card is oriented as shown in Figure 17, the dip switches are ON when they are up, and OFF when they are down. The dip switch settings configure the card for the following parameters:

MMI port speed selection

This dip switch setting selects the appropriate baud rate for the terminal or modem (if any) that is connected to the MMI.

Line Supervisory Signaling protocol

As described in “Line-side T1 call operation” on page 34, the line-side T1 card is capable of supporting loop start or ground start call processing modes. Make the selection for this dip switch position based on what type of line signaling the CPE equipment supports.

Address of line-side T1 card to the MMI

The address of the line-side T1 card to the MMI is made up of two components:

- The address of the card within the shelf
- The address of the shelf in which the card resides

These two addresses are combined to create a unique address for the card. The MMI reads the address of the card within the shelf from the card firmware; however the address of the shelf must be set by this dip switch.

Figure 17
Line-side T1 card – T1 protocol dip switch locations

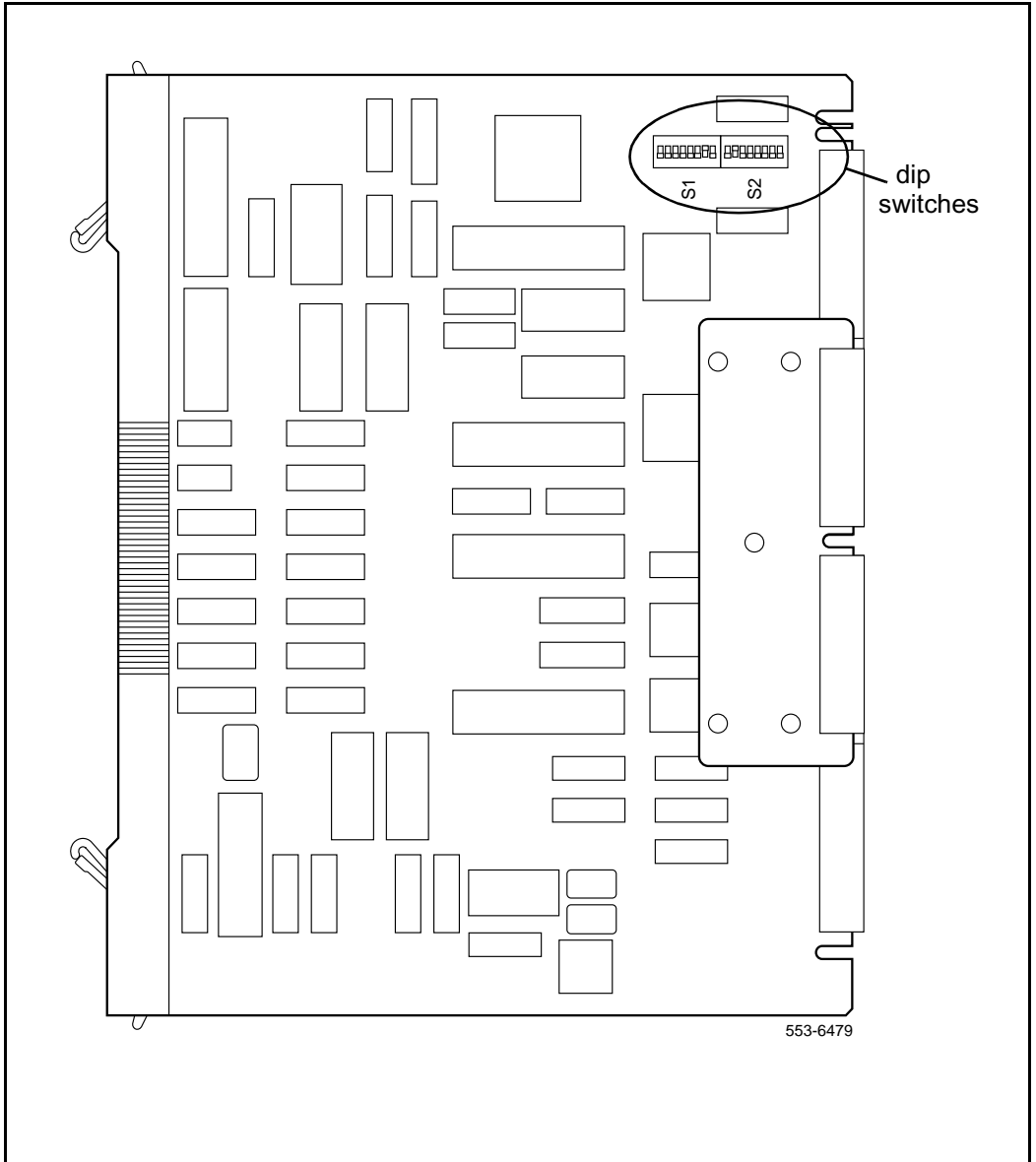

The shelf address dip switch can be from 0 – 15. 16 is the maximum number of line-side T1 IPE shelves (a maximum of 64 line-side T1 cards) capable of daisy chaining to a single MMI terminal. For ease, it is recommended that this address be set the same as the address of the peripheral controller identifier in LD 97 for type: XPE. However, this is not mandatory, and, since the dip switch is limited to 16, this will not always be possible.

T1 framing

The line-side T1 card is capable of interfacing with CPE or CSU equipment either in D4 or ESF framing mode. Make the selection for this dip switch position based on what type of framing the CPE or CSU equipment supports.

T1 Coding

The line-side T1 card is capable of interfacing with CPE or CSU equipment using either AMI or B8ZS coding. Make the selection for this dip switch position based on what type of coding the CPE or CSU equipment supports.

DSX-1 length

Estimate the distance between the line-side T1 card and the hardwired local CPE, or the Telco demarc RJ48, for the carrier facility connecting the line-side T1 and the remote CPE. Make the selection for this dip switch position based on this distance.

Line supervision on T1 failure

This setting determines in what state all 24 ports of the line-side T1 card appears to the Meridian 1 in case of T1 failure. Ports can appear to the Meridian 1 as either in the on-hook or off-hook states on T1 failure.

Note: All idle line-side T1 lines will go off-hook and seize a Digitone Receiver when the off-hook line processing is invoked on T1 failure. This may prevent DID trunks from receiving incoming calls until the line-side T1 lines time-out and release the DTRs.

Daisy-Chaining to MMI

If two or more line-side T1 cards are installed and the MMI is used, daisy-chain the cards together to use one MMI terminal or modem, See Figure 19 on page 97. Make the selection for this dip switch position based on how many line-side T1 cards will be installed.

MMI Master or Slave

This setting is used only if daisy-chaining the cards to the MMI terminal or modem. This setting determines whether this card is a master or a slave in the MMI daisy-chain. Select the master setting if this card is the card that is cabled directly into the MMI terminal or modem; select the slave setting if this card is cabled to another line-side T1 card in a daisy chain.

Tables 17 through 20 describe the proper dip switch settings for each type of T1 link. After the card has been installed, the MMI displays the DIP switch settings the command **Display Configuration** is used. See “Man-Machine T1 maintenance interface software” on page 100 for details on how to invoke this command.

Table 17
Line-side T1 card—T1 Switch 1 (S1) dip switch settings

Dip Switch Number	Characteristic	Selection
1	MMI port speed selection	On = 1200 baud Off = 2400 baud
2	T1 signaling	On = Ground start Off = Loop start
3–6	XPEC Address for the line-side T1 card	See Table 18 on page 86.
7	Not Used	Leave Off
8	Reserved for SL-100 use	Leave Off

Table 18
Line-side T1 card – XPEC address dip switch settings (Switch S1, positions 3 – 6)

XPEC Address	S1 Switch Position 3	S1 Switch Position 4	S1 Switch Position 5	S1 Switch Position 6
00	Off	Off	Off	Off
01	Off	Off	Off	On
02	Off	Off	On	Off
03	Off	Off	On	On
04	Off	On	Off	Off
05	Off	On	Off	On
06	Off	On	On	Off
07	Off	On	On	On
08	On	Off	Off	Off
09	On	Off	Off	On
10	On	Off	On	Off
11	On	Off	On	On
12	On	On	Off	Off
13	On	On	Off	On
14	On	On	On	Off
15	On	On	On	On

Table 19
Line-side T1 card – T1 Switch 2 (S2) dip switch settings

Dip Switch Number	Characteristic	Selection
1	T1 framing	On = D4 Off = ESF
2	T1 Coding	On = AMI Off = B8ZS
3–5	CPE or CSU distance	See Table 20
6	Line processing on T1 link failure	On = On-hook Off = Off-hook
7	Daisy-chaining to MMI	On = Yes Off = No
8	MMI Master or Slave	On = Master Off = Slave

Table 20
Line-side T1 card – CPE or CSU distance dip switch settings (Switch S2, positions 3 – 5)

Distance	S2 Switch Position 3	S2 Switch Position 4	S2 Switch Position 5
0–133	On	Off	Off
134–266	Off	On	On
267–399	Off	On	Off
400–533	Off	Off	On
534–655	Off	Off	Off

Installation

This section describes how to install and test the line-side T1 card. For more specific installation instructions for circuit cards in general, see *Circuit card installation and testing* (553-3001-211).

When installed, the line-side T1 card occupies two card slots. It can be installed into an NT8D37 Intelligent Peripheral Equipment (IPE) Module.

When installing the line-side T1 card into NT8D37 IPE module, determine the vintage level module. If the 25-pair I/O connectors are partially split between adjacent IPE card slots, the line-side T1 card works only in card slots where Unit 0 of the motherboard card slot appears on the first pair of the 25-pair I/O connector.

Certain vintage levels have dedicated 25-pair I/O connectors only for card slots 0, 4, 8, and 12. These vintage levels are cabled with only 16 pairs of wires from each card slot to the I/O panel. Some of the 25-pair I/O connectors are split between adjacent card slots. Other vintage levels cable each card slot to the I/O panel using a unique, 24-pair connector on the I/O panel. In these vintage levels, the line-side T1 card can be installed in any available pair of card slots. However, because of the lower number of wire pairs cabled to the I/O panel in the lower vintage level, only certain card slots are available to the line-side T1 card.

See Table 21 for the vintage level information for the NT8D37 IPE modules.

Table 21
Line-side T1 card – NT8D37 IPE Module vintage level port cabling

Vintage Level	Number of ports cabled to I/O panel
NT8D37AA	16 ports
NT8D37BA	24 ports
NT8D37DC	16 ports
NT8D37DE	16 ports
NT8D37EC	24 ports

Available and restricted card slots in the NT8D37 IPE Module

If the line-side T1 card is installed in an NT8D37 IPE Module, the available card slots depend on the vintage level module.

Vintage levels cabling 24 ports

For modules with vintage levels that cabled 24 ports to the I/O panel, the line-side T1 card can be installed in any pair of card slots 015.

Vintage levels cabling 16 ports

For modules with vintage levels that cabled 16 ports to the I/O panel, the line-side T1 card can be installed into the following card slot pairs:

Available:	Motherboard/Daughterboard
	0 and 1
	1 and 2
	4 and 5
	7 and 8
	8 and 9
	9 and 10
	12 and 13
	13 and 14

The line-side T1 card cannot be installed into the following card slot pairs:

Restricted:	Motherboard/Daughterboard
	2 and 3
	3 and 4
	6 and 7
	10 and 11
	11 and 12
	14 and 15

If the line-side T1 card must be installed into one of the restricted card slot pairs, rewire the IPE module card slot to the I/O panel by installing an additional NT8D81 cable from the line-side T1 card motherboard slot to the I/O panel. Re-arrange the three backplane connectors for the affected card

slots. This will permit the connection of the NT5D13AA Line-side T1 card carrier and maintenance external I/O cable at the IPE module I/O panel connector for card slots that are otherwise restricted.

Also, all line-side T1 card connections can be made at the main distribution frame instead of connecting the NT5D13 Line-side T1 card external I/O cable at the I/O panel. This eliminates these card slots restrictions.

Cabling the line-side T1 card

After setting the dip switches and installing the line-side T1 card into the selected card slots, the line-side T1 card is ready to be cabled to the CPE or CSU equipment. Connections can also be made to the MMI terminal or modem (optional), an external alarm (optional), and other line-side T1 cards for daisy-chain use of the MMI terminal (optional).

The line-side T1 card is cabled from its backplane connector through connections from the motherboard circuit card only (no cable connections are made from the daughterboard circuit card) to the input/output (I/O) panel on the rear of the IPE module. The connections from the line-side T1 card to the I/O panel are made with the NT8D81AA Tip and Ring cables provided with the IPE module.

Cabling from the I/O panel with the NT5D13AA Line-side T1 I/O cable

Usually, the I/O panel is connected to the T1 link and other external devices through the NT5D13AA Line-side T1 I/O cable. See Figure 18 on page 91. This cable consists of a 25-pair amphenol connector (P1) on one end which plugs into the I/O panel. The other end has 4 connectors:

- 1 a DB15 male connector (P2) which plugs into the T1 line
- 2 a DB9 male connector (P3) which plugs into an external alarm system
- 3 a second DB9 male connector (P5) which connects to an MMI terminal or modem
- 4 a DB9 female connector (P4) that connects to the next line-side T1 card's P4 connector for MMI daisy chaining

Figure 18
Line-side T1 card – connection using the NT5D13AA Line-side T1 Cable

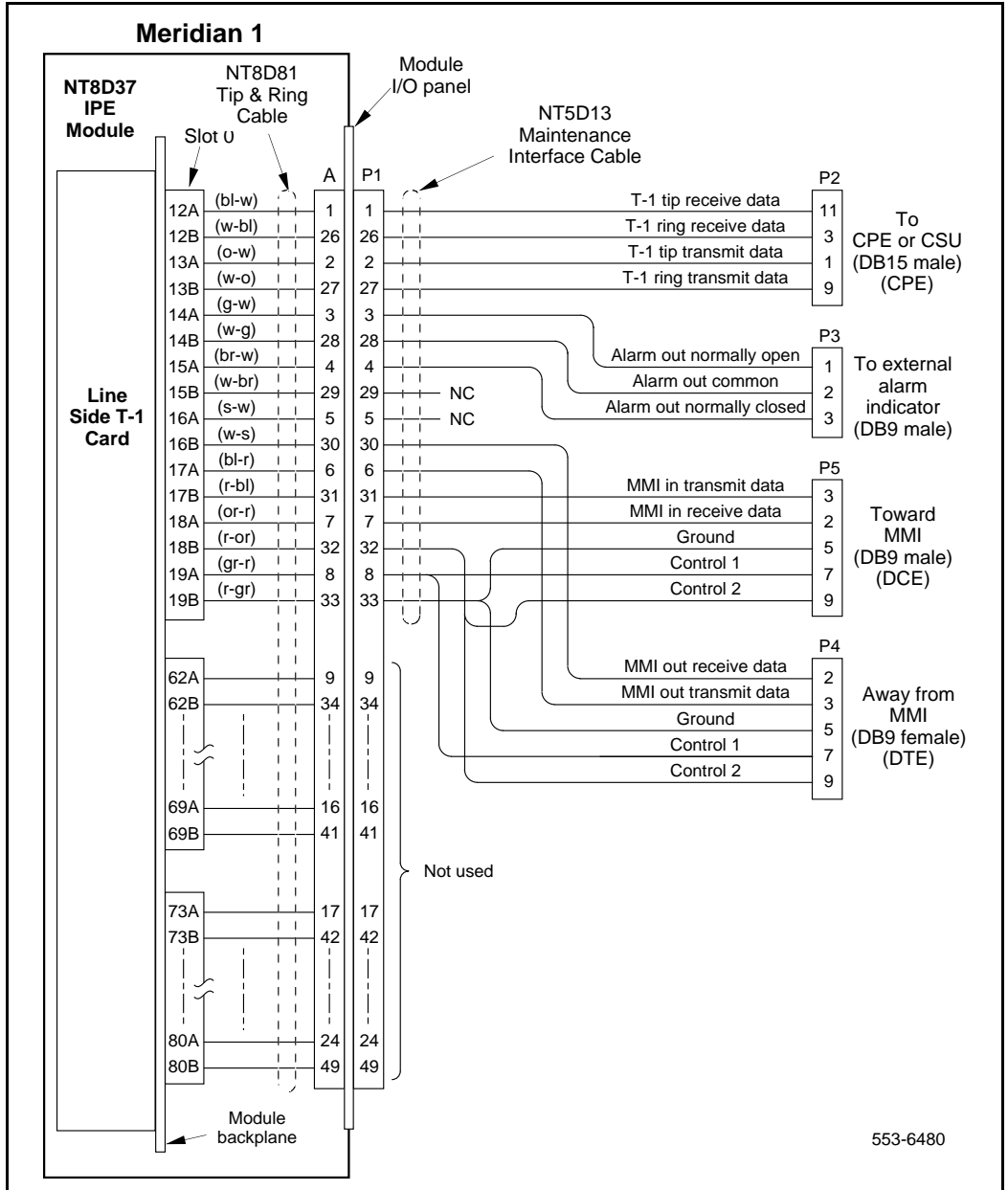

Cabling from the I/O panel at the Main Distribution Frame

All line-side T1 connections can be made at the main distribution frame (MDF) if it is preferred to not use the NT5D13AA Line-side T1 I/O cable at the I/O panel.

To make the connections at the MDF, follow this procedure:

- 1** Punch down the first eight pairs of a standard telco 25-pair female-connectorized cross-connect tail starting with the first tip and ring pair of the line-side T1 motherboard card slot on the cross-connect side of the MDF terminals.
- 2** Plug the NT5D13AA Line-side T1 I/O cable into this 25-pair cross-connect tail at the MDF, regardless of the card slot restrictions that exist from the vintage level of IPE or CE/PE module used. This connection can also be made at the MDF without using the NT5D13 Line-side T1 I/O cable, by cross-connecting according to the pinouts in Table 22.
- 3** Turn over the T1 transmit and receive pairs, where required for hardwiring the line-side T1 card to local CPE T1 terminal equipment.

The backplane connector is arranged as an 80-row by 2-column array of pins. Table 22 on page 93 shows the I/O pin designations for the backplane connector and the 25-pair Amphenol connector from the I/O panel. Although the connections from the I/O panel only use 14 of the available 50 pins, the remaining pins are reserved and cannot be used for other signaling transmissions.

The information in Table 22 is provided as a reference and diagnostic aid at the backplane, since the cabling arrangement can vary at the I/O panel. See *System Installation Procedures* (553-3001-210) for cable pinout information for the I/O panel.

Table 23 on page 94 shows the pin assignments when using the NT5D13AA Line-side T1 I/O cable.

Table 22
Line-side T1 card – backplane pinouts

Backplane Connector Pin	I/O Panel Connector Pin	Signal
12A	1	T1 Tip, Receive Data
12B	26	T1 Ring, Receive Data
13A	2	T1 Tip, Transmit Data
13B	27	T1 Ring, Transmit Data
14A	3	Alarm out, Normally open
14B	28	Alarm out, Common
15A	4	Alarm out, Normally closed
15B	29	No Connection
16A	5	No Connection
16B	30	Away from MMI terminal, Receive Data
17A	6	Away from MMI terminal, Transmit Data
17B	31	Towards MMI terminal, Transmit Data
18A	7	Towards MMI terminal, Receive Data
18B	32	Daisy-chain Control 2
19A	8	Daisy-chain Control 1
19B	33	Ground

Table 23
Line-side T1 card – NT5D13AA Connector pinouts

I/O Panel Connector Pin	Lead Designations	NT5D13AA Line-side T1 I/O Connector Pin	Line-side T1 cable connector to external equipment
1	T1 Tip Receive Data	11	DB15 male to T1 (P2) Line-side T1 card is CPE transmit to network and receive from network
26	T1 Ring Receive Data	3	
2	T1 Tip Transmit Data	1	
27	T1 Ring Transmit Data	9	
3	Alarm out common	1	DB9 male to external alarm (P3)
28	Alarm out (normally open)	2	
4	Alarm out (normally closed)	3	
7	Towards MMI terminal Receive Data	2	DB9 male towards MMI (P5) Wired as DCE Data is transmitted on pin 2 (RXD) and received on pin 3 (TXD)
31	Towards MMI terminal Transmit Data	3	
33	Ground	5	
8	Control 1	7	
32	Control 2	9	
33	Ground	5	DB9 female away from MMI (P4) Wired as DTE Data is transmitted on pin 2 (TXD) and received on pin 3 (RXD)
8	Control 1	7	
32	Control 2	9	
30	Away from MMI terminal Transmit Data	3	
6	Away from MMI terminal Receive Data	2	

T1 connections

T1 signaling for all 24 channels is transmitted over P2 connector pins 1, 3, 9, and 11 as shown in Table 23 on page 94. Plug the DB15 male connector labeled “P2” into the T1 link. T1 transmit and receive pairs must be turned over between the line-side T1 card and CPE equipment that is hardwired without carrier facilities. If the line-side T1 card is connected through T1 carrier facilities, the transmit and receive pairs must be wired straight through to the RJ48 at the Telco demarc, the CSU, or other T1 carrier equipment. The T1 CPE equipment at the far end will also have transmit and receive wired straight from the RJ48 demarc at the far end of the carrier facility.

External alarm connections

P3 connector pins 3, 4, and 28 can be plugged into any external alarm hardware. Plug the male DB9 connector labeled “P3” into the external alarm. These connections are optional, and the functionality of the line-side T1 card is not affected if they are not made.

The MMI (described in detail in “Man-Machine T1 maintenance interface software” on page 100) monitors the T1 link for specified performance criteria and reports on problems detected.

One of the ways it can report information is through this external alarm connection. If connected, the line-side T1 card’s microprocessor activates the external alarm hardware if it detects certain T1 link problems that it has classified as alarm levels 1 or 2. See “Man-Machine T1 maintenance interface software” on page 100 for a detailed description of alarm levels and configuration. If an alarm level 1 or 2 is detected by MMI, the line-side T1 card will close the contact that is normally open, and will open the contact that is normally closed. The MMI command **Clear Alarm** will return the alarm contacts to their normal state.

MMI connections

P5 connector pins 2, 3, 5, 7 and 9 are used to connect the line-side T1 card to the MMI terminal and daisy chain line-side T1 cards together for access to a shared MMI terminal. When logging into a line-side T1 card, “control 2” is asserted by that card, which informs all of the other cards not to talk on the bus, but rather to pass the data straight through. The pins labeled “control 1” are reserved for future use. As with the external alarm connections, MMI connections are optional. Up to 128 line-side T1 cards, located in up to 16 separate IPE shelves, can be linked to one MMI terminal using the daisy chaining approach.

If only *one* line-side T1 card is being installed, cable from the DB9 female connector labeled “P5” (towards MMI terminal) to one of the COM ports on the back of any TTY, a PC running a terminal emulation program, or a modem. For installations of only one card, no connection is made to the DB9 male connector labeled “P4” (away from MMI terminal).

If *two or more* line-side T1 cards are being installed into the Meridian 1 system, the MMI port connections can be daisy-chained together so that only one MMI terminal is required for up to 128 line-side T1 cards. See Figure 19 on page 97. Cards can be located in up to 16 separate IPE shelves. Any card slot in the IPE shelf can be connected to any other card slot; the card slots connected together do not need to be consecutive.

Follow this procedure for connecting two or more line-side T1 cards to the MMI terminal:

- 1 Cable the DB9 male connector labeled “P5” (towards MMI terminal) to one of the COM ports on the back of any TTY, a PC running a terminal emulation program, or a modem.
- 2 Make the connection from the first card to the second card by plugging the DB9 female connector labeled “P4” (away from MMI terminal) from the *first* card into the DB9 male connector of the second card labeled “P5” (towards MMI terminal).
- 3 Repeat Step 2 for the remaining cards.
- 4 When the last card in the daisy chain is reached, make no connection to the DB9 male connector labeled “P4” (away from MMI terminal).

- 5 If two line-side T1 cards are located too far apart to connect the "P4" and "P5" connectors together, connect them together with an off-the-shelf DB-9 female to DB-9 male straight-through extension cable, available at any PC supply store.

Figure 19
Line-side T1 card – connecting two or more cards to the MMI

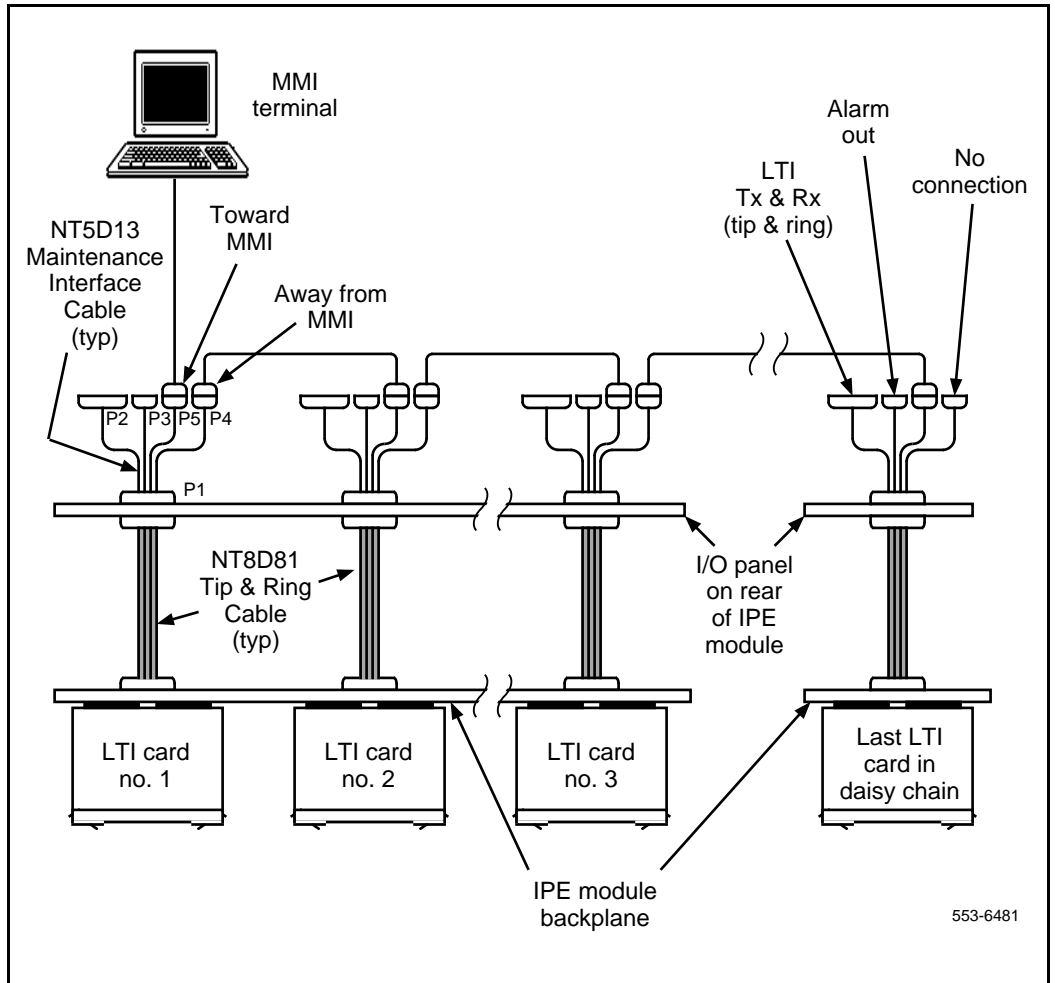

553-6481

Terminal configuration

For the MMI terminal to be able to communicate to the line-side T1 card, the interface characteristics must be set to the following:

- Speed – 1200 or 2400 bps, depending on the setting of switch position 1 of Switch 1
- Character width – 8 bits
- Parity bit – none
- Stop bits – one
- Software handshake (XON/XOFF) – off

Software configuration

Although much of the architecture and many of the features of the line-side T1 card differ from the analog line card, the line-side T1 card has been designed to emulate an analog line card to the Meridian 1 software. Because of this, the line-side T1 card software configuration is performed the same as two adjacent analog line cards.

All 24 T1 channels carried by the line-side T1 card are individually configured using the Analog (500/2500-type) Telephone Administration program LD 10. Use Table 24 on page 99 to determine the correct unit number and the NTP *Administration* (553-3001-311) for LD 10 service change instructions.

The line-side T1 card circuitry routes 16 units (0-15) on the motherboard and eight (0-7) units on the daughterboard to 24 T1 channels. The motherboard circuit card is located in the left card slot, and the daughterboard circuit card is located in right card slot. For example, if the line-side T1 card is installed into card slots 0 and 1, the motherboard would reside in card slot 0 and the daughterboard would reside in card slot 1. In order to configure the terminal equipment through the switch software, the T1 channel number must be cross-referenced to the corresponding card unit number. This mapping is shown in Table 24.

Table 24
DX-30 to T1 time slot mapping

TN		T1 Channel Number
Motherboard	0	1
Motherboard	1	2
Motherboard	2	3
Motherboard	3	4
Motherboard	4	5
Motherboard	5	6
Motherboard	6	7
Motherboard	7	8
Motherboard	8	9
Motherboard	9	10
Motherboard	10	11
Motherboard	11	12
Motherboard	12	13
Motherboard	13	14
Motherboard	14	15
Motherboard	15	16
Daughterboard	0	17
Daughterboard	1	18
Daughterboard	2	19
Daughterboard	3	20
Daughterboard	4	21
Daughterboard	5	22
Daughterboard	6	23
Daughterboard	7	24

Disconnect supervision

The line-side T1 card supports far-end disconnect supervision by opening the tip side toward the terminal equipment upon the Meridian 1 system's detecting a disconnect signal from the far-end on an established call. The Supervised Analog Line feature (SAL) must be configured in LD 10 for each line-side T1 port. At the prompt FTR, respond

OSP <CR>

and against FTR respond

ISP <CR>

The line-side T1 card treats OSP and ISP for both originating and terminating calls as hook flash disconnect supervision, also known as cut-off disconnect. Originating calls are outgoing from the terminal equipment. Terminating calls are incoming to the terminal equipment. The line-side T1 card does not support battery reversal answer and disconnect supervision on originating calls.

After the software is configured, power up the card and verify the self test results. The **STATUS LED** on the faceplate indicates whether or not the line-side T1 card has passed its self test, and is functional. When the card is installed, this LED remains lit for two to five seconds as the self-test runs. If the self-test completes successfully, the LED flashes three times and remains lit. When the card is configured and enabled in software, the LED goes out. The LED goes out if either the motherboard or daughterboard is enabled by the software. If the LED flashes continuously or remains weakly lit, replace the card.

Man-Machine T1 maintenance interface software

Description

The Man-Machine Interface (MMI) supplies a maintenance interface to a terminal that provides T1 link diagnostics and historical information. See “Installation and Configuration” on page 81 for instructions on how to install the cabling and configure the terminal for the MMI.

This section describes the features of MMI and explains how to set-up, configure and use the MMI firmware.

The MMI provides the following maintenance features:

- default and reconfigurable alarm parameters
- notification of T1 link problems by activating alarms
- Reports on current and historical T1 link performance
- T1 tests for T1 verification and fault isolation to line-side T1 card, T1 link, or CPE equipment

Alarms

MMI activates alarms for the following T1 link conditions:

- excessive bit error rate
- frame slip errors
- out of frame condition
- loss of signal condition
- blue alarm condition

The alarms are activated in response to pre-set thresholds and error durations. Descriptions of each of these T1 link alarm conditions, instructions on how to set alarm parameters, and access alarm reporting can be found in “Alarm operation and reporting” on page 111.

Two levels of alarm severity exist for bit errors and frame slip errors. For these conditions, two different threshold and duration settings are established.

When the first level of severity is reached (alarm level 1), the MMI will do the following:

- activate the external alarm hardware
- light the appropriate LED on the faceplate (either RED ALARM or YELLOW ALARM)
- display an alarm message on the MMI terminal
- create entry in the alarm log

When the second level of severity is reached (alarm level 2), the MMI will perform all of the same functions as alarm level 1, and in addition, force the line-side T1 card to enter trunk processing mode. In this mode, the terminal equipment will be sent either “on-hook” or “off-hook” signals for all 24 ports to the Meridian 1, depending on how the dip switch for trunk processing was set (dip switch #2, position #6).

If the MMI detects T1 link failures for any of the remainder of the conditions monitored (out of frame condition, loss of signal condition, and blue alarm condition), the line-side T1 card automatically performs all alarm level 2 functions. The MMI also sends a yellow alarm to the distant end CPE or CSU.

Alarms can be set up to self-clear or not self-clear when the alarm condition is no longer detected.

All alarms activated produce a record in an alarm log. The alarm log maintains records for the most recent 100 alarms and can be displayed, printed and cleared. The alarm log displays or prints the alarms listing the most recent first in descending chronological order. The alarms are stamped with the date and time they occurred.

T1 Performance Counters and Reports

The MMI maintains performance error counters for the following T1 conditions:

- errored seconds
- bursty seconds
- unavailable seconds
- framer slip seconds
- loss of frame seconds

It retains the T1 performance statistics for the current hour, and for each hour for the previous 24 hours. Descriptions of each of these performance error counters, and instructions on how to report on them and clear them can be found in “Performance counters and reporting” on page 114.

T1 Verification and Fault Isolation Testing

The MMI performs various tests to verify that the T1 is working adequately, or help to isolate a problem to the line-side T1 card, the T1 link, or the CPE equipment. Descriptions of all of these tests and instructions on how to run them can be found in “Testing” on page 116.

Login and Password

The MMI can be accessed through a TTY, a PC running a terminal emulation program, or a modem. After installing the MMI terminal and card cables, the MMI firmware can be accessed.

For single card installations, it is accessed by entering

L<CR>

to login.

For multiple card installations connected in a daisy-chain, it is accessed by entering

L <address>

where the four-digit address is the two-digit address of the IPE shelf as set by dip switch positions (dip switch #1, positions 3-6) on the card (as opposed to the address set in the Meridian 1 software), plus the two-digit address of the card slot that the motherboard occupies. For example, to login to a card located in shelf 13, card slot 4, type:

L 13 4 <CR>

A space is inserted between the login command (L), the shelf address, and the card slot address

The MMI then prompts for a password. The password is “**LTILINK**”, and it must be typed all in capital letters.

After logging in, the prompt will then look like this:

- **LTI:::>** for single-card installations
- **LTI:ss cc>** for multi-card installations, where ss represents the two-digit address, and cc represents the two-digit card slot address

Basic commands

MMI commands can now be executed. There are seven basic commands that can be combined together to form a total of 19 command sets. They are:

- Alarm
- Clear
- Display
- Set
- Test
- Help
- Quit

If ?<CR> is typed, the MMI will list the above commands along with an explanation of their usage. A screen similar to the following will appear. The help screen can also appear by typing H<CR>, or HELP<CR>.

```
ALARM  USAGE: Alarm [Enable | Disable]
CLEAR  USAGE: Clear [Alarm] | [Error counter] [Log]
DISPLAY USAGE: Display [Alarm | Status | Perform | History] [Pause]
HELP   USAGE: Help | ?
SET    USAGE: Set [Time | Date | Alarm | Clearing | Name | Memory]
TEST   USAGE: Test [Carrier All]
QUIT   USAGE: Quit
```

Notation Used:

CAPS - Required Letters [] - Optional | - Either/Or

Each of these commands can be executed by typing the first letter of the command or by typing the entire command. Command sets are entered by typing the first letter of the first command, a space, and the first letter of the second command or by typing the entire command. Table 25 on page 105 shows all the possible command sets, listed in alphabetical order. These commands are described by subject later in this section.

Table 25
MMI commands and command sets (Part 1 of 2)

Command	Description
A D	Alarm Disable Disables all alarms
A E	Alarm Enable Enables all alarms
C A	Clear Alarm Clears all alarms, terminates line processing, and resets the T1 bit error rate and frame slip counters
C A L	Clear Alarm Log Clears the alarm log
C E	Clear Error Clears the error counter for the T1
D A [P]	Display Alarms [Pause] Displays the alarm log – a list of the most recent 100 alarms along with time and date stamps
D C	Display Configuration Displays the configuration settings for the cards including: <ul style="list-style-type: none"> • the serial number of the card • MMI firmware version • date and time • alarm enable/disable setting • self-clearing enable/disable setting • settings entered in Set Configuration • dip switch settings
D H [P]	Display History [Pause] Displays performance counters for the past 24 hours.
D P	Display Performance Displays performance counters for the current hour.
D S [P]	Display Status [Pause] Displays carrier status, including whether the card is in the alarm state, and what alarm level is currently active.

Table 25
MMI commands and command sets (Part 2 of 2)

Command	Description
H or ?	Help Displays the help screen
L	Login Logs into the MMI terminal when the system has one line-side T1 card
Q	Quit Logs the terminal user out. If multiple line-side T1 cards share a single terminal, logout after using the MMI. Because of the shared daisy-chained link, if a line-side T1 card is logged in, it occupies the bus and no other line-side T1 cards are able to notify the MMI of alarms.
S A	Set Alarm parameters Alarm parameters include the allowable bit errors per second threshold and alarm duration
S C	Set Clearing Sets the alarm self-clearing function to either <i>enable</i> or <i>disable</i>
S D	Set Date Sets date or verifies current date
S T	Set time Sets time or verifies current time
T x	Test Initiates the T1 carrier test function. To terminate a test in process, enter the STOP TEST (S) command at any time.

Configuring parameters

The MMI has been designed with default settings so that no configuration is necessary. However, it can be configured to suit a specific environment.

Set Time

Before configuring the MMI, login to the system and enter the current time. Do this by typing in the Set Time (S T) command set. The MMI will then display the time it has registered. Enter a new time or press “Enter” to leave it unchanged. The time is entered in the “hh:mm:ss” military time format.

Set Date

The current date must be set. Do this by typing in the Set Date (S D) command set. MMI will then display the date it has registered. Enter a new date or press “Enter” to leave it unchanged. The date is entered in the “mm/dd/yy” format.

Alarm parameters

The Set Alarm (S A) command set establishes the parameters by which an alarm is activated, and its duration. There are three alarm activation levels:

- **Alarm Level 0 (AL0)** consists of activity with an error threshold below the AL1 setting. This is a satisfactory condition and no alarm is activated.
- **Alarm Level 1 (AL1)** consists of activity with an error threshold above the AL1 setting but below AL2 setting. This is a minor unsatisfactory condition. In this situation, the external alarm hardware will be activated by closing the normally open contact, the RED ALARM LED on the faceplate will light, and an alarm message will be created in the alarm log and the MMI terminal.
- **Alarm Level 2 (AL2)** consists of activity with an error threshold above the AL2 setting. This is an unsatisfactory condition. In this situation, the external alarm hardware will be activated by closing the normally open contact, the RED ALARM LED on the faceplate will light, an alarm message will be created in the alarm log and the MMI terminal, the line-side T1 card will enter line processing mode, and a yellow alarm message will be sent to the CPE/CSU. Line processing will send the Meridian 1 either all “on-hook” or all “off-hook” signals, depending on the dip switch setting of the card.

When the Set Alarm command is used, a prompt appears to set the threshold level and duration period for alarm levels 1 and 2.

The threshold value indicates the number of bit errors detected per second that is necessary to activate the alarm. The T1 link processes at a rate of approximately 1.5 mb/s. The threshold value can be set between 3 and 9 and can be different for each alarm level. Any other value entered will cause the software to display a “Parameter Invalid” message. The threshold number entered represents the respective power of 10 as shown in Table 26.

Note: The error rate threshold for a level 2 alarm must be greater (a smaller power of 10) than for a level 1 alarm.

Table 26
T1 bit error rate threshold settings

Alarm Threshold bit errors per second in Power of 10	Threshold to set alarm	Allowable Duration Periods
10^{-3}	1,500/second	1–21 seconds
10^{-4}	150/second	1–218 seconds
10^{-5}	15/second	1–2148 seconds
10^{-6}	1.5/second	1–3600 seconds
10^{-7}	1.5/10 seconds	10–3600 seconds
10^{-8}	1.5/100 seconds	100–3600 seconds
10^{-9}	1.5/1000 seconds	1000–3600 seconds

The duration value is set in seconds and can be set from 1 to 3600 seconds (1 hour). This duration value indicates how long the alarm will last. Low bit error rates (10^{-7} through 10^{-9}) are restricted to longer durations since it takes more than one second to detect an alarm condition above 10^{-6} . Higher bit error rates are restricted to shorter durations because the MMI error counter fills at 65,000 errors.

The alarm indications (LEDs and external alarm contacts) clear automatically after the duration period has expired, if the Set Clearing (S C) “Enable Self Clearing” option has been set. Otherwise, the alarm will continue until the command set Clear Alarm (C A) has been entered.

When an alarm is cleared, the following activity caused by the alarm will be cleared:

- the external alarm hardware will be deactivated (the contact normally open will be reopened)
- the LED light will go out
- an entry will be made in the alarm log of the date and time the alarm was cleared
- carrier fail line supervision will cease (for alarm level 2 only)

If self-clearing alarm indications have been disabled, carrier fail line supervision will terminate when the alarm condition has ceased, but the alarm contact and faceplate LED will remain active until the alarm is cleared.

Note: A heavy bit error rate can cause 150 bit errors to occur in less than 100 seconds. This will cause the alarm to be activated sooner.

An alarm will not be automatically cleared until the system no longer detects the respective bit error threshold during the corresponding duration period.

For example, if an AL1 threshold of 6 (representing 10^{-6}) and a duration period of 100 seconds is specified, an alarm will be activated if more than 150 bit errors occur in any 100 second period ($1.5 \text{ seconds} \times 100 \text{ seconds} = 150/100 \text{ seconds}$). As soon as the alarm is activated, the bit counter is reset to 0. If the next 100 seconds pass, and less than 150 bit errors are detected, then the alarm will clear after the duration period. However, if more than 150 bit errors are detected in the next 100 seconds, the alarm continues for the designated duration period. The alarm will finally clear when the alarm condition is no longer detected for the designated duration period either by self-clearing (if this function is enabled), or when the Clear Alarm (C A) command set is entered.

In addition to bit errors, the Set Alarm function sets parameters for detecting frame slip errors, by establishing a threshold necessary to activate an alarm. If the threshold value is exceeded, a level 2 alarm will be activated. The frame slip threshold can be specified from 1 to 255 frame slips per time period. The duration time period can be specified from 1 to 24 hours.

When entering the Set Alarm command set, the MMI will scroll through the previously described series of alarm options. These options are displayed along with their current value. Enter a new value or press Enter to retain the current value. Table 27 outlines the options available in the Set Alarm function.

Table 27
Set alarm options

Option	Description
AL1 Threshold	Sets the allowable bit errors per second (from 3 to 9) before alarm level 1 is activated. Factory default is 10^{-6} .
AL1 Duration	Sets the duration in seconds (from 1 to 3,600 seconds) that alarm level 1 is activated. Factory default is 10 seconds.
AL2 Threshold	Sets the allowable bit errors per second (from 3 to 9) before alarm level 2 is activated. Factory default is 10^{-5} .
AL2 Duration	Sets the duration in seconds (from 1 to 3,600 seconds) that alarm level 2 is activated. Factory default is 10 seconds
Frame Slip Threshold	Sets the allowable frame slips per time period (from 1 to 255) before alarm level 2 is activated. Factory default is 5.
Frame Slip Duration	Sets the duration in hours (from 1 to 24) that the frame slips are counted. After this time period, the counter is reset to 0. Factory default is 2 hours.

Note: If the duration period is set too long, the line-side T1 card will be slow to return to service automatically even when the carrier is no longer experiencing any errors. The Clear Alarm command will have to be entered manually to restore service promptly. To avoid this, the duration period should normally be set to 10 seconds.

Set Clearing

Use the Set Clearing (S C) command set to enable or disable alarm self-clearing. Answer **Y** or **N** to the question: “Enable Self Clearing? (YES or NO)”. If “Enable Self-Clearing” is chosen (the factory default condition), the system will automatically clear alarms after the alarm condition is no longer detected for the corresponding duration period.

The “Disable Self-Clearing” option causes the system to continue the alarm condition until the Clear Alarm (C A) command set is entered. Line processing and the yellow alarm indication to the CPE is terminated as soon as the alarm condition clears, even if “Disable Self-Clearing” is set.

Display Configuration

The Display Configuration (D C) command set displays the various configuration settings established for the line-side T1 card. Entering the Display Configuration (D C) command set causes a screen similar to the following to appear:

```
LTI S/N 1103 Software Version 1.01  3/03/95 1:50
Alarms Enabled: YES    Self Clearing Enabled: YES
Alarm Level 1 threshold value: E-7    Threshold duration (in seconds): 10
Alarm Level 2 threshold value: E-5    Threshold duration (in seconds): 1
Frame slips alarm level threshold: 5   Threshold duration (in hours): 2
Current dip switch S1 settings (S1..S8) On Off Off On Off Off Off On
Current dip switch S2 settings (S1..S8) On Off On Off Off Off On Off
```

Alarm operation and reporting

The MMI monitors the T1 link according to the parameters established through the Set Alarm command set for the following conditions:

- Excessive bit error rate
- Frame slip errors
- Out of frame condition
- Loss of signal condition
- Blue alarm (AIS) condition

Descriptions of the excessive bit error rate and frame slip errors conditions can be found in “Configuring parameters” on page 107. Bit errors may activate either a level 1 or level 2 alarm. The remaining conditions, when detected, will always cause the system to activate a level 2 alarm.

An out of frame condition will be declared if two out of four frame bits are in error. If this condition occurs, the hardware will immediately attempt to reframe. During the reframe time, the T1 link will be declared out of frame, and silence will be sent on all receive timeslots.

A loss of signal condition is declared if a full frame (192 bits) of consecutive zeros has been detected at the receive inputs. If this condition occurs, the T1 link will automatically attempt to resynchronize with the distant end. If this condition lasts for more than two seconds, a level 2 alarm will be declared, and silence will be sent on all receive timeslots. The alarm will be cleared if, after two seconds, neither a loss of signal, out of frame condition, nor blue alarm condition occurs.

If a repeating device loses signal, it immediately begins sending an unframed all 1's signal to the far-end to indicate an alarm condition. This condition is called a blue alarm, or an Alarm Indication Signal (AIS). If an AIS is detected for more than two seconds, a level 2 alarm will be declared, and silence will be sent on all receive timeslots. The alarm will be cleared if, after two seconds, neither a loss of signal, out of frame condition, nor blue alarm condition occurs.

Alarm Disable

The Alarm Disable (A D) command disables the external alarm contacts. When this command is typed, the MMI will display the message "Alarms Disabled" and the MAINT LED will light. In this mode, no yellow alarms are sent and the line-side T1 card will not enter line processing mode. Alarm messages will still be sent to the MMI terminal and the LED light will continue to indicate alarm conditions.

Alarm Enable

The Alarm Enable (A E) command set does the opposite of the Alarm Disable command set. It enables the external alarm contacts. When this command set is typed in, the MMI will display the message "Alarms Enabled." In this mode, yellow alarms can be sent and the line-side T1 card can enter line processing mode.

Clear Alarm

The Clear Alarm (C A) command set will clear all activity initiated by an alarm: the external alarm hardware will be deactivated (the contact normally open will be reopened), the LED light will go out, an entry will be made in the alarm log of the date and time the alarm was cleared, and line processing will cease (for alarm level 2 only). When this command set is typed in, the MMI will display the message "Alarm acknowledged." If the alarm condition still exists, the alarm will be declared again.

Display Alarms

A detailed report of the most recent 100 alarms with time and date stamps can be displayed by entering the Display Alarms (D A) command set into the MMI. Entering the Display Alarms (D A) command set will cause a screen similar to the following to appear:

Alarm Log

3/03/95 1:48 Yellow alarm on T1 carrier

3/03/95 1:50 Initialized Memory

3/03/95 2:33 T1 carrier level 1 alarm

3/03/95 3:47 T1 carrier level 2 alarm

3/03/95 4:43 T1 carrier performance within thresholds

3/03/95 15:01 Log Cleared

The Pause command can be used to display a full screen at a time by entering D A P.

Clear Alarm Log

Clear all entries in the alarm log by typing in the Clear Alarm Log (C A L) command set.

Display Status

The Display Status (D S) command set displays the current alarm condition of the T1 link as well as the on-hook or off-hook status of each of the 24 ports of the line-side T1 card. Entering the Display Status (D S) command set will cause a screen similar to the following to appear:

```
LTI S/N Software Version 1.01 3/03/95 1:50
In alarm state: NO
T1 link at alarm level 0
Port 0 off hook, Port 1 on hook, Port 2 on hook, Port 3 on hook,
Port 4 on hook, Port 5 on hook, Port 6 off hook, Port 7 off hook,
Port 8 off hook, Port 9 on hook, Port 10 on hook, Port 11 on hook,
Port 12 off hook, Port 13 on hook, Port 14 on hook, Port 15 on hook,
Port 16 on hook, Port 17 on hook, Port 18 off hook, Port 19 off hook,
Port 20 off hook, Port 21 on hook, Port 22 on hook, Port 23 on hook
```

Performance counters and reporting

The MMI monitors the performance of the T1 link according to several performance criteria including errored, bursty, unavailable, loss of frame and frame slip seconds. It registers the performance of these criteria by reading their status every second and counting their results. These counts are accumulated for an hour, and then they are reset to 0. Previous hour count results are maintained for each hour for the previous 24 hours.

Performance counts are maintained for the following:

- Errored seconds – one or more CRC-6 errors, or one or more out of frame errors in a second
- Bursty seconds – more than one and less than 320 CRC-6 errors in a second
- Unavailable seconds – unavailable state starts with 10 consecutive severely errored seconds and ends with 10 consecutive severely errored seconds (excluding the final 10 non-severely errored seconds). Severely errored seconds are defined as more than 320 CRC-6 errors, or one or more out of frames in a second.

- Loss of frame seconds – loss of frame or loss of signal for three consecutive seconds
- Framers slip seconds – one ore more frame slips in a second

The MMI also maintains an overall error counter that is a sum of all the errors counted for the five performance criteria listed above. The error counter can only be cleared by entering the “Clear Error” command. It will stop counting at 65,000. The error counter provides an easy method to determine if an alarm condition has been corrected. Simply clear the error counter, wait a few minutes, and display performance to see if any errors have occurred since the counter was cleared.

Display the reports on these performance counters by entering the Display Performance (D P) or the Display History (D H) command sets into the MMI.

Display Performance

Enter the Display Performance (D P) command set to display performance counters for the past hour. A screen similar to the following will appear:

```

LTI T1 Interface Performance Log
3/03/95 1:37

Data for the past 37 Minutes
Errored      Bursty      Unavailable  Loss Frame  Frame Slip  Error
Seconds      Seconds     Seconds      Seconds     Seconds     Counter
2263         0           2263         2263        352         321

```

Each column, except the error counter, indicates the number of errors in the current hour and is reset to zero every hour on the hour. When these counters are reset to zero, the performance counter values are put into the history log. The error counter indicates the number of errors that occurred since the error counter was cleared.

Display History

Enter the Display History (D H) command set to display performance counters for each hour for the past 24 hours. A screen similar to the following will appear:

```

LTI T1 Interface History Performance Log
      3/03/95 1:35
Hour   Errored   Bursty   Unavailable   Loss Frame   Frame Slip   Error
Ending Seconds  Seconds  Seconds      Seconds     Seconds     Seconds     Counter
20:00  139         0        129          139         23          162
19:00   0          0         0            0           0           0
18:00   0          0         0            0           0           0
17:00   0          0         0            0           0           0
16:00   0          0         0            0           0           0
    
```

Use the pause command to display a full screen at a time by entering D H P.

Clear Error

Reset the error counter to zero by entering the Clear Error (C E) command set. The error counter provides a convenient way to determine if the T1 link is performing without errors since it can be cleared and examined at any time.

Testing

The Test Carrier (T C) command set enables tests to be run on the line-side T1 card, the T1 link, or the CPE device. These three tests provide the capability to isolate faulty conditions in any one of these three sources. See Table 28 on page 117 for additional information on these three test types.

After entering the T C command set, select which test to start. The prompt appears, similar to the following:

```

Test 1: Local Loopback Test
Test 2: External Loopback Test
Test 3: Network Loopback Test
(1,2,3 or S to cancel):
    
```

Tests can be performed once (for 1 through 98 minutes), or continuously (selected by entering 99 minutes) until a “Stop Test” command is entered. Tests continue for the duration specified even if a failure occurs, and terminate at the end of the time period or when a “Stop Test” command is issued. Only a “Stop Test” command will stop a test with a duration selection of 99. After entering the test number selection, a prompt similar to the following will appear:

```

Enter Duration of Test (1-98 Mins, 0 = Once, 99 =
Forever)
Verify DS-30A Links are disabled.
Hit Q to quit or any Key to Continue

```

Before a test is run, verify that DS-30A links are disabled since the tests will interfere with calls currently in process.

During a test, if an invalid word is received, a failure peg counter is incremented. The peg counter saturates at 65,000 counts. At the end of the test, the Test Results message will indicate how many failures, if any, occurred during the test.

Table 28 shows which test to run for the associated equipment.

Table 28
MMI Tests

Test Number	Equipment Tested	Test Description
1	line-side T1 card	Local loopback
2	T1 link, line-side T1 card and T1 network	External loopback
3	CPE device and T1 network	Network loopback

Test 1, local loopback, loops the T1 link signaling toward itself at the backplane connector, and test data is generated and received on all timeslots. If this test fails, it indicates that the line-side T1 card is defective. Figure 20 on page 118 demonstrates how the signaling is looped back toward itself.

Figure 20
MMI Local loopback test

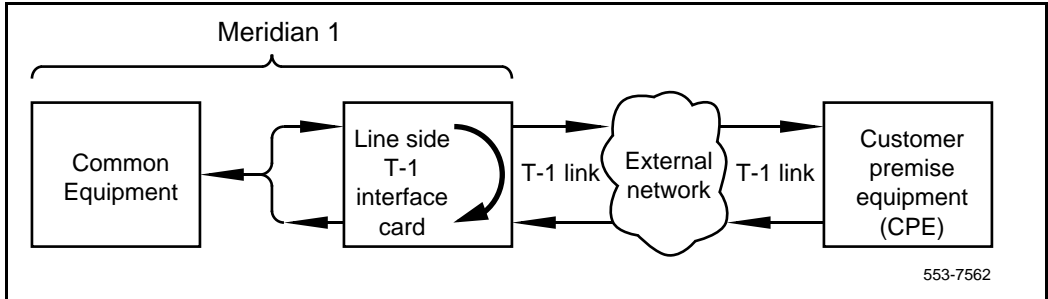

Test 2, external loopback, assumes an external loopback is applied to the T1 link. Test data is generated and received by the line-side T1 card on all timeslots. If test 1 passes but test 2 fails, it indicates that the T1 link is defective between the line-side T1 card and the external loopback location. If test 1 was not run and test 2 fails, the T1 link or the line-side T1 card could be defective. To isolate the failure to the T1 link, tests 1 and 2 must be run in tandem. Figure 21 demonstrates how an external loopback is applied to the T1 link.

Figure 21
MMI External loopback test

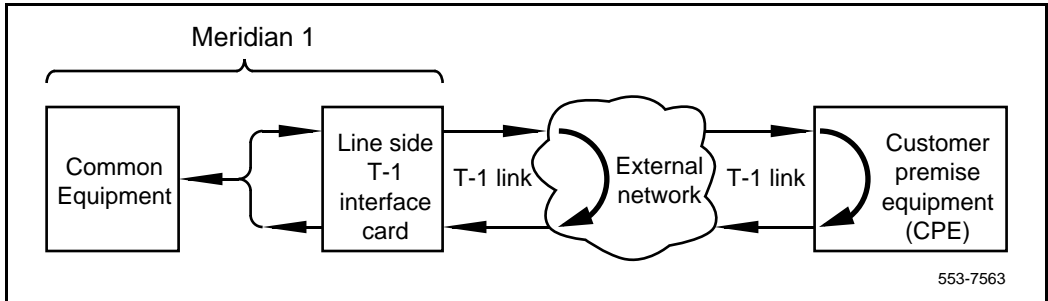

Test 3, network loopback, loops the received T1 data back toward the CPE equipment. No test data is generated or received by the line-side T1 card. If test 2 passes but test 3 fails, it indicates that the CPE device is defective. If test 2 was not run and test 3 fails, the T1 link or the CPE device could be defective. To isolate the failure to the CPE device, tests 2 and 3 must be run in tandem. Figure 22 demonstrates how the signaling is looped back toward the CPE equipment.

Figure 22
MMI Network loopback test

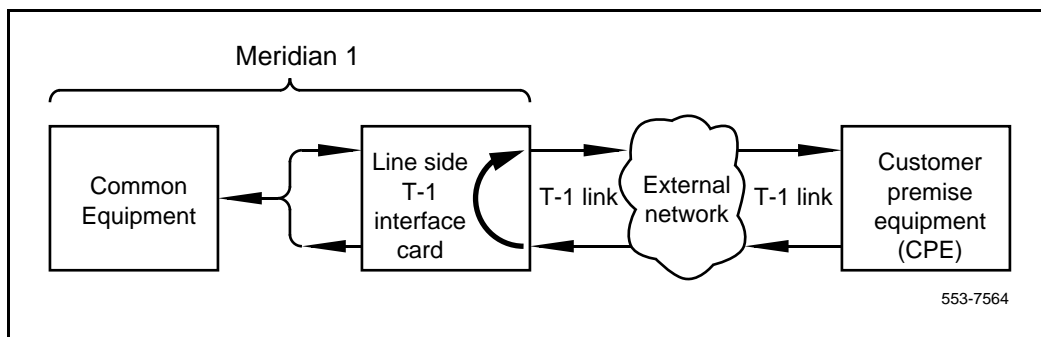

Applications

The line-side T1 interface is an Intelligent Peripheral Equipment (IPE) line card that provides cost-effective connection between T1-compatible peripheral equipment and a Meridian 1 system or off-premise extensions over long distances.

Some examples of applications where a line-side T1 card can be interfaced to a T1 link are:

- T1 compatible Voice Response Unit (VRU) equipment
- T1 compatible turret systems
- T1 compatible wireless systems
- Remote analog (500/2500-type) telephones through T1 to a channel bank
- Remote Norstar sites behind Meridian 1 over T1

The line-side T1 card is appropriate for any application where both T1 connectivity and “line-side” functionality is required. This includes connections to T1-compatible voice response units, voice messaging and trading turret (used in stock market applications) systems. See Figure 23.

Figure 23
Line-side T1 interface connection to peripheral equipment

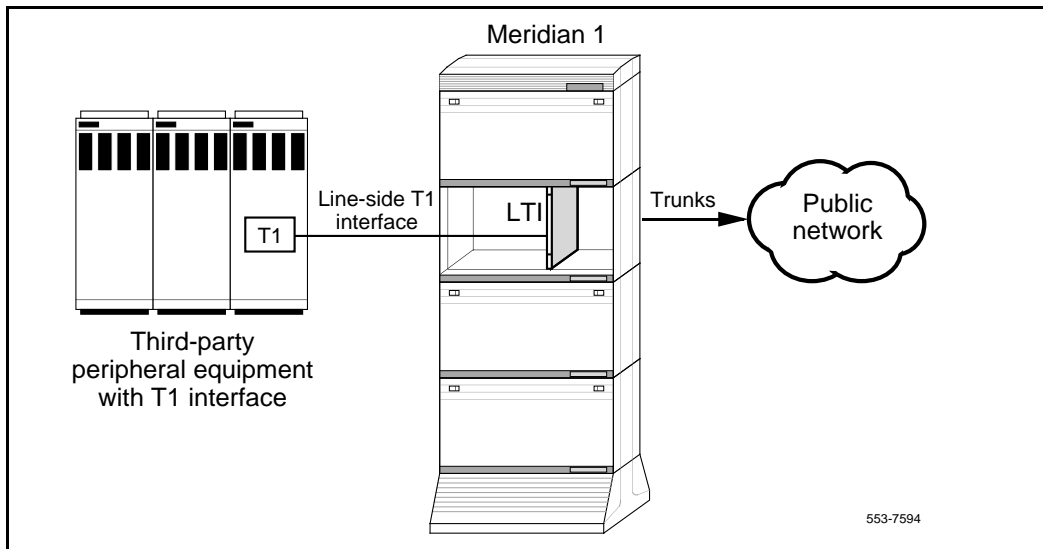

For example, the line-side T1 card can be used to connect the Meridian 1 to a T1-compatible VRU. An example of this type of equipment is Nortel Networks Open IVR system. In this way, the Meridian 1 can send a call to the VRU. Because the line-side T1 card supports analog (500/2500-type) telephones, the VRU is able to send the call back to the Meridian 1 for further handling.

The line-side T1 card can also be used to provide off-premise extensions to remote locations (up to 500 miles from the Meridian 1 system). In this application, the analog telephone functionality is extended over T1 facilities, providing a telephone at a remote site with access to analog (500/2500-type) telephone lines. See Figure 24 on page 121. An audible message-waiting indicator can be provided as well.

Figure 24
Line-side T1 interface in off-premise application

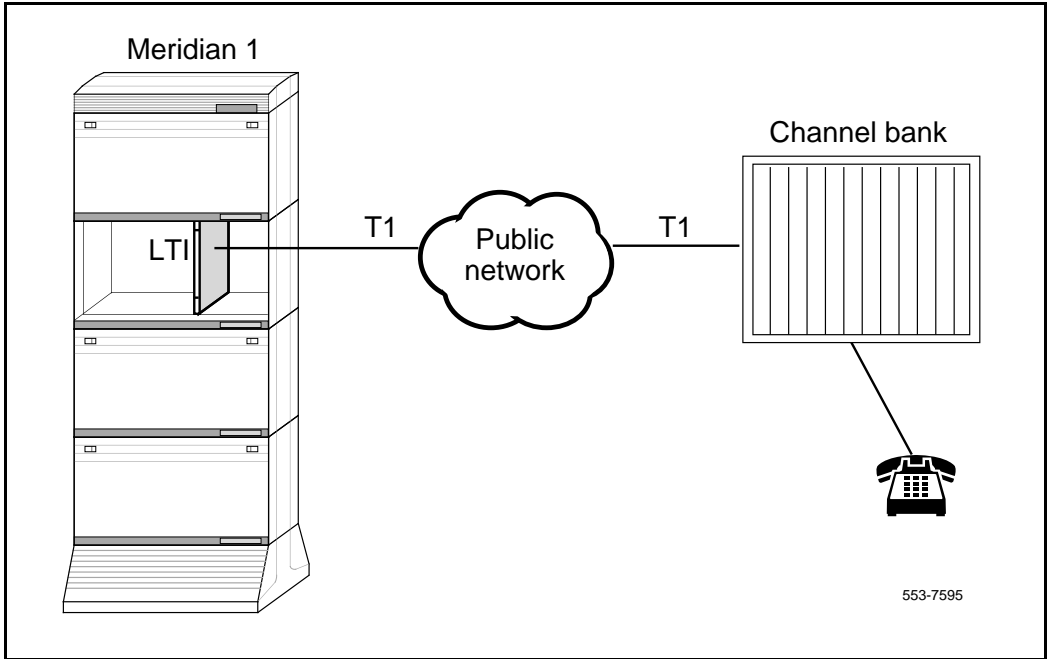

Similarly, the line-side T1 can be used to provide a connection between the Meridian 1 system and a remote Norstar system. See Figure 25. In this case, channel banks would not be required if the Norstar system is equipped with a T1 interface.

Figure 25
Line-side T1 interface connection to Norstar system

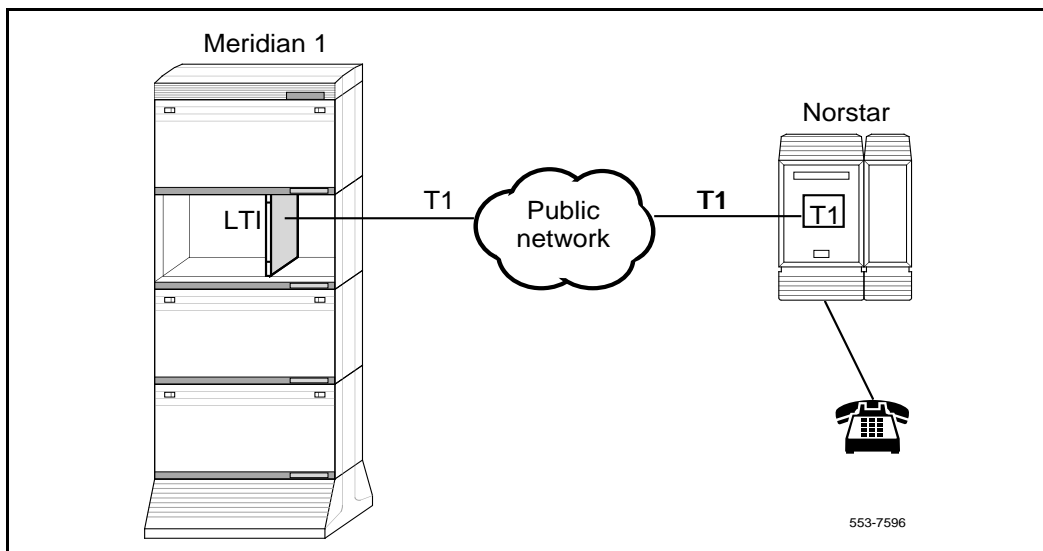

Note: The line-side T1 card audio levels must be considered when determining the appropriateness of an application.

NT5D33 and NTRB34 Line-side E1 Interface Cards

Contents

This section contains information on the following topics:

Introduction	126
Physical description	126
Card connections	127
Faceplate	127
Functional description	131
Overview	131
Card interfaces	133
Electrical specifications	135
E1 channel specifications	136
Power requirements	136
Foreign and surge voltage protections	136
Installation and Configuration	137
Dip switch settings	138
Installation	144
Cabling the line-side E1 card (LEI)	146
Terminal configuration	152
Man-Machine E1 maintenance interface software	155
Description	155
Basic commands	159
Configuring parameters	161
Performance counters and reporting	176

Reference list

The following reference is in this section:

- *Administration (553-3001-311)*

Introduction

The Line-side E1 Interface card (LEI) is an Intelligent Peripheral Equipment (IPE) line card. The LEI card provides an all-digital connection between E1-compatible terminal equipment, such as a voice mail system, and a Meridian 1.

The LEI interfaces one E1 line, carrying 30 channels, to the Meridian 1. The LEI emulates an analog line card to the Meridian 1 software. Each channel is independently configured by software control in the Analog (500/2500-type) Telephone Administration program LD 10. The LEI also comes equipped with a Man-Machine Interface (MMI) maintenance program, which provides diagnostic information regarding the status of the E1 link.

Install the NT5D33 version of the LEI in the NT8D37 IPE module.

Install the NT5D34 version of the LEI in:

- the NTAK11 Option 11C Main Cabinet
- the Option 11C NTAK12 Expansion Cabinet
- the NT1P70 Small Remote IPE Main Cabinet
- the NTAK12 Small Remote IPE Expansion Cabinet

Physical description

The LEI mounts in two consecutive card slots in the IPE shelf. It uses 16 channels on the first slot and 14 channels on the second. The LEI includes a motherboard (31.75 by 25.40 cm. (12.5 by 10 in.) and a daughterboard (5.08 by 15.24 cm. (2 by 6 in.)

Card connections

The LEI uses the NT8D81AA Tip and Ring cable to connect from the IPE backplane to the 25-pair Amphenol connector on the IPE Input/Output (I/O) panel. The I/O panel connector connects to a E1 line, external alarm and an MMI terminal or modem, using the NT5D35 or NT5D36 Line-side I/O cable available from Nortel Networks.

Faceplate

The LEI faceplate is twice as wide as the other standard analog and digital line cards. It occupies two card slots. The LEI faceplate has four LEDs. See Figure 26 on page 128 (IPE version), and Figure 27 on page 129 (Option 11C and small remote cabinet version.)

The LEDs give status indications on the operations as described in Table 29:

Table 29
Line-side E1 card LED operation

LED	Operation
Status	Line card
Red alarm	E1 near end
Yellow alarm	E1 far end
Maint	Maintenance

Figure 26
NT5D33AB Line-side E1 card – faceplate

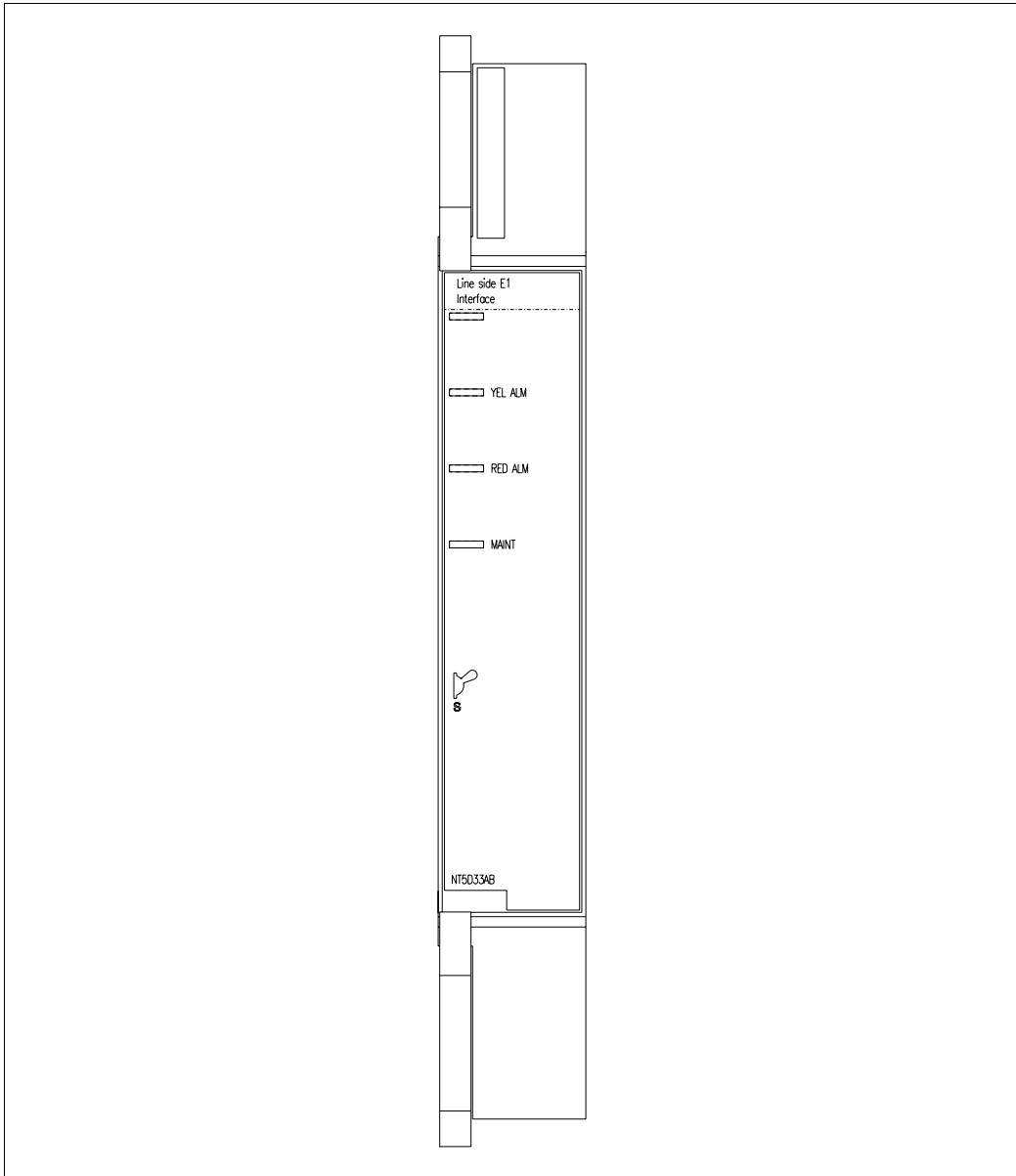
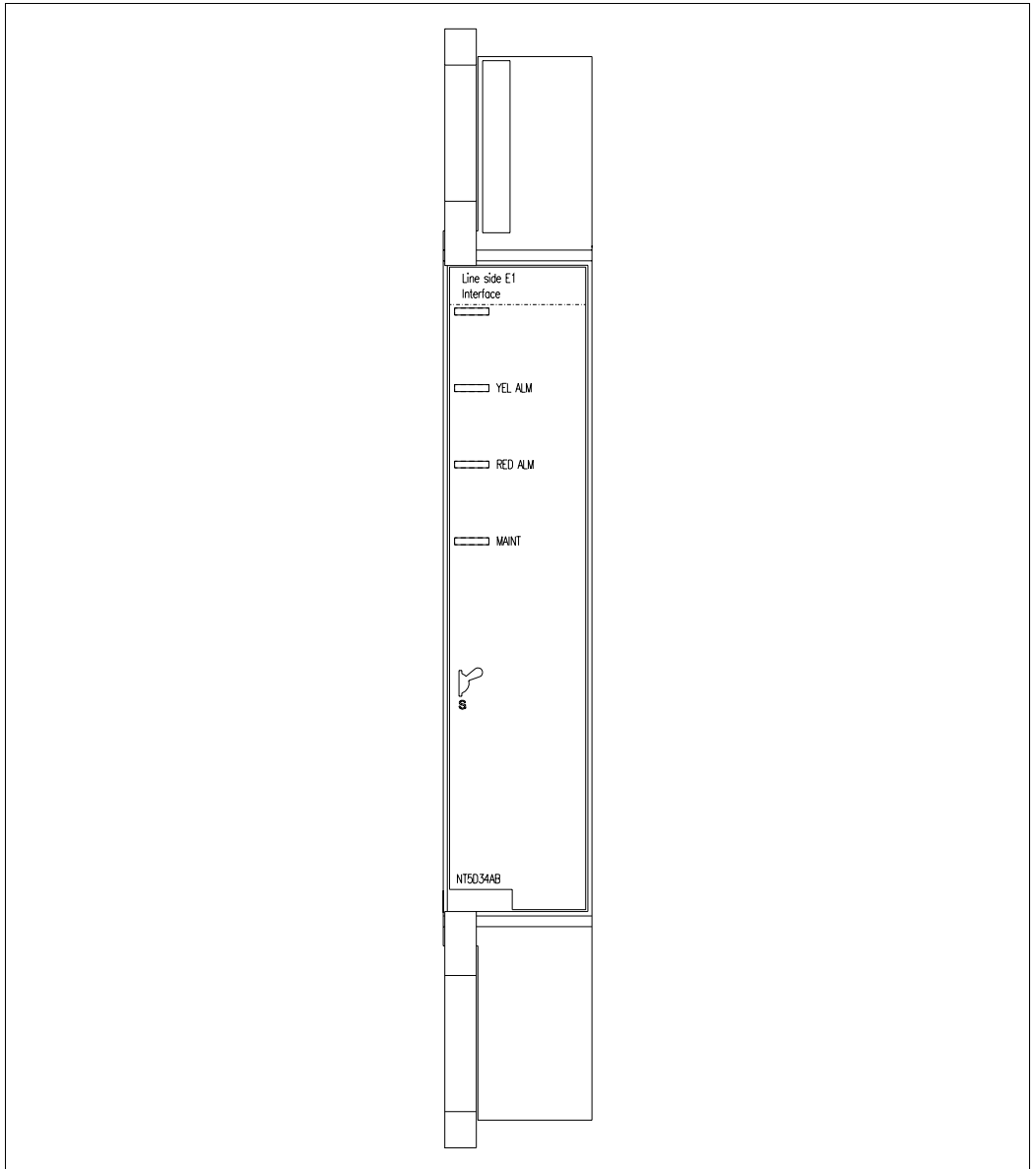

Figure 27
NT5D34AB Line-side E1 line card – faceplate



The **STATUS** LED indicates if the LEI has successfully passed its self test, and therefore, if it is functional. When the card is installed, this LED remains lit for two to five seconds as the self-test runs. If the self-test completes successfully, the LED flashes three times and remains lit. When the card is configured and enabled in software, the LED goes out. If the LED continually flashes or remains weakly lit, replace the card.

The STATUS LED indicates the enabled/disabled status of both card slots of the LEI simultaneously. To properly enable the card, both the motherboard and the daughterboard slots must be enabled. The STATUS LED will turn off as soon as either one of the LEI slots have been enabled. No LED operation will be observed when the second card slot is enabled. To properly disable the card, both card slots must be disabled. The LED will not turn on until both card slots have been disabled.

The **RED ALARM LED** indicates if the LEI has detected an alarm condition from the E1 link. Alarm conditions can include such conditions as not receiving a signal, the signal has exceeded bit error thresholds or frame slip thresholds. See “Man-Machine E1 maintenance interface software” on page 155 for information on E1 link maintenance.

If one of these alarm conditions is detected, this LED will light. Yellow alarm indication is sent to the far end as long as the near end remains in a red alarm condition. Depending on how the Man Machine Interface (MMI) is configured, this LED will remain lit until one the following actions occur:

- If the “Self-Clearing” function is enabled in the MMI, the LED will clear the alarm when the alarm condition is no longer detected. This is the factory default configuration.
- If the “Self-Clearing” function has not been enabled or it has been subsequently disabled in the MMI, the LED alarm indication will stay lit until the command “Clear Alarm” has been typed in the MMI, even though the carrier automatically returned to service when the alarm condition was no longer detected.

The **YELLOW ALARM** LED indicates that the LEI has detected a yellow alarm signal from the terminal equipment side of the E1 link. See “Man-Machine E1 maintenance interface software” on page 155 for information on E1 link maintenance. If the terminal equipment detects a red alarm condition such as not receiving a signal, or the signal exceeds bit-error thresholds or frame-slip thresholds, a yellow alarm signal is sent to the LEI, if the terminal equipment supports this feature. If a yellow alarm signal is detected, this LED will light.

The **MAINT** LED indicates if LEI is fully operational because of certain maintenance commands that are issued through the MMI. See “Man-Machine E1 maintenance interface software” on page 155 for information on E1 link maintenance. If the card detects that tests are being run or that alarms have been disabled through the MMI, this LED will light and will remain lit until these conditions are no longer detected, then it turns off.

Functional description

Figure 28 on page 132 shows a block diagram of the major functions contained on the line-side E1 card. Each of these functions is described on the following pages.

Overview

The Line-side E1 Interface card (LEI) is an IPE line card that provides a cost-effective, all-digital connection between E1-compatible terminal equipment (such as voice mail systems, voice response units, trading turrets, etc.) and a Meridian 1 system. In this application, the terminal equipment can be assured access to analog (500/2500-type) telephone line functionality such as hook flash, SPRE codes and ringback tones generated from the Meridian 1. The LEI supports line supervision features such as loop and ground start protocols. It can also be used in an off-premise arrangement where analog (500/2500-type) telephones are extended over twisted-pair or coaxial E1 with the use of channel bank equipment.

Figure 28
Line-side E1 card – block diagram

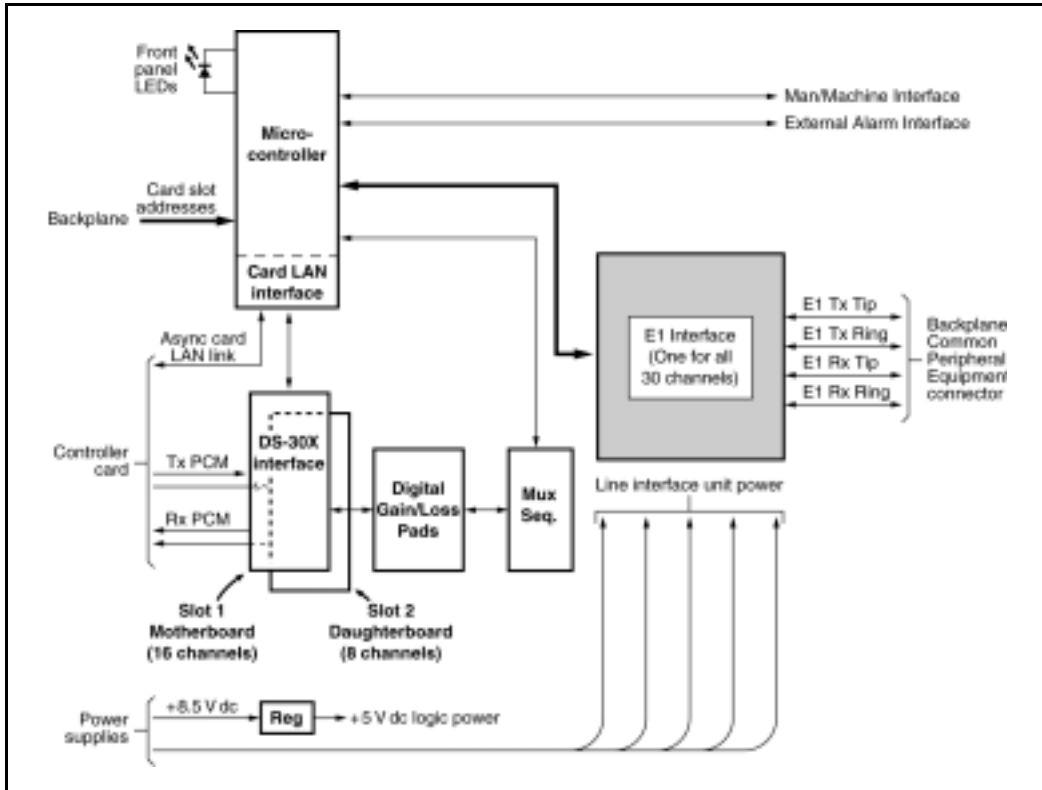

The LEI offers significant improvement over the previous alternatives. For example, if a digital “trunk-side” connection were used, such as with the DTI/PRI interface card, “line-side” functionality would not be supported. Previously, the only way to achieve line-side functionality was to use analog ports and channel bank equipment. With the LEI, a direct connection is provided between the Meridian 1 and the peripheral equipment. No channel bank equipment is required, resulting in a more robust and reliable connection.

When used for connecting to third-party applications equipment, the LEI offers a number of benefits. It is a more cost-effective alternative for connection because it eliminates the need for expensive channel bank equipment. The Line-side E1 supports powerful E1 monitoring, and diagnostic capability. Overall costs for customer applications may also be reduced because the E1-compatible peripheral equipment is often more attractively priced than the analog-port alternatives.

The LEI is compatible with all IPE-based systems and with standard public or private CEPT-type carrier facilities. It supports CRC-4- or FAS-only framing formats as well as AMI or HDB3 coding. Because it uses standard PCM in standard E1 timeslots, existing E1 test equipment remains compatible for diagnostic and fault isolation purposes. A/B Bit signaling may be customized according to the user's system, including the Australian P2 signaling scheme.

Card interfaces

The LEI passes voice and signaling data over DS-30X loops through the DS-30X Interface circuits and maintenance data over the card LAN link.

E1 interface circuit

The LEI contains one E1 line-interface circuit which provides 30 individually configurable voice interfaces to one E1 link in 30 different time slots. The circuit demultiplexes the 2.56 Mbps DS-30X transmit signaling bitstreams from the DS-30X network loop and converts it into 2.048 MHz E1 transmit signaling bitstreams onto the E1 link. It also does the opposite, receiving receive signaling bitstreams from the E1 link and transmitting receive signaling bitstreams onto the DS-30X network loop.

The E1 interface circuit provides the following:

- An industry standard CEPT (0 to 655 feet) interface
- DS-30X signaling protocol into FXO A- and B-channel-associated signaling protocol
- Switch-selectable transmission and reception of E1 signaling messages over an E1 link in either loop or ground start mode
- Switch-selectable call processing between the Australian P2, North American Standard, or other user-configurable schemes

Signaling and control

The LEI also contains signaling and control circuits that establish, supervise, and take down call connections. These circuits work with the system controller to operate the E1 line interface circuit during calls. The circuits receive outgoing call signaling messages from the controller and return incoming call status information to the controller over the DS-30X network loop.

Card control functions

Control functions are provided by a microcontroller and a card LAN link on the LEI. A sanity timer is provided to automatically reset the card if the microcontroller stops functioning for any reason.

Microcontrollers

The LEI contains a microcontroller that controls the internal operation of the card and the serial card LAN link to the controller card. The microcontroller controls the following:

- reporting to the CE CP through the card LAN link
 - card identification (card type, vintage, serial number)
 - firmware version
 - self-test results
 - programmed unit parameter status

- receipt and implementation of card configuration
 - control of the E1 line interface
 - enabling/disabling of individual units or entire card
 - programming of loop interface control circuits for administration of channel operation
 - maintenance diagnostics

- interface with the line card circuit
 - converts on/off-hook, and ringer control messages from the DS-30X loop into A/B bit manipulations for each time slot in the E1 data stream, using channel associated signaling.
- the front panel LED when the card is enabled or disabled by instructions from the NT8D01 controller card.

Card LAN interface

Maintenance data is exchanged with the Common Equipment CPU over a dedicated asynchronous serial network called the Card LAN link. The Card LAN link is described in “Card LAN link” on page 22.

Sanity Timer

The LEI also contains a sanity timer that resets the microcontroller in the event of a loss of program control. If the timer is not properly serviced by the microcontroller, it times out and causes the microcontroller to be hardware-reset. If the microcontroller loses control and fails to service the sanity timer at least once per second, the sanity timer will automatically reset the microcontroller, restoring program control.

Man-Machine Interface

The LEI provides an optional Man-Machine Interface (MMI) that is primarily used for E1 link performance monitoring and problem diagnosis. The MMI provides alarm notification, E1 link performance reporting, and fault isolation testing. The interface is accessed through connections from the I/O panel to a terminal or modem. Multiple cards (up to 64) can be served through one MMI terminal or modem by linking the LEIs through a daisy chain.

The MMI is an optional feature, since all E1 configuration settings are performed through dip switch settings or preconfigured factory default settings. Available MMI commands, and their functionality, are discussed in-depth in “Man-Machine E1 maintenance interface software” on page 155.

Electrical specifications

Table 30 on page 136 provides a technical summary of the E1 line interface. Table 31 on page 136 lists the maximum power consumed by the card.

E1 channel specifications

Table 30 provides specifications for the 30 E1 channels. Each characteristic is set by a dip switch. See “Installation and Configuration” on page 137. for a discussion of the corresponding dip switch settings.

Table 30
Line-side E1 card — line interface unit electrical characteristics

Characteristics	Description
Framing	CRC-4 or FAS, only
Coding	AMI or HDB3
Signaling	Loop or ground start A/B robbed-bit
Distance to LTU	0-199.6 meters (0-655 feet)

Power requirements

Table 31 shows the voltage and maximum current that the LEI requires from the backplane. One NT8D06 Peripheral Equipment Power Supply ac or NT6D40 Peripheral Equipment Power Supply dc can supply power to a maximum of eight LEIs.

Table 31
Line-side E1 card – power required

Voltage	Max. Current
5.0 V dc	1.6 Amp
+15.0 V dc	150 mA
-15.0 V dc	150 mA

Foreign and surge voltage protections

In-circuit protection against power line crosses or lightning strikes is not provided on the LEI. It does, however, have protection against accidental shorts to -52 V dc analog lines.

When the card is used to service off-premise terminal equipment through the public telephone network, install a Line Termination Unit (LTU) as part of the terminal equipment to provide external line protection.

Environmental specifications

Table 32 shows the environmental specifications of the LEI.

Table 32
Line-side E1 card – environmental specifications

Parameter	Specifications
Operating temperature – normal	15° to +30° C (+59° to 86° F), ambient
Operating temperature – short term	10° to +45° C (+50 to 113° F), ambient
Operating humidity – normal	20% to 55% RH (non-condensing)
Operating humidity – short term	20% to 80% RH (non condensing)
Storage temperature	–50° to + 70° C (–58° to 158° F), ambient
Storage humidity	5% to 95% RH (non-condensing)

Installation and Configuration

Installation and configuration of the LEI consists of six basic steps:

- 1** Set the dip switches on the LEI for the call environment.
- 2** Install the LEI into the selected card slots.
- 3** Cable from the I/O panel to the LTU, MMI terminal or modem (optional), external alarm (optional), and other LEIs for daisy chaining use of MMI terminal (optional).
- 4** Configure the MMI terminal.
- 5** Configure the LEI through the Meridian 1 software and verify self-test results.
- 6** Verify initial E1 operation and configure MMI (optional).

Steps 1-5 are explained in this section. Step 6 is covered in “Man-Machine E1 maintenance interface software” on page 155.

Dip switch settings

Begin the installation and configuration of the LEI by selecting the proper dip switch settings for the environment. The LEI contains two dip switches, each containing eight switch positions. They are located in the upper right corner of the motherboard circuit card as shown in Figure 29 on page 139. The settings for these switches are shown in Tables 33 through 36.

When the line-side E1 card is oriented as shown in Figure 29, the dip switches are ON when they are up, and OFF when they are down. The dip switch settings configure the card for the following parameters:

MMI port speed selection

This dip switch setting selects the appropriate baud rate for the terminal or modem (if any) that is connected to the MMI.

Line Supervisory Signaling protocol

The LEI is capable of supporting loop start or ground start call processing modes. Make the selection for this dip switch position based on what type of line signaling the Customer Premise Equipment (CPE) supports.

Address of LEI to the MMI

The address of the LEI to the MMI is made up of two components:

- the address of the card within the shelf
- the address of the shelf in which the card resides.

These two addresses are combined to create a unique address for the card. The MMI reads the address of the card within the shelf from the card firmware; the address of the shelf must be set by this dip switch.

The shelf address dip switch can be from 0 – 15, 16 being the maximum number of Line-side E1 IPE shelves (a maximum of 64 LEI cards) capable of daisy chaining to a single MMI terminal. For ease, it is recommended that this address be set the same as the address of the peripheral controller identifier in LD 97 for type: XPE. However, this is not mandatory, and, since the dip switch is limited to 16, this will not always be possible.

Figure 29
Line-side E1 card – E1 protocol dip switch locations

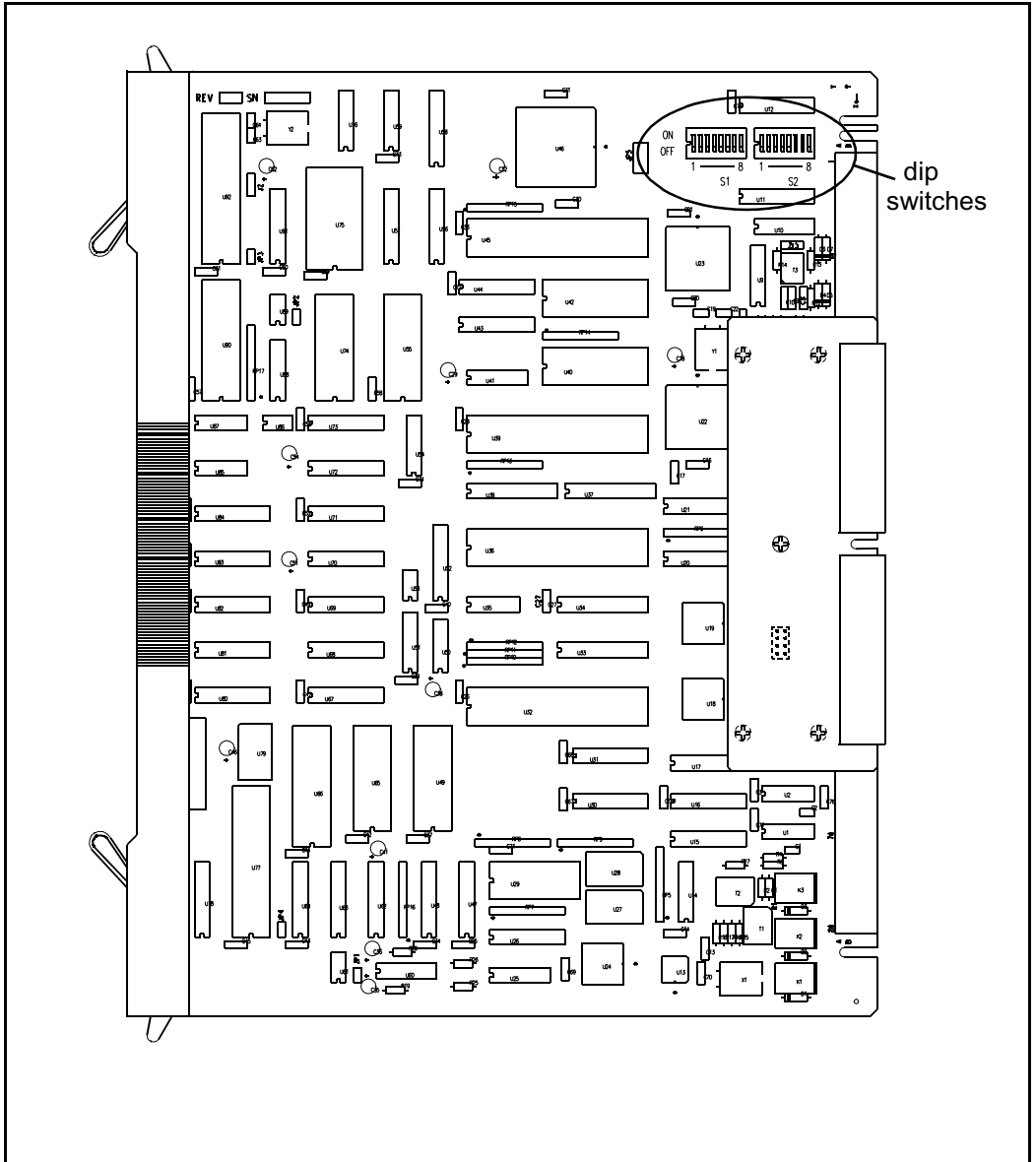

E1 framing

The LEI is capable of interfacing with LTU equipment either in CRC-4 or FAS only framing mode. Make the selection for this dip switch position based on what type of framing the LTU equipment supports.

E1 Coding

The LEI is capable of interfacing with LTU equipment using either AMI or HDB3 coding. Make the selection for this dip switch position based on the type of coding the LTU equipment supports.

Line supervision on E1 failure

This setting determines in what state all 30 LEI ports will appear to the Meridian 1 in case of E1 failure. Ports can appear to the Meridian 1 as either in the “on-hook” or “off-hook” states on E1 failure.

Note: All idle LEI lines will go off-hook and seize a Digitone Receiver when the off-hook line processing is invoked on E1 failure. This may prevent DID trunks from receiving incoming calls until the LEI lines time-out and release the DTRs.

Daisy-Chaining to MMI

If two or more LEIs will be installed and the MMI used, daisy-chain the cards together to use one MMI terminal or modem. Make the selection for this dip switch position based on how many LEIs are being installed.

MMI Master or Slave

This setting is used only if daisy-chaining the cards to the MMI terminal or modem. It determines whether this card is a master or a slave in the daisy chain. Select the master setting if there are no LEIs between this card and the MMI terminal or modem. Select the slave setting if there are other cards in the daisy chain between this card and the MMI.

Tables 33 through 35 show the dip switch settings for Switch #1. Table 36 on page 143 shows the dip switch settings for Switch #2.

Table 33
Line-side E1 card – Switch #1 dip switch settings

Characteristic	Selection	Switch Position	Switch Setting	Factory Default
MMI port speed selection	1200 baud	1	ON	OFF
	2400 baud	1	OFF	
E1 signaling	Ground start	2	ON	OFF
	Loop start	2	OFF	
IPE Shelf address for LEI	See Table 35	3	See Table 35	OFF
		4		OFF
		5		OFF
Card type for ringer allocation	XTI = 19	6	OFF	OFF
	XMLC = 18	7		
E1 signaling	See Table 34	8	OFF	OFF

When dip switch #1, positions 2 and 8 are set to “Table,” AB Bits are configured by the user through the Set Mode MMI command (see “Set Mode” on page 167). Otherwise, the signaling scheme selected by dip switch 1, positions 2 and 8 will be used.

Table 34
Line-side E1 card – signaling-type dip switch settings

Switch #1			
Characteristic	Selection	Position 2	Position 8
Signaling Type	Loop start	OFF	OFF
	Ground start	ON	OFF
	Australian P2	OFF	ON
	Table	ON	ON

Table 35
Line-side E1 card – XPEC address dip switch settings (Switch S1, positions 3-6)

XPEC Address	S1 Switch Position 3	S1 Switch Position 4	S1 Switch Position 5	S1 Switch Position 6
00	OFF	OFF	OFF	OFF
01	ON	OFF	OFF	OFF
02	OFF	ON	OFF	OFF
03	ON	ON	OFF	OFF
04	OFF	OFF	ON	OFF
05	ON	OFF	ON	OFF
06	OFF	ON	ON	OFF
07	ON	ON	ON	OFF
08	OFF	OFF	OFF	ON
09	ON	OFF	OFF	ON
10	OFF	ON	OFF	ON
11	ON	ON	OFF	ON
12	OFF	OFF	ON	ON
13	ON	OFF	ON	ON
14	OFF	ON	ON	ON
15	ON	ON	ON	ON

Table 36
Line-side E1 card – E1 Switch 2 (S2) dip switch settings

Characteristic	Selection	Switch Position	Switch Setting	Factory Default
E1 framing	CRC-4 Disabled	1	ON	OFF
	CRC-4 Enabled	1	OFF	
E1 coding	AMI	2	ON	OFF
	HDB3	2	OFF	
NOT USED	leave ON	3	ON	ON
	leave OFF	4	OFF	OFF
	leave OFF	5	OFF	OFF
Line processing on E1 link failure	On-hook	6	ON	ON
	Off-hook	6	OFF	
Daisy-chaining to MMI	YES	7	ON	OFF
	NO	7	OFF	
MMI master or slave	Master	8	ON	ON
	Slave	8	OFF	

After the card has been installed, display the dip switch settings using the MMI command **Display Configuration (D C)**. See “Man-Machine E1 maintenance interface software” on page 155 for details on this and the rest of the available MMI commands.

Installation

Because of the wiring in some of the Meridian 1 modules and cabinets, the LEI will only work in certain card slot pairs. These restrictions depend on the type of module or cabinet. In all other modules or cabinets where the conditions listed below do not exist, the LEI will work in any two adjacent card slots.

- In the NTAK12 Small Remote IPE Expansion Cabinet only card slots 10-15 are available
- In the NT8D37 IPE Module, if the 25-pair I/O connectors are partially split between adjacent IPE card slots, the LEI works only in card slots where Unit 0 of the motherboard card slot appear on the first pair of the 25-pair I/O connector.

If installing the LEI into the NT8D37 IPE module, determine the vintage level model. Certain vintage levels have dedicated 25-pair I/O connectors only for card slots 0, 4, 8, and 12. These vintage levels are cabled with only 16 pairs of wires from each card slot to the I/O panel. Some of the 25-pair I/O connectors are split between adjacent card slots.

Other vintage levels cable each card slot to the I/O panel using a unique, 24-pair connector on the I/O panel. In these vintage levels, the LEI can be installed in any available pair of card slots. However, because of the lower number of wire pairs cabled to the I/O panel in the lower vintage level, only certain card slots are available to the LEI.

See Table 37 for the vintage level information for the NT8D37 IPE modules

Table 37
Line-side E1 card – NT8D37 IPE Module vintage level port cabling

Vintage Level	Number of ports cabled to I/O panel
NT8D37BA	30 ports
NT8D37DE	16 ports
NT8D37EC	30 ports

Available and restricted card slots in the NT8D37 IPE Module

If installing the LEI into an NT8D37 IPE Module, the card slots available depend on the vintage level module.

Vintage levels cabling 30 ports:

For modules with vintage levels that cabled 30 ports to the I/O panel, the LEI can be installed in any pair of card slots 0-15.

Vintage levels cabling 16 ports:

For modules with vintage levels that cable 16 ports to the I/O panel, the LEI can be installed into the card slot pairs shown in the following card slots:

Available: Motherboard/Daughterboard
 0 and 1
 1 and 2
 4 and 5
 5 and 6
 8 and 9
 9 and 10
 12 and 13
 13 and 14

LEIs must **not** be installed into the following card slot pairs:

Restricted: Motherboard/Daughterboard
 2 and 3
 3 and 4
 6 and 7
 10 and 11
 11 and 12
 14 and 15

If the LEI must be installed into one of the restricted card slot pairs, rewire the IPE module card slot to the I/O panel by installing an additional NT8D81 cable from the LEI motherboard slot to the I/O panel, and re-arranging the three backplane connectors for the affected card slots. This will permit the connection of the NT5D35AA or NT5D36AA Line-side E1 card carrier and maintenance external I/O cable at the IPE and CE/PE module I/O panel connector for card slots that are otherwise restricted.

Alternatively, all LEI connections can be made at the main distribution frame instead of connecting the NT5D35AA or NT5D36AA Line-side E1 card external I/O cable at the I/O panel. This eliminates these card slot restrictions.

Cabling the line-side E1 card (LEI)

After the dip switches are set and the LEI installed into the selected card slots, the LEI can be cabled to the LTU equipment, the MMI terminal or modem (optional), an external alarm (optional), and other LEIs for daisy chaining use of the MMI terminal (optional).

The LEI is cabled from its backplane connector through connections from the motherboard circuit card only to the I/O panel on the rear of the IPE module. No cable connections are made from the daughterboard circuit card. The connections from the LEI to the I/O panel are made with the NT8D81AA Tip and Ring cables provided with the IPE module.

Cabling from the I/O panel with the NT5D35AA or NT5D36AA Line-Side E1 I/O cable

In a twisted-pair E1 installation, make the connection from the I/O panel to the E1 link and other external devices with the NT5D35AA Line-side E1 I/O cable.

This cable consists of a 25-pair amphenol connector (P1) on one end which plugs into the I/O panel. The other end has four connectors:

- 1 a DB15 male connector (P2), which plugs into the E1 line
- 2 a DB9 male connector (P3), which plugs into an external alarm system
- 3 a second DB9 male connector (P5), which connects to an MMI terminal or modem
- 4 a DB9 female connector (P4), which connects to the next LEI's P4 connector for MMI daisy chaining

In a coaxial E1 installation, make the connection from the I/O panel to the E1 link and other external devices through the NT5D36AA Line-side E1 I/O cable.

This cable consists of a 25-pair amphenol connector (P1) on one end which plugs into the I/O panel. The other end has 4 connectors:

- 1 a DB15 female connector (P2) with an adapter that breaks out Tx (transmit) and Rx (receive) connectors, which that plug into the E1 line
- 2 a DB9 male connector (P3), which plugs into an external alarm system
- 3 a second DB9 male connector (P5), which connects to an MMI terminal or modem
- 4 a DB9 female connector (P4), which connects to the next LEI's P4 connector for MMI daisy chaining. The Tx marking on the adapter at P2 is the LEI output. The E1 data stream coming from the network into the LEI connects at the Rx coaxial connector

Table 38 shows the pin assignments of the LEI backplane and I/O Panel.

Table 38
Line-side E1 card – LEI backplane and I/O panel pinouts (Part 1 of 2)

Backplane connector pin	I/O Panel connector pin	Signal
12A	1	E1 Tip, Receive data
12B	26	E1 Ring, Receive data
13A	2	E1 Tip, Transmit data
13B	27	E1 Ring, Transmit data
14A	3	Alarm out, normally open
14B	28	Alarm out, common
15A	4	Alarm out, normally closed
15B	29	No connection
16A	5	No connection

Table 38
Line-side E1 card – LEI backplane and I/O panel pinouts (Part 2 of 2)

Backplane connector pin	I/O Panel connector pin	Signal
16B	30	Away from MMI terminal, receive data
17A	6	Away from MMI terminal, transmit data
17B	31	Toward MMI terminal, transmit data
18A	7	Toward MMI terminal, receive data
18B	32	Daisy chain control 2
19A	8	Daisy chain control 1
19B	33	Ground

Table 39 shows the pin assignments from the I/O panel relating to the pin assignments of the Line-Side E1 I/O cable.

Table 39
Line-side E1 card – Line-Side E1 I/O cable pinouts (Part 1 of 2)

I/O Panel Connector Pin	Lead Designations	LEI Connector Pin	LEI Cable Connector to External Equipment
1	E1 Tip Receive data	11	DB15 male to E1 (P2). LEI is CPE transmit and receive to network
26	E1 Ring Receive data	3	
2	E1 Tip Transmit data	1	
27	E1 Ring Transmit data	9	
3	Alarm out, common	1	DB9 male to external alarm (P3)
28	Alarm out (normally open)	2	

Table 39
Line-side E1 card – Line-Side E1 I/O cable pinouts (Part 2 of 2)

I/O Panel Connector Pin	Lead Designations	LEI Connector Pin	LEI Cable Connector to External Equipment
4	Alarm out (normally closed)	3	
7	Toward MMI terminal, receive data	2	
31	Toward MMI terminal, transmit data	3	DB9 male toward MMI (P5). Wired as DCE. Data is transmitted on pin 2 (RXD) and received on pin 3 (TXD)
33	Ground	5	
8	Control 1	7	
32	Control 2	9	
33	Ground	5	DB9 female away from MMI terminal (P4)
8	Control 1	7	
32	Control 2	9	
30	Away from MMI terminal, transmit data	3	
6	Away from MMI terminal, receive data	2	

E1 Connections

For twisted-pair installations, E1 signaling for all 30 channels is transmitted over P2 connector pins 1, 3, 9, and 11, as shown in Table 39 on page 148.

Plug the DB 15 male connector labeled “P2” into the E1 link. E1 transmit and receive pairs must be turned over between the LEI and the CPE that is hardwired without carrier facilities. If the LEI is connected through E1 carrier facilities, the transmit and receive pairs must be wired straight through to the RJ48 at the Telco demarc, the LTU, or other E1 carrier equipment. The E1 CPE at the far-end will likewise have transmit and receive wired straight from the RJ48 demarc at the far-end of the carrier facility.

For 75 ohm coaxial installations, E1 signaling for all 30 channels is transmitted over P2 connector pins 1, 3, 9, and 11 through an adapter and out two coaxial connectors Tx (transmit) and Rx (receive). Tx is the LEI output, and Rx is the LEI input from the E1 stream. E1 transmit and receive pairs must be turned over between the LEI and the CPE that is hardwired without carrier facilities. If the LEI is connected through E1 carrier facilities, the transmit and receive pairs must be wired straight through to the RJ48 at the Telco demarc, the LTU, or other E1 carrier equipment. The E1 CPE at the far end will likewise have Tx and Rx wired straight from the RJ48 demarc at the far end of the carrier facility.

External Alarm Connections

P3 connector pins 1, 2 and 3 can be plugged into any external alarm-sensing hardware. Plug the DB9 male connector labeled “P3” into an external alarm. These connections are optional, and the LEI functionality is not affected if they are not made.

The MMI monitors the E1 link for specified performance criteria and reports on problems detected. One of the ways it can report information is through this external alarm connection. If connected, the LEI’s microprocessor will activate the external alarm hardware if it detects certain E1 link problems it has classified as alarm levels 1 or 2. See “Man-Machine E1 maintenance interface software” on page 155 for a detailed description of alarm levels and configuration. If an alarm level 1 or 2 is detected by the MMI, the LEI will close the contact that is normally open, and will open the contact that is normally closed. The MMI command “Clear Alarm” will return the alarm contacts to their normal state.

MMI Connections

P5 connector pins 2, 3, 5, 7 and 9 are used to connect the LEI to the MMI terminal, connecting LEIs in a daisy chain for access to a shared MMI terminal. When logging into a LEI, “control 2” is asserted by that card, which informs all of the other cards not to talk on the bus, but rather to pass the data straight through. The pins labeled “control 1” are reserved for future use. As with the external alarm connections, MMI connections are optional. Up to 128 LEIs can be linked, located in up to 16 separate IPE shelves, to one MMI terminal using the daisy chain approach.

If only **one** LEI is will be installed, cable from the DB9 male connector labeled “P5” (toward MMI terminal) to one of the COM ports on the back of any TTY, a PC running a terminal emulation program, or a modem. For installations of only one card, no connection is made to the DB9 female connector labeled “P4” (away from MMI terminal).

If **two or more** LEIs are being installed into the Meridian 1 system, the MMI port connections can be daisy-chained together so that only one MMI terminal is required for up to 128 LEIs. See Figure 30 on page 152. Cards can be located in up to 15 separate IPE shelves. Start with any card slot in the IPE shelf and connect to any other card slot. Connected card slots do not need to be consecutive.

Follow this procedure for connecting two or more LEIs to the MMI terminal:

- 1** Cable the DB9 male connector labeled “P5” (toward MMI terminal) to one of the COM ports on the back of any TTY, a PC running a terminal emulation program, or a modem.
- 2** Make the connection from the first card to the second card by plugging the DB9 female connector labeled “P4” (away from MMI terminal) from the *first* card into the DB9 male connector of the second card labeled “P5” (toward MMI terminal).
- 3** Repeat step 2 for the remaining cards.
- 4** At the last card of the daisy chain, make no connection from the DB9 female connector labeled “P4” (away from MMI terminal).
- 5** If two LEIs are too far apart to connect the “P4” and “P5” connectors connect them with an off-the-shelf DB9 female to DB9 male straight-through extension cable, available at any PC supply store.

Figure 30
Line-side E1 card – connecting two or more cards to the MMI

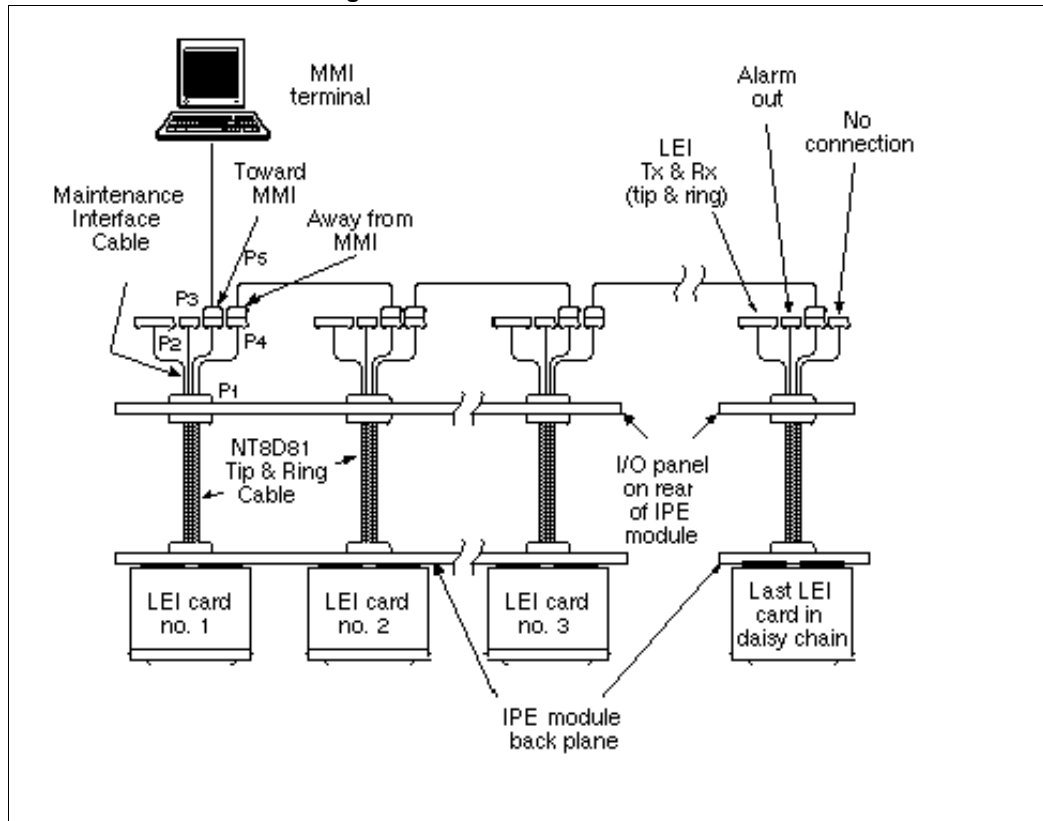

Terminal configuration

For the MMI terminal to be able to communicate to the LEI, the interface characteristics must be set to:

- speed – 1200 or 2400 bps
- character width – 7 bits
- parity bit – mark

- stop bits – one
- software handshake (XON/XOFF) – off

Software Configuration

Although much of the architecture and many features of the LEI card are different from the analog line card, the LEI has been designed to emulate an analog line card to the Meridian 1 software. Because of this, the LEI software configuration is the same as for two adjacent analog line cards.

All 30 E1 channels carried by the LEI are individually configured using the analog (500/2500-type) Telephone Administration program LD 10. Use Table 39 on page 148 to determine the correct unit number and *Administration* (553-3001-311) for LD 10 service-change instructions.

LEI circuitry routes 16 units (0 – 15) on the motherboard and 14 (0 – 13) units on the daughterboard to 30 E1 channels. The motherboard circuit card is located in the left card slot, and the daughterboard circuit card is located in right card slot. For example, if installing the LEI into card slots 0 and 1, the motherboard would reside in card slot 0 and the daughterboard would reside in card slot 1. In order to configure the terminal equipment through the switch software, the E1 channel number will need to be cross-referenced to the corresponding card unit number. This mapping is shown in Table 40.

Table 40
Card unit number to E1 channel mapping (Part 1 of 2)

TN		E1 Channel Number
Motherboard	0	1
Motherboard	1	2
Motherboard	2	3
Motherboard	3	4
Motherboard	4	5
Motherboard	5	6
Motherboard	6	7
Motherboard	7	8

Table 40
Card unit number to E1 channel mapping (Part 2 of 2)

TN		E1 Channel Number
Motherboard	8	9
Motherboard	9	10
Motherboard	10	11
Motherboard	11	12
Motherboard	12	13
Motherboard	13	14
Motherboard	14	15
Motherboard	15	17
Daughterboard	0	18
Daughterboard	1	19
Daughterboard	2	20
Daughterboard	3	21
Daughterboard	4	22
Daughterboard	5	23
Daughterboard	6	24
Daughterboard	7	25
Daughterboard	8	26
Daughterboard	9	27
Daughterboard	10	28
Daughterboard	11	29
Daughterboard	12	30
Daughterboard	13	31

Disconnect supervision

The LEI supports far-end disconnect supervision by opening the tip side toward the terminal equipment upon the Meridian 1 system's detecting a disconnect signal from the far-end on an established call. The Supervised Analog Line feature (SAL) must be configured in LD 10 for each LEI port. At the prompt FTR respond:

OSP <CR>

Against FTR respond:

ISP <CR>

The LEI treats OSP and ISP for both originating and terminating calls as hook flash disconnect supervision, also known as cut-off disconnect. Originating calls are outgoing from the terminal equipment. Terminating calls are incoming to the terminal equipment. The LEI does not support battery reversal answer and disconnect supervision on originating calls.

After the software is configured, power-up the card and verify the self-test results. The **STATUS** LED on the faceplate indicates whether or not the LEI has successfully passed its self test, and is, therefore, functional. When the card is installed, this LED remains lit for two to five seconds as the self-test runs. If the self-test completes successfully, the LED flashes three times and remains lit. When the card is configured and enabled in software, the LED goes out. The LED will go out if either the motherboard or daughterboard is enabled by the software. If the LED continually flashes or remains weakly lit, replace the card.

Man-Machine E1 maintenance interface software

Description

The Man-Machine Interface (MMI) provides E1-link diagnostics and historical information for the LEI system. See "Installation and Configuration" on page 137 for instructions on how to install the cabling and configure the terminal for the MMI. The following sections will describe the options available through the LEI's MMI terminal and will explain how to set-up, configure, and use the MMI.

The MMI provides the following maintenance features:

- configurable alarm parameters
- E1-link problem indicator
- current and historical E1-link performance reports
- E1 verification and fault isolation testing
- configuration of A/B bits (North American Standard, Australian P2, or customized settings are available)

Alarms

The MMI may be used to activate alarms for the following E1-link conditions:

- excessive bit-error rate,
- frame-slip errors,
- out-of-frame,
- loss-of-signal, and
- blue alarm.

Pre-set thresholds and error durations trip LEI alarm notifications. For descriptions of each of these E1-link alarm conditions, see “Performance counters and reporting” on page 176. For instructions on how to set alarm parameters, see “Set Alarm” on page 162. For information on accessing alarm reporting, see “Display Alarms” on page 174, “Display Status” on page 175 and “Display Performance” on page 177.

Two levels of alarm severity exist for bit errors. Different threshold and duration settings must be established for each level.

When the first level of severity is reached (alarm level 1), the MMI causes the following:

- the external alarm hardware activates t
- he RED ALARM LED on the faceplate will be lit

- an alarm message will be displayed on the MMI terminal
- an entry will be created in the alarm log and printed to the MMI port

When the second level of severity is reached (alarm level 2), the MMI will perform all functions performed at alarm level 1. In addition, the LEI enters line-conditioning mode. In this mode, the LEI sends either “on-hook” or “off-hook” signals for all 30 ports to the Meridian 1, depending on how the dip switch for line processing is set (dip switch 2, position 6). See Table 36 on page 143.

If the MMI detects E1-link failures for any of the other conditions monitored (out-of-frame, excess frame slips, loss-of-signal, and blue alarm condition), the LEI automatically performs all alarm level 2 functions. The MMI also sends a yellow alarm to the far-end LTU. Alarms may be set to self-clear when the alarm condition is no longer detected. See “Set Clearing” on page 166.

All alarms activated produce a record in the alarm log. The alarm log maintains records for the most recent 100 alarms, and can be displayed, printed, and cleared. The alarm log displays or prints the alarms in descending chronological order, beginning with the most recent alarm. Notifications in the alarm log include the date and time of the alarm’s occurrence.

E1 Performance Counters and Reports

The MMI maintains performance error counters for the following E1 conditions:

- errored seconds
- bursty seconds
- unavailable seconds
- framer-slip seconds
- loss-of-frame seconds

The MMI retains E1 performance statistics for the current hour, and for each hour for the previous 24. For descriptions of these performance error counters and instructions on how to create a report on them and clear them, see “Performance counters and reporting” on page 176.

E1 Verification and Fault Isolation Testing

The MMI enables various tests to be performed that either verify that the E1 is working adequately, or help to isolate a problem to the LEI, the E1 link, or the CPE. For descriptions of all of these tests and instructions on how to run them, see “Testing” on page 179.

Login and Password

The MMI can be accessed through any TTY, PC running a terminal emulation program, or modem. After installing the MMI terminal and card cables, the MMI can be configured.

For single-card installations, it is accessed by entering **L<CR>** to login.

For multiple-card installations connected in a daisy chain, it is accessed by entering **L <address>**, where the four-digit address is a combination of the two-digit address of the IPE shelf as set by dip switch positions on the card Switch 1, positions 3-6, plus the address of the card slot the motherboard occupies. See Table 37, “Line-side E1 card – NT8D37 IPE Module vintage level port cabling,” on page 144.

For example, to login to a card located in shelf 13, card slot 4, type:

L 13 4 <CR>

Spaces are inserted between the login command (L), the shelf address, and the card slot address.

The MMI prompts for a password. The password is “**LEILINK**,” and it must be typed in all capital letters.

After logging in, the prompt looks like this:

LEI::> (for single-card installations)

LEI::ss cc (for multi-card installations, where ss represents the shelf address and cc represents the card slot address.)

Basic commands

MMI commands can now be executed. The seven basic commands are:

- Help
- Alarm
- Clear
- Display
- Set
- Test
- Quit

Type **?<CR>** to list these commands, along with an explanation of their usage. A screen similar to Figure 31 will appear. The help screen will also appear by typing **H<CR>**, or **HELP<CR>**.

Figure 31
HELP (H, ?) screen

```
ALARM  USAGE: Alarm [Enable | Disable]
CLEAR  USAGE: Clear [Alarm] | [Error counter] [Log]
DISPLAY USAGE: Display [Alarm | Status | Perform | History] [Pause]
HELP   USAGE: Help | ?
SET    USAGE: Set[Time | Date | Alarm | Clearing | Name Memory | Mode | Simple]
TEST   USAGE: Test [Carrier All]
QUIT   USAGE: Quit

Notation Used:
CAPS - Required Letters      [ ] - Optional | - Either/Or
```

Each of these commands can be executed by entering the first letter of the command or by entering the entire command. Commands with more than one word are entered by entering the first letter of the first word, a space, and the first letter of the second word or by entering the entire command. Table 41 shows all possible MMI commands in alphabetical order. These commands are also described later in this section.

Table 41
MMI commands and command sets (Part 1 of 2)

Command	Description
A D	Alarm Disable. Disables all alarms.
A E	Alarm Enable. Enables all alarms.
C A	Clear Alarm. Clears all alarms, terminates time processing, and resets the E1 bit error rate and frame slip counters.
C A L	Clear Alarm Log. Clears alarm log.
C E	Clear Error. Clears the E1 error counter.
D A(P)	Display Alarms. Displays the alarm log, which is a list of the 100 most recent alarms with time and date stamps. (Momentarily stop the scrolling display by typing P. Continue scrolling by typing any other key.)
D C(P)	Display Configuration. Displays the configuration settings for the LEI(s), single- or multiple-card system. Display includes each card's serial number, MMI firmware version, date and time, alarm disable/enable setting, self-clearing disable/enable setting, values entered through the Set Configuration command, and dip switch settings. (Momentarily stop the scrolling display by typing P. Continue scrolling by typing any other key.)
D H(P)	Display History. Displays performance counters for the past 24 hours. (Momentarily stop the scrolling display by typing P. Continue scrolling by typing any other key.)
D P	Display Performance. Displays performance counters for the current hour.
D S(P)	Display Status. Displays carrier status, including alarm state and, if active, alarm level. (Momentarily stop the scrolling display by typing P. Continue scrolling by typing any other key.)
H or ?	Help. Displays the Help screen.

Table 41
MMI commands and command sets (Part 2 of 2)

Command	Description
L	Login. Logs into the MMI terminal in a single-LEI system.
Lxx	Login. Logs into the MMI terminal in a daisy-chained system, where xx represents the address of the card to be configured.
Q	Quit. Logs out of the MMI terminal. Note: If it is a daisy-chained system, be certain to log out when finished with configuration. In a daisy-chained system, only one card may occupy the bus at a given time and all other LEIs will be unable to notify the MMI of alarms unless logged-out of configuration mode.
S A	Set Alarm. Sets alarm parameters, such as the allowable bit-errors per second, threshold, and alarm duration.
S C	Set Clearing. Sets the alarm self-clearing function, "enable" or "disable."
S D	Set Date. Sets the date or verifies the current date.
S M	Set Mode. Sets the A/B Bits mode.
S S	Set Simple. Sets whether or not the LEI waits for the terminal equipment to return an idle-state message before returning the channel to idle at call disconnect from the far-end.
S T	Set Time. Sets the time or verifies current time.
T	Test. Initiates the E1 carrier test function. To terminate a test in-process, enter the STOP TEST command at any time.

Configuring parameters

The MMI has been designed with default settings so that no configuration is necessary. However, it can be configured based on the call environment.

Set Time

Before beginning to configure the MMI, login to the system and verify the current time. Do this by entering the **Set Time (S T)** command. The MMI displays the time it has registered. Enter a new time or hit **Enter** to leave it unchanged. The time is entered in the "hh:mm:ss," the 24-hour, or military, format.

Set Date

Verify the current date. Do this by entering the **Set Date (S D)** command. The MMI then displays the date it has registered. Enter a new date or hit **Enter** to leave it unchanged. The date is entered in the “mm/dd/yy” format.

Set Alarm

The **Set Alarm (S A)** command sets the parameters by which an alarm is activated and the duration of the alarm after it is activated. There are three alarm levels as described below:

- **Alarm Level 0 (AL0)** consists of activity with an error threshold below the AL1 setting, which is a satisfactory condition and no alarm is activated.
- **Alarm Level 1 (AL1)** consists of activity with an error threshold above the AL1 setting, but below the AL2 setting that is deemed to be of minor importance. In this situation, the external alarm hardware is activated by closing the normally open contact, the RED ALARM LED on the faceplate lights, and an alarm message is created in the alarm log and the MMI terminal.
- **Alarm Level 2 (AL2)** consists of activity with an error threshold above the AL2 setting which is deemed to be of major importance. In this situation, the following happens:
 - the external alarm hardware is activated by closing the normally open contact
 - the RED ALARM LED on the faceplate lights
 - an alarm message is created in the alarm log and the MMI terminal
 - the Line-side E1 card enters line-conditioning mode
 - a yellow alarm message is sent to the CPE/LTU

Line processing sends the Meridian 1 either all “on-hook” or all “off-hook” signals, depending on the dip switch setting of the card. See Table 36, “Line-side E1 card – E1 Switch 2 (S2) dip switch settings,” on page 143.

When the **Set Alarm** command is selected, the prompt appears for setting the threshold level and duration for alarm levels 1 and 2.

The E1 link processes at a rate of approximately 2.0 mb/s. The threshold value indicates the ratio of the total number of bits that must be detected as being in error per second before the LEI activates an alarm. It can be set between 3 and 9 and can be different for each alarm level. Any other value entered will cause the MMI to display a "Parameter Invalid" message. The digit entered as the threshold value is a number representing a negative power of 10 as shown in Table 42 on page 163.

Note: The error-rate threshold for a level 2 alarm must be greater (a smaller power of 10) than for a level 1 alarm. Remember that the numbers being represented are negative numbers. Since 3 represents -3 , and 4 represents -4 , 4 represents a smaller number than 3 does.

Table 42
E1 bit error rate threshold settings

Alarm threshold bit errors per second in power of 10	Threshold to set alarm	Allowable Duration Periods
10^{-3}	2,000/ second	1-21 seconds
10^{-4}	200/second	1-218 seconds
10^{-5}	20/second	1-2148 seconds
10^{-6}	2.0/second	1-3600 seconds
10^{-7}	2.0/10 seconds	10-3600 seconds
10^{-8}	2.0/100 seconds	100-3600 seconds
10^{-9}	2.0/1000 seconds	1000-3600 seconds

The duration value is set in seconds and can be set from 1 to 3,600 seconds (1 hour). This duration value indicates how long the alarm condition must last before an alarm will be declared. Low bit-error rates (10^7 through 10^9) are restricted to longer durations since it takes more than one second to detect an alarm condition above 10^6 . Higher bit-error rates are restricted to shorter durations because the MMI error counter fills at 65,000 errors.

The alarm indications (LEDs and external alarm contacts) will clear automatically after the specified period, or duration, has expired if the **Set Clearing (S C)** “Enable Self Clearing” option has been set. Otherwise, the alarm will continue until the command **Clear Alarm (C A)** has been entered.

- When an alarm is cleared, all activity caused by the alarm indications is cleared:
- the external alarm hardware is deactivated (the contact normally open will be reopened),
- the LED goes out,
- an entry is made in the alarm log of the date and time the alarm was cleared, and
- carrier-fail line supervision ceases (for alarm level 2 only).

If self-clearing alarm indications have been disabled, carrier-fail line supervision terminates when the alarm condition has ceased, but the external alarm contact and faceplate LED remain active until the alarm is cleared.

A heavy bit-error rate can cause 200 bit errors to occur much more quickly than 100 seconds. This causes the alarm to be declared sooner.

An alarm condition is not automatically cleared until the system no longer detects the respective bit error threshold during the corresponding duration period.

For example, if AL1 threshold of 6 (representing 10⁻⁶) is specified, and a duration period of 100 seconds is specified, an alarm is activated if more than 200 bit errors occur in any 100 second period. As soon as the alarm is activated, the bit counter is reset to 0. If the next 100 seconds pass, and less than 200 bit errors are detected, then the alarm clears after the alarm’s duration period. However, if more than 200 bit errors are detected in the next 100 seconds, the alarm condition continues for the designated time period.

The alarm finally clears when the alarm condition is no longer detected for the designated period, either by self-clearing (if this function is enabled), or when the **Clear Alarm (C A)** command is entered.

In addition to bit errors, the Set Alarm function sets parameters for detecting frame-slip errors by establishing a threshold necessary to activate an alarm. If the threshold value is exceeded, a level 2 alarm is activated. The frame slip threshold can be specified from 1 to 255 frame slips per time period. The duration time period can be specified from 1 to 24 hours.

When entering the **Set Alarm (S A)** command, the MMI scrolls through the previously described series of alarm options. These options are displayed along with their current value, at which point a new value can be entered or enter <CR> to retain the current value. Table 43 outlines the options available in the **Set Alarm (S A)** function.

Table 43
Set alarm options

Option	Description
AL1 Threshold	Sets the allowable bit errors per second before alarm level 1 is activated. Factory default is 6.
AL1 Duration	Sets the duration in seconds (from 1 to 3,600 seconds) that alarm level 1 is activated. Factory default is 10 seconds.
AL2 Threshold	Sets the allowable bit errors per second (from 3 to 9) before alarm level 2 is activated. Factory default is 10 ⁻⁵ .
AL2 Duration	Sets the duration in seconds (from 1 to 3,600 seconds) that alarm level 2 is activated. Factory default is 10 seconds.
Frame Slip Threshold	Sets the allowable frame slips per time period (from 1 to 255) before alarm level 2 is activated. Factory default is 5.
Frame Slip Duration	Sets the duration in hours (from 1 to 24) that the frame slips are counted. After this time period, the counter is reset to 0. Factory default is 2 hours.

Note: If the duration period set is too long, the Line-side E1 card is slow to return to service automatically even when the carrier is no longer experiencing errors. The **CLEAR ALARM (C A)** command has to be entered manually to restore service promptly. To avoid this, an alarm's duration period is normally set to 10 seconds.

Set Clearing

The **SET CLEARING (S C)** command allows self-clearing of alarms by responding to the question: **Enable Self Clearing? (YES or NO)**. If **YES** is chosen (the factory default setting), the system automatically clears (resets) alarms after the alarm condition is no longer detected. Choosing the **NO** option causes the system to continue the alarm condition until the **Clear Alarm (C A)** command is entered. Line processing and yellow alarm indication to the CPE terminates as soon as the alarm condition clears, even if self-clearing is disabled.

Set Simple

The **SET SIMPLE** command controls call tear-down signaling when the far-end disconnects from a call. Release 2 of the AB vintage introduces this feature.

When the far-end terminates a call, Release 1 of LEI's AB vintage sends a disconnect message to the terminal equipment and waits for the terminal equipment to go idle before going idle itself. A **NO** response to the **S S** command configures Release 2 (and later) boards to operate in this way. See Figure 32 on page 166.

Release 2 of AB vintage LEIs gives the administrator the option of using the signaling described above, or configuring the LEI to take its channel idle immediately after sending the call-disconnect message. A **YES** response to the **S S** command, the default configuration for Release 2 (and later) boards, configures the LEI to operate in this way. See Figure 33 on page 167.

Figure 32
Set Simple (S S) no screen

```
LEI::>S S
Enable Simplified Call Tear Down? (YES or NO)N
Simplified Call Tear Down Disabled.
LEI::>
```

Figure 33
Set Simple (S S) yes screen

```
LEI::>S S
Enable Simplified Call Tear Down? (YES or NO)Y
Simplified Call Tear Down Enabled.
LEI::>
```

Set Mode

At the **SET MODE (S M)** command, the MMI prompts the user with the current signaling mode, either Default (Australian P2) or Table (of bit values.) Entering a **<CR>** accepts the current value, or the user can type in 1 to revert to the Default, or 2 to edit the table entries. See Figure 34 on page 167. If the user selects default, then the A/B Bit values is reset to the Default values.

Figure 34
Set Mode (S M): <CR> screen

```
LEI:>S M
1) Default
2) Table
Hit <CR> to accept current value or type in a new one.
Current Mode : 1           New Mode :
Signaling Bits set to Default.

LEI:>
```

Responding to the MMI's **Set Mode** prompt with **"1"** also results in the line, **"Signaling Bits set to Default,"** as in Figure 34 on page 167.

However, responding to this prompt with **2** selects "Table" and allows the user to set the A/B Bit Mode to whatever configuration the user chooses.

If "Table" is selected, the individual table values will be prompted for. See Figures 35 on page 169 and Figure 36 on page 170. After each value is displayed, enter **<CR>** to do the following:

- accept the current value
- enter just the AB bits (which will be copied to the CD bits)

- enter a complete ABCD bit pattern
- in the case of optional states, a ‘N’ or ‘n’ can be entered to indicate that the state is not needed

Note that in D4 Framing for E1, there are no CD bits, so they will be ignored.

The user is prompted for ABCD bit values for the following states when the table mode is selected.

Send and Receive refer to the LEI sending ABCD bits to the CPE (Customer Provided Equipment) or receiving ABCD bits from the CPE.

Incoming and Outgoing refer to E1 digital link from the CPE point of view. Incoming is thus an external call arriving over the digital link and accepted by the CPE. Outgoing is a call originated by the CPE over the digital link.

Configuring the A/B Bit Signaling table is illustrated in Figures 35 on page 169 and Figure 36 on page 170.

Figure 35
Set Mode (S M): Table screen (Part One)

```
LEI:>S M
1) Default
2) Table
Hit <CR> to accept current value or type in a new one.
Current Mode : 1      New Mode : 2
Signaling Bits set to Table.

Incoming and outgoing calls are in reference to the CPE.
All ABCD bits are with respect to SENDING from LEI/M1 to CPE
or RECEIVING from CPE to LEI/M1.
Please enter new ABCD bits or hit <CR> to accept. You may
enter 2 or 4 values. If only 2 values are entered, the A and
B bits will be copied to the C and D bits.

IDLE SEND: Current: 0000 New: 0101
IDLE SEND bits changed to: 0101

IDLE RECEIVE: Current: 0101 New:
IDLE RECEIVE bits unchanged.

BLOCKING RECEIVE enabled? (Y/N): N
BLOCKING RECEIVE is disabled.

Incoming call RINGER-ON SEND: Current: 0000 New:
Incoming call RINGER-ON SEND bits not changed.

Incoming call RINGER-OFF SEND: Current: 0101 New: 0101
Incoming call RINGER-OFF SEND bits not changed.

Incoming call OFFHOOK RECEIVE: Current: 1111 New: 11
Incoming call OFFHOOK RECEIVE bits not changed.

Incoming call CONNECTED SEND: Current: 0101 New:
Incoming call CONNECTED SEND bits not changed.

Incoming call (Far End) DISCONNECT SEND: Current: 1111 New:
Incoming call (Far End) DISCONNECT SEND bits not changed.

Incoming call (CPE) DISCONNECT RECEIVE: Current: 0101 New:
Incoming call (CPE) DISCONNECT RECEIVE not changed.
```

Figure 36
Set Mode (S M): Table screen (Part Two)

```
Outgoing call SEIZE RECEIVE: Current: 0001 New: 111
Error: Note enough values specified. Enter either 2 or 4
values.
Outgoing call SEIZE RECEIVE: Current: 0001 New: 11
Outgoing call SEIZE RECEIVE bits changed to: 1111

Outgoing call SEIZE ACK SEND enabled? (Y/N): N
Outgoing call SEIZE ACK SEND is disabled.

Outgoing call DIAL MAKE RECEIVE: Current: 1111 New:
Outgoing call DIAL MAKE RECEIVE bits not changed.

Outgoing call DIAL BREAK RECEIVE: Current: 1010 New:
Outgoing call DIAL BREAK RECEIVE bits not changed.

Outgoing call ANSWERED SEND: Current: 0101 New:
Outgoing call ANSWERED SEND bits not changed.

Outgoing call (CPE) DISCONNECT RECEIVE: Current: 0101 New:
Outgoing call (CPE) DISCONNECT RECEIVE bits not changed.

Outgoing call (Far End) DISCONNECT SEND: Current: 1111 New:
Outgoing call (Far End) DISCONNECT SEND bits not changed.

Disconnect Time (0 to 4000 ms): 1000
Disconnect Time not changed.

Intercall Time (0 to 2000 ms): 800
Intercall Time not changed.

LEI:>
```

Idle SEND – This is the value that the LEI sends (acting as the CO or PSTN) when the circuit is in the idle state. This value is required.

Idle RECEIVE – This is the value that the LEI expects to see from the CPE when it is in the idle state. This value is required.

Blocking RECEIVE – This is the value that the LEI expects to see from the CPE when the customer equipment is in the blocking or fault state and is unable to accept new calls. Set this value to N if this state is not needed. If this value is not set to N, then dip switch #2 position 6 will determine whether off-hook or on-hook is sent to the M1/SL100 when this state is entered. See Table 36 on page 143.

Incoming call Ringer ON SEND – This is the value that the LEI sends to indicate that a call is incoming to the CPE and that ringing voltage should be applied at the CPE. This value is required.

Incoming call Ringer OFF SEND – This is the value that the LEI sends to indicate that a call is incoming to the CPE and that the ring cycle is in the off portion of the cadence. This value is required.

Incoming call Offhook RECEIVE – This is the value that the LEI expects to see from the CPE when the customer equipment has gone to an off hook state which indicates that the incoming call has been answered. This value is required.

Incoming call CONNECTED SEND – This is the value that the LEI sends to the CPE to indicate that it has seen and recognized the off hook indication sent by the CPE. The call is considered fully connected at this point. This value is required.

Incoming call (Far-end) DISCONNECT SEND – This is the value that the LEI sends to indicate that the far-end has released the call. This value is required.

Incoming call (CPE) DISCONNECT RECEIVE – This is the value that the LEI expects to see from the CPE when the customer equipment wishes to end the call. This value is required.

Outgoing call SEIZE RECEIVE – This is the value that the LEI expects to see when the CPE goes to an off hook condition and wishes to initiate a call. This value is required.

Outgoing call SEIZE ACK SEND – This is the value that the LEI will send to indicate that the seized condition has been noted and the M-1 is ready for dial digits. This value can be set to N if it is not required such as in a loop start case.

Outgoing call DIAL MAKE RECEIVE – This is the value that the LEI expects to see from the CPE during the make part of the digit. This value is required.

Outgoing call DIAL BREAK RECEIVE – This is the value that the LEI expects to see from the CPE during the break part of the digit. This value is required.

Outgoing call ANSWERED SEND – This is the value that the LEI will send to indicate that the far-end has answered the call. This value is required.

Outgoing call (CPE) DISCONNECT RECEIVE – This is the value that the LEI expects to see from the CPE when the customer equipment wishes to end the call. This value is required.

Outgoing call (Far-end) DISCONNECT SEND – This is the value that the LEI will send to indicate that the far-end has released the call. This value is required.

Disconnect Time – This is the number of milliseconds that the LEI will send the disconnect signal to the CPE before reverting to the idle state. If the CPE reverts to a connected state during this time, it is ignored. This value is only used when disconnect supervision is available and is needed for the signaling type in use. It is used when the far-end initiates the disconnect. For loop start cases, this value is not used.

Intercall (release guard) Time – This is the number of milliseconds that the LEI maintains the idle signal to the CPE before initiating a new call. The CPE should not initiate a new call during this time. If it does so, the off-hook indication is ignored until the release guard time has expired. This value defaults to 0 which relies on the M-1 to observe the proper guard time. If a non-zero value is entered, off-hook from the CPE and Ringer-On commands from the M1/SL100 is ignored until this timer has expired.

Display Configuration (D C)

The **Display Configuration (D C)** command displays the various configuration settings established for the LEI. Entering this command causes a screen similar to Figure 37 on page 173 to appear:

Figure 37
Display Configuration (D C) screen

```

LEI S/N 1103 Software Version 1.01 3/03/95 1:50
Alarms Enabled: YES Self Clearing Enabled: YES
Alarm Level 1 threshold value: E-7 Threshold duration (in
seconds): 10
Alarm Level 2 threshold value: E-5 Threshold duration (in
seconds): 1
Frame slips alarm level threshold: 5 Threshold duration (in hours):
2
Current dip switch S1 settings (S1..S8) On Off Off On Off Off Off On
Current dip switch S2 settings (S1..S8) On Off On Off Off Off On Off

```

Alarm operation and reporting

The MMI monitors the E1 link according to parameters established through the Set Alarm command for the following conditions:

- Excessive bit error rate
- Frame slip errors
- Out of frame condition
- Loss of signal condition
- Blue alarm (AIS) condition

Descriptions of the excessive bit error rate and frame slip errors conditions are found in “Configuring parameters” on page 161. Bit errors activate either a level 1 or level 2 alarm. The remaining conditions, when detected, always cause the system to activate a level 2 alarm.

An out-of-frame condition will be declared if 3 consecutive frame bits are in error. If this condition occurs, the hardware immediately attempts to reframe. During the reframe time, the E1 link is declared out-of-frame, and silence is sent on all receive timeslots.

A loss of signal condition is declared if a full frame (255 bits) of consecutive zeros has been detected at the receive inputs. If this condition occurs, the E1 link automatically attempts to resynchronize with the far-end. If this condition lasts for more than two seconds, a level 2 alarm is declared, and silence is sent on all receive timeslots. The alarm is cleared if, after two seconds, neither a loss of signal, out-of-frame condition, or blue alarm condition occurs.

If a repeating device loses signal, it immediately begins sending an unframed signal of all ones to the far-end to indicate an alarm condition. This condition is called a blue alarm, or an Alarm Indication Signal (AIS). If an AIS is detected for more than two seconds, a level 2 alarm is declared, and silence is sent on all receive timeslots. The alarm is cleared if, after two seconds, neither a loss of signal, out-of-frame condition, or blue alarm condition occurs.

Alarm Disable

The **Alarm Disable (A D)** command disables the external alarm contacts. When this command is typed, the MMI displays the message **Alarms Disabled** and the MAINT LED lights. In this mode, no yellow alarms are sent and the LEI does not enter line processing mode. Alarm messages are sent on the MMI terminal and the LED continues to indicate alarm conditions.

Alarm Enable

The **Alarm Enable (A E)** command does the reverse of the **Alarm Disable (A D)** command. It enables the external alarm contacts. When this command is typed in, the MMI will display the message **Alarms Enabled**. In this mode, yellow alarms can be sent and the LEI can enter line processing mode.

Clear Alarm

The **Clear Alarm (C A)** command clears all activity initiated by an alarm: the external alarm hardware is deactivated (the contact normally open is reopened), the LED goes out, an entry is made in the alarm log of the date and time the alarm was cleared, and line processing ceases (for alarm level 2 only). When this command is typed, MMI displays the message **Alarm acknowledged**. If the alarm condition still exists, an alarm is declared again.

Display Alarms

A detailed report of the most recent 100 alarms with time and date stamps can be displayed by entering the **Display Alarms (D A)** command into the MMI, which will cause a screen similar to Figure 38 on page 175 to appear.

Figure 38
Display Alarm (D A) screen

```
Alarm Log
2/03/99 1:48 Yellow alarm on E1 carrier
2/03/99 2:33 E1 carrier level 1 alarm
2/03/99 3:47 E1 carrier level 2 alarm
2/03/99 4:43 E1 carrier performance within thresholds
2/03/99 15:01 Log Cleared
```

The Pause command can be used to display a full screen at a time, by entering **D A P**. If there is more than one screen in the log, the MMI scrolls the log until the screen is full, then stops. When ready to see the next screen, press any key. The display shows another screen and stops again. This continues until the entire log has been displayed.

Clear Alarm Log

Clear all entries in the alarm log by typing the **Clear Alarm Log (C A L)** command.

Display Status

The **Display Status (D S)** command displays the current alarm condition of the E1 link as well as the on-hook or off-hook status of each of the 30 ports of the LEI. Entering this command causes a screen similar to Figure 39 on page 176 to appear.

The Pause command can be used to display a full screen at a time, by entering **D S P**. If there is more than one screen, the MMI scrolls until the screen is full, then stops. When ready to see the next screen, press any key. The display shows one more screen, and stops again. This continues until the entire E1 link has been reported on.

Figure 39
Display Status (D S) screen

```
LEI S/N Software Version 1.01 3/03/95 1:50
In alarm state: NO
E1 link at alarm level 0
Port 0 off hook, Port 1 on hook, Port 2 on hook, Port 3 on hook,
Port 4 on hook, Port 5 on hook, Port 6 off hook, Port 7 off hook,
Port 8 off hook, Port 9 on hook, Port 10 on hook, Port 11 on hook,
Port 12 off hook, Port 13 on hook, Port 14 on hook, Port 15 on hook,
Port 16 on hook, Port 17 on hook, Port 18 off hook, Port 19 off hook,
Port 20 off hook, Port 21 on hook, Port 22 on hook, Port 23 on hook
Port 21 off hook, Port 22 on hook, Port 23 on hook, Port 24 on hook,
Port 25 on hook, Port 26 on hook, Port 27 off hook, Port 28 off hook,
Port 29 off hook
```

Performance counters and reporting

The MMI monitors the performance of the E1 link according to several performance criteria including errored, bursty, unavailable, loss-of-frame and frame-slip seconds. It registers the performance of these criteria by reading their status every second and counting their results. These counts are accumulated for an hour, then reset to 0. Previous hour count results are maintained for each of the previous 24 hours.

The LEI counts CRC-4 errors when CRC-4 is enabled and Bipolar Violations (BPV) when CRC-4 is disabled. The performance criteria for which these counts are maintained as follows:

- Errored seconds are seconds in which one or more CRC-4 / BPV errors, or one or more out-of-frame errors in one second.
- Bursty seconds are seconds in which more than one and less than 320 CRC-4 / BPV errors in a second.
- Severely errored seconds are seconds in which more than 320 CRC-4 / BPV errors, or one or more out-of-frames in a second.
- Unavailable seconds are seconds in which unavailable state starts with 10 consecutive severely errored seconds and ends with 10 consecutive non-severely errored seconds (excluding the final 10 non-severely errored seconds).

- Loss-of-frame seconds are seconds in which loss-of-frame or loss-of-signal conditions have existed for three consecutive seconds.
- Frame slip seconds are seconds in which one or more frame slips occur.

The MMI also maintains an overall error counter which is the sum of all errors counted for the performance criteria listed above. The error counter can only be cleared by entering the **Clear Error (C E)** command. It stops counting at 65,000. The error counter provides an easy method to determine if an alarm condition has been corrected. Clear the error counter, wait a few minutes, and display the performance to see if any errors have occurred since the counter was cleared.

The MMI display reports on these performance counters through the **Display Performance (D P)** or the **Display History (D H)** commands.

Display Performance

Entering the **Display Performance (D P)** command displays performance counters for the past hour. A screen similar to Figure 40 will appear:

Figure 40
Display Performance (D P) screen

LEI E1 Interface Performance Log					
3/03/95 1:37 PM					
Data for the past 37 Minutes					
Errored Seconds	Bursty Seconds	Unavailable Seconds	Loss Frame Seconds	Frame Slip Seconds	Error Counter
2263	0	2263	2263	352	321

Each column, except the error counter, indicates the number of errors in the current hour and is reset to zero every hour on the hour. Just before the performance counters are reset to zero, the values are put into the history log.

The error counter indicates the number of errors since the error counter was cleared.

The Pause command can be used to display a full screen at a time, by entering **D P P**. If more than one screen is to be displayed, the MMI scrolls until the screen is full, then stops. When ready to see the next screen, press any key. The display shows one more screen, and stops again. This continues until the entire display has been shown.

Display History

Entering the **Display History (D H)** command displays performance counters for each hour of the past 24 in reverse chronological order, beginning with the last full hour. A screen similar to Figure 41 will appear.

The Pause command works the same for Display History as it does for the other display commands. Simply enter **D H P** to see a report on the performance counters, one screen at a time.

Figure 41
Display History (D H) screen

LEI E1 Interface History Performance Log						
1/03/99 8:37 PM						
Hour Ending	Errored Seconds	Bursty Seconds	Unavailable Seconds	Loss Frame Seconds	Frame Slip Seconds	Error Count
20:00	139	0	129	139	23	162
19:00	0	0	0	0	0	0
18:00	0	0	0	0	0	0
17:00	0	0	0	0	0	0
16:00	0	0	0	0	0	0

As with all **Display** commands, the Pause command can be used to display a full screen of the history report at a time, by entering **D H P**.

Clear Error

Reset the error counter to zero by entering the Clear Error (C E) command. The error counter provides a convenient way to determine if the E1 link is performing without errors since it can be cleared and examined at any time.

Testing

The **Test Carrier (T)** command allows tests to be run on the LEI, the E1 link, or the CPE device. The three tests are designed to provide the capability to isolate faulty conditions in any of these three sources. See Table 44 on page 180 for additional information on these three test types. Enter the **T** command, and at the prompt, enter which of these three tests is to be initiated. The prompt is similar to Figure 42:

Figure 42
Test Carrier (T) screen

```
Test 1: Local Loopback Test
Test 2: External Loopback Test
Test 3: Network Loopback Test
(1,2,3 or S to cancel):
```

Tests can be performed once, for one through 98 minutes, or continuously (selected by entering 99 minutes), until a **Stop Test** command is entered. Tests continue for the duration specified even if a failure occurs, and terminate at the end of the time period or when a **Stop Test** command is issued. Only **Stop Test** stops a test with a duration selection of 99; however, the **STOP** command terminates a test set to any duration from one to 99. After entering the test number, a prompt similar to Figure 43 appears.

Figure 43
Test parameters screen

```
Enter Duration of Test (1-98 Mins, 0 = Once, 99 = Forever)
Test will interfere with traffic. Hit Q to quit or any Key to Continue
```

Before a test is run, be sure to verify that the card is disabled, as the tests interfere with calls currently in process.

During a test, if an invalid word is received, this is recorded by a failure peg counter. The peg counter has a limit of 65,000. At the end of the test, the Test Results message indicates how many failures, if any, occurred during the test.

Table 44 on page 180 shows which test to run for the associated equipment:

Table 44
MMI Tests

Test number	Equipment Tested	Test Description
1	LEI	Local loopback
2	E1 link, LEI, and E1 network	External loopback
3	CPE device and E1 network	Network loopback

Test 1, local loopback, loops the E1 link signaling toward itself at the backplane connector. Test data is generated and received on all timeslots. If this test fails, it indicates that the LEI is defective. Figure 44 illustrates how the signaling is looped back toward itself.

Figure 44
MMI Local loopback test

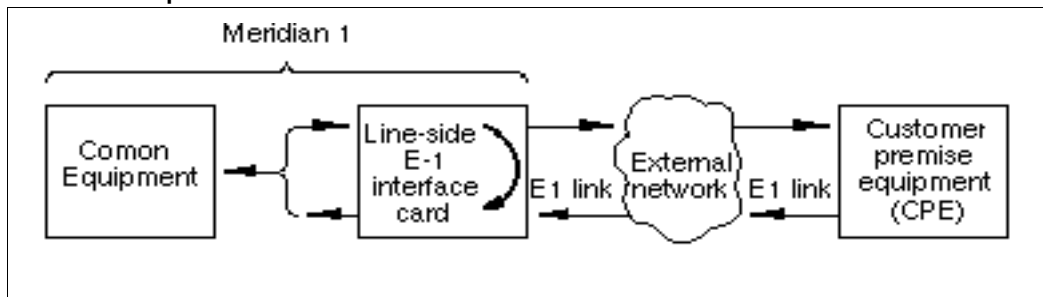

Test 2, external loopback, applies an external loopback to the E1 link. Test data is generated and received by the LEI on all timeslots. If test 1 passes but test 2 fails, it indicates that the E1 link is defective between the LEI and the external loopback location. If test 1 was not run and test 2 fails, the E1 link or the LEI could be defective. To isolate the failure to the E1 link, tests 1 and 2 must be run in tandem. Figure 45 on page 181 demonstrates how an external loopback is applied to the E1 link.

Figure 45
MMI External loopback test

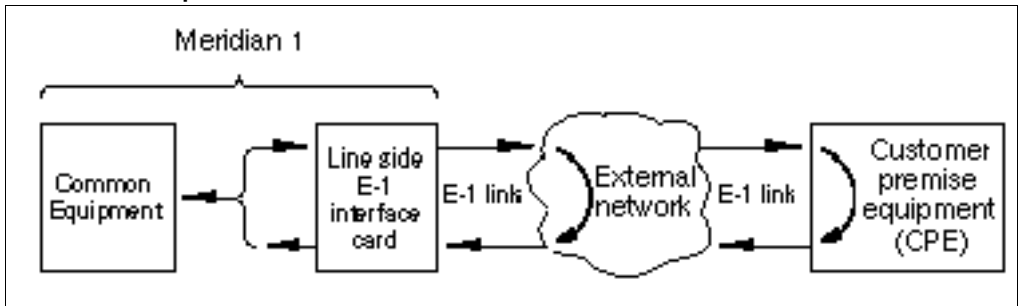

Test 3, network loopback, loops the LEI's received E1 data back toward the CPE. No test data is generated or received by the LEI. If test 2 passes but test 3 fails, it indicates that the CPE device is defective. If test 2 was not run and test 3 fails, the E1 link or the CPE device could be defective. To isolate the failure to the CPE device, tests 2 and 3 must be run in tandem. Figure 46 illustrates how the signaling is looped back toward the CPE.

Figure 46
MMI Network loopback test

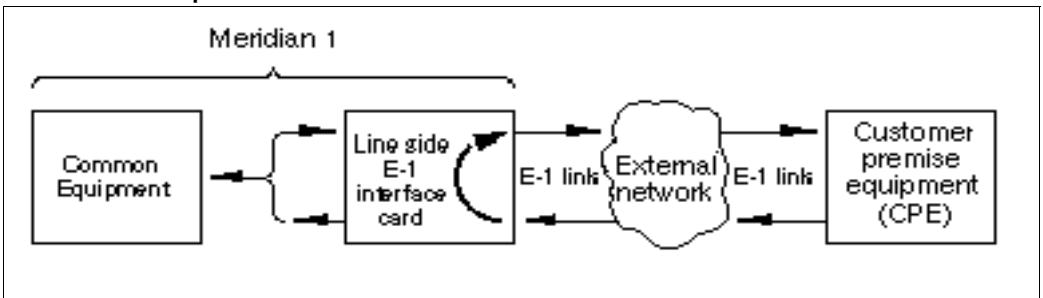

Applications

The LEI is an IPE line card that provides cost-effective connection between E1-compatible peripheral equipment and a Meridian 1 system or off-premise extensions over long distances.

Some examples of applications where an LEI can be interfaced to an E1 link are:

- E1-compatible VRU equipment
- E1-compatible turret systems
- E1-compatible wireless systems
- Remote analog (500/2500-type) telephones through E1 to channel bank
- Remote Norstar sites behind Meridian 1 over E1

The LEI is appropriate for any application where both E1 connectivity and “line-side” functionality are required. This includes connections to E1-compatible voice response units, voice messaging and trading turret (used in stock market applications) systems. See Figure 47.

Figure 47
LEI connection to peripheral equipment

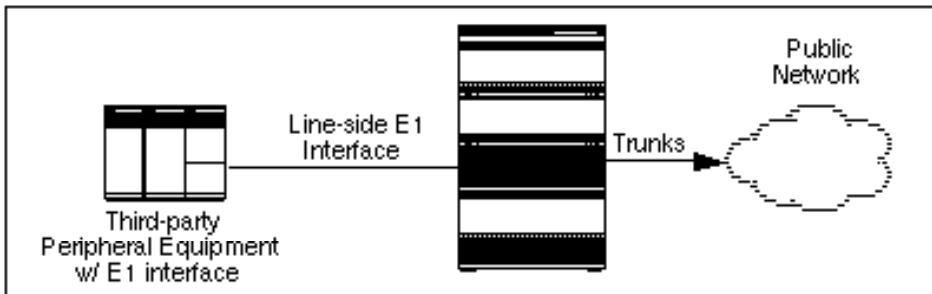

For example, the LEI can be used to connect the Meridian 1 to an E1-compatible Voice Response Unit (VRU). An example of this type of equipment is Nortel Networks Open IVR system. In this way, the Meridian 1 can send a call to the VRU, and, because the LEI supports analog (500/2500-type) telephone functionality, the VRU is able to send the call back to the Meridian 1 for further handling.

The LEI can also be used to provide off-premise extensions to remote locations, up to 500 miles from the Meridian 1 system. In this application, analog telephone functionality is extended over E1 facilities, providing a telephone at a remote site with access to analog (500/2500-type) telephone line functionality. See Figure 48. Audible Message Waiting Indicator can be provided as well.

Figure 48
LEI in off-premise extension application

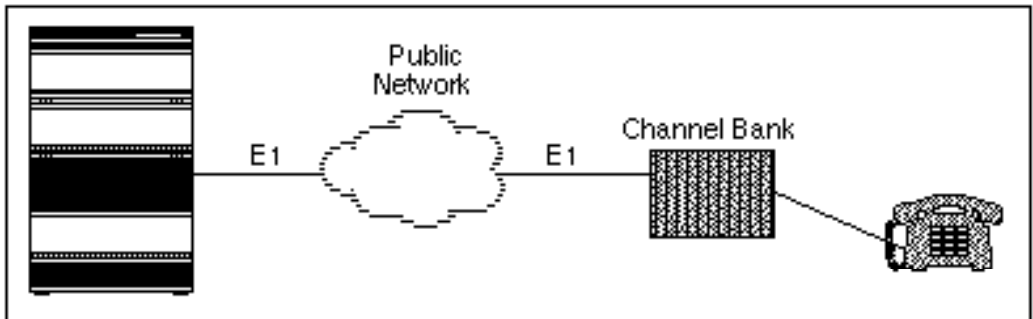

Similarly, use the LEI to provide a connection between the Meridian 1 and a remote Norstar system. See Figure 49 on page 184. In this case, channel banks are not required if the Norstar system is equipped with an E1 interface.

Note: Consider LEI audio levels when determining the appropriateness of an application.

Figure 49
LEI connection to Norstar system

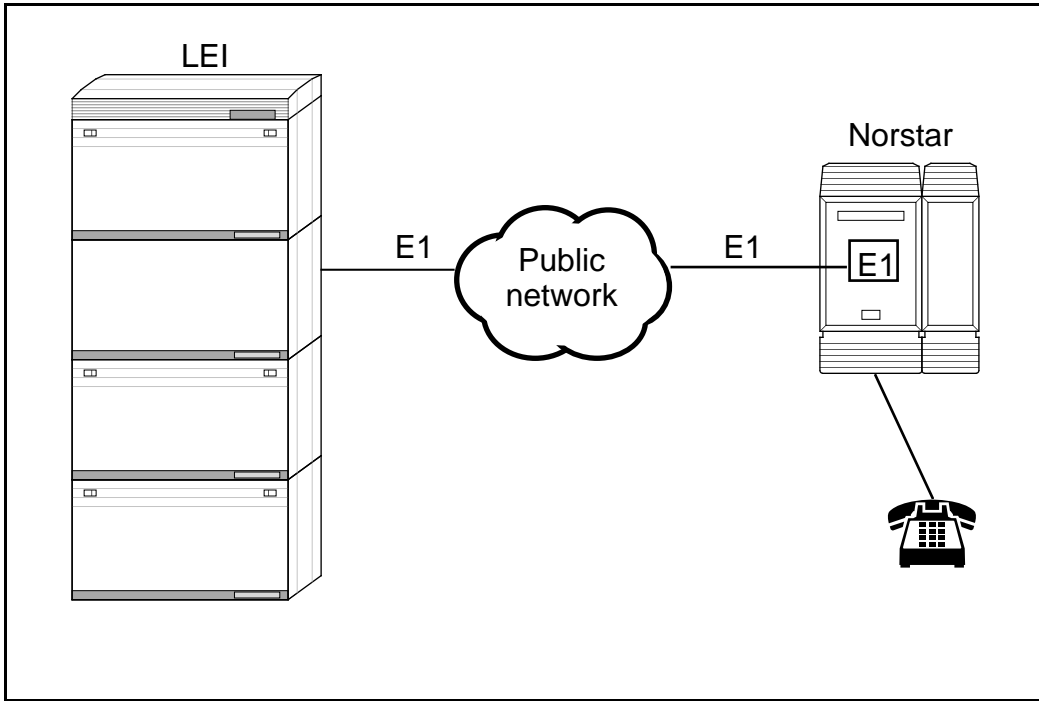

NT5D60AA CLASS Modem Card (XCMC)

Contents

This section contains information on the following topics:

Introduction	185
Physical description	186
Functional description	186
Electrical specifications	189
Data transmission specifications	189
Power requirements	189
Environmental specifications	189
Configuration	190
Software service changes	190

Reference list

The following are the references in this section:

- *Features and Services* (553-3001-306)
- *Software Input/Output Guide Administration* (553-3001-311)

Introduction

The NT5D60AA CLASS Modem card supports the Custom Local Area Signaling Services (CLASS) feature. The CLASS Modem card receives Calling Number and Calling Name Delivery (CND) data and time/date data from the system and transmits it to a line port, such as a port on an Analog Line card, which delivers the CND data to a CLASS telephone when presenting the telephone with a new call.

For information about the CLASS: Calling Number and Name Delivery feature, please refer to the *Features and Services* (553-3001-306). For administration and maintenance commands, see the *Software Input/Output Guide Administration* (553-3001-311).

Physical description

CLASS Modem cards are housed in NT8D37 Intelligent Peripheral Equipment (IPE) Modules.

The CLASS modem card circuitry is mounted on a 31.75 cm by 25.40 cm (12.5 in. by 10 in.) double-sided printed circuit board. The card connects to the backplane through a 160-pin edge connector.

The faceplate of the CLASS modem card is equipped with a red LED that lights when the card is disabled. When the card is installed, the LED remains lit for two to five seconds as a self-test runs. If the self-test completes successfully, the LED flashes three times and remains lit until the card is configured and enabled in software, then the LED goes out. If the LED continually flashes or remains weakly lit, replace the card.

Functional description

The CLASS Modem card is designed to plug into any one of the peripheral card slots of the IPE module. The CLASS modem card supports up to 32 transmit-only modem resources, using a DS30X interface. Up to 255 modems can be configured per system.

The CND transmission process begins with the system software sending an initiating message to the CLASS Modem card indicating the length of the CND information and the type of the CND information flow to be transmitted. In response, the CLASS Modem card assigns a message buffer to capture the CND information from the system software.

System software then sends the CND information to the CLASS Modem card, one byte at a time, where it is stored in the message buffer. If the CLASS Modem card receives more bytes than were specified in the initiating message, then the additional bytes will be discarded and will not be included in the CND memory buffer.

Once all of the CND information has been stored in the memory buffer, the CLASS Modem card begins transmission when requested by the system software. Data is sent one ASCII character at a time. The CLASS Modem card inserts a start and stop bit to each ASCII character sent.

The transmission of the calling party name/number to the terminating telephone is accomplished through asynchronous FSK simplex-mode transmission at 1200 bits/second over a 2-wire loop, in accordance with the Bell 202 standard. The transmission is implemented by the appropriate PCM equivalent of 1200 or 2200 Hz.

Upon completion of transmitting the CND data, the CLASS Modem card sends a message to the system software to indicate successful transmission of the CND data.

Eight modems can be associated with each module. Table 45 shows time slot mapping for the CLASS modem card.

Table 45
Time slot mapping (Part 1 of 2)

XCMC mapping of TNs		Modem units on the CLASS Modem card
TNs	DS30X timeslot	
00	00	module 0, 00 01 02 03
01	01	
02	02	
03	03	
04	04	04 05 06 07
05	05	
06	06	
07	07	

Table 45
Time slot mapping (Part 2 of 2)

XCMC mapping of TNs		Modem units on the CLASS Modem card
TNs	DS30X timeslot	
08	08	module 1, 00 01 02 03
09	09	
10	10	
11	11	
12	12	04 05 06 07
13	13	
14	14	
15	15	
16	16	module 2, 00 01 02 03
17	17	
18	18	
19	19	
20	20	04 05 06 07
21	21	
22	22	
23	23	
24	24	module 3, 00 01 02 03
25	25	
26	26	
27	27	
28	28	04 05 06 07
29	29	
30	30	
31	31	

Electrical specifications

This section lists the electrical characteristic of the CLASS modem card.

Data transmission specifications

Table 46 provides specifications for the 32 transmit-only modem resources.

Table 46
CLASS modem card—data transmission electrical characteristics

Characteristics	Description
Units per card	32 transmit only modem resources
Transmission rate	1200 ± 12 baud

The CLASS modem card has no direct connection to the Public Network.

Power requirements

The CLASS modem card requires less than 1.0 Amps of +5V dc ± 1% supply supplied by the power converter in the IPE shelf.

Environmental specifications

Table 47 shows the environmental specifications of the card.

Table 47
CLASS modem card – environmental specifications

Parameter	Specifications
Operating temperature	0° C to +65° C (+32 ° F to +149 ° F)
Operating humidity	5 to 95% RH (non-condensing)
Storage temperature	-50° C to +70° C (-58 ° F to +158 ° F)

Configuration

The NT5D60AA CLASS Modem card has no user-configurable jumpers or switches. The card derives its address from its position in the backplane and reports that information back to the Meridian 1 CPU through the Cardlan interface.

Software service changes

On systems which are equipped with either CNUMB (package 332) or CNAME (package 333), up to 255 CLASS Modem (CMOD) units can be configured in LD 13, and analog (500/2500-type) telephones can be assigned as CLASS telephones in LD 10 by assigning them CNUS, or CNUA and CNAA class of service. See the *Software Input/Output Guide Administration* (553-3001-311) for LD 10 and LD 13 service change instructions.

NT8D02 Digital Line Card

Contents

This section contains information on the following topics:

Introduction	192
Physical description	192
Functional description	194
Card interfaces	196
Digital line interfaces	196
Card control functions	197
Circuit power	198
Electrical specifications	199
Digital line interface specifications	199
Power requirements	200
Foreign and surge voltage protections	200
Environmental specifications	201
Connector pin assignments	201
Configuration	203
Jumper and switch settings	203
Software service changes	203

Reference list

The following are the references in this section:

- *System Installation Procedures (553-3001-210)*
- *Software Input/Output Guide Administration (553-3001-311)*

Introduction

The NT8D02 Digital Line Card is an intelligent peripheral equipment (IPE) device that can be installed in the NT8D37 IPE Module. It provides 16 voice and 16 data communication links between a Meridian 1 switch and modular digital telephones.

The digital line card supports voice only or simultaneous voice and data service over a single twisted pair of standard telephone wiring. When a digital telephone is equipped with the data option, an asynchronous ASCII terminal, or a PC acting as an asynchronous ASCII terminal, can be connected to the system through the digital telephone.

Physical description

Digital line cards are housed in NT8D37 Intelligent Peripheral Equipment (IPE) Modules. Up to 16 cards are supported.

The digital line card circuitry is mounted on a 31.75 cm by 25.40 cm (12.5 in. by 10 in.) double-sided printed circuit board. The card connects to the backplane through a 160-pin edge connector.

The faceplate of the digital line card is equipped with a red LED that lights when the card is disabled. See Figure 50 on page 193. When the card is installed, the LED remains lit for two to five seconds as a self-test runs. If the self-test completes successfully, the LED flashes three times and remains lit until the card is configured and enabled in software, then the LED goes out. If the LED continually flashes or remains weakly lit, replace the card.

Figure 50
Digital line card – faceplate

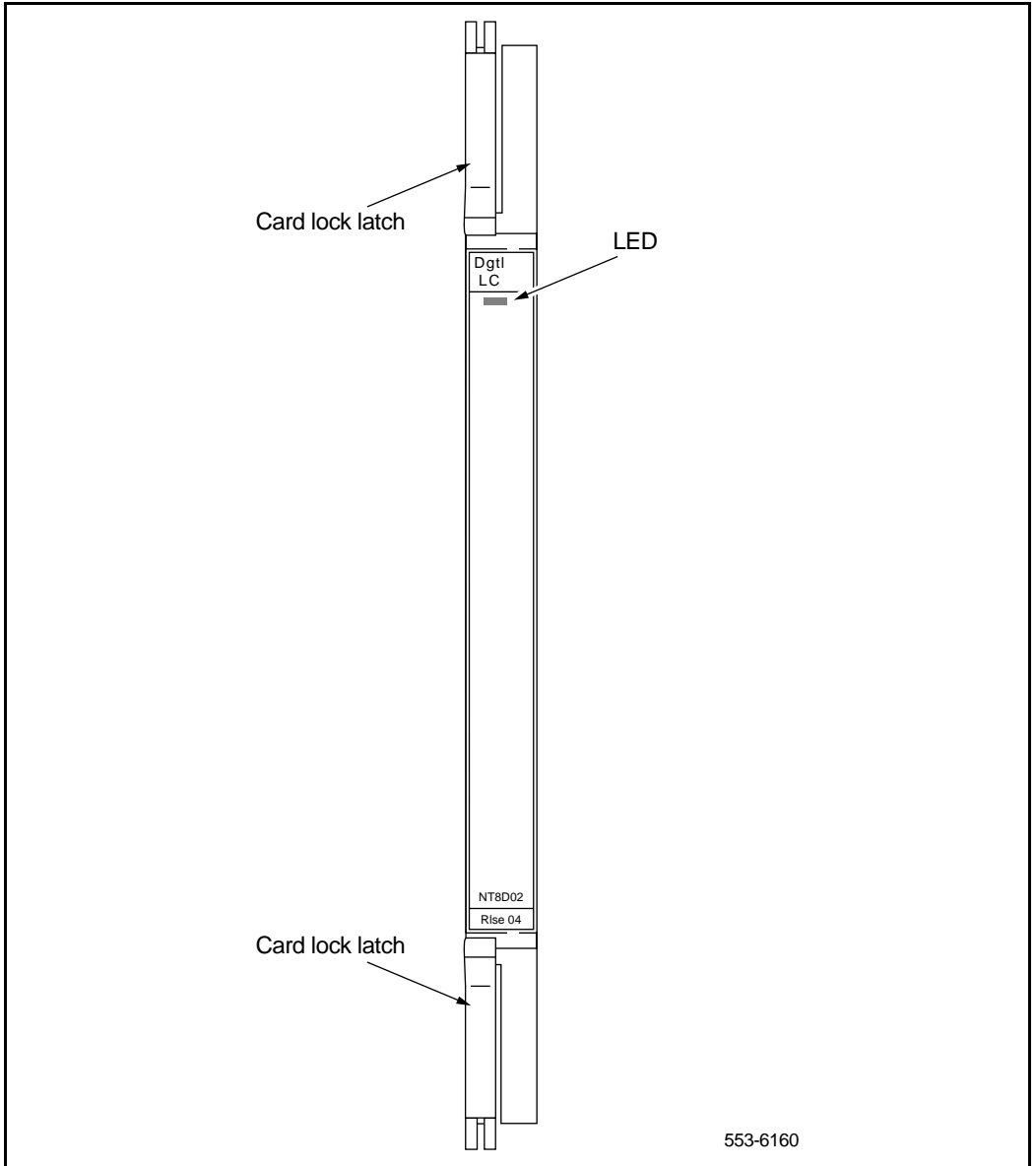

Functional description

The digital line card is equipped with 16 identical digital line interfaces. Each interface provides a multiplexed voice, data, and signaling path to and from a digital terminal (telephone) over a 2-wire full duplex 512 kHz Time Compression Multiplexed (TCM) digital link. Each digital telephone and associated data terminal is assigned a separate Terminal Number (TN) in the system database, giving a total of 32 addressable units per card. The digital line card supports Nortel Networks' Meridian Digital Telephone.

Figure 51 on page 195 shows a block diagram of the major functions contained on the digital line card. Each of these functions are described on the following pages.

Figure 51
Digital line card – block diagram

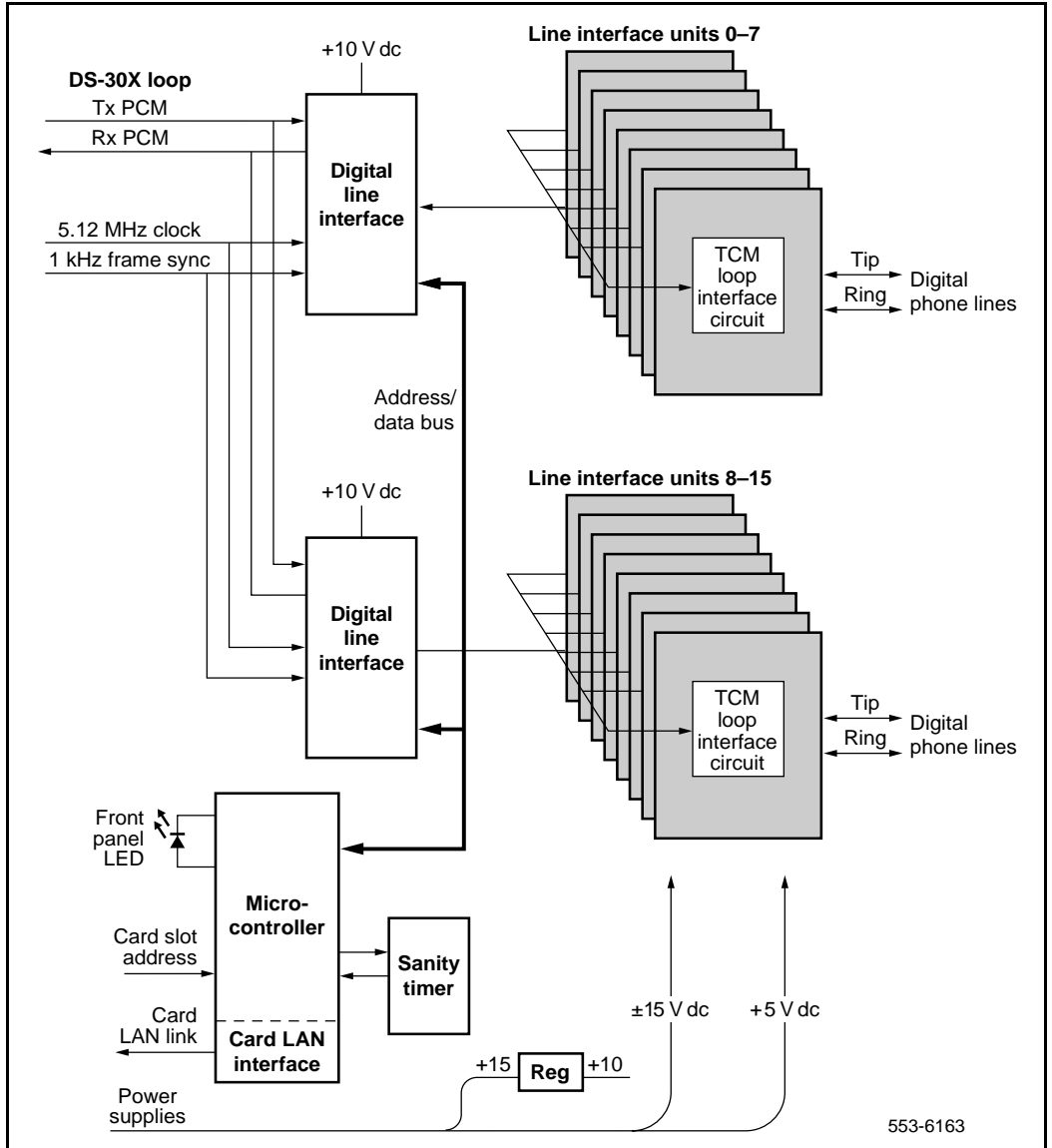

Card interfaces

The digital line card passes voice, data, and signaling over DS-30X loops and maintenance data over the card LAN link. These interfaces are discussed in detail in the section “Intelligent peripheral equipment” on page 19.

Digital line interfaces

The digital line interface contains two Digital Line Interface Circuits (DLIC). Each digital line interface circuit provides eight identical, individually configurable voice and data interfaces to eight digital telephone lines. These lines carry multiplexed PCM voice, data, and signaling information as TCM loops. Each TCM loop can be connected to a Nortel Networks M2xxx, M39xx, or Aries digital telephone.

The purpose of each digital line interface circuit is to demultiplex data from the DS-30X Tx channel into eight integrated voice and data bitstreams and transmit those bitstreams as Bi-Polar Return to Zero, Alternate Mark Inversion (BPRZ-AMI) data to the eight TCM loops. They also do the opposite: receive eight BPRZ-AMI bitstreams from the TCM loops and multiplex them onto the DS-30X Rx channel. The two digital line interface circuits together perform the multiplexing and demultiplexing functions for the 16 digital telephone lines.

The digital line interface circuits also contain signaling and control circuits that establish, supervise, and take down call connections. These circuits work with the on-card microcontroller to operate the digital line interface circuits during calls. The circuits receive outgoing call signaling messages from the CP and return incoming call status information to the CP over the DS-30X network loop.

TCM loop interface circuit

Each digital telephone line terminates on the digital line card at a TCM loop interface circuit. The circuit provides transformer coupling and foreign voltage protection between the TCM loop and the digital line interface circuit. It also provides battery voltage for the digital telephone.

To prevent undesirable side effects from occurring when the TCM loop interface cannot provide the proper signals on the digital phone line, the card microcontroller can remove the ± 15 V dc power supply from the TCM loop interfaces. This happens when either the microcontroller gets a command from the NT8D01 controller card to shut down the channel or the digital line card detects a loss of the 1 KHz frame synchronization signal. The ± 15 V dc power supply signal is removed from all 16 TCM loop interface units at the same time.

Each TCM loop interface circuit can service loops up to 3500 ft. in length when using 24-gauge wire. They allow for a maximum AC signal loss of 15.5 dB at 256 KHz and a maximum DC loop resistance of 210 ohms.

Card control functions

Control functions are provided by a microcontroller and a Card LAN link on the digital line card. A sanity timer is provided to automatically reset the card if the microcontroller stops functioning for any reason.

Microcontroller

The digital line card contains a microcontroller that controls the internal operation of the card and the serial card LAN link to the controller card. The microcontroller controls the following:

- reporting to the CE CP through the card LAN link:
 - card identification (card type, vintage, and serial number)
 - firmware version
 - self-test status
 - programmed configuration status
- receipt and implementation of card configuration:
 - programming of the digital line interfaces
 - enabling/disabling of individual units or entire card
 - programming of loop interface control circuits for administration of line interface unit operation
 - maintenance diagnostics

The microcontroller also controls the front panel LED when the card is enabled or disabled by instructions from the NT8D01 controller card.

Card LAN interface

Maintenance data is exchanged with the common equipment CP over a dedicated asynchronous serial network called the Card LAN link. The Card LAN link is described in the section “Intelligent peripheral equipment” on page 19.

Sanity timer

The digital line card also contains a sanity timer that resets the microcontroller if program control is lost. The microcontroller must service the sanity timer every 1.2 seconds. If the timer is not properly serviced, it times out and causes the microcontroller to be hardware reset.

Circuit power

The +15 V dc input is regulated down to +10 V dc for use by the digital line interface circuits. The ± 15.0 V dc inputs to the card are used to power the loop interface circuits.

Electrical specifications

This section lists the electrical characteristic of the digital line card.

Digital line interface specifications

Table 48 provides specifications for the 16 digital line interfaces, and Table 49 lists the maximum power consumed by the card.

Table 48
Digital line card – line interface unit electrical characteristics

Characteristics	Description
Units per card	16 voice, 16 data
Line rate	512 kbps \pm 100 ppm
Impedance	100 Ω
Loop limits	0 to 1067 m (3500 ft.) with 24 AWG PVC cable (\pm 15 V dc at 80 mA)
Maximum ac Signal loss	15.5 dB at 256 KHz
Maximum dc Loop resistance	210 ohms
Transmitter output voltage:	
• successive "1" bits	+1.5 \pm 0.15 V and -1.5 \pm 0.15 V
• "0" bits	0 \pm 50 mV

Power requirements

The digital line card provides +15 V dc over each loop at a maximum current of 80 mA. It requires +15 V, -15 V, and +5 V from the backplane. One NT8D06 Peripheral Equipment Power Supply ac or NT6D40 Peripheral Equipment Power Supply dc can supply power to a maximum of 16 digital line cards.

Table 49
Digital line card—power required

Voltage	Current (max.)
±5.0 V dc	150 mA
+15.0 V dc	1.6 Amp
-15.0 V dc	1.3 Amp

Foreign and surge voltage protections

In-circuit protection against power line crosses or lightning is not provided on the digital line card. The digital line card does, however, have protection against accidental shorts to -52 V dc analog lines.

When the card is used to service off-premise telephones, primary and secondary Main Distribution Frame (MDF) protection must be installed. Details on installing protection devices are given in “Off-premise line protection” on page 42.

Off-premise telephones served by cable pairs routed through the central office, or crossing a public right-of-way, can be subject to a requirement for on-card protection, and MDF protectors may not be acceptable. Check local regulations before providing such service.

Environmental specifications

Table 50 shows the environmental specifications of the card.

Table 50
Digital line card – environmental specifications

Parameter	Specifications
Operating temperature	0° to +60° C (+32 to +140° F), ambient
Operating humidity	5 to 95% RH (non-condensing)
Storage temperature	–40° to +70° C (–40° to +158° F)

Connector pin assignments

Table 51 on page 202 shows the I/O pin designations at the backplane connector, which is arranged as an 80-row by 2-column array of pins. Normally, these pin positions are cabled to 50-pin connectors at the I/O panel in the rear of each module for connection with 25-pair cables to the MDF.

The information in Table 51 is provided as a reference and diagnostic aid at the backplane, since the cabling arrangement may vary at the I/O panel. See *System Installation Procedures* (553-3001-210) for cable pinout information for the I/O panel.

Table 51
Digital line card – backplane pinouts

Backplane Pinout*	Lead Designations	Backplane Pinout*	Lead Designations
12A	Line 0, Ring	12B	Line 0, Tip
13A	Line 1, Ring	13B	Line 1, Tip
14A	Line 2, Ring	14B	Line 2, Tip
15A	Line 3, Ring	15B	Line 3, Tip
16A	Line 4, Ring	16B	Line 4, Tip
17A	Line 5, Ring	17B	Line 5, Tip
18A	Line 6, Ring	18B	Line 6, Tip
19A	Line 7, Ring	19B	Line 7, Tip
62A	Line 8, Ring	62B	Line 8, Tip
63A	Line 9, Ring	63B	Line 9, Tip
64A	Line 10, Ring	64B	Line 10, Tip
65A	Line 11, Ring	65B	Line 11, Tip
66A	Line 12, Ring	66B	Line 12, Tip
67A	Line 13, Ring	67B	Line 13, Tip
68A	Line 14, Ring	68B	Line 14, Tip
69A	Line 15, Ring	69B	Line 15, Tip
* These pinouts apply to both the NT8D37 and NT8D11 backplanes			

Configuration

This section outlines the procedures for configuring the switches and jumpers on the NT8D02 Digital Line Card and configuring the system software to properly recognize the card. Figure 52 on page 204 shows where the switches and jumper blocks are located on this board.

Jumper and switch settings

The NT8D02 Digital Line Card has no user-configurable jumpers or switches. The card derives its address from its position in the backplane and reports that information back to the Meridian 1 CP through the LAN Link interface.

Software service changes

Voice and data ports are configured using the Meridian Digital Telephone Administration program LD 11. See the *Software Input/Output Guide Administration* (553-3001-311) for LD 11 service change instructions.

Figure 52
Digital line card – jumper block and switch locations.

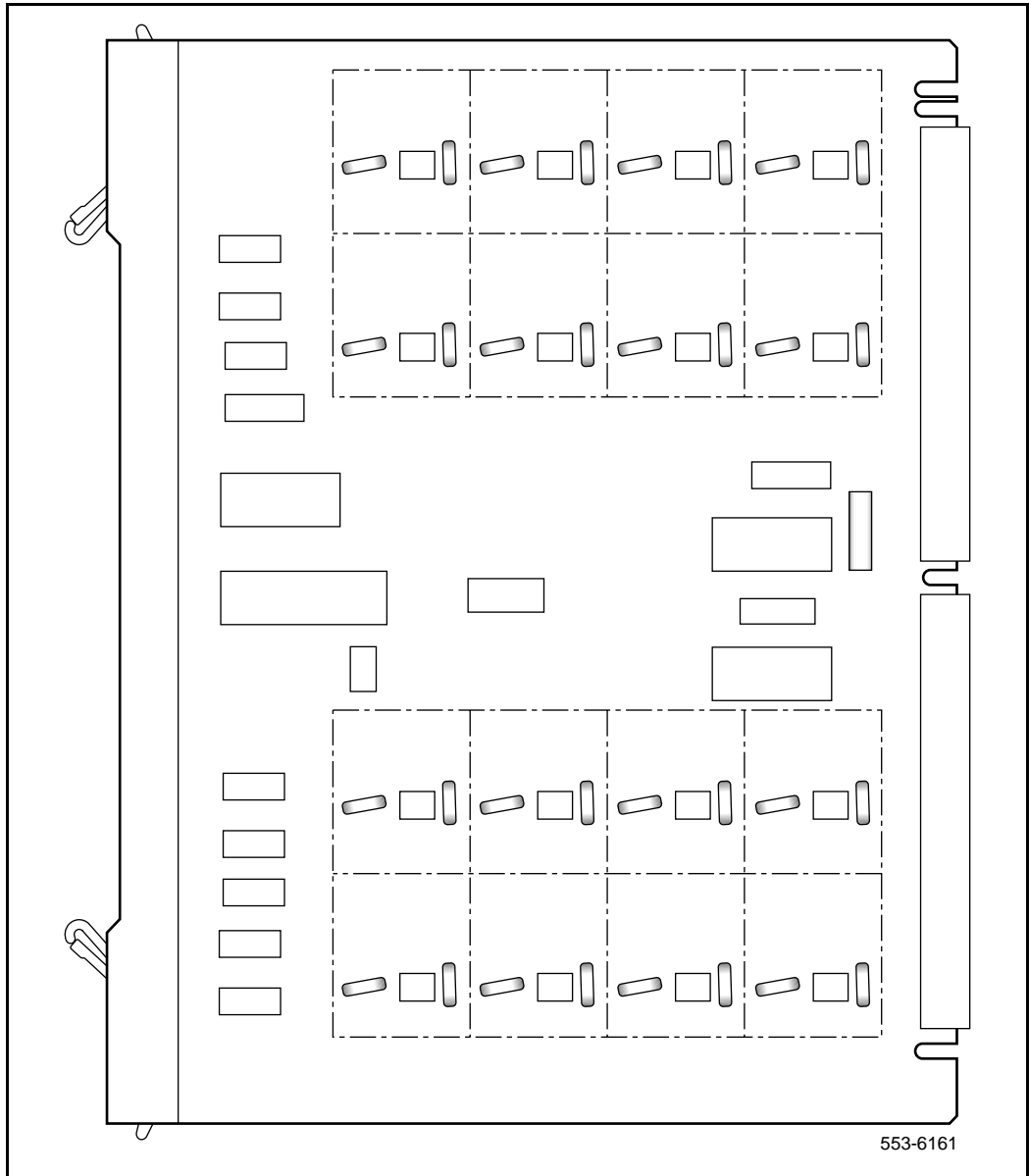

NT8D09 Analog Message Waiting Line Card

Contents

This section contains information on the following topics:

Introduction	206
Physical description	207
Functional description	209
Card interfaces	209
Line interface units	209
Card control functions	211
Circuit power	212
Electrical specifications	213
Analog line interface	213
Power requirements	215
Foreign and surge voltage protections	216
Environmental specifications	216
Connector pin assignments	216
Configuration	218
Jumper and switch settings	219
Software service changes	219

Reference list

The following are the references in this section:

- *System Installation Procedures (553-3001-210)*
- *Software Input/Output Guide Administration (553-3001-311)*

Introduction

The NT8D09 Analog Message Waiting Line Card is an Intelligent Peripheral Equipment (IPE) line card that can be installed in the NT8D37 IPE module. Up to 16 cards are supported.

The analog message waiting line card provides talk battery and signaling for up to 16 regular 2-wire common battery analog (500/2500-type) telephones and key telephone equipment. The card can also connect a high-voltage, low-current feed to each line to light the message waiting lamp on telephones equipped with the Message Waiting feature. This voltage is provided by the NT6D40 Peripheral Equipment Power Supply, DC.

Cards later than vintage NT8D09AK support μ -Law and A-Law companding, and provide a 2 dB transmission profile change. The transmission change improves performance on long lines, particularly for lines used outside of a single-building environment.



CAUTION **Damage to Equipment**

If a modem is connected to a port on the message waiting line card, that port should not be defined in software (LD 10) as having message waiting capabilities. Otherwise, the modem will be damaged.

Physical description

The analog message waiting line card mounts in any IPE slot. The circuitry is mounted on a 31.75 cm. by 25.40 cm (12.5 in. by 10 in.) printed circuit board.

The analog message waiting line card connects to the backplane through a 160-pin edge connector. The backplane is cabled to the Input/Output (I/O) panel that then connects to the Main Distribution Frame (MDF), also called a cross-connect terminal through 25-pair cables. Telephones connect to the card through the MDF. See *System Installation Procedures* (553-3001-210) for termination and cross-connect information.

The faceplate of the analog message waiting line card is equipped with a red LED that lights when the card is disabled. See Figure 53 on page 208. When the card is installed, the LED remains lit for two to five seconds as a self-test runs. If the self-test completes successfully, the LED flashes three times and remains lit until the card is configured and enabled in software; then the LED goes out. If the LED continually flashes or remains weakly lit, the card should be replaced. .

Figure 53
Analog message waiting line card – faceplate

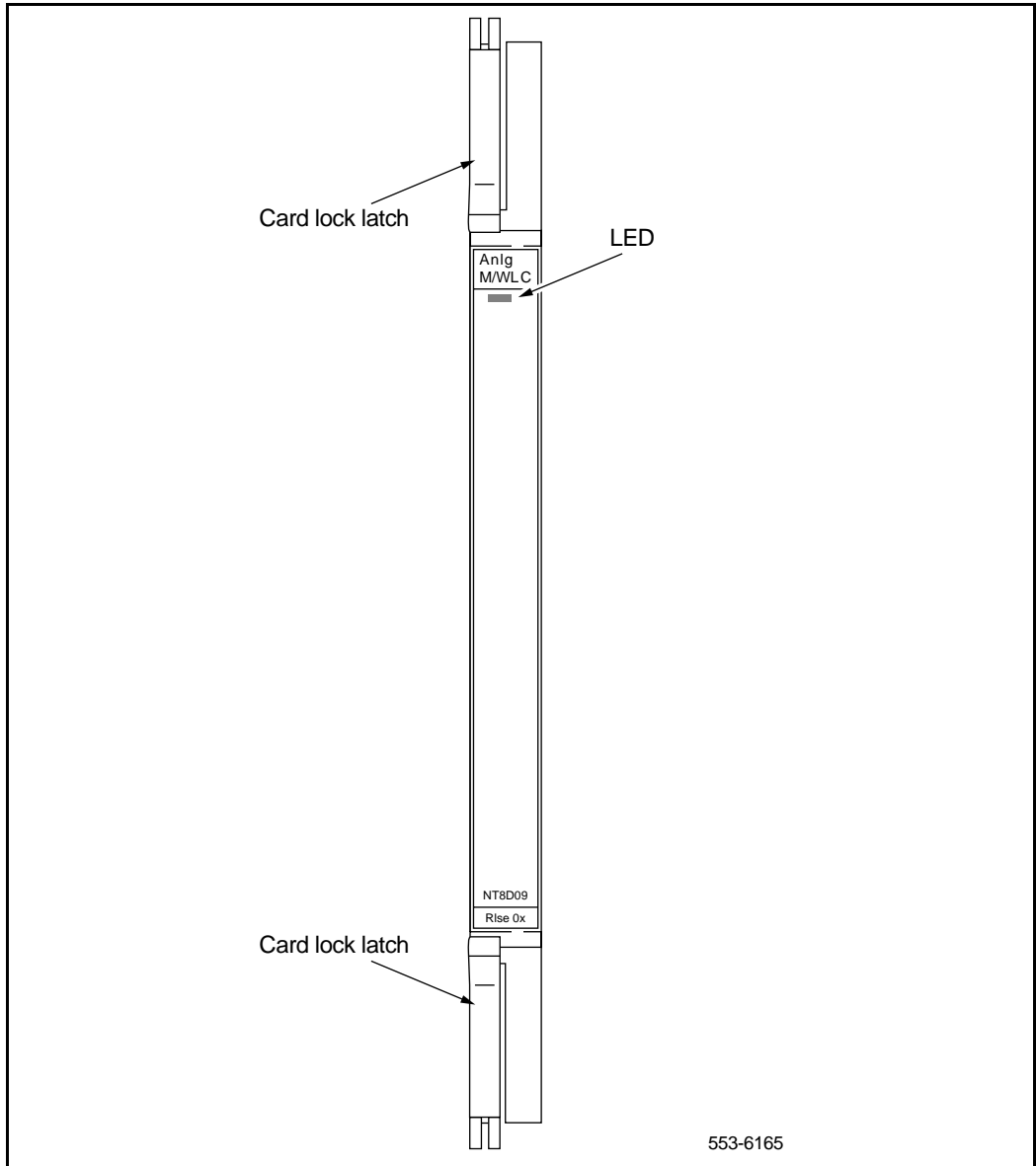

Functional description

Figure 54 on page 210 shows a block diagram of the major functions contained on the analog message waiting line card. Each of these functions are described in the following sections.

Card interfaces

The analog message waiting line card passes voice and signaling data over DS-30X loops and maintenance data over the card LAN link. These interfaces are discussed in “Intelligent peripheral equipment” on page 19.

Line interface units

The analog message waiting line card contains 16 identical and independently configurable line interface units (also referred to as circuits). Each unit provides 600-ohm impedance matching and a balance network in a signal transformer/analog hybrid circuit. Circuits are also provided in each unit to apply the ringing voltage onto the line synchronized to the ringing current zero crossing. Signal detection circuits monitor on-hook/off-hook status and switchhook flash detection. Four CODECs are provided to perform A/D and D/A conversion of line analog voiceband signals to digital PCM signals. Each CODEC supports four line interface units. The following features are common to all units on the card:

- transmission and reception of Scan and Signaling Device (SSD) signaling messages over a DS30X signaling channel in A10 format
- loopback of SSD messages and pulse code modulation (PCM) signals for diagnostic purposes
- correct initialization of all features, as configured in software, at power-up
- direct reporting of digits dialed (500 telephones) by collecting dial pulses
- connection of -150 V dc at 1 Hz to activate message waiting lamps in two telephones in parallel. The two telephones must be the same type or the neon series resistor in each telephone must be 54 K ohms or greater.
- lamp status detection (will not detect a failure of either lamp when operating in parallel)
- disabling and enabling of selected units for maintenance
- 40 mA to telephones with short circuit protection

Card control functions

Control functions are provided by the following:

- a microcontroller
- a card LAN interface
- signaling and control circuits on the analog message waiting line card

Microcontroller

The analog message waiting line card contains a microcontroller that controls the internal operation of the card and the serial card LAN link to the controller card. The microcontroller controls the following:

- reporting to the CE CP through the card LAN link:
 - card identification (card type, vintage, and serial number)
 - firmware version
 - self-test status
 - programmed configuration status
- receipt and implementation of card configuration:
 - programming of the CODECs
 - enabling/disabling of individual units or entire card
 - programming of input/output interface control circuits for administration of line interface unit operation
 - enabling/disabling of an interrupted dial tone to indicate call waiting
 - maintenance diagnostics
 - transmission loss levels

Signaling and control

The signaling and control portion of the card provides circuits that establish, supervise, and take down call connections. These circuits work with the system CP to operate the line interface circuits during calls. The circuits receive outgoing call signaling messages from the CP and return incoming call status information over the DS-30X network loop.

Circuit power

The +8.5 V dc input is regulated down to +5 V dc for use by the digital logic circuits. All other power to the card is used by the line interface circuits. The +15.0 V dc input is regulated down to +12 V dc to power the analog circuits. The -48.0 V dc input is for the telephone battery.

Ring power for telephones is 86 Vrms ac at 20 Hz on -48 V dc. The Rsync signal is used to switch 20 Hz ringing on and off at the zero current cross-over point to lengthen the life of the switching circuits.

Power for lighting the message waiting lights is provided by either the peripheral equipment power supply or the ringing generator. Logic on the message waiting line card interrupts the -150 V dc signal at 1 Hz intervals to provide a flashing message waiting light.

Electrical specifications

This section lists the electrical characteristics of the analog message waiting line card.

Analog line interface

The NT8D09 Analog Message Waiting Line Card meets the EIA/TA464 standard for ONS Type II line cards. Table 52 shows a summary of the analog line interface unit electrical characteristics.

Table 52
Analog message waiting line card – line interface unit electrical characteristics

Characteristics	Description
Impedance	600 ohms
Loop limit (excluding telephone)	1000 ohms at nominal –48 V (excluding telephone)
Leakage resistance	30,000 ohms
Ring trip	During silent or ringing intervals
Ringing voltage	86 V ac
Signaling	Loop start
Supervision	Normal battery conditions are continuously applied (approximately –44.5 V on ring and –2.5 V on tip at nominal –48 V battery)
Power input from backplane	–48 (can be as low as –42 for DC-powered systems), +15, +8.5, –150 V and ringing voltage
Insertion loss	4 dB \pm 1 dB at 1020 Hz 3.5 dB loss for analog to PCM 0.5 dB loss for PCM to analog

Input impedance

The impedance at tip and ring is 600 ohms with a return loss of

- 20 dB for 200-500 Hz
- 26 dB for 500-3400 Hz

Frequency response

The loss values in Table 53 are measured relative to the loss at 1 kHz.

Table 53
Analog message waiting line card – frequency response

Frequency (Hz)	Minimum (dB)	Maximum (dB)
60	20.0	—
200	0.0	5.0
300	-0.5	1.0
3000	-0.5	1.0
3200	-0.5	1.5
3400	0.0	3.0

Message channel noise

The message channel noise C-weighted (dBmC) on 95 percent of the connections (line to line) with both ends terminated in 600 ohms does not exceed 20 dBmC.

Overload level

Signal levels exceeding +6.5 dBm applied to the tip and ring cause distortion in speech transmission.

Power requirements

Table 54 provides the power requirements for the analog message waiting line card.

Table 54
Analog message waiting line card – power requirements

Voltage (+/-)	Tolerance	Idle current	Active current	Maximum
+12.0 V dc	0.36 V dc	48 mA	0 mA	48 mA
+8.5 V dc	0.40 V dc	150 mA	8 mA	280 mA
-48.0 V dc	2.00 V dc	48 mA	40 mA*	688 mA
-48.0 V dc	5.00 V dc	0 mA	10 mA**	160 mA
86.0 V ac	5.00 V ac	0 mA	10 mA***	160 mA
-150.0 V dc	3.00 V dc	0 mA	2 mA	32 mA

* Current required for each line off-hook
 ** Each active ringing relay requires 10 mA of battery voltage
 *** Reflects the current for ringing a single DN telephone. There may be as many as five ringers on each line.

Foreign and surge voltage protections

In-circuit protection against power line crosses or lightning is not provided on the analog message waiting line card. When the card is used to service off-premise telephones, primary and secondary MDF protection must be installed. Details on installing protection devices are given in “Off-premise line protection” on page 42. Off-premise telephones served by cable pairs routed through the central office, or crossing a public right-of-way, can be subject to a requirement for on-card protection, and MDF protectors may not be acceptable. Check local regulations before providing such service.

Environmental specifications

Table 55 lists the environmental specifications for the analog message waiting line card.

Table 55
Analog message waiting line card – environmental specifications

Parameter	Specifications
Operating temperature	0° to +60° C (+32 to +140° F), ambient
Operating humidity	5 to 95% RH (noncondensing)
Storage temperature	–40° to +70° C (–40° to +158° F)

Connector pin assignments

The analog message waiting line card brings the 16 phone lines to the IPE backplane through a 160-pin connector shroud. The backplane is cabled to the I/O panel on the rear of the module, which is then connected to the MDF by 25-pair cables.

Telephone lines from station equipment cross connect to the analog message waiting line card at the MDF using a wiring plan similar to that used for trunk cards. A typical connection example is shown in Figure 55 on page 217, and Table 56 on page 218 shows the I/O pin designations at the backplane connector. This connector is arranged as an 80-row by 2-column array of pins. Normally, these pin positions are cabled to 50-pin connectors at the I/O panel in the rear of each module for connection with 25-pair cables to the cross-connect terminal.

The information in Table 56 on page 218 is provided as a reference and diagnostic aid at the backplane, since the cabling arrangement may vary at the I/O panel. See *System Installation Procedures* (553-3001-210) for cable pinout information at the I/O panel.

Figure 55
Analog message waiting line card – typical cross connection example

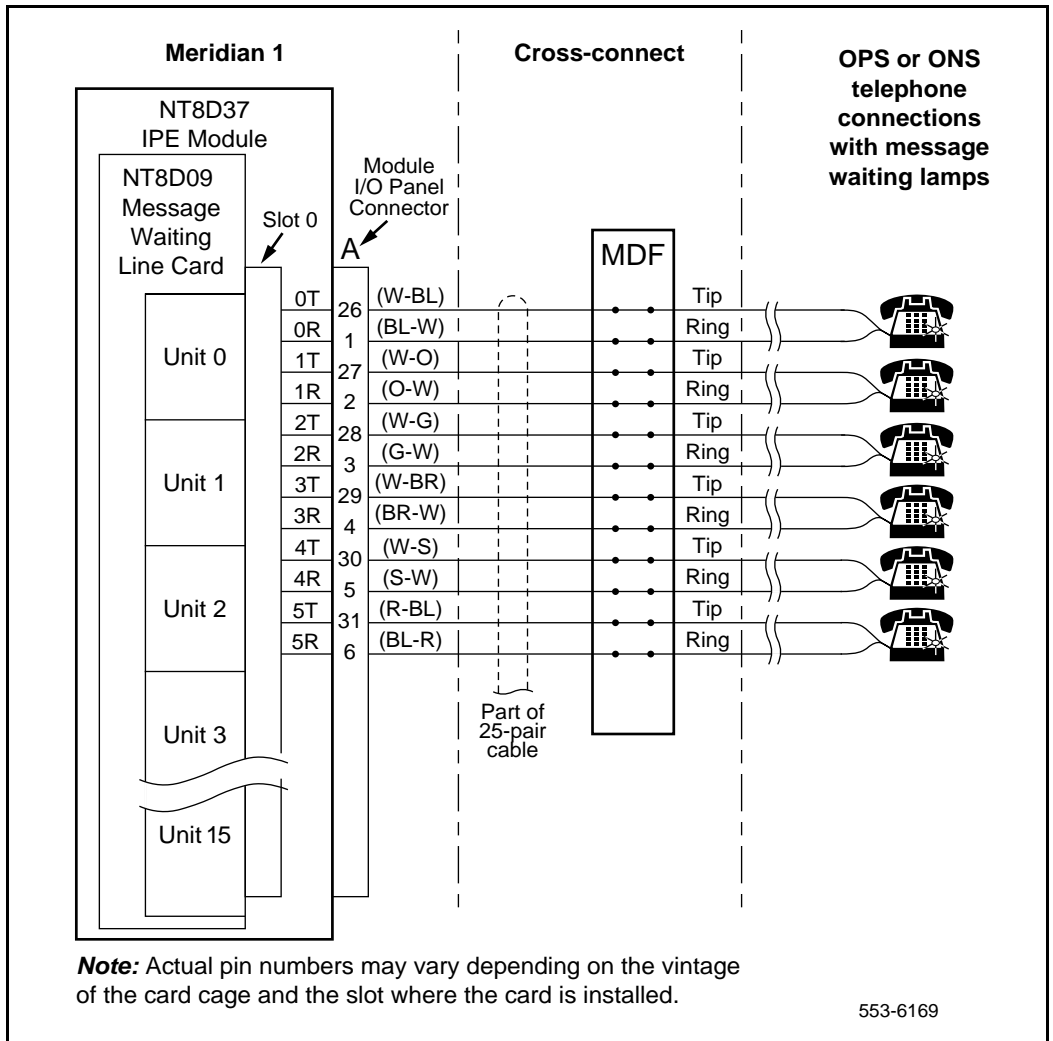

Table 56
Analog message waiting line card – backplane pinouts

Backplane pinout*	Lead designations	Backplane pinout*	Lead designations
12A	Line 0, Ring	12B	Line 0, Tip
13A	Line 1, Ring	13B	Line 1, Tip
14A	Line 2, Ring	14B	Line 2, Tip
15A	Line 3, Ring	15B	Line 3, Tip
16A	Line 4, Ring	16B	Line 4, Tip
17A	Line 5, Ring	17B	Line 5, Tip
18A	Line 6, Ring	18B	Line 6, Tip
19A	Line 7, Ring	18B	Line 7, Tip
62A	Line 8, Ring	62B	Line 8, Tip
63A	Line 9, Ring	63B	Line 9, Tip
64A	Line 10, Ring	64B	Line 10, Tip
65A	Line 11, Ring	65B	Line 11, Tip
66A	Line 12, Ring	66B	Line 12, Tip
67A	Line 13, Ring	67B	Line 13, Tip
68A	Line 14, Ring	68B	Line 14, Tip
69A	Line 15, Ring	69B	Line 15, Tip

* These pinouts apply to both NT8D37 and NT8D11 backplanes.

Configuration

This section outlines the procedures for configuring the switches and jumpers on the NT8D09 Analog Message Waiting Line Card and configuring the system software to properly recognize the card. Figure 56 on page 220 shows where the switches and jumper blocks are located on this board.

Jumper and switch settings

The NT8D09 Analog Message Waiting Line Card has no user-configurable jumpers or switches. The card derives its address from its position in the backplane and reports that information back to the Meridian 1 CPU through the LAN Link interface.

Software service changes

Individual line interface units on the NT8D09 Analog Message Waiting Line Card are configured using the Analog (500/2500-type) Telephone Administration program LD 10.

The message waiting feature is enabled by entering data into the customer data block using LD 15. See *Software Input/Output Guide Administration* (553-3001-311) for LD 10 and LD 15 service change instructions.

Analog message waiting line cards with a vintage later than NT8D09AK provide a fixed +2 dB transmission profile change in the gain of the D/A convertor. See Table 57 on page 219.

This transmission profile change is used for control of end-to-end connection loss. Control of such loss is a major element in controlling transmission parameters such as received volume, echo, noise, and crosstalk. The loss plan for the analog message waiting line card determines port-to-port loss between an analog line card unit (port) and other Meridian 1 IPE ports. LD 97 is used to configure the Meridian system for port-to-port loss. See *Software Input/Output Guide Administration* (553-3001-311) for LD 97 service change instructions.

Table 57
Transmission Profile Changes

Vintage	A/D convertor gain	D/A convertor gain
Previous to AK	-3.5 dB	-2.5 dB
AK and later	-3.5 dB	-0.5 dB

Figure 56
Analog message waiting line card – jumper block and switch locations

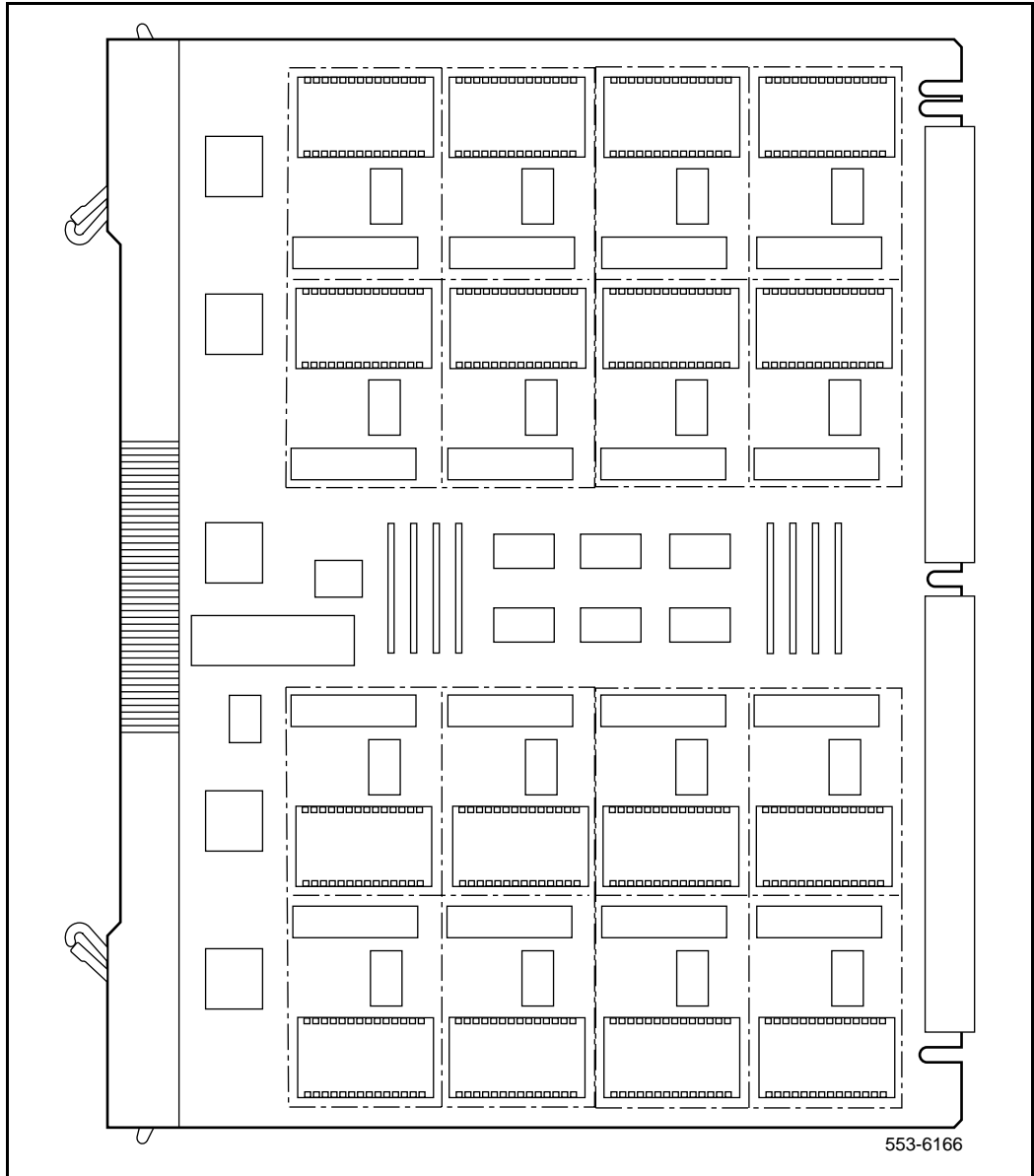

Index

Symbols

μ -Law companding support 23, 206

Numerics

500/2500 telephones
line card for 206

A

A-Law companding support 23, 206
analog line call operation 27
analog line cards 13
interface units 24
ASCII terminals
with NT8D02 Digital Line Card 192

B

balancing networks 25
BPRZ-AMI (Bi-Polar Return to Zero-Alternate
Mark Inversion) data 26, 196
busses

card LAN link 22
for DS-30X network loops 21
IPE compared to PE 17, 18

C

cabling
for line cards 17
NT1R20 Off-Premise Station (OPS) Analog
Line Card 48, 62
NT8D02 Digital Line Card 201
NT8D09 Analog Message Waiting Line Card
207

call signaling bits 21
campus installations (off-premise applications) 14,
25, 42
Card LAN link 22
NT1R20 Off-Premise Station (OPS) Analog
Line Card 51, 53
NT8D02 Digital Line Card 195, 198
NT8D09 Analog Message Waiting Line Card
210, 211
codecs (Coder/Decoder) 23, 24, 51
NT1R20 Off-Premise Station (OPS) Analog
Line Card 52
NT8D09 Analog Message Waiting Line Card
209, 210
connector pin assignments
NT1R20 Off-Premise Station (OPS) Analog
Line Card 57, 58
NT8D02 Digital Line Card 201, 202
NT8D09 Analog Message Waiting Line Card
216, 217, 218

D

data rates 21
data service simultaneous with voice 15
data valid bits 21
digital line call operation 34
digital line cards 13
interface units 26
DLIC (digital line interface circuit) 26, 196

DS-30X loops 18, 19, 20, 21
NT1R20 Off-Premise Station (OPS) Analog
Line Card 51, 52
NT8D02 Digital Line Card 195, 196
NT8D09 Analog Message Waiting Line Card
209, 210, 212
DS-30Y network loops 22

E

electrical specifications
NT1R20 Off-Premise Station (OPS) Analog
Line Card 54
NT5D60AA CLASS Modem card 189
NT8D02 Digital Line Card 199, 200
NT8D09 Analog Message Waiting Line Card
213
environmental specifications
NT1R20 Off-Premise Station (OPS) Analog
Line Card 56
NT8D02 Digital Line Card 189, 201
NT8D09 Analog Message Waiting Line Card
216

G

gain filters 24
glossary 227
grounding for line protection 44

I

impedance 25, 27
NT1R20 Off-Premise Station (OPS) Analog
Line Card 52, 54, 59, 60
NT8D02 Digital Line Card 199
NT8D09 Analog Message Waiting Line Card
213, 214
incoming (analog) calls 28
IPE (intelligent peripheral equipment)
architecture 19
comparison to PE modules 18
DS-30X loops 20, 21
installing line cards 16
line cards for 13, 14

J

jumpers 17
field selectable settings symbol 50
NT1R20 Off-Premise Station (OPS) Analog
Line Card 59, 61
NT8D02 Digital Line Card 203, 204
NT8D09 Analog Message Waiting Line Card
219, 220

K

key systems
line cards for 14, 15

L

LD 10 for configuring interface units 17, 59, 219
LD 11 for configuring interface units 17, 190, 203
LD 15 for configuring interface units 219
LD 97 for configuring interface units 219
line cards
for off-premise applications 14, 25, 42
installation 16
operation 34
analog line call connection sequence 27,
29, 30
analog line interface units 24
card LAN link 22
digital line interface units 26
DS-30X loops 20, 21
host interface bus 17
selecting 13
lines
number capacity of line cards 13
loop interfaces
TCM (time compressed multiplexed) data 27,
195, 196
loop limits
NT1R20 Off-Premise Station (OPS) Analog
Line Card 54
NT8D02 Digital Line Card 199
NT8D09 Analog Message Waiting Line Card
213

M

- MDF (main distribution frame)
 - connecting line cards 17
- Meridian 1 systems
 - related documentation 9
- message waiting handling
 - analog line calls 28, 31
 - analog line interface units 24, 25
 - characteristics of line cards 13, 14, 15
- microcontrollers 17, 18
 - on NT1R20 Off-Premise Station (OPS) Analog Line Card 51, 52
 - on NT8D02 Digital Line Card 195, 197
 - on NT8D09 Analog Message Waiting Line Card 210, 211
- modems
 - line cards for 15
 - with NT8D09 Analog Message Waiting Line Card 206

N

- NT1R20 Off-Premise Station (OPS) Analog Line Card
 - analog line electrical characteristics 54
 - applications 63, 64
 - transmission considerations 65, 67
 - configuration
 - jumper straps 59, 61
 - port-to-port loss 62, 65
 - software service changes 59, 60
 - connector pin assignments 57, 58
 - description 13, 14, 43, 47
 - environmental specification 56
 - faceplate 49, 50
 - foreign and surge voltage protection 55
 - functions
 - card control 52, 53
 - card interfaces 52
 - circuit power 53
 - codecs 51, 52
 - line interface units 52
 - power requirements 55
 - ring limitations 55

- NT5D11 Line Side T-1 Card
 - description 14
- NT5D11 Line Side T-1 Line Card
 - description 13
- NT5D60AA CLASS Modem card
 - configuration
 - software service changes 190
 - electrical characteristics 189
 - functions 186
 - power requirements 189
- NT8D02 Digital Line Card
 - configuration
 - jumper and switch settings 203, 204
 - software service changes 203
 - connector pin assignments 201, 202
 - description 13, 15, 26, 185, 191
 - electrical characteristics 199, 200
 - environmental specifications 189, 201
 - faceplate 186, 192, 193
 - foreign and surge voltage protection 200
 - functions 194, 195
 - card control 197
 - card interfaces 196
 - Card LAN interface 195, 198
 - digital line interfaces 195, 196
 - microcontroller 195, 197
 - sanity timer 198
 - TCM loop interface circuit 196
 - loop limits 199
 - power requirements 200
 - sanity timer 195, 197

NT8D09 Analog Message Waiting Line Card
configuration
 jumper and switch settings 219, 220
 software service changes 219
connector pin assignments 216, 217, 218
description 13, 15, 205, 207
electrical specifications 213
environmental specifications 216
faceplate 207, 208
foreign and surge voltage protection 216
frequency response 214
functions
 card control 211
 card interfaces 209
 circuit power 212
 codecs 209, 210
 line interface units 209, 210
 microcontroller 210, 211
loop limits 213
message channel noise 214
overload level 214
port-to-port loss 219
power requirements 215

O

off hook detection
 analog line interface units 24
off-hook detection
 analog line interface units 25
 analog lines 28
off-premise applications
 compared to off-premise extension (OPX)
 service 63
 line cards for 14, 25, 42
off-premise extension (OPX) service
 compared to off-premise station (OPS) service
 63
outgoing (analog) calls 28

P

PCM (pulse code modulated) voice data 21

PE (peripheral equipment)
 comparison to IPE modules 18
 installing line cards 16
 line cards for 13
port-to-port loss
 NT1R20 Off-Premise Station (OPS) Analog
 Line Card 62, 65
 NT8D09 Analog Message Waiting Line Card
 219
power requirements
 NT1R20 Off-Premise Station (OPS) Analog
 Line Card 51, 53, 55
 NT5D60AA CLASS Modem card 189
 NT8D02 Digital Line Card 200
 NT8D09 Analog Message Waiting Line Card
 215

R

related documentation 9
ringer limitations
 NT1R20 Off-Premise Station (OPS) Analog
 Line Card 55

S

signaling words 22
SLIC (subscriber line interface circuit) 25
switches 17

T

TCM (time compressed multiplexed) data 21, 26
 loop interfaces 27, 195, 196
terminal equipment
 connecting line cards 17
testing
 self-tests by IPE line cards 23
 self-tests by NT1R20 OPS card 49
timeslots 21
tip and ring facilities 15, 20, 27

V

variable gain filters 24
voice-only communication 15

voltage surge protection 14, 25, 43
 grounding 44
 NT1R20 Off-Premise Station (OPS) Analog
 Line Card 55
 NT8D02 Digital Line Card 200
 NT8D09 Analog Message Waiting Line Card
 216

List of terms

BIMP

Balance Impedance

CCITT

International Telegraph and Telephone Consultive Committee

CID

Caller Identification

CLS

Class of service

CO

Central office

COS

Class of service

CP

Core processor

CPE

Customer Premise Equipment

CSU

Channel Service Unit

DTMF

Dual-tone multi-frequency

ICL	Inserted connection loss
IPE	Intelligent peripheral equipment
LAN	Local area network
LED	Light emitting diode
MDF	Main Distribution Frame
MMI	Man-Machine Interface
ONP	On-premise class of service
ONS	On-premises set (station)
OPS	Off-premises set (station)
OPX	Off-premise class of service
PBX	Private branch exchange
PCM	Pulse code modulation
PSTN	Public Switched Telephone Network

PE	Peripheral equipment
PSN	Public switched network
PSTN	Public switched telephone network
REN	Ringer equivalence numbers
RH	Relative humidity
Rsync	Ring synchronization
TCN	Time compression multiplexed
TIMP	Termination impedance
TN	Terminal number
WATS	Wide-Area Transmission Service

Meridian 1

Line Cards

Description

Copyright © 1994 –2002 Nortel Networks
All Rights Reserved

Information is subject to change without notice. Nortel Networks reserves the right to make changes in design or components as progress in engineering and manufacturing may warrant. This equipment has been tested and found to comply with the limits for a Class A digital device pursuant to Part 15 of the FCC rules, and the radio interference regulations of Industry Canada. These limits are designed to provide reasonable protection against harmful interference when the equipment is operated in a commercial environment. This equipment generates, uses and can radiate radio frequency energy, and if not installed and used in accordance with the instruction manual, may cause harmful interference to radio communications. Operation of this equipment in a residential area is likely to cause harmful interference in which case the user will be required to correct the interference at their own expense.

SL-1 and Meridian 1 are trademarks of Nortel Networks.

Publication number: 553-3001-105

Document release: Standard 7.00

Date: January 2002

Printed in Canada

