

---

Meridian 1

# Trunk Cards

## Description

---

Document Number: 553-3001-106

Document Release: Standard 7.00

Date: January 2002

---

Copyright © 1994 – 2002 Nortel Networks  
All Rights Reserved

Printed in Canada

Information is subject to change without notice. Nortel Networks reserves the right to make changes in design or components as progress in engineering and manufacturing may warrant. This equipment has been tested and found to comply with the limits for a Class A digital device pursuant to Part 15 of the FCC rules, and the radio interference regulations of Industry Canada. These limits are designed to provide reasonable protection against harmful interference when the equipment is operated in a commercial environment. This equipment generates, uses and can radiate radio frequency energy, and if not installed and used in accordance with the instruction manual, may cause harmful interference to radio communications. Operation of this equipment in a residential area is likely to cause harmful interference in which case the user will be required to correct the interference at their own expense.

SL-1 and Meridian 1 are trademarks of Nortel Networks.

---



---

## Revision history

---

### January 2002

Standard 7.00. This document is up-issued to include content changes for Meridian 1 Internet Enabled Release 25.40.

### April 2000

Standard 6.00. This is a global document and is up-issued for X11 Release 25.0x. Document changes include removal of: redundant content; references to equipment types except Options 11C, 51C, 61C, and 81C; and references to previous software releases. This document incorporates the *Generic Central Office Trunk Cards description and installation (553-3001-174)*.

### October 1997

Standard, release 5.00. This document is reissued to include information on the NT8D14BB (Release 10 and later), which provides identical functionality as the NT8D14 Universal Trunk card, but which has only three jumpers instead of the four present on previous versions of this card.

### August 1996

Standard, release 4.00. Changes are noted by revision bars in the margins.

### August 1996

Standard, release 3.00. Changes are noted by revision bars in the margins.

### July 1995

Standard, release 2.00. This document is reissued to incorporate technical corrections and indexing. Changes are noted by revision bars in the margins.

### December 1994

Standard, release 1.00. This is the initial release of this document. It supersedes:

- *QPC71 E&M/DX Signaling and Paging Trunk Card description (553-2001-187)*

- *Recorded Telephone Dictation Trunk Cards description (553-2001-188)*
- *QPC237 4-Wire E&M/DX Trunk Card description (553-2001-190)*
- *CO/FX/WATS Trunk Cards description (553-2201-185)*
- *QPC449 Loop Signaling Trunk Cards description (553-2201-186)*
- *QPC74 Recorded Announcement Trunk Card description (553-2201-194)*
- *NT8D14 Universal Trunk Card description (553-3001-171)*
- *NT8D15 E&M Trunk Card description (553-3001-172)*

---

# Contents

---

<a href="#">About this document</a> .....	7
<a href="#">Description</a> .....	9
<a href="#">NT8D14 Universal Trunk Card</a> .....	23
<a href="#">NT8D15 E&amp;M Trunk Card</a> .....	79
<a href="#">NTCK16 Generic Central Office Trunk Cards</a> ...	117



---

## About this document

---

This document is a global document. Contact your system supplier or your Nortel Networks representative to verify that the hardware and software described is supported in your area.

This document outlines the functions, specifications, applications, and operation of the various Meridian 1 trunk cards. This information is intended to be used as a guide when connecting the trunk cards to customer-provided equipment and central office trunk facilities.

## References

See the Meridian 1 system planning and engineering guides for

- *System Engineering* (553-3001-151)
- *Spares Planning* (553-3001-153)
- *Equipment Identification* (553-3001-154)
- *Summary of Transmission Parameters* (553-2201-182)

See the Meridian 1 system installation and maintenance guides for

- *System Installation Procedures* (553-3001-210)
- *Circuit Card: Installation and Testing* (553-3001-211)
- *General Maintenance Information* (553-3001-500)
- *Fault Clearing* (553-3001-510)
- *Hardware Replacement* (553-3001-520)

See the software guides for an overview of software architecture, procedures for software installation and management, and a detailed description of the features and services. This information is contained in two documents:

- *System Management* (553-3001-300)
- *Features and Services* (553-3001-306)

See the *Software Input/Output Guide Administration* (553-3001-311) for a description of all administration and maintenance programs, and *Software Input/Output Guides Message Guide* (553-3001-411) for information about system messages.



---

# Description

---

## Contents

This section contains information on the following topics:

Overview .....	9
Selecting a trunk card .....	10
Intelligent peripheral equipment (IPE) trunk cards .....	10
Installation .....	11
Operation .....	13
Host interface bus .....	13
Trunk interface unit .....	20

## Reference list

The following are the references in this section:

- *System Engineering* (553-3001-151)
- *Circuit Card: Installation and Testing* (553-3001-211)

## Overview

This document describes the various trunk cards that are used with the Meridian 1 switch. It describes the Meridian 1 architecture, the trunk cards themselves, and how the cards fit into the Meridian 1 architecture. It also shows how the cards are used at the customer site, and how they are installed and programmed. It also provides detailed technical specifications on each of the cards.

The following trunk cards are described in this document:

- NT8D14 Universal Trunk Card

- NT8D15 E&M Trunk Card
- NTCK16 Generic Central Office Trunk Cards

## Selecting a trunk card

Each of the trunk cards was designed to fit a specific system need. Use Table 1 to help select the trunk card that will best meet system needs.

**Table 1**  
**Trunk card characteristics**

Part Number	Description	Trunks	Trunk Types	Architecture
NT8D14	Universal Trunk Card	8	CO/FX/WATS trunks*, direct inward dial trunks, TIE trunks, Loop Dial Repeating trunks Recorded Announcement trunks, Paging trunks	IPE
NT8D15	E&M Trunk Card	4	2-wire E&M trunks, 4-wire E&M trunks, 4-wire DX trunks, Paging trunks	IPE
NTCK16	Generic Central Office Trunk Card	8	CO trunks	IPE

\* Central office (CO), Foreign Exchange (FX), and Wide Area Telephone Service (WATS) trunks.

## Intelligent peripheral equipment (IPE) trunk cards

The following trunk cards are designed using the intelligent peripheral equipment (IPE) architecture, and are recommended for use in all new system designs.

### NT8D14 Universal Trunk Card

The NT8D14 Universal Trunk Card is an intelligent four-channel trunk card that is designed to be used in a variety of applications. It supports the following five trunk types:

- Central office (CO), Foreign Exchange (FEX), and Wide Area Telephone Service (WATS) trunks

- Direct Inward Dial (DID) trunks
- TIE trunks: two-way Loop Dial Repeating (LDR) and two-way loop Outgoing Automatic Incoming Dial (OAID)
- Recorded Announcement (RAN) trunks
- Paging (PAG) trunks

The universal trunk card also supports Music, Automatic Wake Up, and Direct Inward System Access (DISA) features.

### **NT8D15 E&M Trunk Card**

The NT8D15 E&M Trunk Card is an intelligent four-channel trunk card that is designed to be used when connecting to the following types of trunks:

- 2-wire E&M Type I signaling trunks
- 4-wire E&M trunks with:
  - Type I or Type II signaling
  - Duplex (DX) signaling
- Paging (PAG) trunks

The trunk type and function can be configured on a per port basis. Dialing outpulsing is provided on the card. Make and break ratios are defined in software and downloaded by software commands.

### **NTCK16 Generic Central Office Trunk Card**

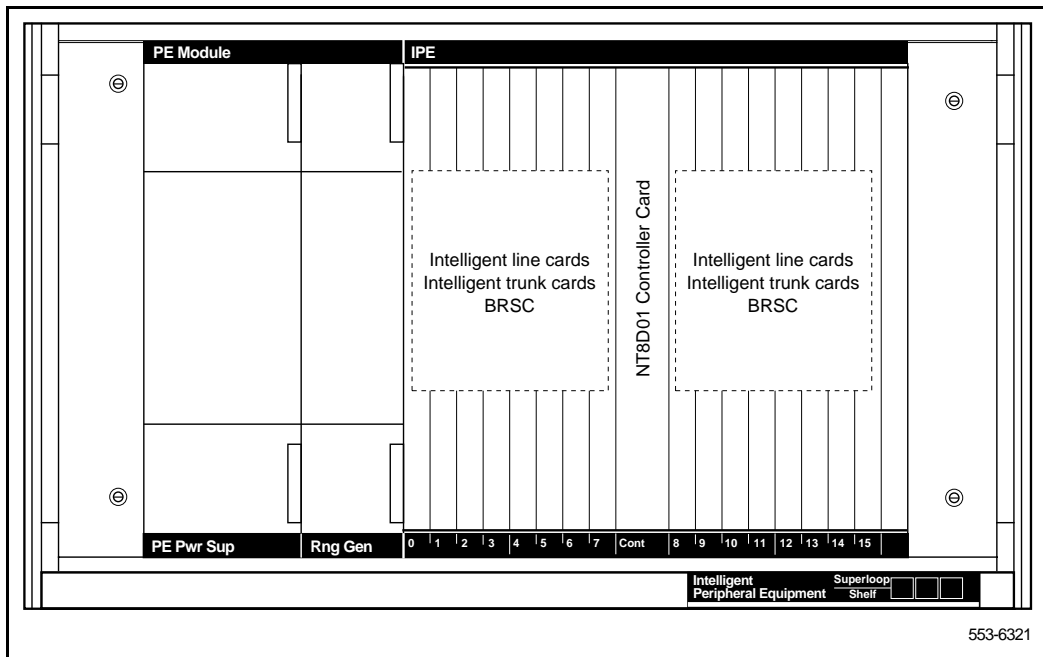
The NTCK16 generic central office trunk cards support up to eight analog central office trunks. They can be installed in any PE slot that supports intelligent peripheral equipment (IPE). The cards are available with or without the Periodic Pulse Metering (PPM) feature. The cards are also available in numerous countries.

## **Installation**

This section provides a high-level description of how to install and test trunk cards. For specific installation instructions, see *Circuit Card: Installation and Testing* (553-3001-211).

Intelligent peripheral equipment (IPE) trunk cards can be installed in any IPE slot of the NT8D37 Intelligent Peripheral Equipment (IPE) Module. Figure 1 shows where an IPE trunk card can be installed in an NT8D37 IPE Module.

**Figure 1**  
**IPE trunk cards installed in an NT8D37 IPE Module**



When installing trunk cards, these general procedures should be used:

- 1 Configure the jumpers and switches on the trunk card (if any) to meet the system needs.
- 2 Install the trunk card into the selected slot.
- 3 Install the cable that connects the backplane connector on the PE or IPE module to the module I/O panel.
- 4 Connect a 25-pair cable from the module I/O panel connector to the Main Distribution Frame (MDF).

- 5 Connect the trunk card output to the selected terminal equipment at the MDF.
- 6 Configure the individual trunk interface unit using the Trunk Administration program (LD 14) and the Trunk Route Administration program (LD 16).

Once these steps have been completed, the trunk card is ready for use.

## Operation

This section describes how trunk cards fit into the Meridian 1 architecture, the buses that carry signals to and from the trunk cards, and how they connect to terminal equipment. See Table 2 on page 14 for IPE parameters.

### Host interface bus

Cards based on the IPE bus have a built-in microcontroller. The IPE microcontroller is used for the following:

- to perform local diagnostics (self-test)
- to configure the card according to instructions issued by the Meridian 1 system processor
- to report back to the Meridian 1 system processor information such as card identification (type, vintage, and serial number), firmware version, and programmed configuration status.

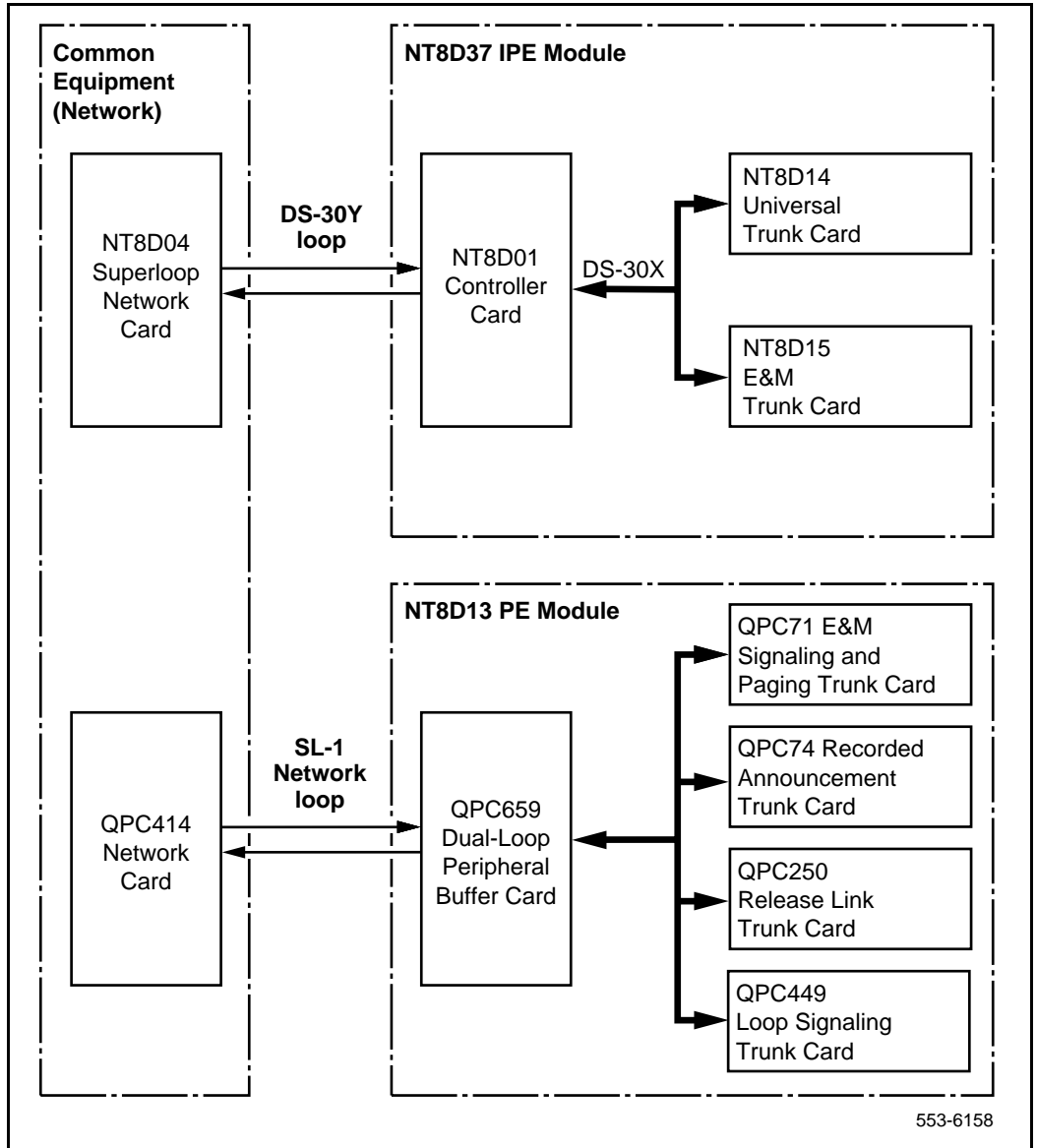
**Table 2**  
**Differences between IPE parameters**

Parameter	Intelligent Peripheral Equipment
Card Dimensions	31.75 x 25.4 x 2.2 cm. (12.5 x10.0 x 0.875 in.)
Network Interface	DS-30X Loops
Communications Interface	card LAN Link
Microcontroller	8031
Peripheral Interface Card	NT8D01 Controller Card
Network Interface Card	NT8D04 Superloop Network Card
Modules	NT8D37 IPE Module

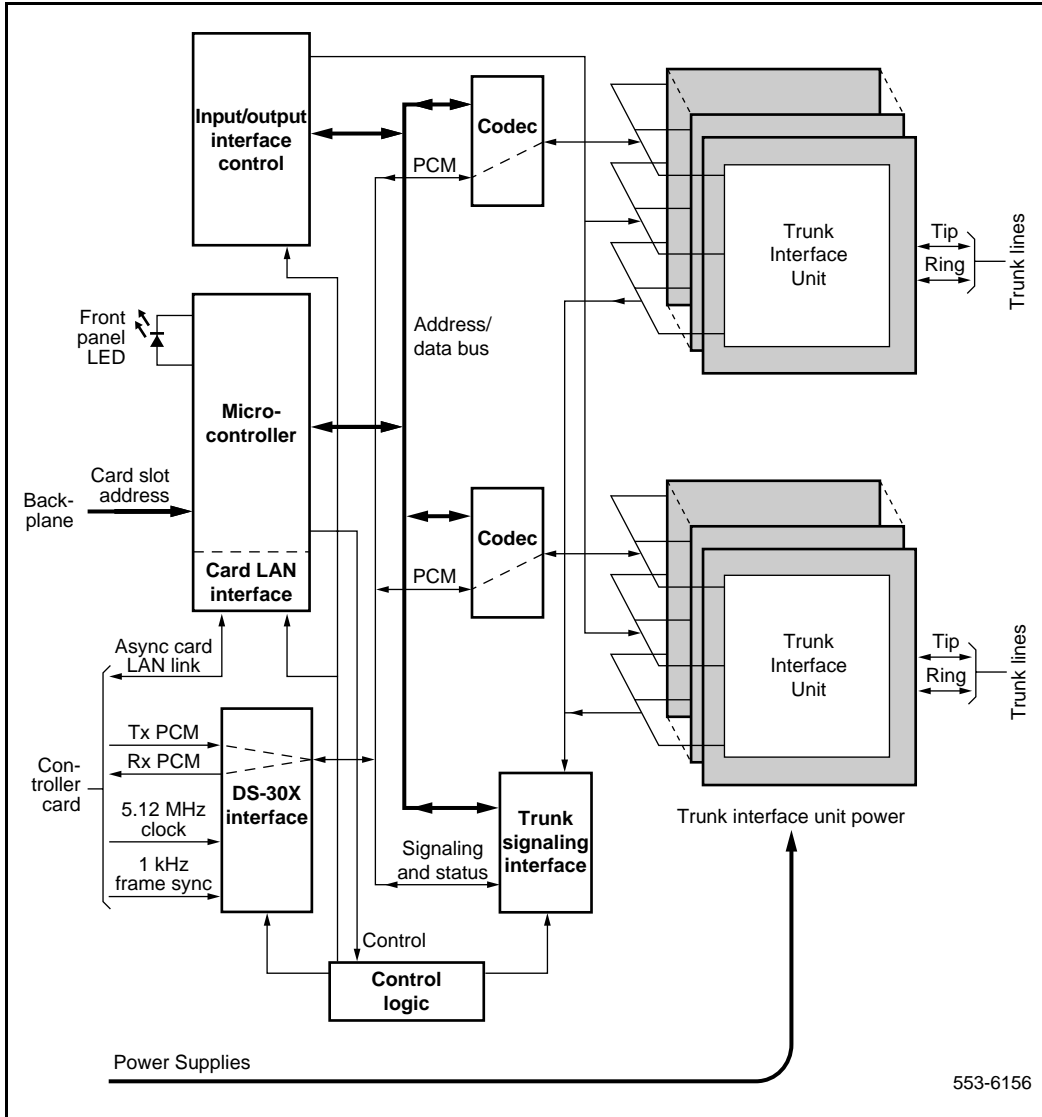
**Intelligent peripheral equipment**

IPE trunk cards all have a similar architecture. Figure 3 on page 16 shows a typical IPE trunk card architecture. The various trunk cards differ only in the number and types of trunk interface units.

**Figure 2**  
**Network connections to PE/IPE modules**



**Figure 3**  
**Typical IPE trunk card architecture**





The Meridian 1 switch communicates with IPE modules over two separate interfaces. Voice and signaling data are sent and received over DS-30X loops and maintenance data is sent over a separate asynchronous communications link called the card LAN link.

Signaling data is information directly related to the operation of the telephone line. Some examples of signaling commands are as follows:

- off hook/on hook
- ringing signal on/off
- message waiting lamp on/off

Maintenance data is data relating to the setup and operation of the IPE card, and is carried on the card LAN link. Some examples of Maintenance data are as follows:

- polling
- reporting of self-test status
- CPU initiated card reset
- reporting of card ID (card type and hardware vintage)
- reporting of firmware version
- downloading trunk interface unit configuration
- reporting of trunk interface unit configuration
- enabling/disabling of the DS-30X network loop bus
- reporting of card status

### ***DS-30X loops***

The interfaces provided by the line and trunk cards connect to conventional 2-wire (tip and ring) line facilities. IPE analog line and trunk cards convert the incoming analog voice and signaling information to digital form, and route it to the Meridian 1 Common Equipment (CE) CPU over DS-30X network loops. Conversely, digital voice and signaling information from the CPU is sent over DS-30X network loops to the analog line and trunk cards where it is converted to analog form and applied to the line or trunk facility.

IPE digital line cards receive the data from the digital phone terminal as 512 kHz Time Compressed Multiplexed (TCM) data. The digital line card converts that data to a format compatible with the DS-30X loop, and transmits it in the next available timeslot. When a word is received from the DS-30X loop, the digital line card converts it to the TCM format and transmits it to the digital phone terminal over the digital line facility.

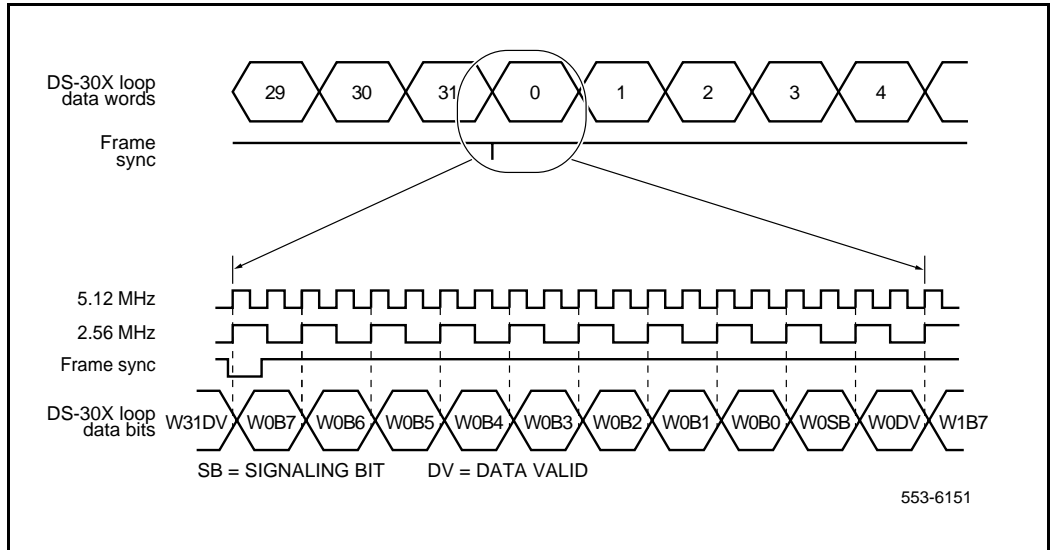
A separate dedicated DS-30X network loop is extended between each IPE line/trunk card and the controller cards within an IPE module (or the controller circuits on a network/DTR card in a CE/PE module). A DS-30X network loop is composed of two synchronous serial data buses. One bus transports in the transmit (Tx) direction toward the line facility and the other in the receive (Rx) direction toward the Meridian 1 common equipment.

Each bus has 32 channels for pulse code modulated (PCM) voice data. Each channel consists of a 10-bit word. See Figure 4 on page 19.

Eight of the 10 bits are for PCM data, one bit is the call signaling bit, and the last bit is a data valid bit. The 8-bit PCM portion of a channel is called a *timeslot*. The DS-30X loop is clocked at 2.56 Mbps (one-half the 5.12 MHz clock frequency supplied by the controller card). Thus, the timeslot repetition rate for a single channel is 8 kHz. The controller card also supplies a locally generated 1 kHz frame sync signal for channel synchronization.

Signaling data is transmitted to and from the line cards using the call signaling bit within the 10-bit channel. When the line card detects a condition that the Meridian 1 switch needs to know about, it creates a 24-bit signaling word. This word is shifted out on the signaling bit for the associated channel one bit at a time during 24 successive DS-30X frames. Conversely, when the Meridian 1 switch sends signaling data to the line card, it is sent as a 24-bit word divided among 24 successive DS-30X frames.

**Figure 4**  
**DS-30X loop data format**



DS-30Y network loops extend between controller cards and superloop network cards in the common equipment, and function in a manner similar to DS-30X loops. See Figure 2 on page 15.

Essentially, a DS-30Y loop carries the PCM timeslot traffic of a DS-30X loop. Four DS-30Y network loops form a *superloop* with a capacity of 128 channels (120 usable timeslots).

See *System Engineering* (553-3001-151) for more information on superloops.

### **Card LAN link**

Maintenance communications is the exchange of control and status data between IPE line or trunk cards and the CE CPU by way of the NT8D01 Controller Card. Maintenance data is transported via the *card LAN* link. This link is composed of two asynchronous serial buses (called the Async card LAN link in Figure 3 on page 16). The output bus is used by the Meridian 1 controller for output of control data to the trunk card. The input bus is used by the Meridian 1 controller for input of trunk card status data.

A card LAN link bus is common to all of the line/trunk card slots within an IPE module (or IPE section of a CE/PE module). This bus is arranged in a master/slave configuration where the controller card is the master and all other cards are slaves. The module backplane provides each line/trunk card slot with a unique hardwired slot address. This slot address enables a slave card to respond when addressed by the controller card. The controller card communicates with only one slave at a time.

In normal operation, the controller card continually scans (polls) all of the slave cards connected to the card LAN to monitor their presence and operational status. The slave card sends replies to the controller on the input bus along with its card slot address for identification. In this reply, the slave informs the controller if any change in card status has taken place. The controller can then prompt the slave for specific information. Slaves only respond when prompted by the controller; they do not initiate exchange of control or status data on their own.

When an IPE line or trunk card is first plugged into the backplane, it runs a self-test. When the self test is completed, a properly functioning card responds to the next controller card poll with the self-test status. The controller then queries for card identification and other status information. The controller then downloads all applicable configuration data to the line/trunk card, initializes it, and puts it into an operational mode.

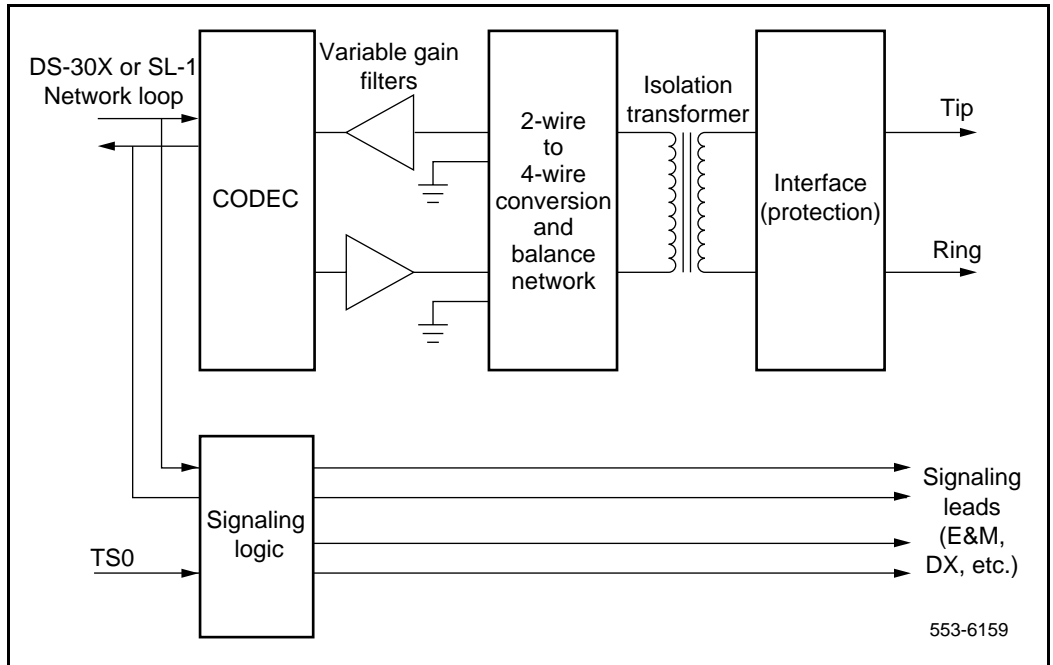
The network card regularly polls the PE cards during TS0 to see if any of them has a message to be sent. When a PE card has a message waiting it responds to the poll by sending a series of 1s during the next five successive timeslot 0s. The network card responds by sending a “message send enable” message (all 1s). The PE card replies by sending 1, 1, 1, 0, and then the message in successive timeslot 0s.

## **Trunk interface unit**

Once the 8-bit digital voice signal has been received by the trunk card, it must be converted back into an analog signal, filtered, and driven onto the analog trunk line through an impedance matching and balance network. The trunk interface also includes the logic necessary to place outgoing call signaling onto the trunk, or the logic to connect to special services such as recorded announcement and paging equipment.

Figure 5 shows a typical example of the logic that performs these functions. Each part of the trunk interface unit is discussed in the following section.

**Figure 5**  
**Typical trunk interface unit block diagram**



### ***Coder/Decoder circuit***

The Coder/Decoder (Codec) performs Analog to Digital (A/D) and Digital to Analog (D/A) conversion of the line analog voiceband signal to and from a digital PCM signal. This signal can be coded and decoded using either the A-Law or the  $\mu$ -Law companding algorithm. On some trunk cards the decoding algorithm depends of the type of Codec installed when the board is built. On others, it is an option selected using a software overlay.

### ***Variable gain filters***

Audio signals received from the analog phone trunk are passed through a low-pass A/D monolithic filter that limits the frequency spread of the input signal to a nominal 200–3400 Hz bandwidth. The audio signal is then applied to the input of the Codec. Audio signals coming from the Codec are passed through a low-pass A/D monolithic filter that integrates the amplitude modulated pulses coming from the Codec, and then filters and amplifies the result.

On some of the trunk cards, the gain of these filters can be programmed by the system controller. This allows the system to make up for line losses according to the loss plan.

### ***Balancing network***

Depending on the card type, the balancing network is capable of providing either a 600 ohm or a 900 ohm (or both) impedance matching network. It also converts the 2-wire transmission path (tip and ring) to a 4-wire transmission path (Rx/ground and Tx/ground). The balancing network is a transformer/analog (hybrid) circuit combination.

### ***Signaling circuits***

Signaling circuits are relays that place outgoing call signaling onto the trunk. Signal detection circuits monitor the incoming call signaling.

### ***Control signals***

Control signals and logic are provided when the trunk is going to be connected to special services such as recorded announcement and paging equipment.

---

# NT8D14 Universal Trunk Card

---

## Contents

This section contains information on the following topics:

Reference list .....	24
Introduction .....	24
Physical description .....	25
Functional description .....	28
Card interfaces .....	29
Card control functions .....	30
Operation .....	31
Loop start operation .....	31
Ground start operation .....	36
Direct inward dial operation .....	42
Two-way, loop dial repeating, TIE trunk operation .....	42
Senderized operation for DID and two-way loop DR trunks .....	50
Outgoing automatic, incoming dial operation .....	53
Recorded announcement trunk operation .....	58
Electrical specifications .....	64
Power requirements .....	65
Foreign and surge voltage protection .....	65
Environmental specifications .....	65
Connector pin assignments .....	66
Configuration .....	69

Jumper strap settings .....	69
Service change entries .....	69
Applications .....	77
Paging trunk operation .....	77
Music operation .....	78

## Reference list

The following are the references in this section:

- *System Installation Procedures (553-3001-210)*
- *Circuit Card: Installation and Testing (553-3001-211)*
- *Software Input/Output Guide Administration (553-3001-311)*

## Introduction

The NT8D14 Universal trunk Card is an Intelligent Peripheral Equipment (IPE) device that can be installed in either the NT8D37 IPE Module or the NT8D11 CE/PE Module. The Universal Trunk card interfaces eight analog trunk lines to the Meridian 1 switch. Each trunk interface is independently configurable by software control using the Trunk Administration program LD 14.

The universal trunk card supports the following trunk types:

- Centralized Automatic Message Accounting (CAMA) trunks
- Central office (CO), Foreign Exchange (FEX), and Wide Area Telephone Service (WATS) trunks
- Direct inward dial (DID) trunks
- TIE trunks: two-way loop dial repeating (LDR) and two-way loop outgoing automatic incoming dial (OAID)
- Recorded Announcement (RAN) trunks
- Paging trunks

The universal trunk card also supports Music, Automatic Wake Up, and Direct Inward System Access (DISA) features.



Table 3 lists the signaling and trunk types supported by the universal trunk card.

**Table 3**  
**Trunk and signaling matrix**

Signaling type	Trunk types					
	CO/FX/ WATS	DID	Tie	RAN	Paging	CAMA
Loop start	Yes	No (see note)	No	N/A	N/A	Yes
Ground start	Yes	No	No	N/A	N/A	No
Loop DR	No	Yes	Yes	N/A	N/A	No
Loop OAID	No	No	Yes	N/A	N/A	No
Continuous operation mode	No	No	No	Yes	N/A	No
Start modes (pulse and level)	No	No	No	Yes	N/A	No
<b>Note:</b> For incoming and outgoing service, DID trunks must be programmed as loop dial repeating.						

## Physical description

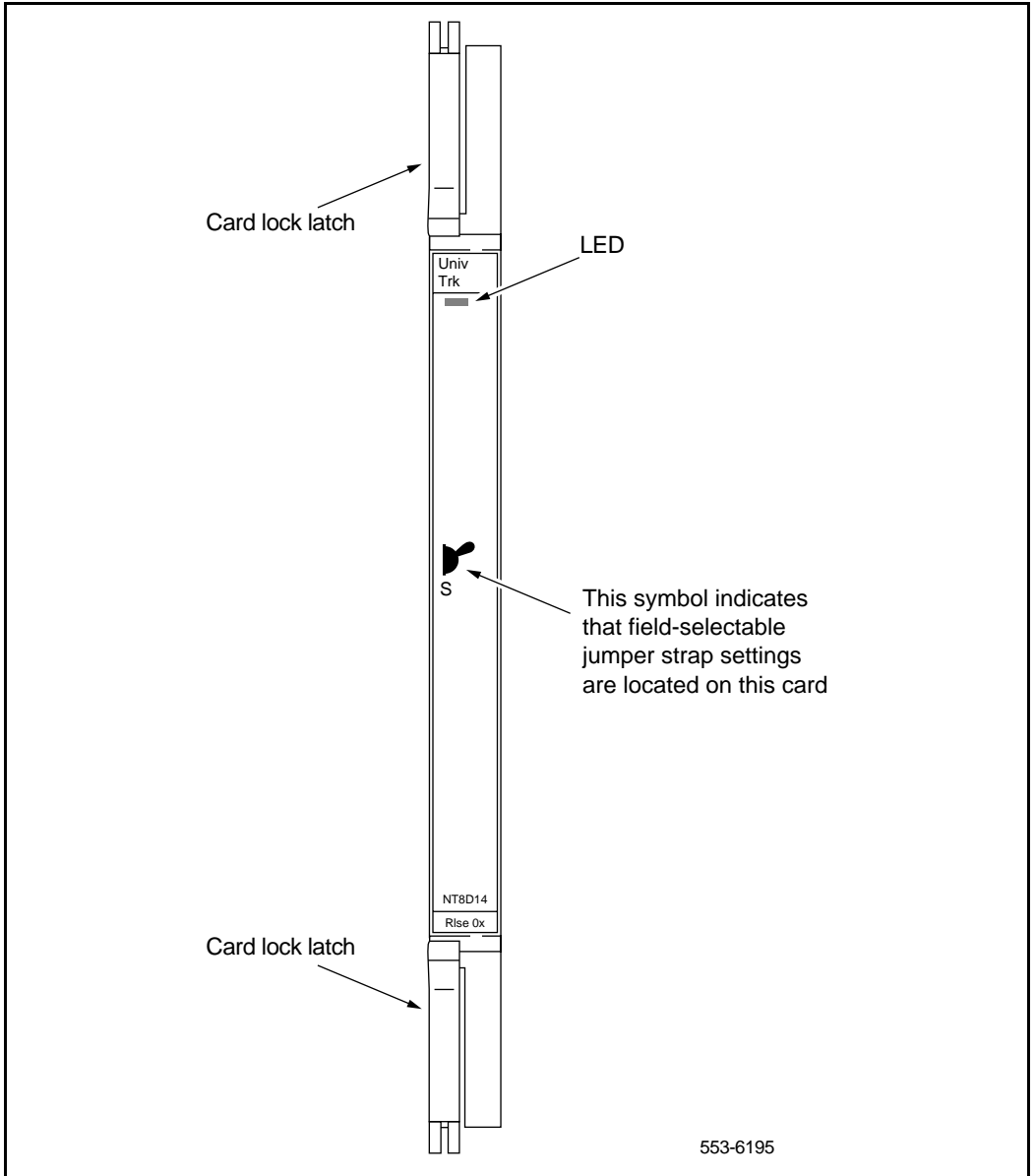
The universal trunk card mounts in any IPE slot. The trunk and common multiplexing circuitry is mounted on a 31.75 cm by 25.40 cm (12.5 in. by 10 in.) printed circuit board.

The universal trunk card connects to the backplane through a 160-pin connector shroud. The backplane is cabled to the I/O panel, which is cabled to the Main Distribution Frame (MDF) by 25-pair cables. External equipment, such as recorded announcement machines, paging equipment, and central office facilities, connect to the card at the MDF.

See *System Installation Procedures* (553-3001-210) for termination and cross-connect information.

The faceplate of the card is equipped with a red LED. See Figure 6 on page 27. When a universal trunk card is installed, the LED remains lit for 2 to 5 seconds while the self-test runs. If the self-test completes successfully, the LED flashes three times and remains lit until the card is configured and enabled in software, then the LED goes out. If the LED flashes continuously or remains weakly lit, replace the card.

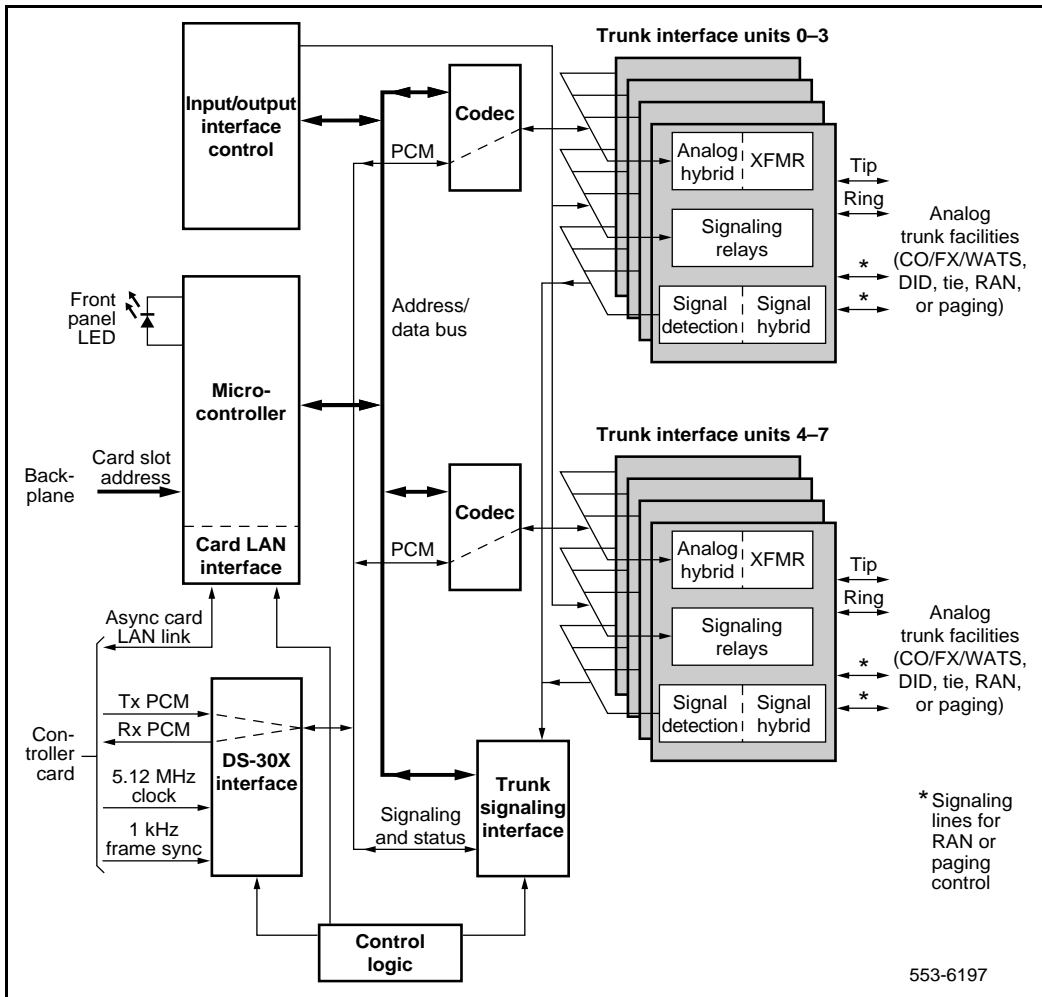
Figure 6  
Universal trunk card – faceplate



## Functional description

Figure 7 shows a block diagram of the major functions contained on the universal trunk card. Each of these functions are described on the following pages.

**Figure 7**  
**Universal trunk card – block diagram**



## Card interfaces

The universal trunk card passes voice and signaling data over DS-30X loops, and maintenance data over the card LAN link. These interfaces are described in “Typical IPE trunk card architecture” on page 16.

### Trunk interface units

The universal trunk card contains eight identical and independently configurable trunk interface units (also referred to as circuits). Each unit provides impedance matching and a balance network in a signal transformer/analog hybrid circuit.

Also provided are relays for placing outgoing call signaling onto the trunk. Signal detection circuits monitor incoming call signaling. Two Codecs are provided for performing A/D and D/A conversion of trunk analog voiceband signals to digital PCM signals. Each Codec supports four trunk interface units. The following features are common to all units on the card:

- trunk type configurable on a per unit basis
- terminating impedance (600 or 900 ohm) selectable on a per unit basis (minimum vintage BA)
- balance impedance (600 or 900 ohm or complex impedance network) selectable on a per unit basis (minimum vintage BA)
- control signals provided for RAN and paging equipment
- loopback of PCM signals received from trunk facility over DS-30X network loop for diagnostic purposes
- switchable pads for transmission loss control

## Card control functions

Control functions are provided by a microcontroller, a card LAN interface, and signaling and control circuits on the universal trunk card.

### Microcontroller

The universal trunk card contains a microcontroller that controls the internal operation of the card and the serial card LAN link to the controller card. The microcontroller controls the following:

- reporting to the CE CPU via the card LAN link:
  - card identification (card type, vintage, and serial number)
  - firmware version
  - self-test status
  - programmed configuration status
  
- receipt and implementation of card configuration via the card LAN link:
  - programming of the Codecs
  - enabling/disabling of individual units or entire card
  - programming of input/output interface control circuits for administration of trunk interface unit operation
  - maintenance diagnostics
  - transmission pad settings

### Card LAN interface

Maintenance data is exchanged with the common equipment CPU over a dedicated asynchronous serial network called the Card LAN link. The card LAN link is described in “Typical IPE trunk card architecture” on page 16.

### Signaling and control

The signaling and control portion of the card provides circuits that establish, supervise, and take down call connections. These circuits work with the system CPU to operate trunk interface circuits during calls. The circuits receive outgoing call signaling messages from the CPU and return incoming call status information over the DS-30X network loop.

## Operation

The optional applications, features, and signaling arrangements for each unit on the universal trunk card are assigned through the Trunk Administration LD 14 and Trunk Route Administration LD 16 programs and/or jumper strap settings on the card.

See *Software Input/Output Guide Administration* (553-3001-311) for detailed information on assigning features and services to trunks.

### Loop start operation

Loop start operation is configured in software and is implemented in the card through software download messages. When the universal trunk card is idle, it provides a high impedance toward the CO for isolation and AC (ringing) detection.

#### Incoming calls

The alerting signal into the Meridian 1 is 20 Hz (nominal) ringing sent by the CO. When an incoming call is answered, ringing is tripped when the Meridian 1 places a low-resistance dc loop across the tip and ring leads toward the CO. See Figure 8 on page 32 and Figure 9 on page 33.

#### Outgoing calls

For outgoing calls from the Meridian 1, software sends an outgoing seizure message to place a low-resistance loop across the tip and ring leads toward the CO (see Figures 10 and 11). When the CO detects the low-resistance loop, it prepares to receive digits. When the CO is ready to receive digits, it returns dial tone. Outward address signaling is then applied from the Meridian 1 in the form of loop (interrupting) dial pulses or DTMF tones.

#### ***Polarity-sensitive-insensitive packs feature***

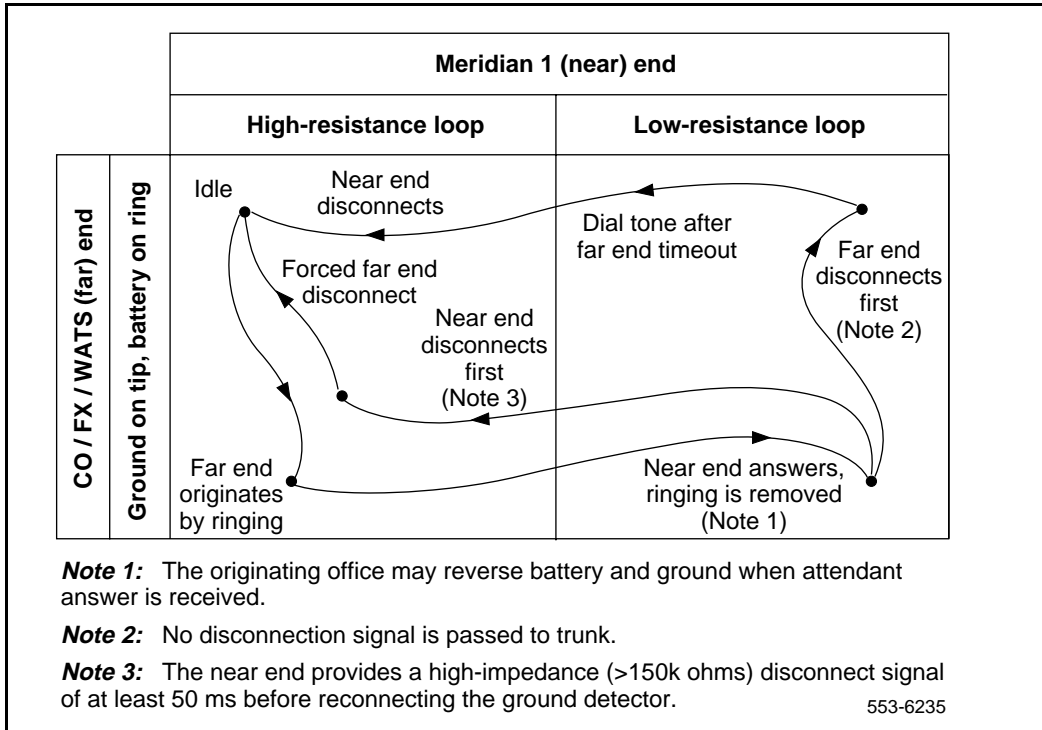
The Meridian 1 software provides the Polarity-Sensitive/Insensitive Packs (PSP and PIP) feature for the accurate recording of outgoing call duration for loop start and ground start operation.

On trunks equipped with far-end answer supervision, the PSP class of service is enabled in software and causes call-duration recording in CDR records to begin only upon receipt of answer supervision from the far-end.

For trunks not equipped with answer supervision, the PIP class of service is enabled and call-duration recording begins immediately upon near-end trunk seizure.

The PSP and PIP classes of service are enabled in the Trunk Administration program (LD 14).

**Figure 8**  
**Loop start call states – incoming call from CO/FX/WATS**





**Figure 9**  
**Loop start call connection sequence – incoming call from CO/FX/WATS**

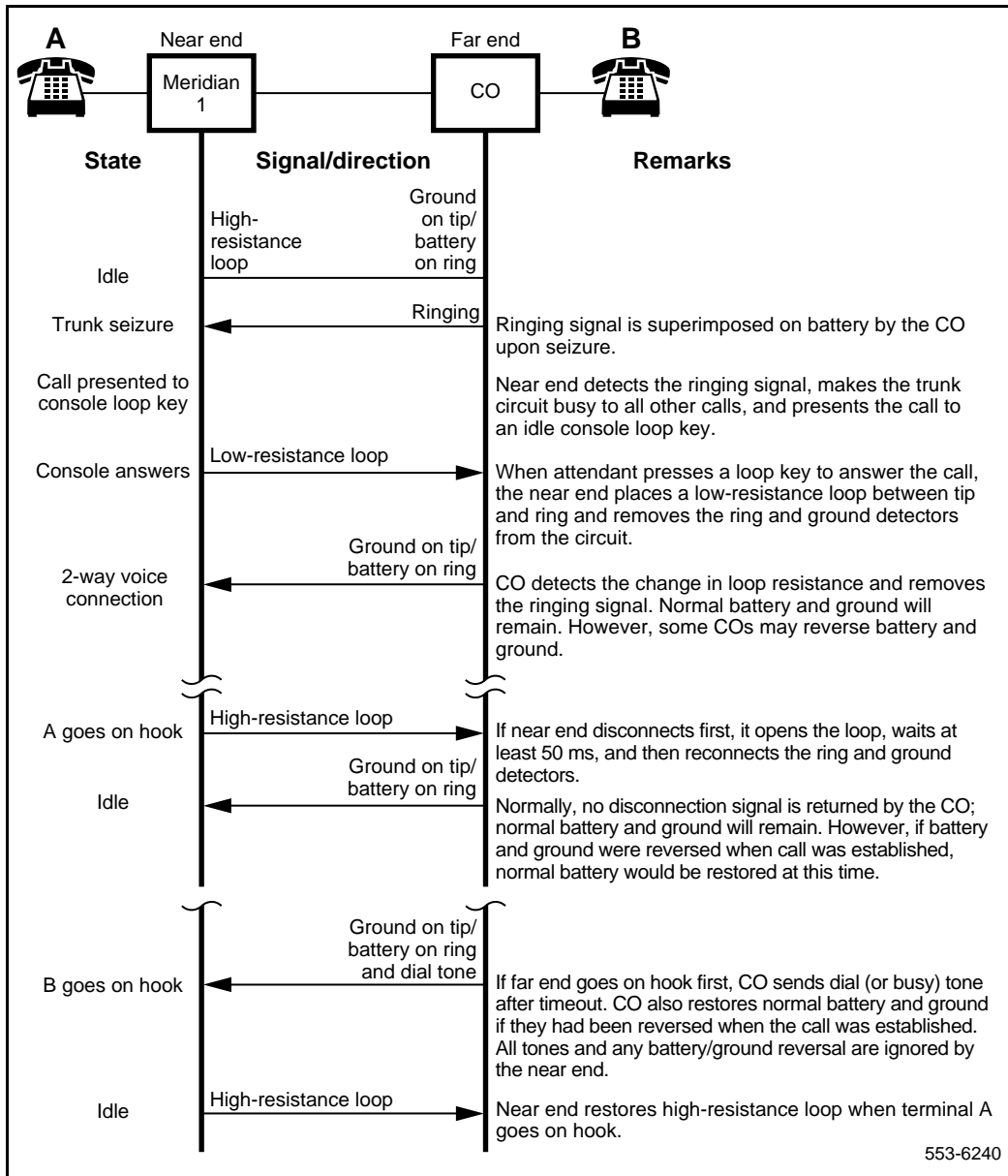
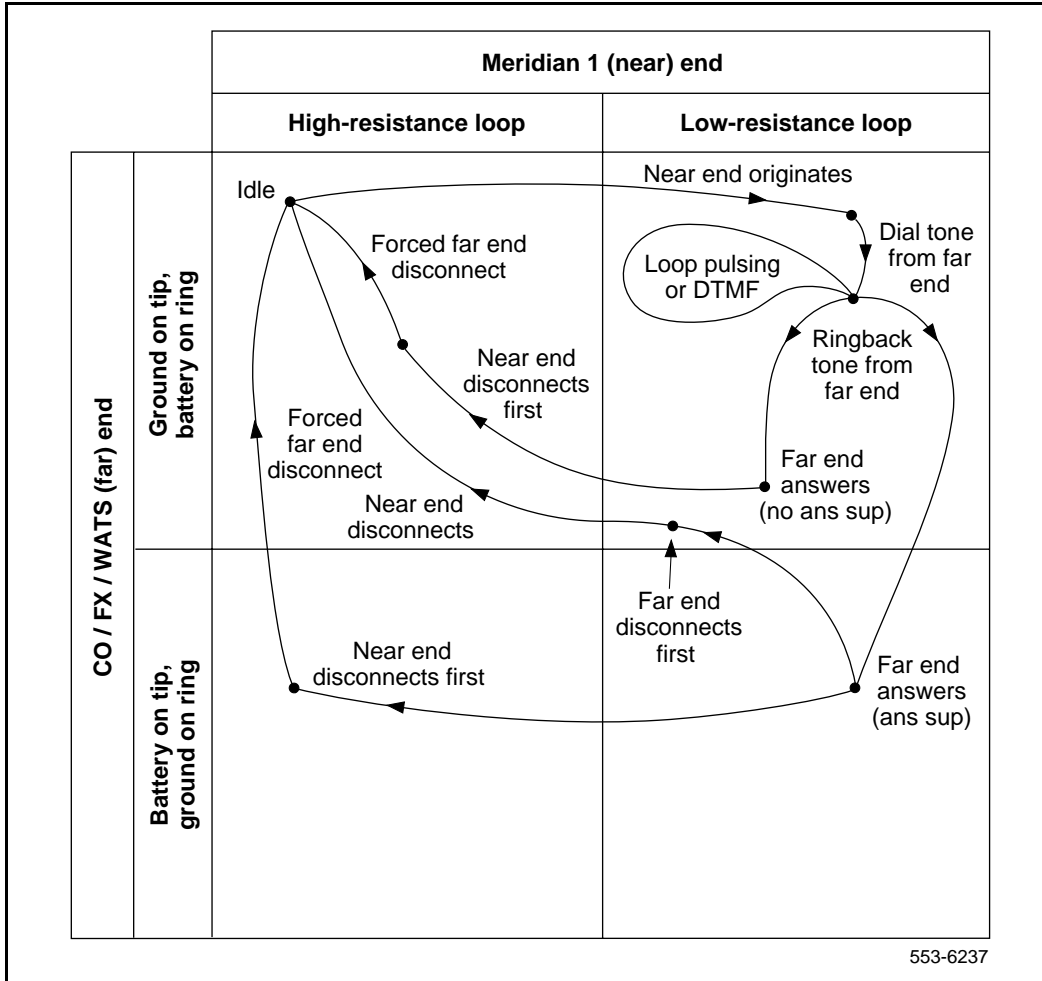
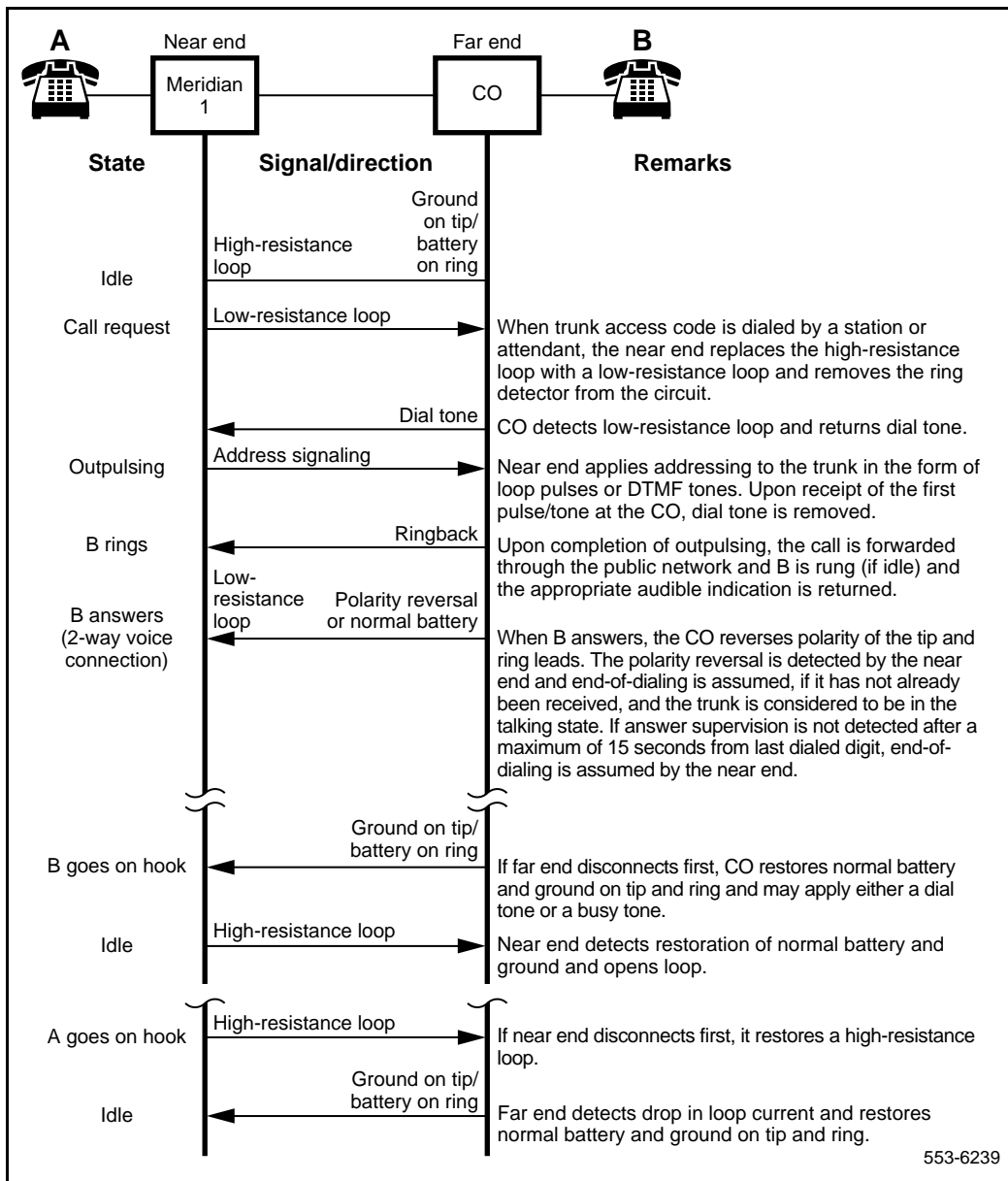


Figure 10  
 Loop start call states – outgoing call to CO/FX/WATS



**Figure 11**  
**Loop start call connection sequence – outgoing call to CO/FX/WATS**



## Ground start operation

Ground start operation is configured in software and implemented through software download messages. In the idle state, the tip conductor from the CO is open and a high-resistance negative battery is present on the ring lead.

### Incoming calls

In an incoming call, after ground is detected on the tip, the universal trunk card scans for a ringing detection signal before presenting the call to an attendant and tripping the ringing. When the attendant answers, a low resistance is placed across the tip and ring conductors, which trips CO ringing and establishes a speech path.

See Figure 12 on page 37 and Figure 13 on page 38.

### Reverse-wiring compensation

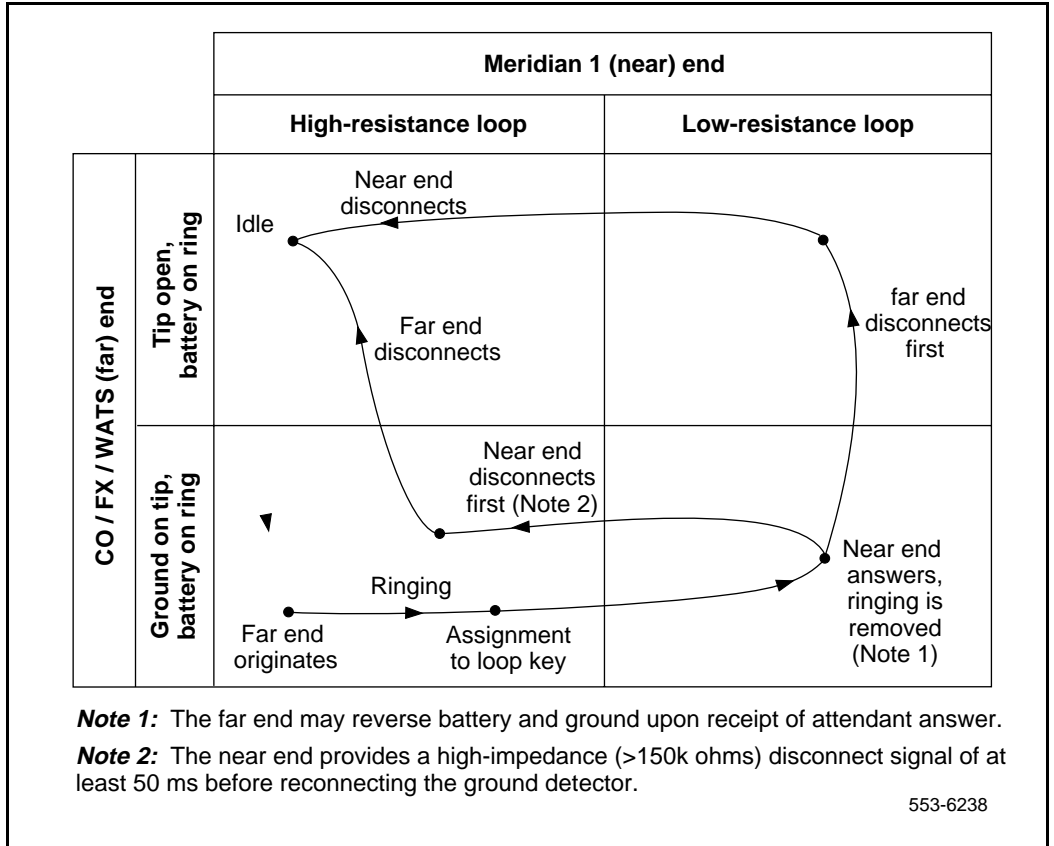
The Meridian 1 software includes a feature for detecting reverse wiring (connection of near-end tip and ring leads to far-end ring and tip leads, respectively) on ground start trunks with far-end answer supervision.

Ordinarily, an incoming call on a reverse-wired trunk without reverse-wiring compensation will present ringing on the tip lead rather than on the ring lead. Since software expects to see a ground on the tip lead, it will interpret the end of the first ringing signal as a switchhook flash. But since the interval between ringing signals exceeds the switchhook flash time of 512 milliseconds, software assumes far-end disconnect. This causes the call to be presented to a console loop key and then immediately removed.

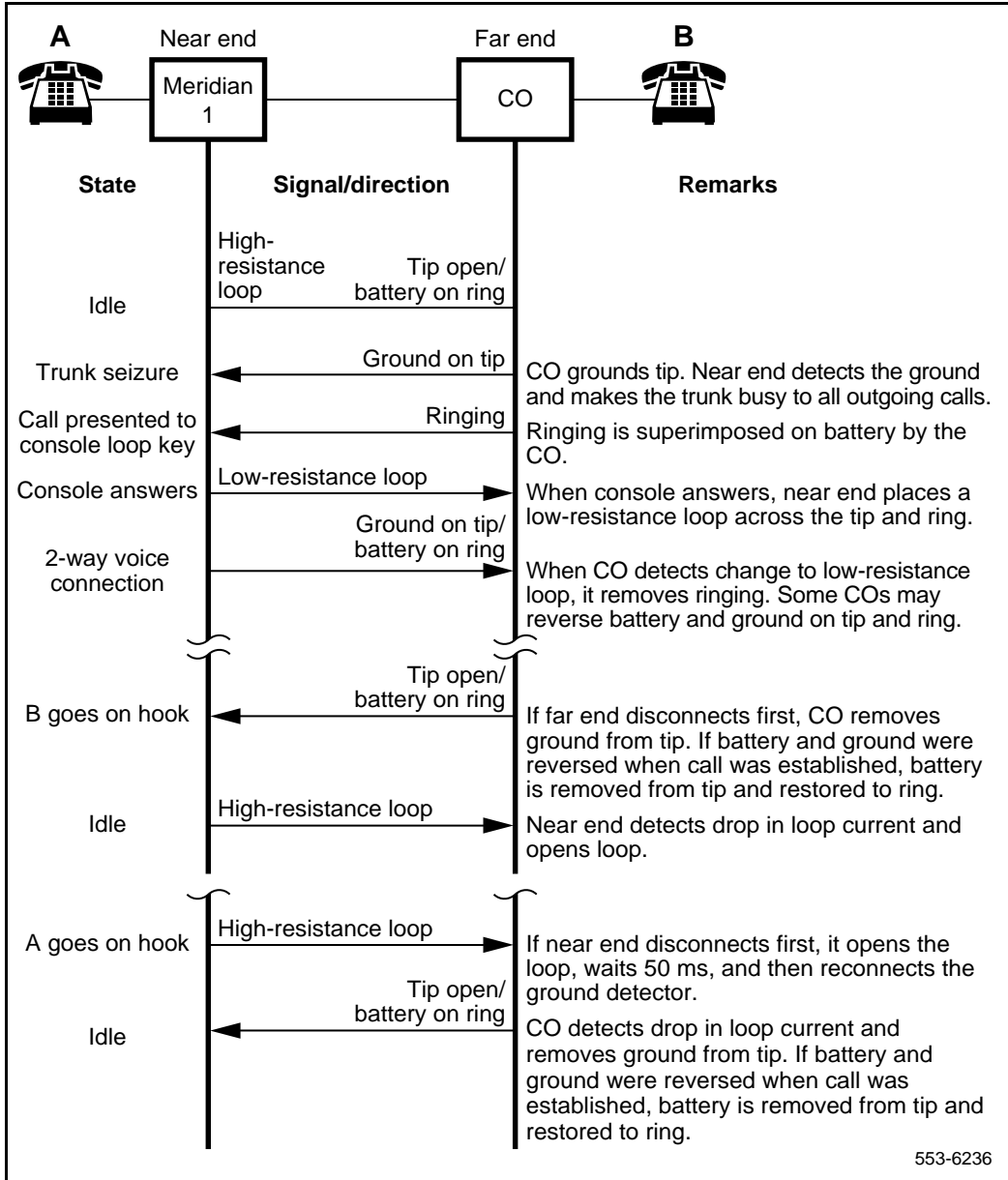
The reverse-wiring compensation feature operates as follows. If an apparent disconnect takes place immediately after the first ringing signal, the software will time stamp the event and temporarily remove the call from the console loop key.

If another such ringing/disconnect event occurs during the No Ringing Detector (NRD) time, the trunk will be considered “*possibly* reverse wired” and a threshold counter will be incremented. Calls on trunks identified as possibly reverse wired will be presented to the attendant during the initial ring, removed, and then continuously presented after the second ring. If a call on a possibly reverse-wired trunk is abandoned before the attendant answers, it will be disconnected after the NRD timer expires.

Figure 12  
Ground start call states – incoming call from CO/FX/WATS



**Figure 13**  
**Ground start call connection sequence – incoming call from CO/FX/WATS**



Trunks identified as possibly reverse wired will be switched by software to loop start processing after the second ring. This switching takes place on a call-by-call basis. Thus, if a previously correctly wired trunk becomes reverse wired, the next incoming call will be marked as possibly reverse wired and the threshold count will begin.

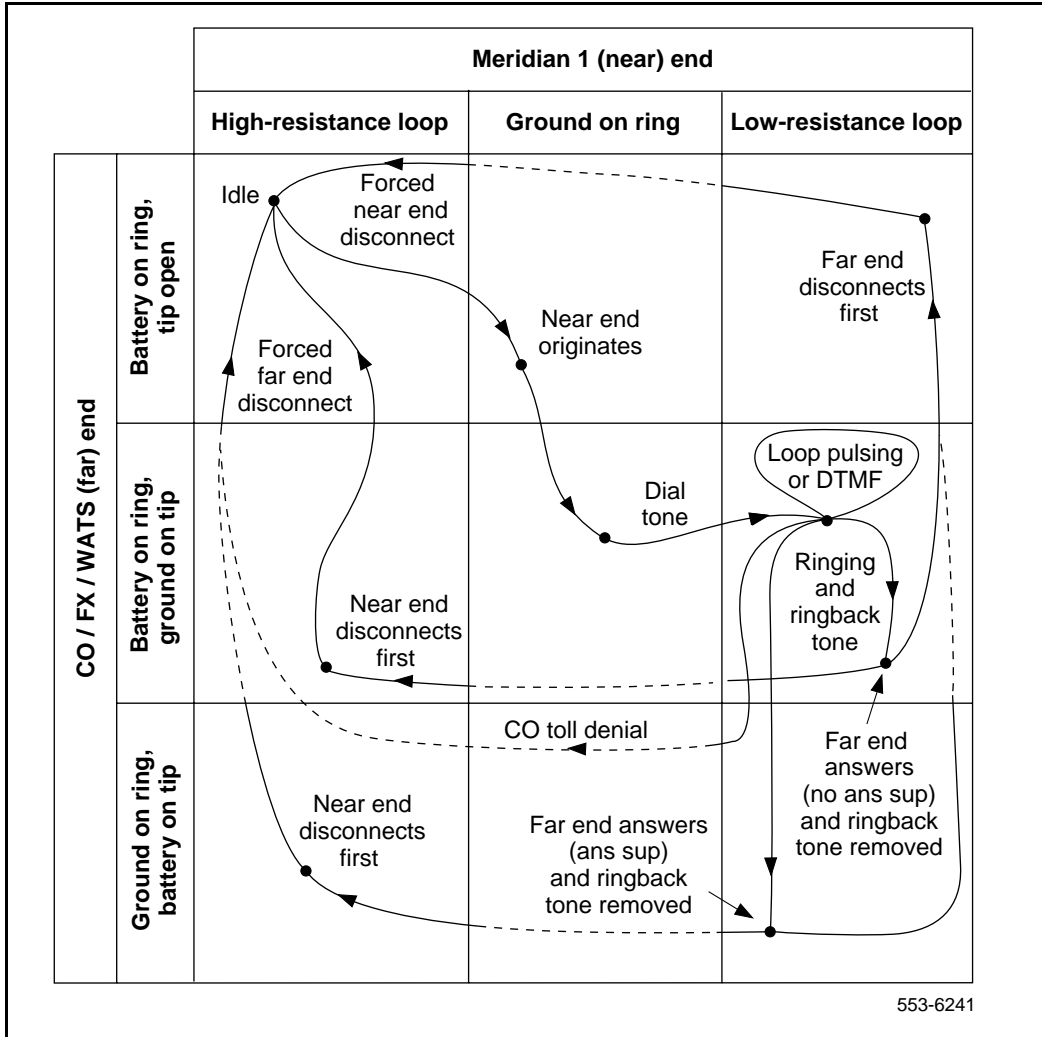
If the threshold count exceeds its limit, an error message is printed and the trunk is registered as “*positively* reverse wired.” Once identified as positively reverse wired, the call will be presented continuously from the first ring. When a reverse-wired trunk becomes correctly wired, the first subsequent call will clear the threshold counter and normal ground start processing will be implemented.

### **Outgoing calls**

For outgoing calls, the trunk provides ground to the ring lead. The CO responds by grounding the tip and returning dial tone. After the tip ground is detected by the card, a low-resistance path is placed between the tip and ring leads and the ground is removed from the ring. Addressing is then applied from the Meridian 1 in the form of loop (interrupting) dial pulses or DTMF tones. See Figure 14 on page 40 and Figure 15 on page 41.

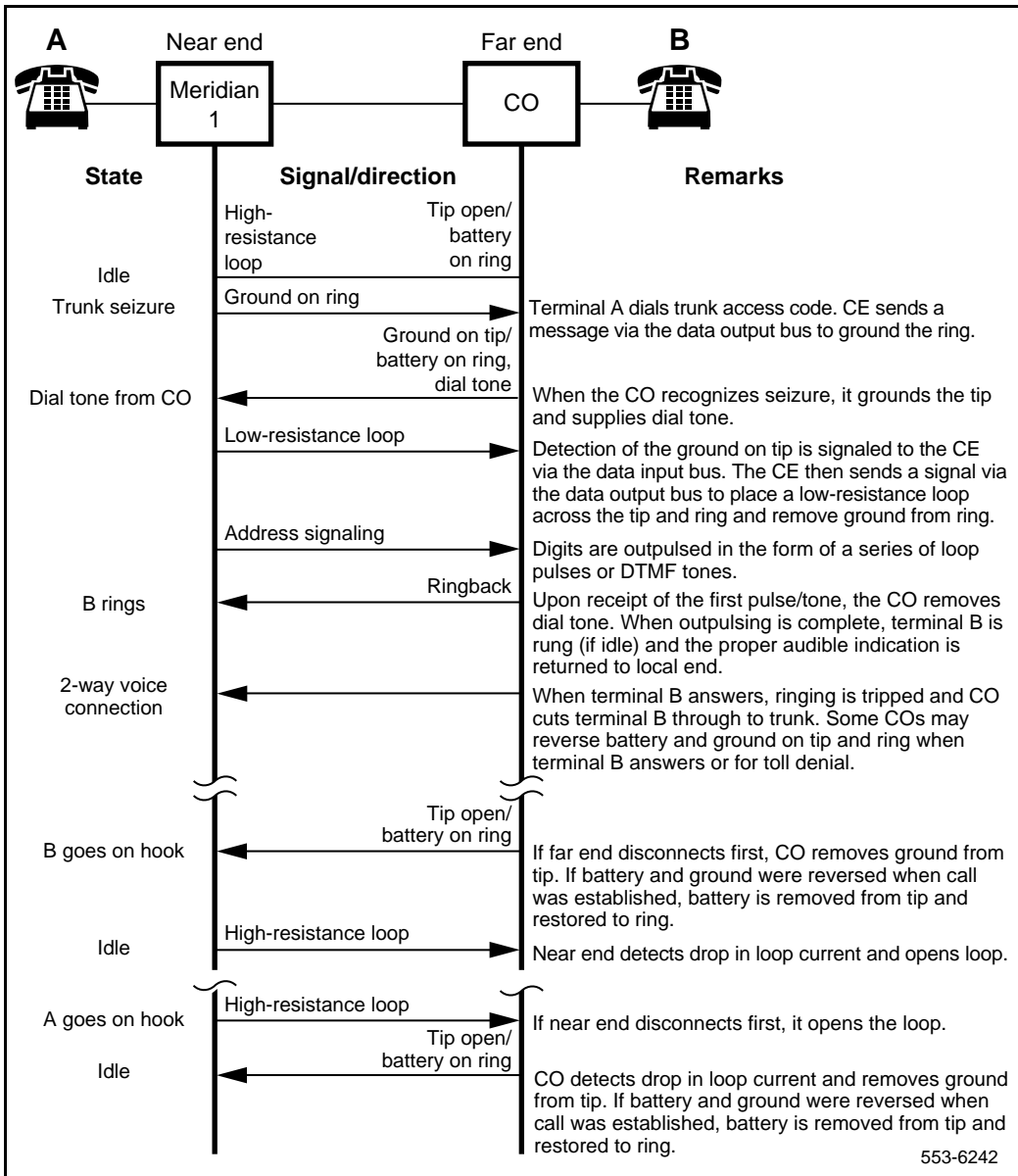
The Polarity-Sensitive/Polarity-Insensitive Packs (PSP and PIP) feature must be set to provide for proper outgoing call-duration recording with ground start operation. Refer to the description of loop start operation on page 31 for a more complete discussion of PSP and PIP.

Figure 14  
Ground start call states – outgoing call to CO/FX/WATS





**Figure 15**  
**Ground start call connection sequence – outgoing call to CO/FX/WATS**



## Direct inward dial operation

### Incoming calls

An incoming call from the CO places a low-resistance loop across the tip and ring leads. See Figure 16 on page 43 and Figure 17 on page 44.

Dial pulses or DTMF tones are then presented from the CO. When the called party answers, the universal trunk card reverses battery and ground on the tip and ring leads to the CO. The trunk is arranged for first party release. The CO releases the trunk by removing the low-resistance loop, at which time normal battery and ground are restored at the near-end. The operation represented in Figures 16 and 17 also applies to incoming TIE trunk calls from a far-end PBX.

*Note:* The near-end can be configured for immediate start, delay dial, or wink start.

## Two-way, loop dial repeating, TIE trunk operation

### Incoming calls

In an incoming call configuration, the far-end initiates a call by placing a low-resistance loop across the tip and ring leads. See Figure 18 on page 45 and Figure 19 on page 46.

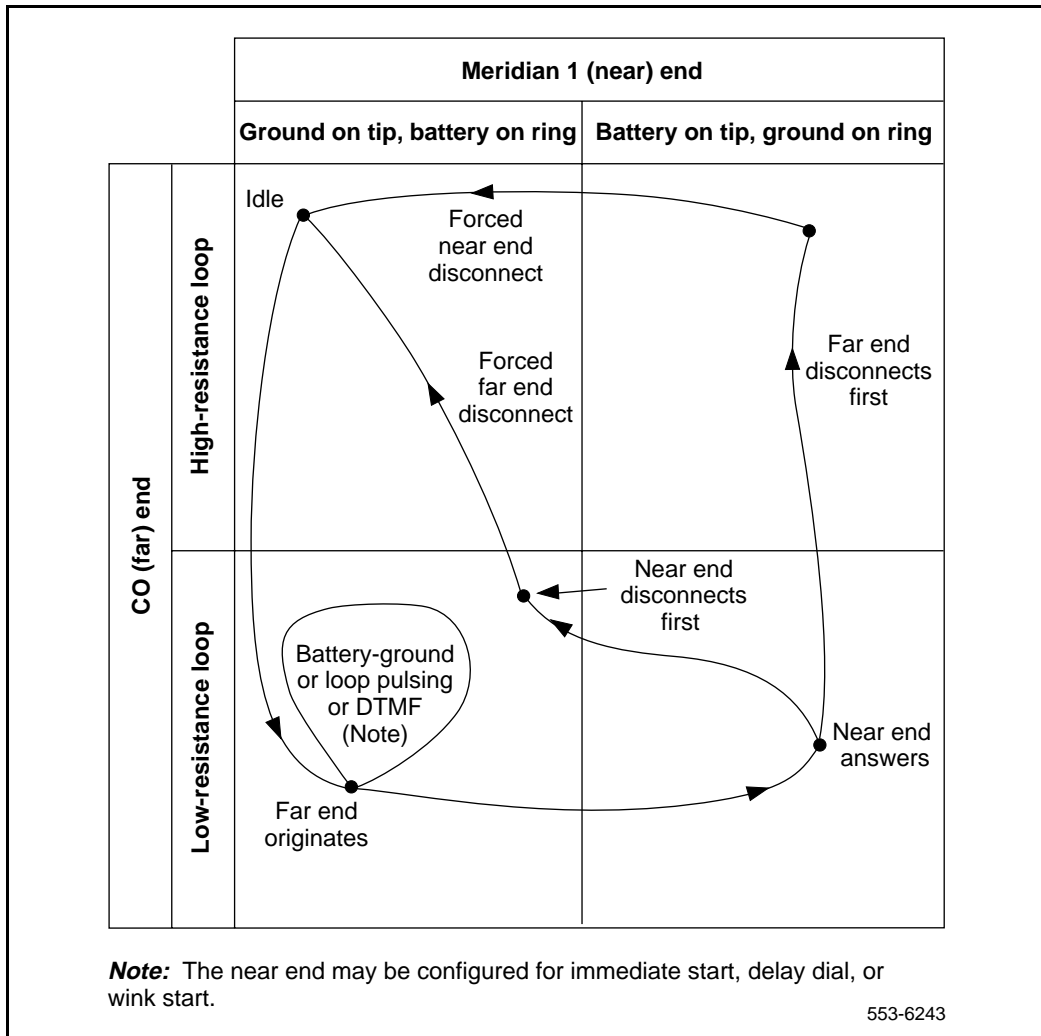
This causes a current to flow through the battery feed resistors in the trunk circuit. Address signaling is then applied by the far-end in the form of DTMF tones or dial pulses. When the called party answers, an answer supervision signal is sent by software, causing the Meridian 1 to reverse battery and ground on tip and ring to the far-end. Far-end disconnect is initiated by opening the loop while near-end disconnect is initiated by restoring normal battery and ground. The operation represented in Figures 18 and 19 also applies to incoming DID trunk calls from a CO.

*Note:* Where no near-end answer supervision is provided, the party at the far-end hangs up, after recognizing near-end call termination.

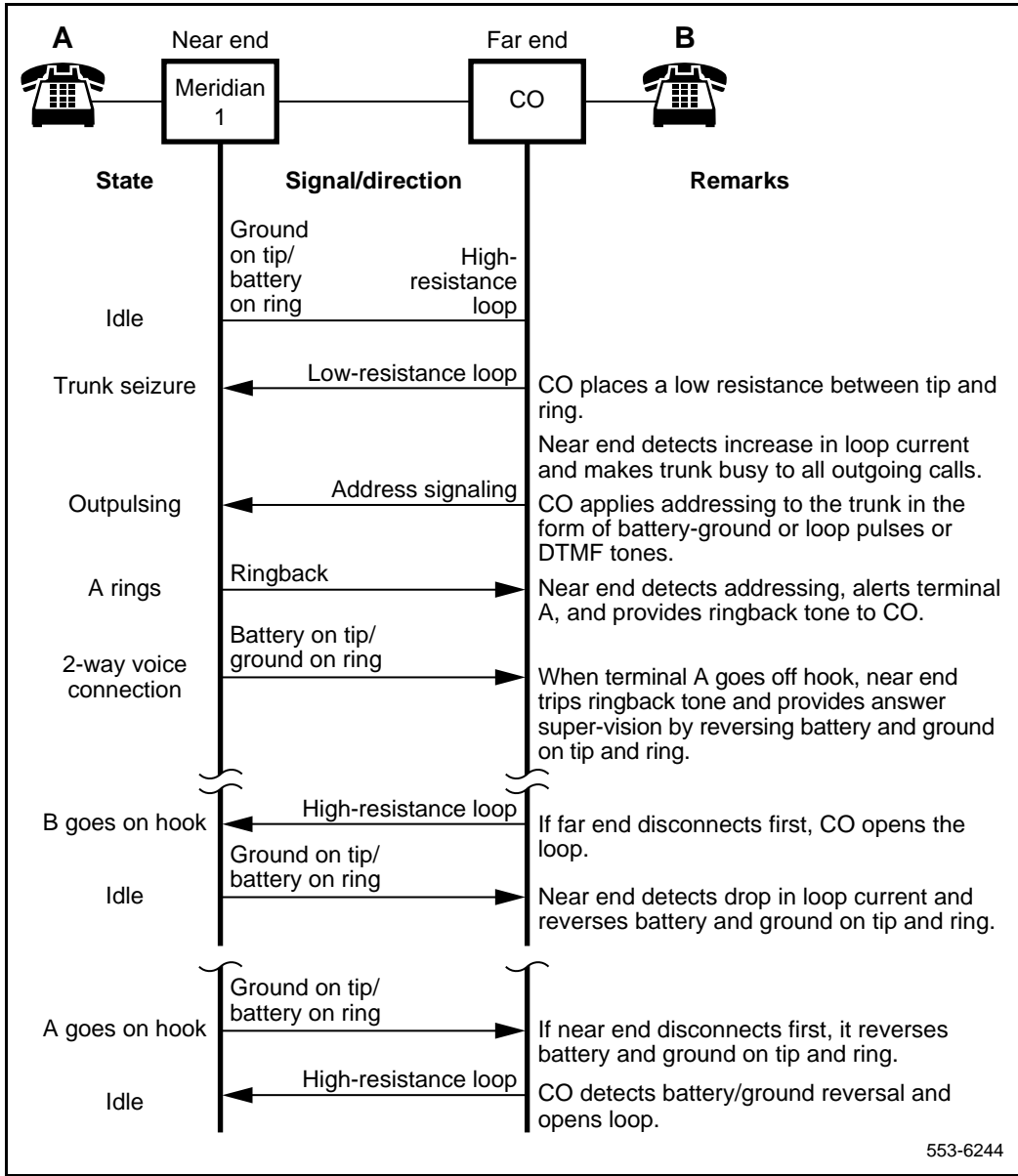
### Outgoing calls

In an outgoing call configuration, the universal trunk card is connected to another PBX by a TIE trunk. See Figure 20 on page 48 and Figure 21 on page 49.

Figure 16  
 DID trunk, loop DR call states – incoming call from CO

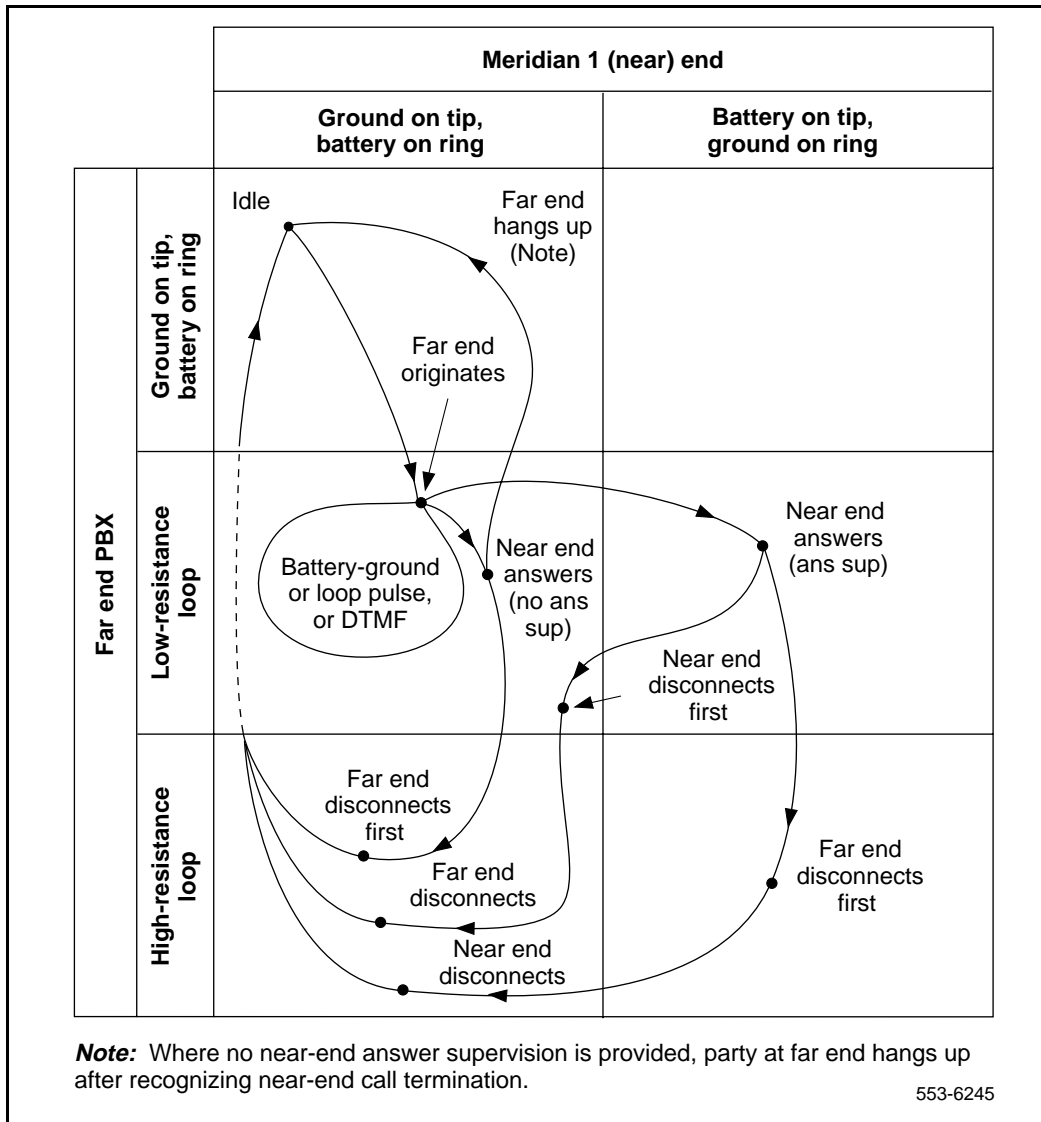


**Figure 17**  
**DID trunk, loop DR call connection sequence – incoming call from CO**

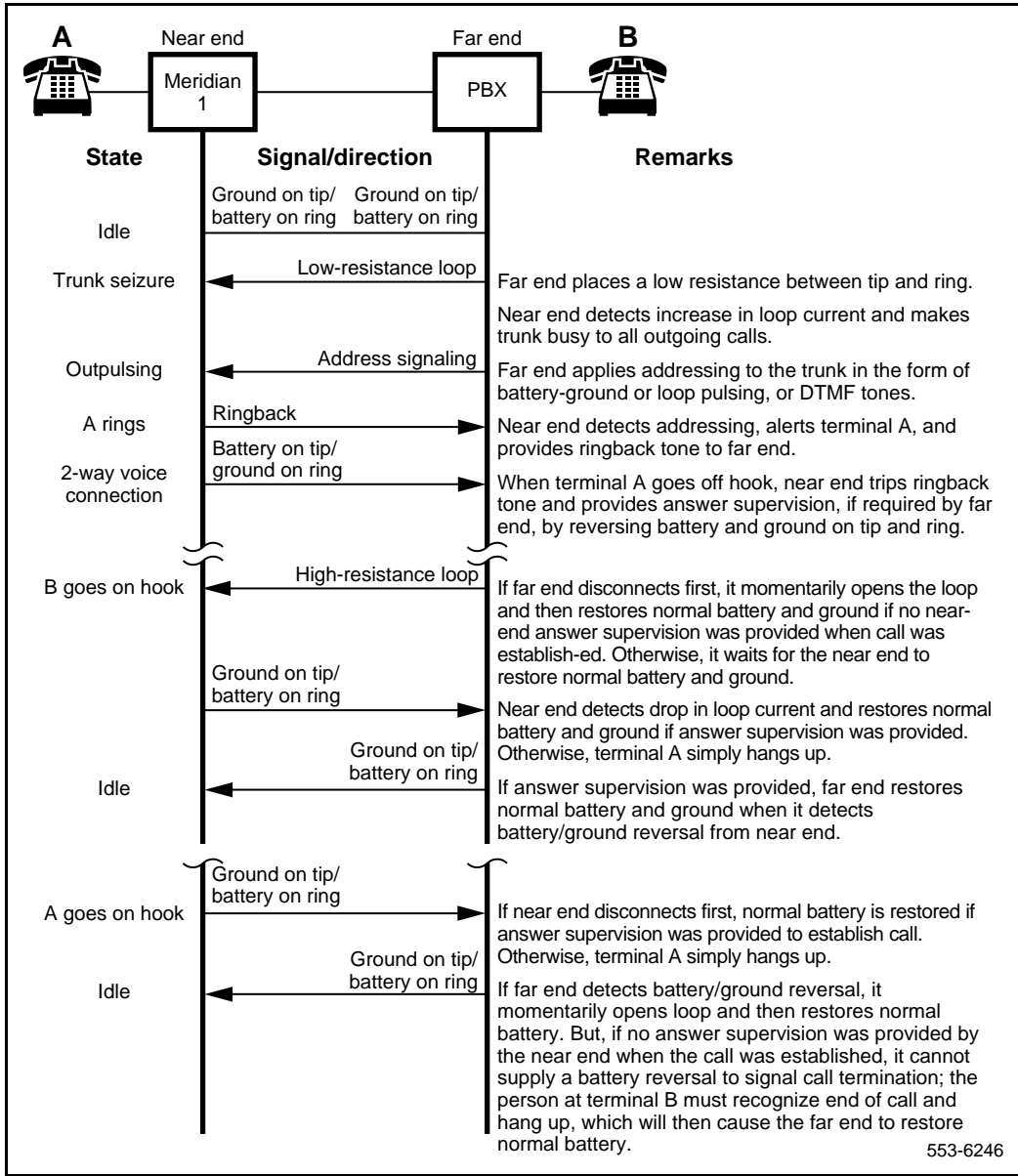


553-6244

**Figure 18**  
**Two-way, loop DR, TIE trunk call states – incoming call from far-end PBX**



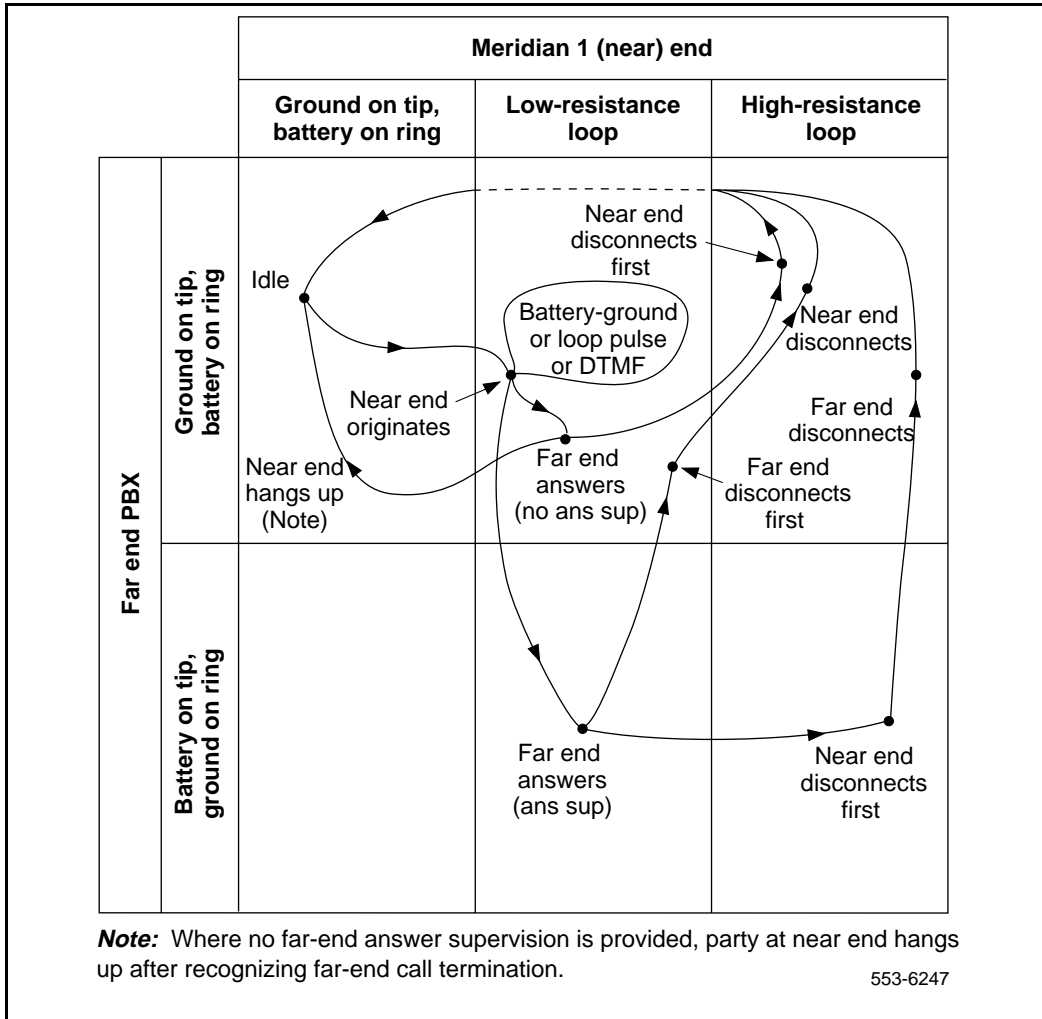
**Figure 19**  
**Two-way, loop DR, TIE trunk call connection sequence – incoming call from far-end PBX**



An outgoing call from the near-end seizes the trunk facility by placing a low-resistance loop across the tip and ring leads. Outward addressing is then applied from the Meridian 1 in the form of DTMF tones or dial pulses. If answer supervision is provided by the far-end, reverse battery and ground on tip and ring is returned. The operation represented in Figures 20 and 21 also applies to outgoing calls on a DID trunk.

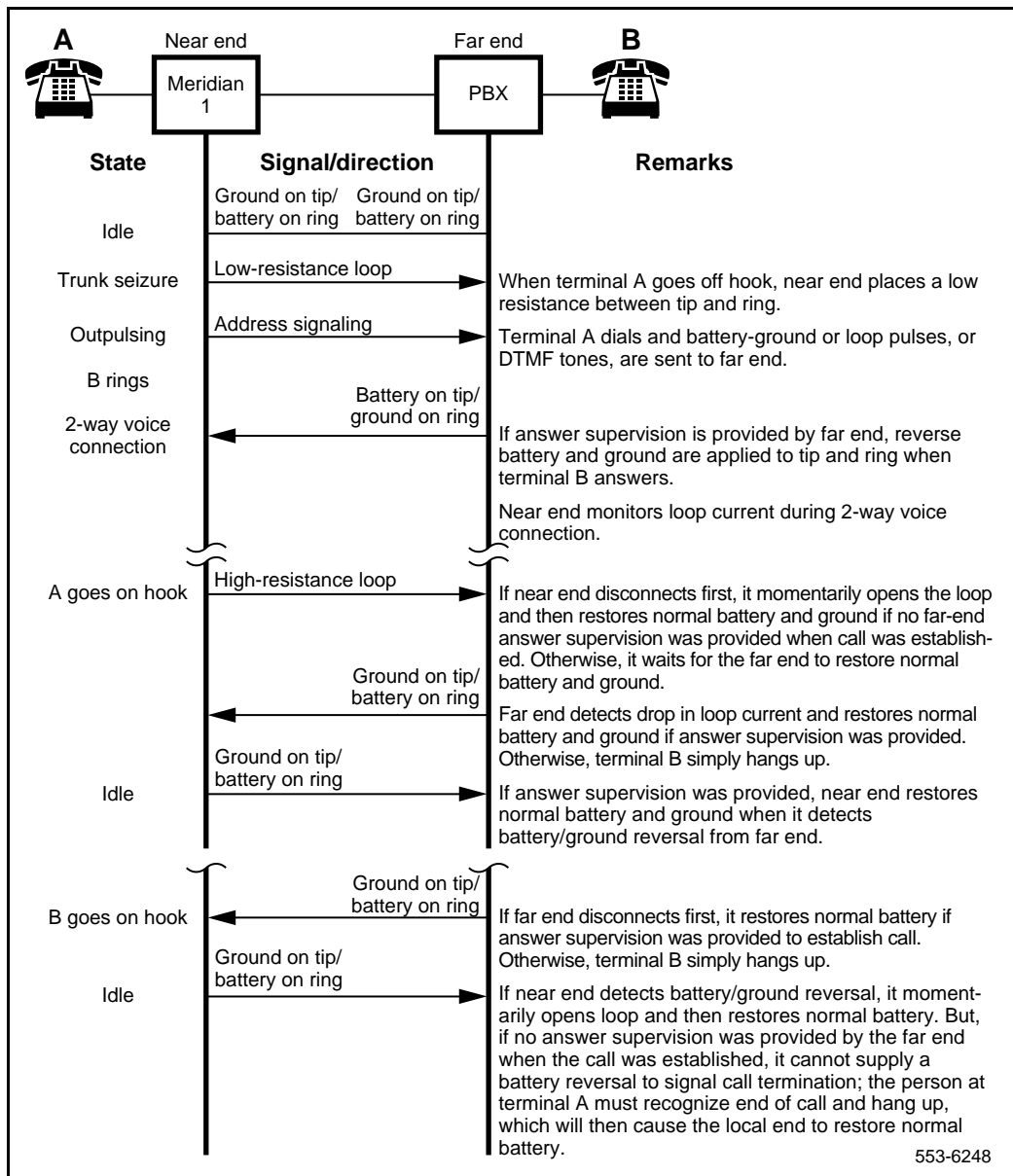
**Note:** Where no far-end answer supervision is provided, the party at the near-end hangs up, after recognizing far-end call termination.

Figure 20  
Two-way, loop DR, TIE trunk call states – outgoing call to far-end PBX





**Figure 21**  
**Two-way, loop DR, TIE trunk call connection sequence – outgoing call to far-end PBX**



## Senderized operation for DID and two-way loop DR trunks

### Incoming calls

If the far-end is senderized, the near-end can be operated in any mode: immediate start (IMM), delay dial (DDL) or wink (WNK) start, as assigned at the STRI prompt in the Trunk Administration program LD 14.

See Figure 22 on page 51.

**Note:** If a ground start trunk, the outpulse towards the office occurs after ground detection. If a loop start trunk, the outpulse toward the office occurs one second later.

For immediate start, following the seizure signal, the far-end may start pulsing after the standard delay (normally 65 ms, minimum).

For delay dial or wink start modes, stop/go signaling (off hook/on hook or battery/ground reversal) is returned by the Meridian 1 after receipt of the seizure signal. The delay dial (stop) signal begins immediately upon seizure and ends (go signal) 384 ms later. The wink start (stop) signal begins 384 ms after seizure and ends (go signal) 256 ms later. The far-end detecting the go signal may start pulsing after the standard delay (normally 55 ms, minimum). Stop/go signaling, in addition to the signaling function, serves as an integrity check to help identify a malfunctioning trunk.

If required, the near-end can be configured to provide pseudo-answer supervision at expiration of the end-of-dial timer. End-of-dial timer settings are made at the EOD (non-DTMF) or ODT (DTMF) prompts in the Trunk Route Administration program LD 16.

The operation represented in Figure 22 also applies to incoming calls on a DID trunk from a CO.

### Outgoing calls

When DDL or WNK mode is used, outgoing calls require a stop/go signal from the far-end so that the near-end cannot outpulse until the far-end is ready to receive digits. See Figure 23 on page 52.

**Note:** Pseudo-answer supervision is provided at the near-end at expiration of end-of-dial timer. Where no far-end answer supervision is provided, the party at the far-end hangs up, after recognizing near-end call termination.

**Figure 22**  
**Two-way, loop DR, TIE trunk call states – incoming call through senderized, tandem PBX from a CO/FX/WATS trunk**

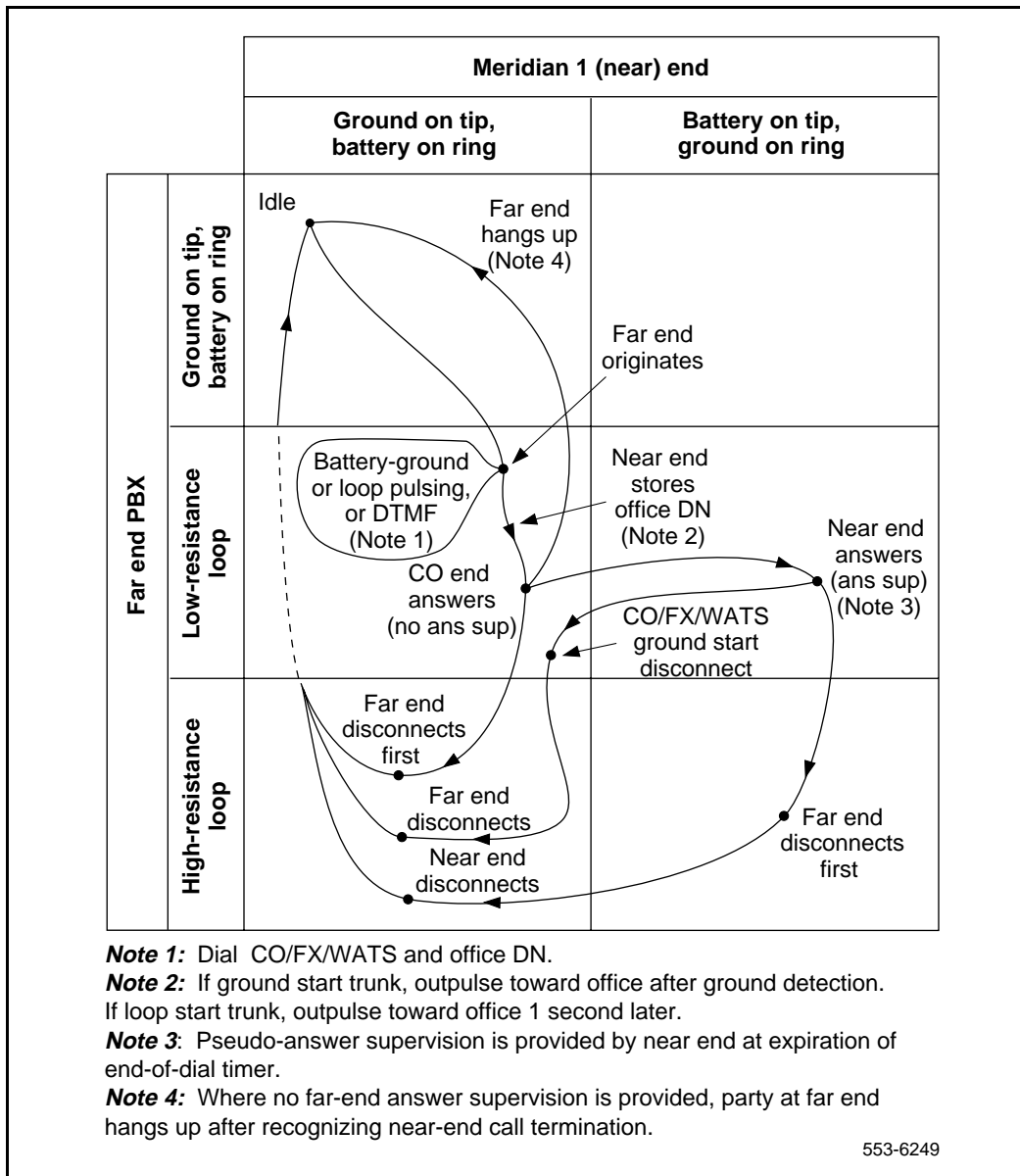
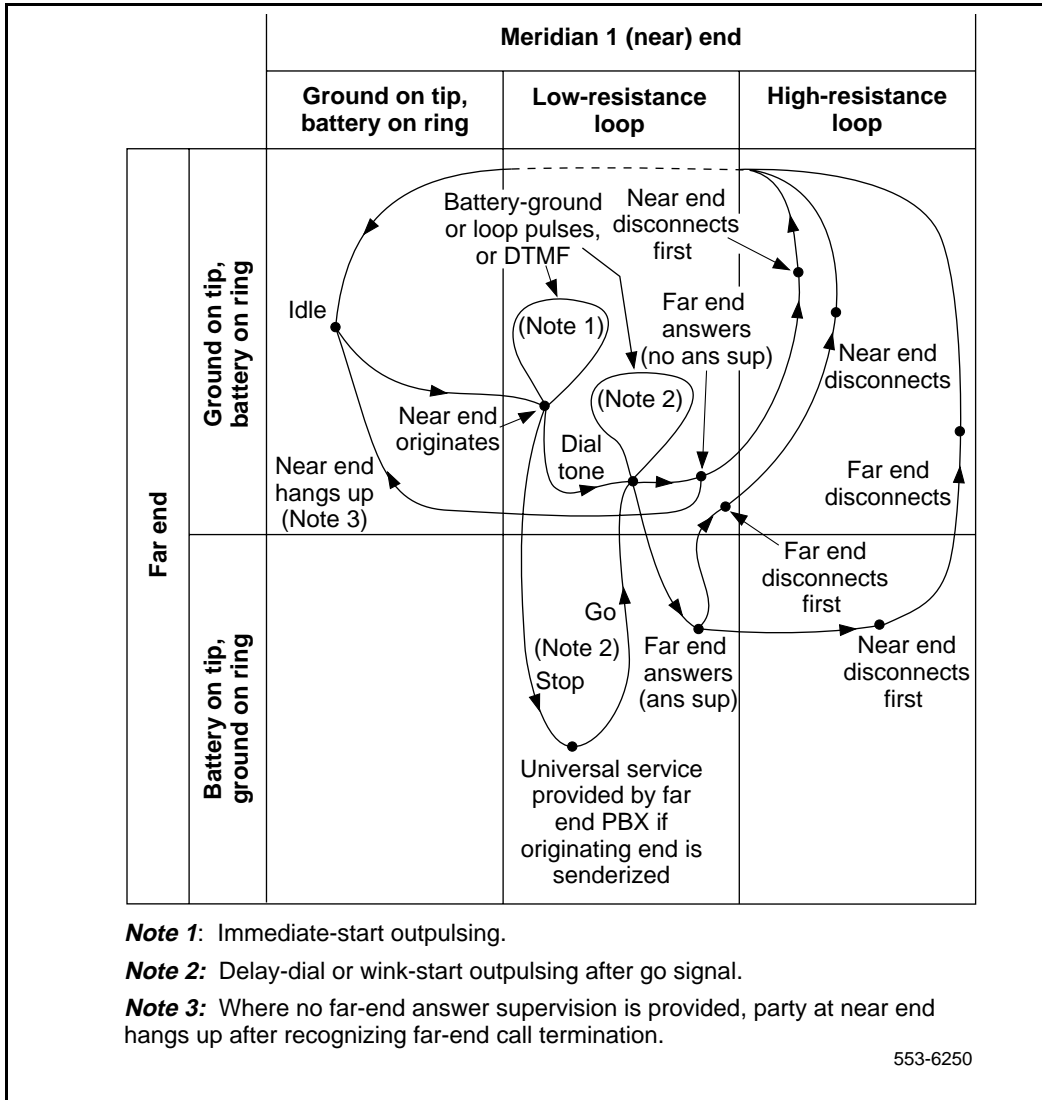


Figure 23  
Two-way, loop DR, TIE trunk call states – outgoing call through far-end PBX to CO/FX/WATS



## **Outgoing automatic, incoming dial operation**

### **Incoming calls**

When the universal trunk card is seized by the far-end on an incoming call, a low-resistance loop is placed across the tip and ring leads. Addressing is then sent by the far-end in the form of battery-ground or loop pulses, or DTMF tones. The trunk is released at the far-end when the loop is opened. When the near-end detects an open loop, it returns to a normal state.

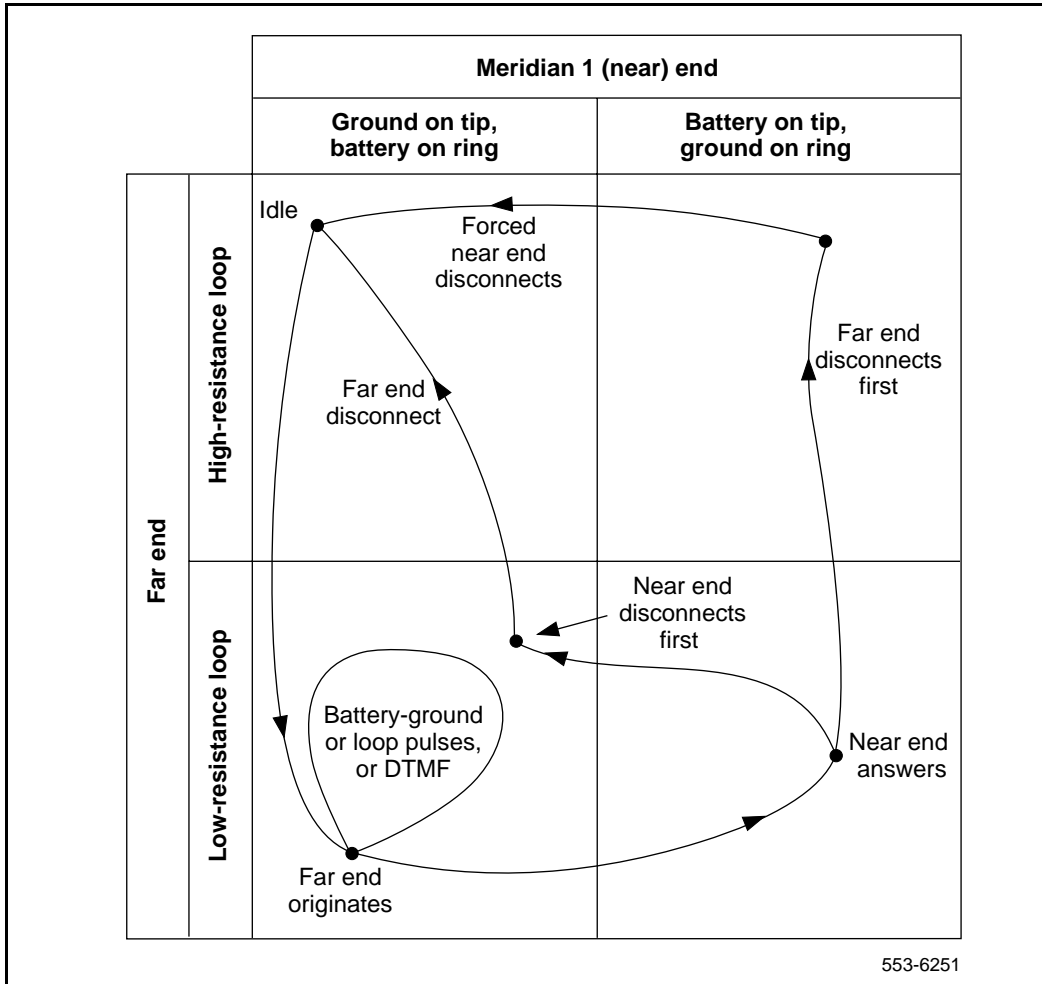
See Figure 24 on page 54 and Figure 25 on page 55.

### **Outgoing calls**

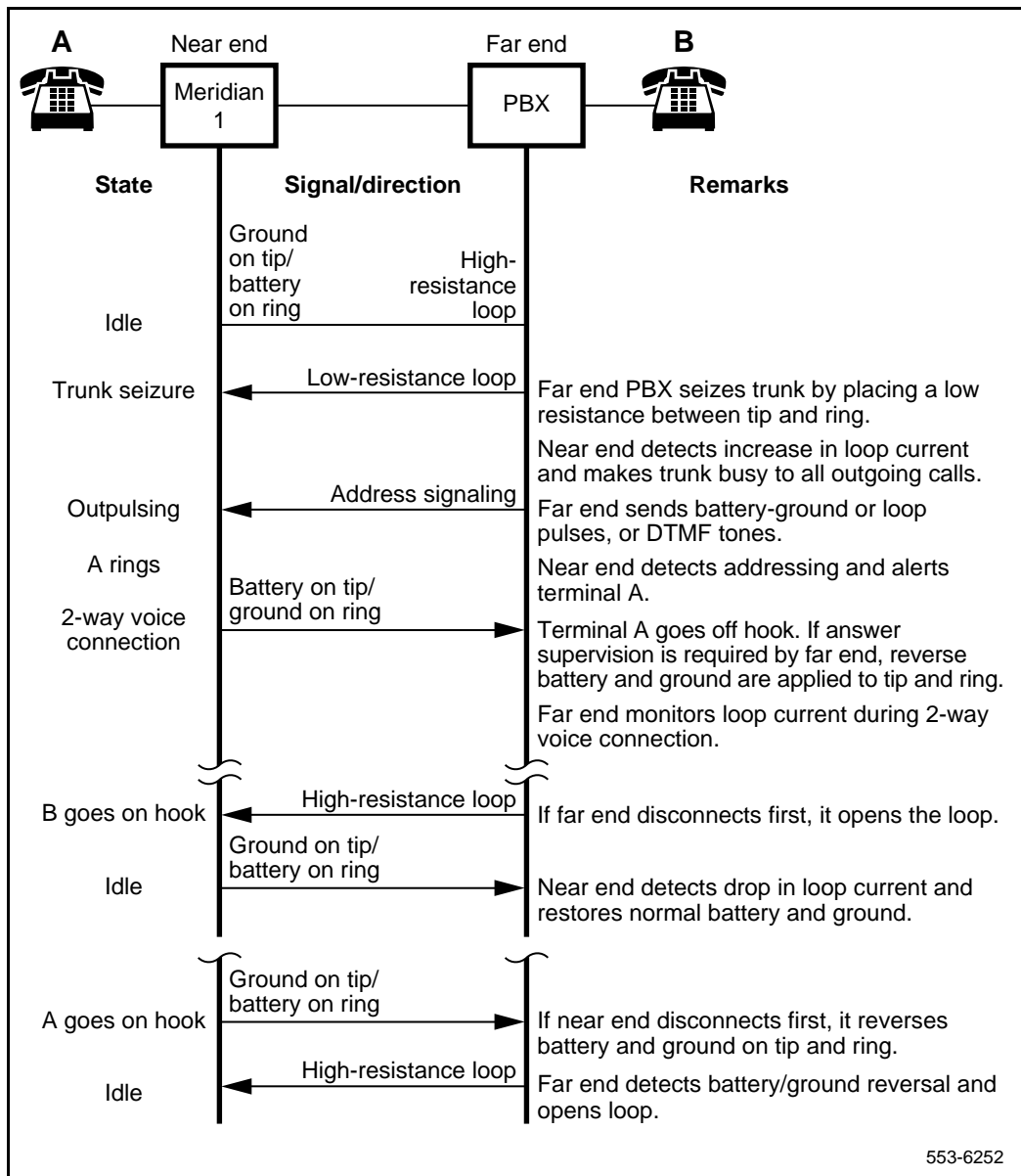
When seized as a dial-selected outgoing trunk, the near-end places battery on the tip and ground on the ring. This alerts the far-end of the seizure. The far-end responds with a low resistance across the tip and ring leads.

See Figure 26 on page 56 and Figure 27 on page 57.

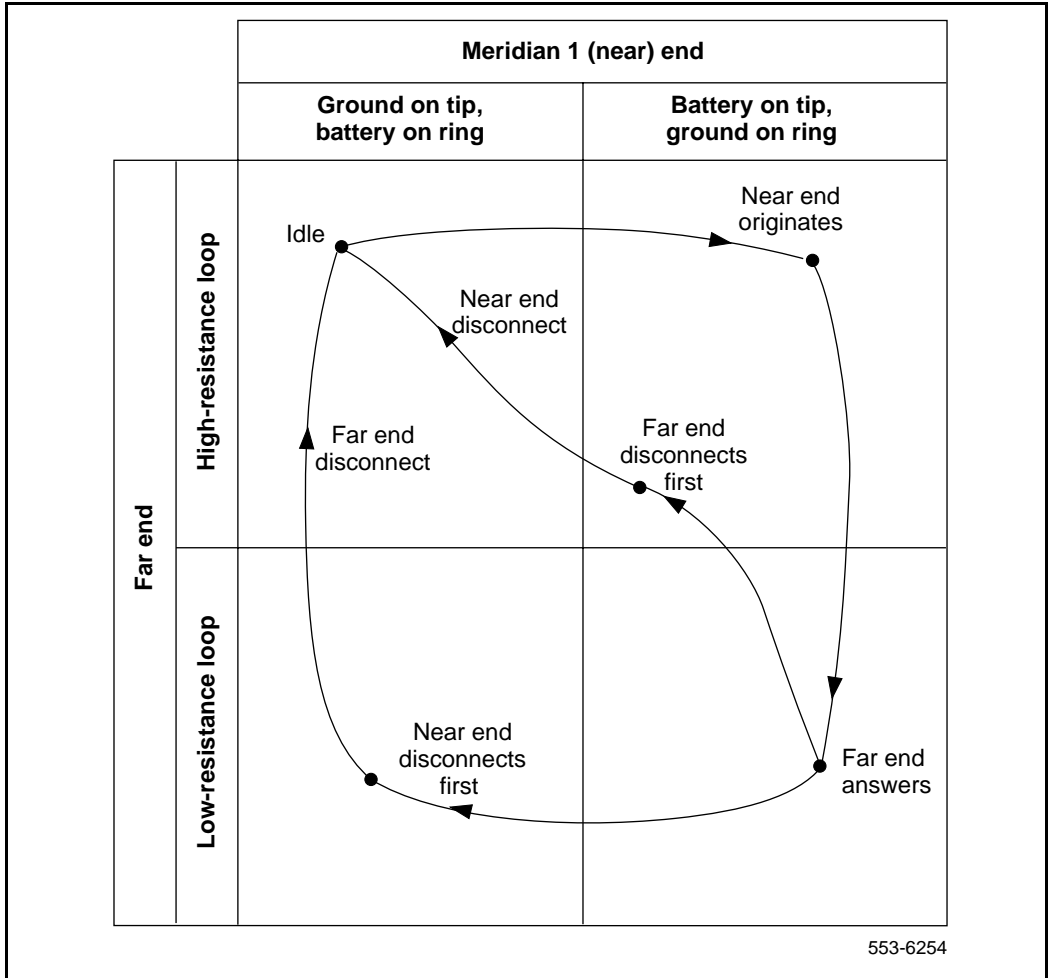
Figure 24  
Two-way, loop OAID, TIE trunk call states – incoming call from far-end PBX



**Figure 25**  
**Two-way, loop OAID, TIE trunk call connection sequence – incoming call from far-end PBX**

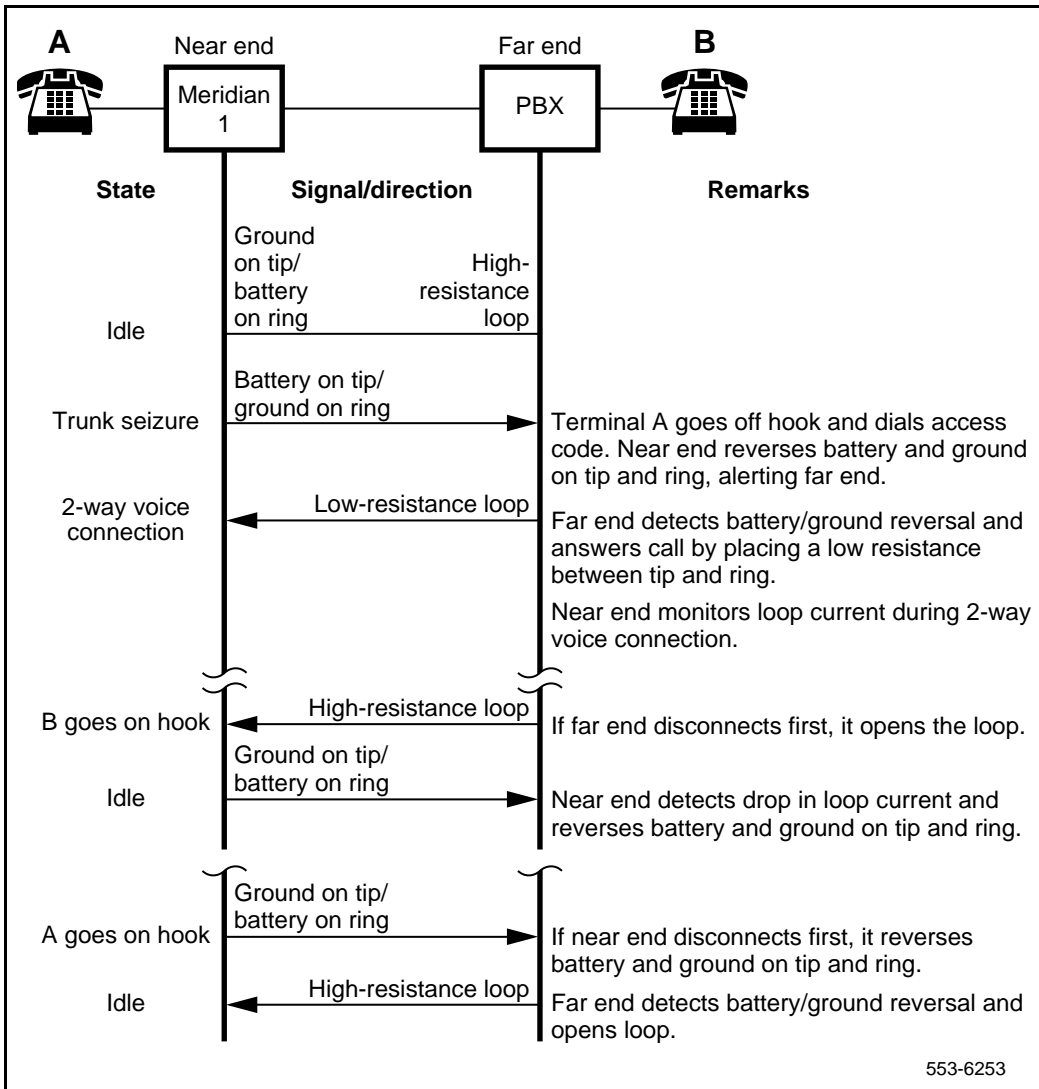


**Figure 26**  
**Two-way, loop OAID, TIE trunk call states – outgoing call to far-end PBX**





**Figure 27**  
**Two-way, loop OAID, TIE trunk call connection sequence – outgoing call to far-end PBX**



## Recorded announcement trunk operation

**Note:** Refer to “Multi-Channel RAN modes” on page 61 for information on Multi-Channel RAN modes, which are not linked to a RAN machine or a given trunk.

When configured for Recorded Announcement (RAN) operation, a trunk unit is connected to a customer-provided-recorded announcement machine. Announcement machines must be compatible with Meridian 1 RAN trunks. Use the manufacturer’s instructions to set up the Announcement machines.

Each trunk unit provides the following for operation with RAN equipment:

- pulse start, level start, or continuous operation modes
- selectable termination of tip and ring leads into 600 or 900 ohms for interface with a low-impedance (2- or 4-ohm) source
- connection of up to 24 trunk units to a single announcement machine channel

### Recorded announcement machines

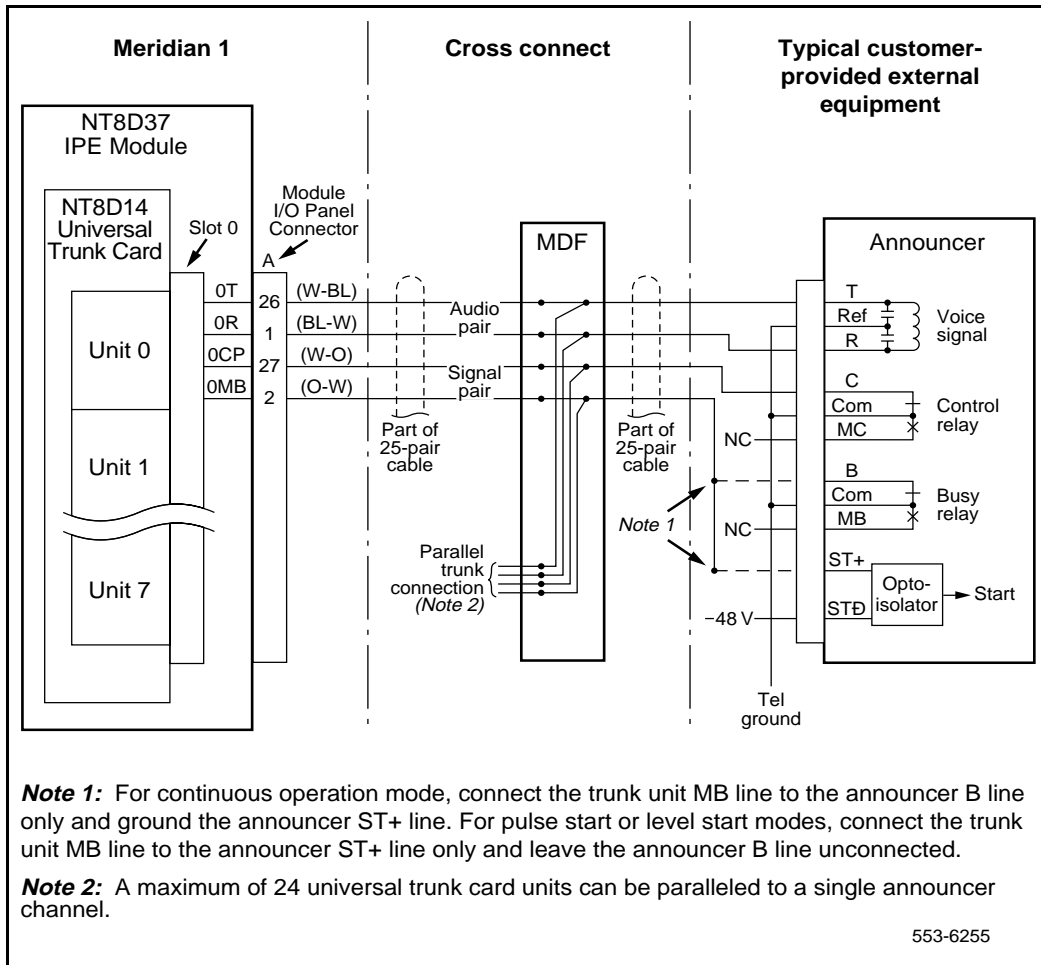
Recorded announcement machines store prerecorded voice messages that are played back to the trunk units to which they are connected. Most commercially available announcement machines store recordings digitally, although some drum and tape units are still in service.

An announcement machine can provide one or more channels and each channel can be prerecorded with a different message. Some announcement machines also provide a Special Information Tone (SIT) capability. These tones are inserted at the beginning of intercept messages (such as “Your call cannot be completed as dialed. Please check the number and try again.”).

Figure 28 on page 59 shows a typical connection from a single announcement machine channel to unit 0 on a universal trunk card installed in slot 0 in an NT8D37 IPE Module.

See *System Installation Procedures* (553-3001-210) for trunk wiring information.

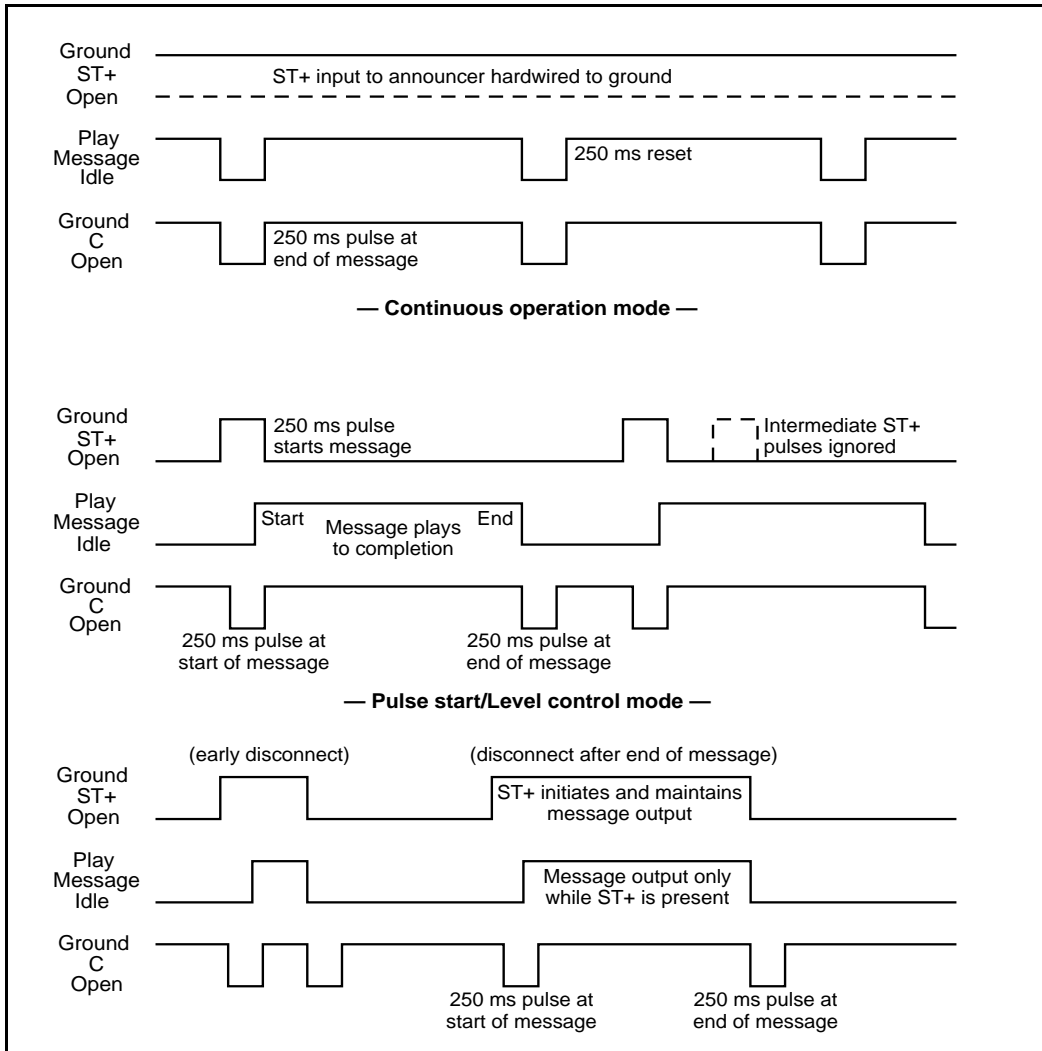
**Figure 28**  
**Connecting RAN equipment to the NT8D14 Universal Trunk Card (typical)**



### RAN modes of operation

Figure 29 shows the relationship of control signals to message playback for the operating modes available in announcement machines. The signal names shown in the figure are typical.

**Figure 29**  
**RAN control signals (Control GRD = IDLE)**



**Note 1:** For continuous operation mode, connect the trunk unit MB line to the announcer B line only, and ground the announcer ST+ line. For pulse start or level start modes, connect the trunk unit MB line to the announcer ST+ line only, and leave the announcer B line unconnected.

**Note 2:** A maximum of 24 universal trunk card units can be paralleled to a single announcer channel.

### **Multi-Channel RAN modes**

In Multi-Channel RAN, multiple RAN channels can be configured within one RAN trunk route. In a Multi-Channel RAN route, each trunk has its own dedicated RAN channel on a physical RAN machine. Multi-Channel RAN routes do not support the cross-connecting (daisy chains) of multiple trunk ports together so that several callers hear the same RAN message.

The new multi-channel machine types – continuous Mode Multi-Channel (MCON), Pulse Start/Stop Multi-Channel (MPUL) and Level Start/Stop Multi-Channel (MLVL) – are not linked to a RAN machine or a given trunk. All trunks belonging to the RAN route are considered independent. RAN trunks and RAN machine channels are connected one to one. If one RAN trunk is detected as faulty, then all other trunks are not impacted.

For these new RAN machine types, the maximum length of the recorded announcement is two hours. The meaning of a ground signal received from the RAN machine (play or idle) is configured in LD 16.

### **Multi-Channel Level Start/Control Mode (minimum vintage BA)**

A RAN mode of operation is available called “Multi-Channel Level Start/Control Mode.” This mode allows provisioning of multiple RAN channels for a RAN route (playing the same message independently on demand) cross-connected one-for-one to each RAN trunk in a multi-channel level start RAN route. Do not bridge RAN trunks in a multi-channel RAN route.

The Route Data Block LD 16 is used to configure a RAN route in Multi-Channel Level Start/Control mode, using the following response:

**RTYP = MLSS**

Trunk members are provisioned in the Trunk Data Block LD 14.

Refer to “Programming RAN trunks” on page 63 and to the *Software Input/Output Guide Administration* (553-3001-311) for more detailed instructions on service change programs.

### **Continuous operation mode**

In the continuous operation mode (sometimes called the Audichron mode), a message is constantly played, over and over again. Callers “barge in” on a playing message or are provided with a ringback tone until the message begins its next playing. The start line (ST+) is hardwired as always active. See Figure 29 on page 60. At the end of each message, a pulse is issued on the “C” line that is used by the trunk unit to cut through to the waiting call.

**Note:** The “B” (busy) signal line shown in Figure 28 on page 59 (not represented in Figure 29) is used to indicate availability of an announcement machine message to the trunk unit when configured for the continuous operation mode. This signal is made active (ground) by the announcement machine if the channel contains a recorded message and is in an online condition. The “B” line is not connected to a trunk unit when configured for start mode operation.

### **Start modes (minimum vintage BA)**

In a start mode (sometimes called the Code-a-Phone or start-stop mode), playback of a message does not begin until a start pulse is received by the announcement machine. Two subcategories of the start mode exist: pulse start and level start.

In the pulse start mode, a start pulse activates playback of a message that continues until completion. See Figure 29 on page 60. The announcement machine ignores all other start pulses that might occur until the message is complete.

In the level start mode, the start signal is a “level” rather than a pulse. The leading edge of the start signal initiates message playback that continues until either the trailing edge of the start signal occurs or the end of the message is reached. A message that is terminated by the trailing edge of a level start signal is immediately reset and ready for playback again.

**Call routing to RAN trunks**

Software programs in the Meridian 1 control recorded announcement machines. These programs detect the calls to be intercepted, determine the type of intercept treatment required (overflow, attendant, announcement, etc.), queue the intercept, and provide ringback tone to the calling party. At the proper time, an intercepted call is connected to the appropriate RAN trunk.

**Programming RAN trunks**

The type of intercept and the RAN trunk parameters are defined in the Trunk Administration LD 14, Customer Data Block LD 15, and Trunk Route Administration LD 16 programs.

The Trunk Data Block and Route Data Block programs specify the following:

- the RAN trunk
- the type of announcement machine
- the number of repetitions of announcements before a forced disconnect (all calls) or an attendant intercept is initiated (CCSA/DID calls only)
- the point at which the trunk may be connected to the announcement

The Customer Data Block program defines the type of intercept and the trunk route to which the intercept is to be connected.

Refer to the *Software Input/Output Guide Administration* (553-3001-311) for more detailed instructions on service change programs.

## Electrical specifications

Table 4 gives the electrical characteristics of the universal trunk card.

**Table 4**  
**Universal trunk card – trunk interface electrical characteristics**

Characteristic	CO/FX/WATS trunks	DID or TIE trunks	RAN trunks	Paging trunks
Terminal impedance	600 or 900 ohms (Note 1)		600/900 ohms (Note 1)	600 ohms
Balance impedance	600 or 900 ohms (Note 1), 3COM, or 3CM2 (Note 2)		N/A	N/A
Supervision type	Ground or loop start (Note 3)	Loop start (with ans sup) (Note 3)	Continuous, level, or pulse	N/A
DC signaling loop length (max)	1700-ohm loop with near-end battery of -42.75 V	2450-ohm loop with near-end battery of -44 V	600/900-ohm loop	600 ohm loop
Far-end battery	-42 to -52.5 V (Note 4)	-42 to -52.5 V	-42 to -52 V	N/A
Minimum detected loop current	20 mA	10 mA	10 mA	N/A
Ground potential difference	±3 V		±1 V	±1 V
Low DC loop resistance during outpulsing	<300 ohms	N/A	N/A	N/A
High DC loop resistance	Ground start § 30k ohms; loop start § 5M ohms	N/A	N/A	N/A
Ring detection	17 to 33 Hz 40 to 120 V rms	N/A	N/A	N/A
Line leakage	§ 30k ohms, tip-to-ring, tip-to-ground, ring-to-ground		N/A	N/A
AC induction rejection	10 V rms, tip-to-ring, tip-to-ground, ring-to-ground		N/A	N/A
<p><b>Note 1:</b> Selected in software.</p> <p><b>Note 2:</b> Selected by jumper strap settings on card. Refer to Tables 8, 9, and 10 for details.</p> <p><b>Note 3:</b> Loop start answer supervision introduced with vintage BA cards and release 19 software.</p> <p><b>Note 4:</b> For loop extender application, the maximum voltage applied between tip and ring is -105 V ±5%. The minimum dc loop resistance for this type of application is 1800 ohms.</p>				



## Power requirements

Power to the universal trunk card is provided by the module power supply (ac or dc). Table 5 lists the power requirements for the universal trunk card.

**Table 5**  
**Power requirements**

Voltage	Tolerance	Current (max.)
+15.0 V dc	$\pm 5\%$	306 mA
-15.0 V dc	$\pm 5\%$	306 mA
+5.0 V dc	$\pm 5\%$	750 mA
+8.5 V dc	$\pm 2\%$	450 mA
-48.0 V dc	$\pm 5\%$	415 mA

## Foreign and surge voltage protection

The universal trunk card meets UL-1489 and CS03 over-voltage (power cross) specifications and FCC Part 68 requirements.

## Environmental specifications

Table 6 lists the environmental specifications for the universal trunk card.

**Table 6**  
**Environmental specifications**

Parameter	Specifications
Operating temperature	0° to +60° C (+32 to +140° F), ambient
Operating humidity	5 to 95% RH (noncondensing)
Storage temperature	-40° to +70° C (-40° to +158° F)

## Connector pin assignments

The universal trunk card brings the eight analog trunks to the IPE backplane through a 160-pin connector shroud. The backplane is cabled to the input/output (I/O) panel on the rear of the module, which is then connected to the Main Distribution Frame (MDF) by 25-pair cables.

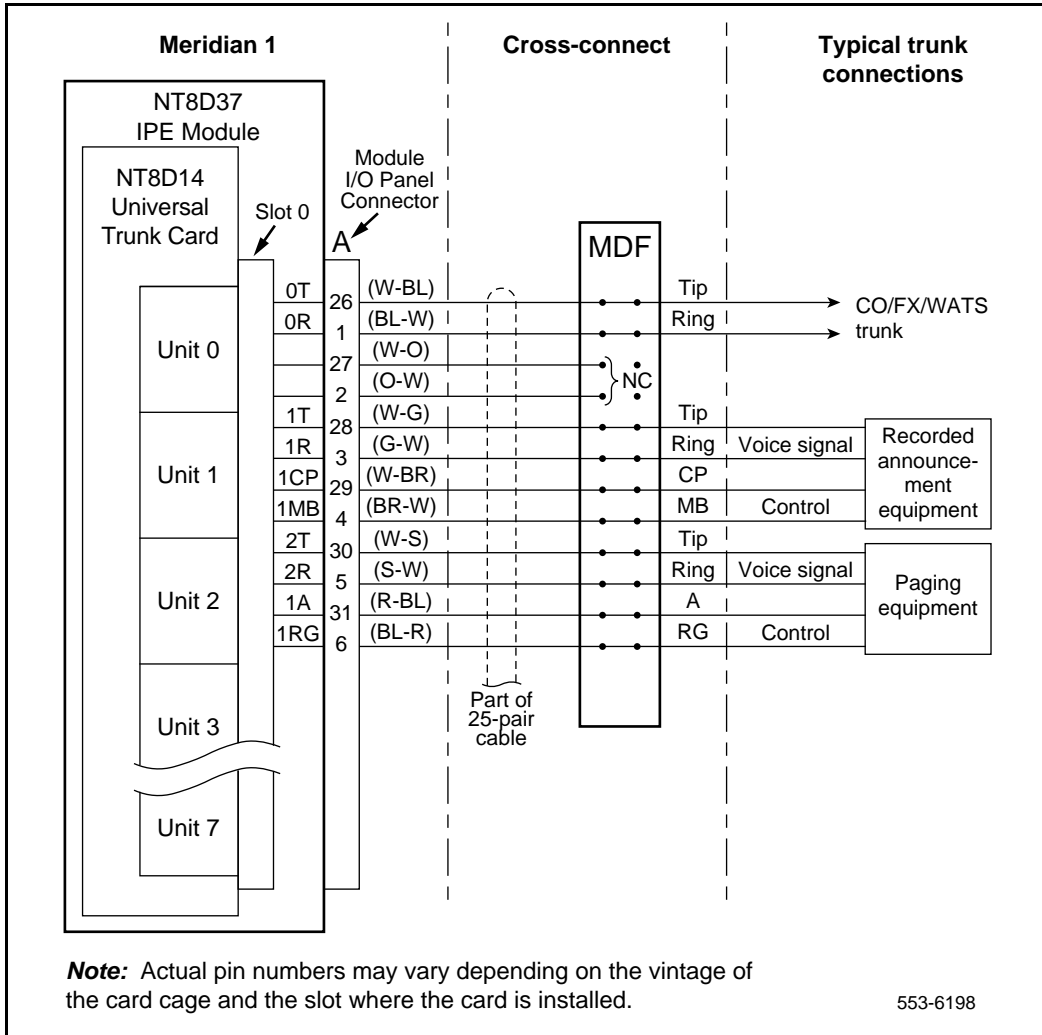
Telephone trunks connect to the universal trunk card at the MDF using a wiring plan similar to that used for line cards. A typical connection example is shown in Figure 30 on page 68, and a list of the connections to the universal trunk card is shown in Table 7 on page 67.

See *System Installation Procedures* (553-3001-210) for more detailed I/O panel connector information and wire assignments for each tip/ring pair.

**Table 7**  
**Universal trunk card – backplane pinouts**

Trunk Number	Back-plane Pin	Signal			Back-plane Pin	RAN mode	Signal		
		RAN mode	Paging mode	Other modes			Paging mode	Other modes	
0	12A	Tip	Tip	Tip	12B	Ring	Ring	Ring	
	13A	CP	A	N/A	13B	MB	RG	N/A	
1	14A	Tip	Tip	Tip	14B	Ring	Ring	Ring	
	15A	CP	A	N/A	15B	MB	RG	N/A	
2	16A	Tip	Tip	Tip	16B	Ring	Ring	Ring	
	17A	CP	A	N/A	17B	MB	RG	N/A	
3	18A	Tip	Tip	Tip	18B	Ring	Ring	Ring	
	19A	CP	A	N/A	19B	MB	RG	N/A	
4	62A	Tip	Tip	Tip	62B	Ring	Ring	Ring	
	63A	CP	A	N/A	63B	MB	RG	N/A	
5	64A	Tip	Tip	Tip	64B	Ring	Ring	Ring	
	65A	CP	A	N/A	65B	MB	RG	N/A	
6	66A	Tip	Tip	Tip	66B	Ring	Ring	Ring	
	67A	CP	A	N/A	67B	MB	RG	N/A	
7	68A	Tip	Tip	Tip	68B	Ring	Ring	Ring	
	69A	CP	A	N/A	69B	MB	RG	N/A	

**Figure 30**  
**Universal trunk card – typical cross connect example**



## Configuration

The trunk type for each unit on the card as well as its terminating impedance and balance network configuration is selected by software service change entries at the system terminal and by jumper strap settings on the card.

NT8D14BB (Release 10 and higher) has a reduced jumper strap setting on the card. There are only three jumpers, J1.X, J2.X, and J3.X per channel. Tables 8, 9, and 10 show the functionality of these 3 jumpers.

### Jumper strap settings

For most applications, the jumper strap settings remain set to the standard configuration as shipped from the factory. See Table 8 on page 70.

The jumper strap settings must be changed, as shown in Table 9 on page 71, for the following:

- For CO/FX/WATS or TIE trunk loops exceeding 1524 meters (5000 ft.)
- DID trunks exceeding a loop resistance of 600 ohms
- RAN trunks operating in pulse start or level start modes

Figure 32 on page 73 shows jumper locations on the universal trunk card (vintage BA).

**Note:** Refer to *Circuit Card: Installation and Testing* (553-3001-211) for vintage AA jumper strap settings.

### Service change entries

The trunk type, terminating impedance, and balance network are selected by making service change entries in the Trunk Administration program LD 14.

Refer to Table 10 on page 74 to select the proper values for the trunk type and loop length being employed.

Refer to *Meridian 1 Software Input/Output Guide Administration* (553-3001-311) for LD 14 service change instructions.

Before the appropriate balance network can be selected, the loop length between the near-end (Meridian 1) and the far-end (a Central Office, for example) must be known. To assist in determining loop length, some

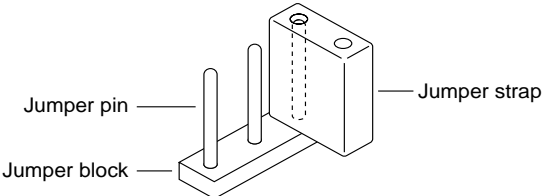
typical resistance and loss values for the most common cable lengths are given in Table 11 on page 74, for comparison with values obtained from actual measurements.

**Table 8**  
**Jumper strap settings – factory standard (NT8D14BA, NT8D14BB)**

Trunk types	Loop length	Jumper strap settings (Note 1)			
		J1.X	J2.X	J3.X	J4.X (Note 2)
CO/FX/WATS	0–1524 m (5000 ft.)	Off	Off	1–2	1–2
2-way TIE (LDR)					
2-way TIE (OAID)					
DID	0–600 ohms	Off	Off	1–2	1–2
RAN: continuous operation mode	Not applicable: RAN and paging trunks should not leave the building.	Off	Off	1–2	1–2
Paging					

**Note 1:** Jumper strap settings J1.X, J2.X, J3.X, and J4.X apply to all eight units; “X” indicates the unit number, 0–7. “Off” indicates that no jumper strap is installed on a jumper block. Store unused straps on the universal trunk card by installing them on a single jumper pin as shown below.

**Note 2:** For the NT8D14BB (Release 10 and higher) card, J4.X is not provided on the card. The J4.X jumper setting specified in Table 8 does not apply.



553-6317

**Table 9**  
**Jumper strap settings – extended range (NT8D14BA, NT8D14BB,**  
**NT8D14BB Release 10 and up)**

Trunk types	Loop length	Jumper strap settings (Note 1)			
		J1.X	J2.X	J3.X	J4.X (Note 2)
CO/FX/WATS	> 1524 m (5000 ft)	Off	Off	1–2	2–3
2-way TIE (LDR)					
2-way TIE (OAID)					
DID	> 600 ohms	On	On	1–2	2–3
RAN: pulse start or level start modes	Not applicable: RAN trunks should not leave the building.	Off	Off	2–3	1–2
<p><b>Note 1:</b> Jumper strap settings J1.X, J2.X, J3.X, and J4.X apply to all eight units; “X” indicates the unit number, 0–7. “Off” indicates that no jumper strap is installed on a jumper block.</p> <p><b>Note 2:</b> For the NT8D14BB Release 10 or later card, J4.X is not provided on the board. The J4.X jumper setting specified in Table 9 does not apply.</p>					

**Figure 31**  
**Universal trunk card – jumper locations (for NT8D14BB Release 10 and higher)**

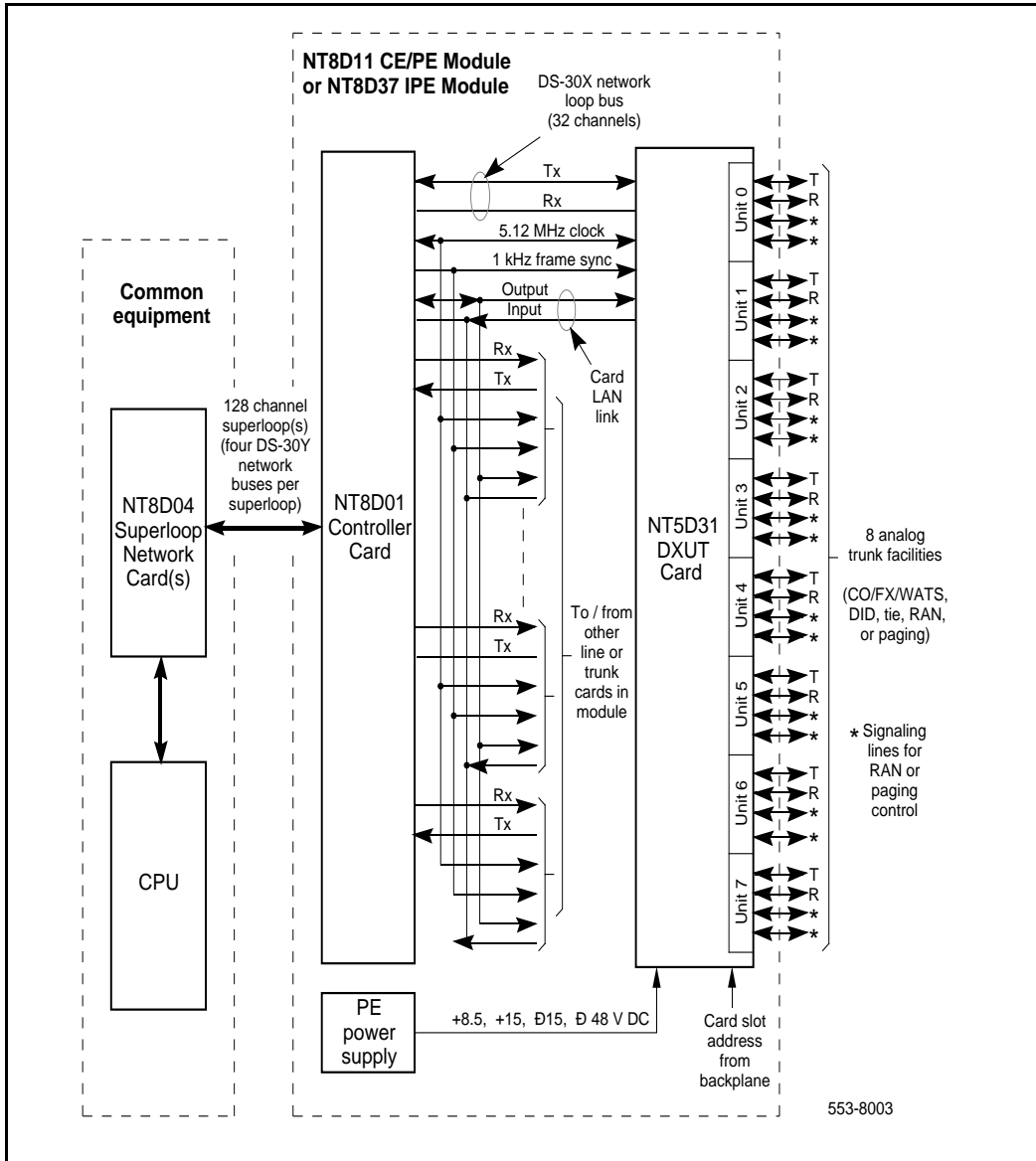
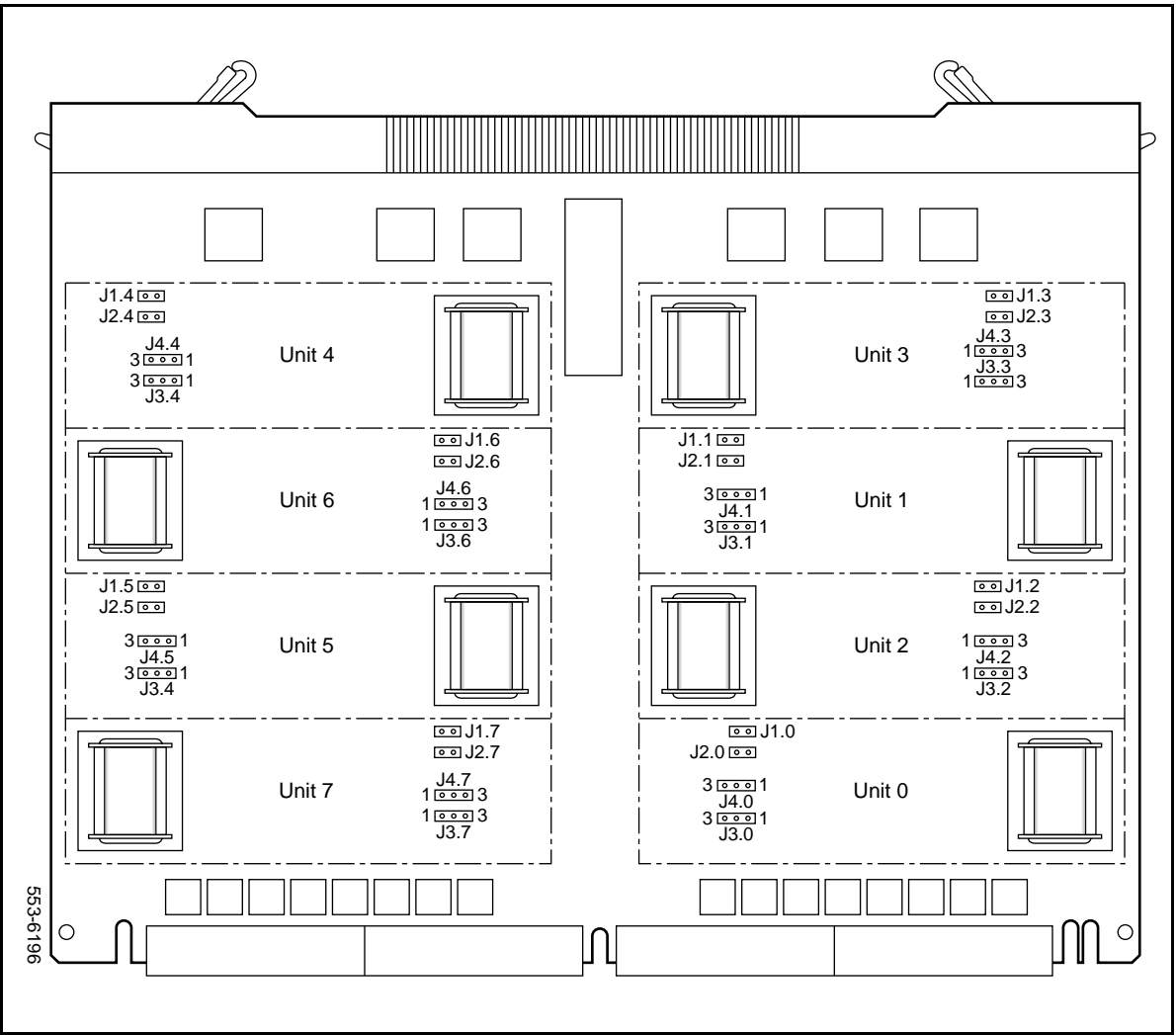




Figure 32  
 Universal trunk card – jumper locations (for NT8D14BA, NT8D14BB Release 9 and below)



**Table 10**  
**Trunk types – termination impedance and balance network (NT8D14BA, NT8D14BB)**

Trunk types	Terminating impedance (Note 1)	Balance network for loop lengths (Note 2)		
		0–915 m (0–3000 ft)	915–1524 m (3000–5000 ft)	> 1524 m (> 5000 ft)
CO/FX/WATS	600 or 900 ohms	600 ohms	3COM	3CM2
2-way TIE (LDR)	600 or 900 ohms	600 ohms	3COM	3CM2
2-way TIE (OAID)	600 or 900 ohms	600 ohms	3COM	3CM2
DID (loop length < 600 ohms)	600 or 900 ohms	600 ohms	3COM	3CM2
DID (loop length $\geq$ 600 ohms)	600 or 900 ohms	600 ohms	N/A	3CM2
RAN: continuous operation mode	600 or 900 ohms	600 or 900 ohms	N/A	N/A
Paging	600 ohms	600 ohms	N/A	N/A

**Note 1:** The terminating impedance of each trunk unit is software selectable in LD 14 and should match the nominal impedance of the connecting equipment.

**Note 2:** The balance network of each trunk unit is software selectable between resistive 600 or 900 ohms or 3COM and jumper selectable between 3COM and 3CM2. Jumper selection for 3COM/3CM2 restriction does not apply to NT8D14BB (Release 10 and later).

**Table 11**  
**Cable loop resistance and loss**

Cable length	Cable loop resistance (ohms)			Cable loop loss (dB) (nonloaded at 1kHz)		
	22 AWG	24 AWG	26 AWG	22 AWG	24 AWG	26 AWG
915 m (3000 ft)	97	155	251	0.9	1.2	1.5
1524 m (5000 ft)	162	260	417	1.6	2.0	2.5
2225 m (7300 ft)	236	378	609	2.3	3.0	3.7
3566 m (11700 ft)	379	607	977	3.7	4.8	6.0
5639 m (18500 ft)	600	960	1544	5.9	7.6	9.4

**Port-to-port loss configuration**

Loss parameters are selected on the Universal trunk card by a switchable pad controlled by CODEC emulation software. For convenience, the pads settings are called “in” and “out.” Pad settings are determined by the two factors listed below:

- Class of Service (CLS) is assigned in LD 14 (under direct user control)
- Port-to-port connection loss is automatically set by software on the basis of the port type selected in LD 16; only the port type is set by the user (controlled indirectly)

The transmission properties of each trunk are characterized by the class of service assigned in LD 14. Transmission properties can be Via Net Loss (VNL) or not Via Net Loss (non VNL).

The VNL class of service is assigned at the prompt CLS with the response VNL. The non-VNL class of service is assigned at prompt CLS by selecting either the Transmission Compensated (TRC) or Non-Transmission Compensated (NTC) response.

Non-VNL trunks are assigned a TRC or NTC class of service to ensure stability and minimize echo when connecting to long-haul trunks, such as TIE trunks. The class of service determines the operation of the switchable pads contained in each unit. They are assigned as follows:

- TRC for a 2-wire non-VNL trunk facility with a loss of greater than 2 dB, or for which impedance compensation is provided, or for a 4-wire non-VNL facility
- NTC for a 2-wire, non-VNL trunk facility with a loss of less than 2 dB, or when impedance compensation is not provided

See Table 12 for the pad switching control for the various through connections and the actual port-to-port loss introduced for connections between the Universal trunk card and any other IPE or PE port designated as Port B.

**Table 12**  
**Pad switching algorithm**

Port B	Port B pads		Universal Trunk Pads		Port-to-port loss (dB)	
	Transmit D to A	Receive A to D	Transmit D to A	Receive A to D	Port B to Universal trunk card	Universal trunk card to Port B
IPE line	N/A	N/A	Out	Out	0.5	0.5
Universal trunk (TRC)	In	Out	In	Out	1	1
IPE TIE (VNL)	In	In	Out	Out	0	0
PE line	N/A	N/A	Out	Out	1	1
PE CO/FX/WATS (TRC)	Out	Out	In	In	1	1
PE TIE	Out	Out	In	In	0.5	0.5

**Note 1:** Transmit and receive designations are from and to the Meridian 1. Transmit is from the Meridian 1 to the external facility (digital-to-analog direction in the Universal trunk card). Receive is to the Meridian 1 from the external facility (analog-to-digital direction in the Universal

**Note 2:** When Port B is the call originating port. If the Universal trunk card is the originating port, the UTC pads are out, the Port B (PE CO/FX/WATS) pads are in.

# Applications

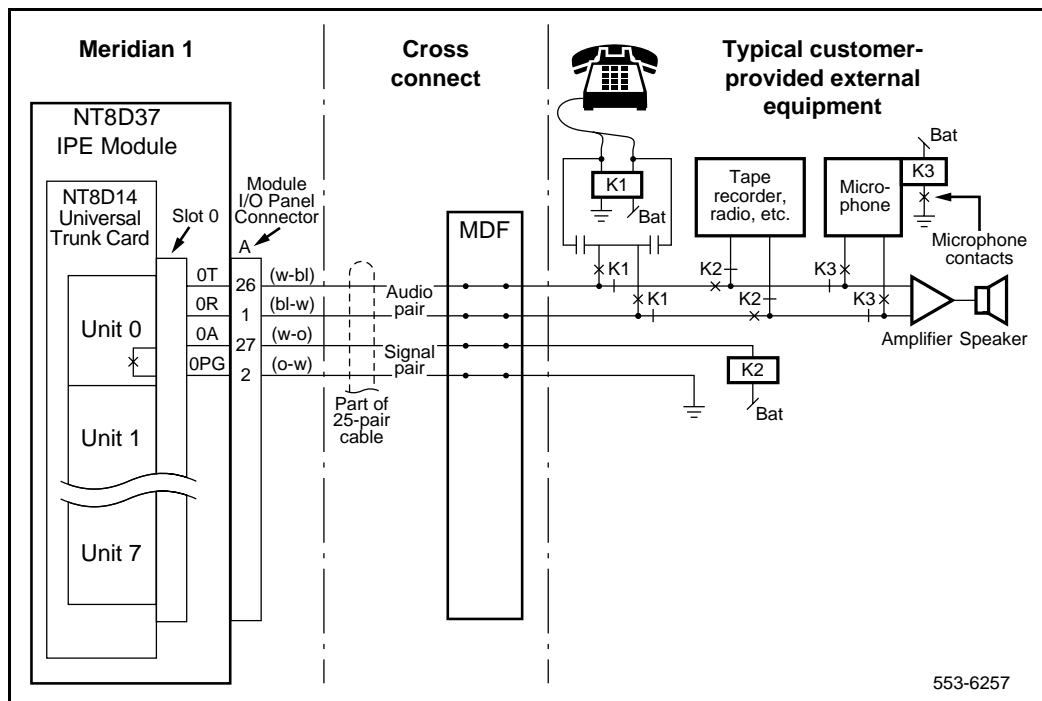
## Paging trunk operation

A universal trunk card unit can be configured as a paging trunk. Configure units as paging trunks in the Trunk Administration program LD 14 and assign routes in the Route Administration program LD 16.

Figure 33 shows a typical connection from customer-provided equipment to unit 0 on a universal trunk card that is installed in slot 0 in an NT8D37 IPE Module.

See *System Installation Procedures* (553-3001-210) for more detailed trunk wiring information.

**Figure 33**  
Connecting paging equipment to the NT8D14 Universal Trunk Card (typical)



## Music operation

A trunk unit can be connected to a music source. The audio source should provide an adjustable power output at 600 ohms.

Configure units for music at the MUS or AWR prompts in the Trunk Administration program LD 14 and assign routes at the MRT prompt in the Trunk Route Administration program LD 16.

Music operation is similar to that of RAN in the continuous operation mode. Connect the unit tip and ring leads to the audio source and ground the CP line at the MDF. See Figure 28 on page 59.

If the music source is equipped with contacts that close when music is online, use these contacts to provide a ground to the MB line; otherwise, ground the MB line at the MDF.

---

# NT8D15 E&M Trunk Card

---

## Contents

This section contains information on the following topics:

Introduction . . . . .	80
Physical description . . . . .	81
Functional description . . . . .	83
Card interfaces . . . . .	84
Card control functions . . . . .	89
Maintenance features . . . . .	91
Operation . . . . .	91
Signaling and call control . . . . .	91
Electrical specifications . . . . .	103
Trunk interface electrical characteristics . . . . .	104
Power requirements . . . . .	105
Environmental specifications . . . . .	105
Foreign and surge voltage protection . . . . .	105
Connector pin assignments . . . . .	105
Configuration . . . . .	109
Jumper settings . . . . .	109
Software service entries . . . . .	109
Applications . . . . .	114
Paging trunk operation . . . . .	114

## Reference list

The following are the references in this section:

- *System Installation Procedures (553-3001-210)*
- *Software Input/Output Guide Administration (553-3001-311)*

## Introduction

The NT8D15 E&M Trunk Card is an Intelligent Peripheral Equipment (IPE) device that can be installed in either the NT8D37 IPE Module or the NT8D11 CE/PE Module. The E&M trunk card interfaces four analog telephone trunks to the Meridian 1 switch. Each trunk interface connects to a trunk facility using tip and ring leads that carry voice, ringing, and tone signaling, and to signaling interfaces by E&M leads. Each unit can be configured independently by software control in the Trunk Administration program LD 14.

The E&M trunk card supports the following types of trunks:

- 2-wire E&M Type I signaling trunks
- 4-wire E&M trunks:
  - Type I or Type II signaling
  - Duplex (DX) signaling
- Paging (PAG) trunks

Type I signaling utilizes two signaling wires plus ground. Type II and DX signaling utilizes two pairs of signaling wires. Most electronic switching systems use Type II signaling.

Table 13 on page 81 lists the signaling and trunk types supported by the E&M trunk card.



**Table 13**  
**Trunk and signaling matrix**

Signaling	Trunk types			
	RLM/RLR	TIE	PAG	CSA/CAA/CAM
2-wire E&M	Yes	Yes	Yes	Yes
4-wire E&M	Yes	Yes	No	Yes

Legend:

- RLM Release Link Main
- RLR Release Link Remote
- CSA Common Control Switching Arrangement
- CAA Common Control Switching Arrangement with Automatic Number Identification (ANI)
- CAM Centralized Automatic Message Accounting (CAMA) trunk

## Physical description

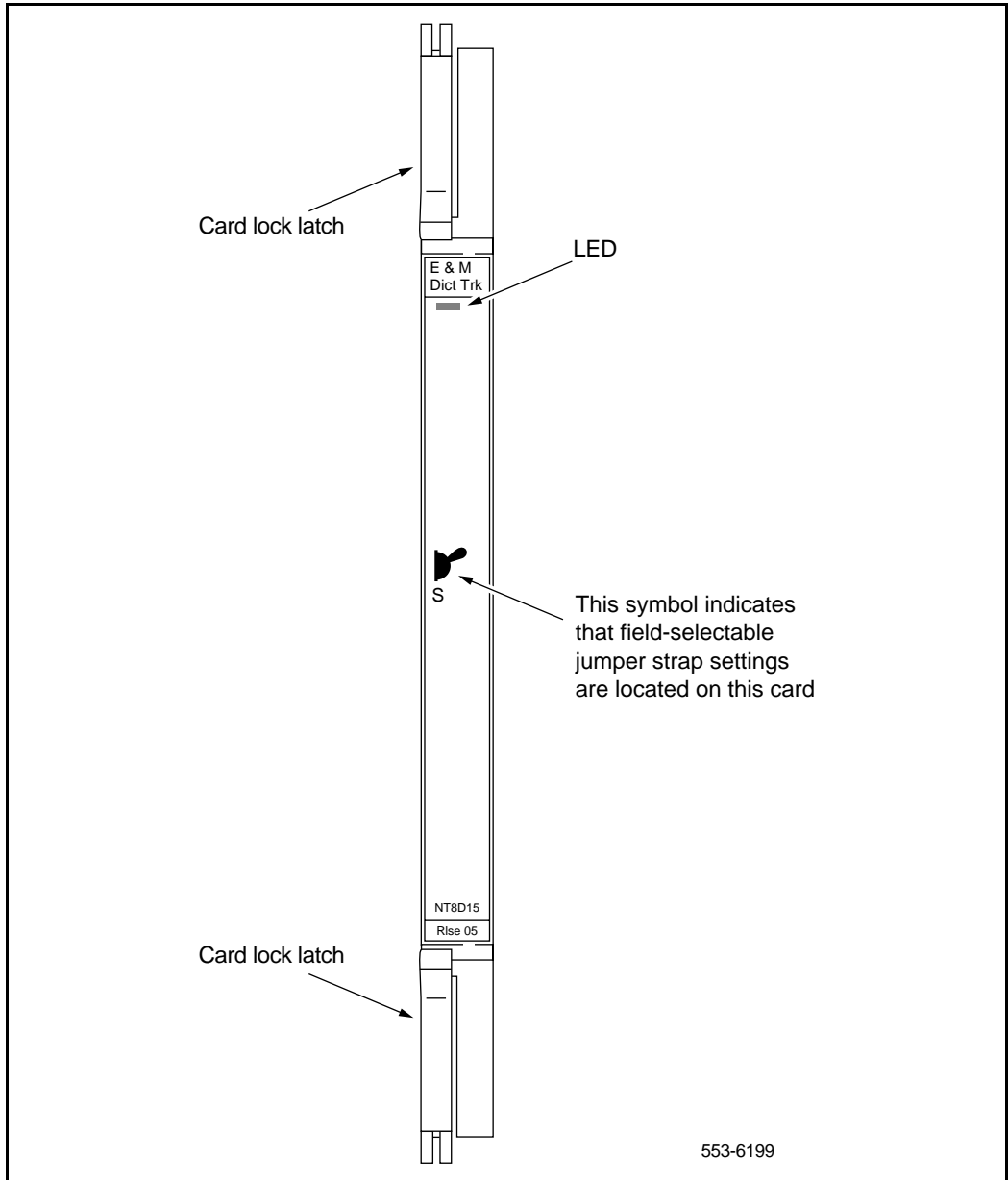
The E&M trunk card mounts in any IPE slot. The line interface and common multiplexing circuitry is mounted on a 31.75 cm by 25.40 cm (12.5 in. by 10 in.) printed circuit board.

The E&M trunk card connects to the IPE backplane through a 160-pin connector shroud. The backplane is cabled to the I/O panel on the rear of the module, which is then connected to the Main Distribution Frame (MDF) by 25-pair cables. Telephone lines from station equipment cross connect to the OPS analog line card at the MDF using a wiring plan similar to that used for line cards. See *System Installation Procedures* (553-3001-210) for termination and cross connect information.

See Figure 34 on page 82 for an illustration of the faceplate on the E&M trunk card. The words “Dict Trk” appear on the faceplate label because earlier versions of this card provided dictation trunk connections for third-party equipment.

The faceplate of the card is equipped with a red LED. When an E&M trunk card is installed, the LED remains lit for 2 to 5 seconds while the self-test runs. If the self-test completes successfully, the LED flashes three times and remains lit. When the card is configured and enabled in software, the LED goes out. If the LED continues to flash or remains weakly lit, replace the card.

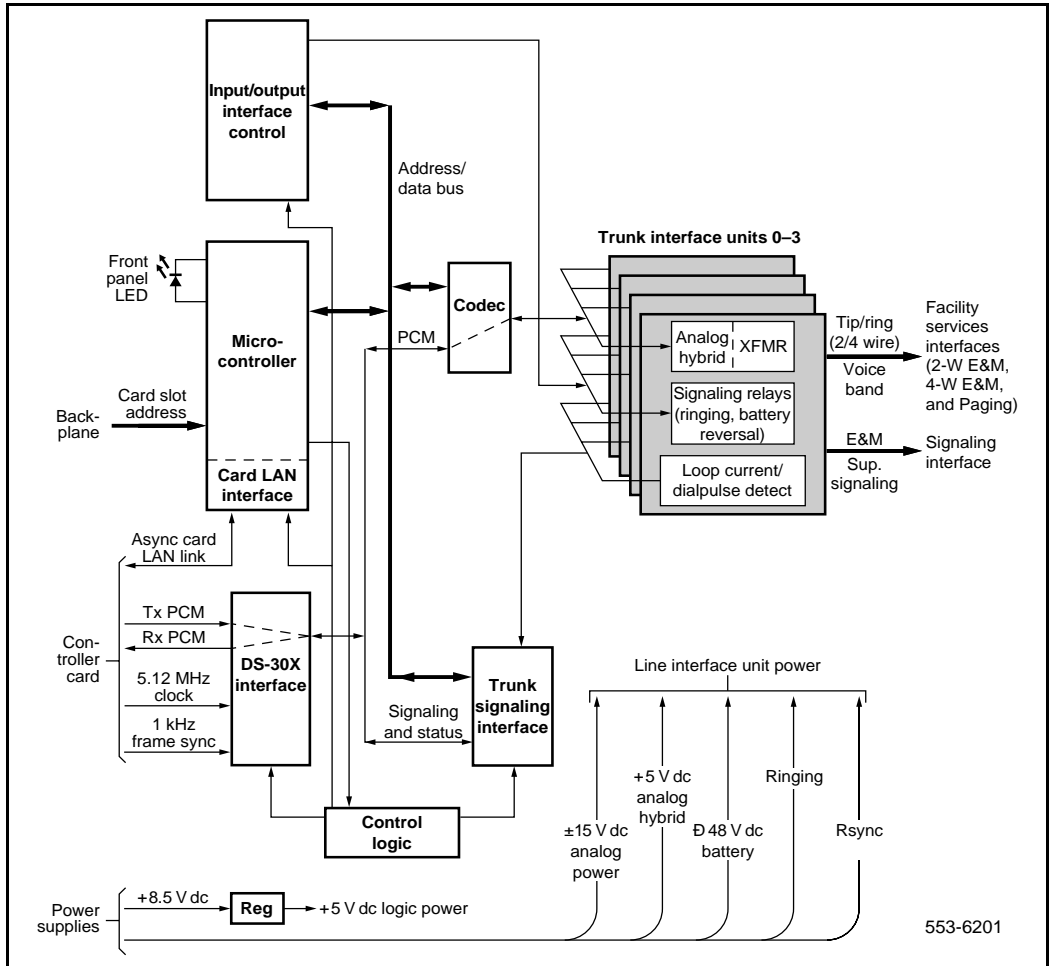
Figure 34  
E&M trunk card – faceplate



## Functional description

Figure 35 shows a block diagram of the major functions contained on the E&M trunk card. Each of these functions is discussed on the following pages.

**Figure 35**  
E&M trunk card – block diagram



## Card interfaces

The E&M trunk card passes voice and signaling data over DS-30X loops, and maintenance data over the card LAN link. See “Intelligent peripheral equipment (IPE) trunk cards” on page 10.

The E&M trunk card contains four identical and independently configurable trunk interface units (also referred to as circuits). Each unit provides impedance matching and a balance network in a signal transformer/analog hybrid circuit. Also provided are relays for placing outgoing call signaling onto the trunk. Signal detection circuits monitor incoming call signaling. A Codec performs A/D and D/A conversion of trunk analog voiceband signals to digital PCM signals.

The four units on the card can operate in the A-Law or the  $\mu$ -Law companding mode. The mode is selected by making service change entries. Each unit can be independently configured for 2-wire E&M, 4-wire E&M, and paging trunk types. The trunk type is selected by service change entries and jumper strap settings. All units on the card can perform the following features:

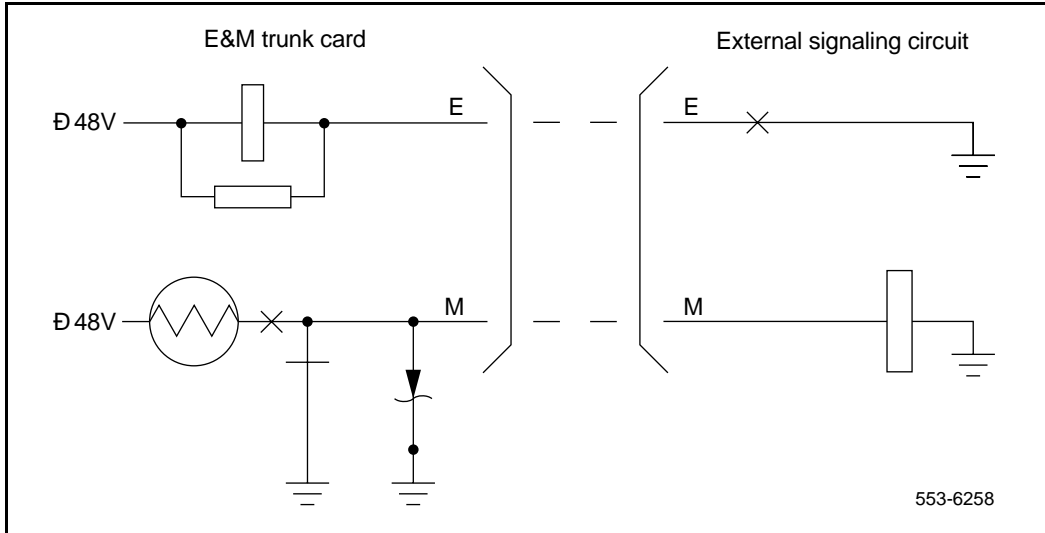
- convert transmission signals from analog-to-digital and digital-to-analog
- provide outpulsing on the card: make/break ratios are defined in software and downloaded at power-up and by software command
- provide 600-ohm balance and termination impedance (2-wire configuration)
- provide 600-ohm termination impedance (4-wire configuration)
- provide pad control for 2-wire and 4-wire facility connections
- allow trunk type and function to be configured on a per port basis in software
- provide isolation of foreign potentials from transmission and signaling circuit
- provide software control of A-Law and  $\mu$ -Law modes
- support loopback of pulse code modulation (PCM) signals to DS-30X for diagnostic purposes

**Trunk unit functions**

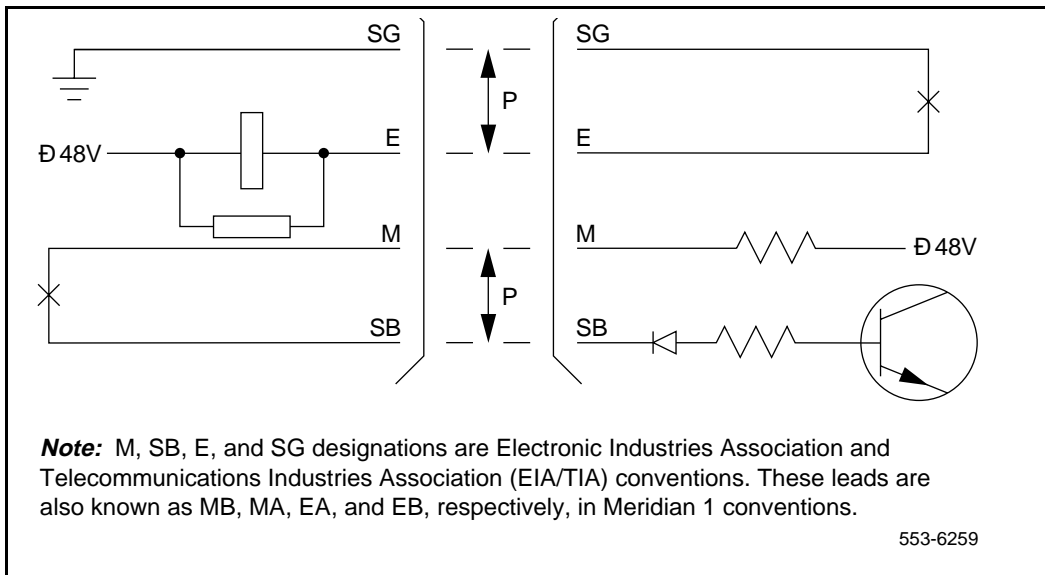
The functions provided by each unit on the E&M trunk card include 2-wire signaling, 4-wire signaling, and paging operation as follows:

- 2-wire, E&M Type I signaling (see Figure 36 on page 86) with:
  - near-end seizure and outpulsing with M lead
  - ground detection with E lead
  - voice transmission through tip and ring for transmit and receive
- 4-wire, E&M Type I and II signaling (see Figure 37 on page 86), 2-way dial repeating with:
  - echo suppression for Type I signaling
  - switchable 7 dB and 16 dB pads for carrier interface
  - voice transmission and reception through two separate paths
  - Type I signaling through E&M leads
  - Type II signaling with near-end seizure by SB/M leads and far-end detection by E/SG leads
- 4-wire, DX signaling (see Figure 38 on page 87)
- paging trunk operation (see Figure 39 on page 88) with:
  - support access by low-resistance path at the PG/A1 leads
  - paging end-to-end signaling not supported

**Figure 36**  
E&M Type I signaling

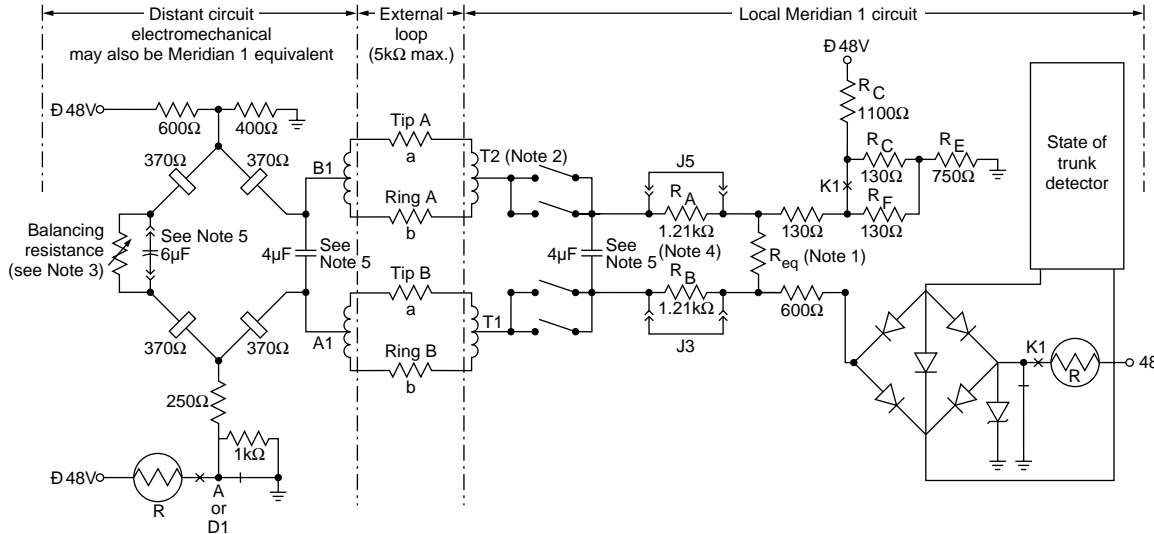


**Figure 37**  
E&M Type II signaling



**Note:** M, SB, E, and SG designations are Electronic Industries Association and Telecommunications Industries Association (EIA/TIA) conventions. These leads are also known as MB, MA, EA, and EB, respectively, in Meridian 1 conventions.

**Figure 38**  
4-wire DX signaling



**Note 1:** The equivalent bridge circuit resistance as seen from distant trunk during the signaling is  $1250 \pm 125$  Ohms.

**Note 2:** T1 and T2 resistance is 47 Ohms for 600 Ohm termination option.

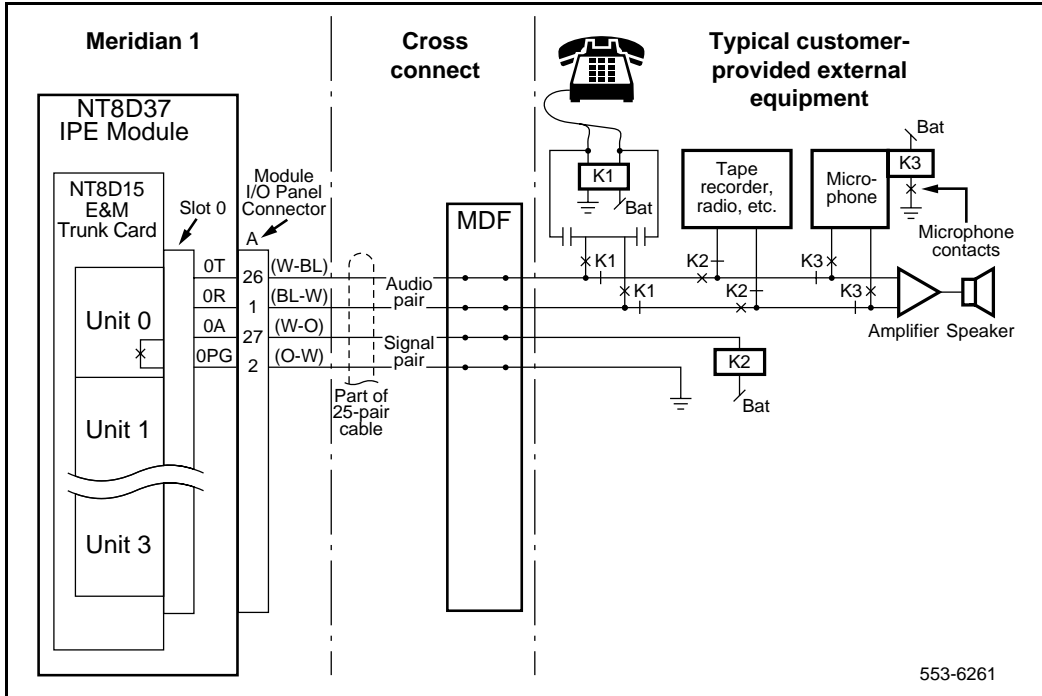
**Note 3:** Compute total balancing resistance as follows (note that in some new DX circuits, a 1260 Ohm resistor is permanently wired in series with the selectable resistance). Total balancing  $R = \text{external loop resistance} + 0.5 \times T1 \text{ resistance} + 0.5 \times T2 \text{ resistance} + [(R_A + R_D) \text{ if not shorted out}] + R_{eq}$ . Resistance of transformers at electromechanical end is low and can be ignored. "External loop resistance" is defined as 1/2 the loop resistance of one cable pair.

**Note 4:** If the external loop is  $>2500$  Ohms, the loop adjustment resistors  $R_A$  and  $R_B$  are in the circuit. When the Meridian 1 is connected to another Meridian 1 or pulse and external loop resistance is  $<2500$  Ohms, the loop adjustment resistors must be shorted in one machine. If the external loop is  $>2500$  Ohms, the loop adjustment resistors must be shorted out in both machines.

**Note 5:** When the Meridian 1 is connected to an electromechanical trunk using 4-wire operation, a 4μF capacitor must be connected from the A1 to B1 lead at each end of the trunk. (These may already be installed.) It is also recommended that a 6μF capacitor be connected in series with the balancing resistance.

553-626C

Figure 39  
Paging trunk operation





## **Card control functions**

Control functions are provided by a microcontroller, a card LAN, and signaling and control circuits on the E&M trunk card.

### **Microcontroller**

The E&M trunk card contains a microcontroller that controls the internal operation of the card and the serial communication link to the NT8D01 Controller Card. The microcontroller provides the following functions:

- card-identification
- self-test
- control of card operation
- status report to the controller
- maintenance diagnostics

### **Card LAN**

The card LAN provides a serial communication link for transferring maintenance data and control signals between the trunk card and the NT8D01 Controller Card. The card LAN controls the microcontroller. The following functions are supported:

- providing card ID/RLS
- reporting self-test status
- polling from the controller card
- enabling/disabling of the DS-30X link

## Signaling and control

The signaling and control portion of the E&M trunk card works with the system CPU to operate the card hardware. The card receives messages from the CPU over a signaling channel in the DS-30X loop and returns status information to the CPU over the same channel. The signaling and control portion of the card provides analog loop terminations that establish, supervise, and take down call connections.

Configuration information for the E&M trunk card is downloaded from the CPU at power-up and by command from maintenance programs. Seven configuration messages are sent. One message is sent to each of the four units to configure trunk and signaling type. The remaining three messages are sent per card to select the make/break ratio and the A-Law and  $\mu$ -Law modes.

The signaling and control circuits on the card perform the following functions:

- provide interface between the card and the system CPU
  - transmit PCM signals from each of the four units to one DS-30X timeslot in A10 format (ready to send/clear to send—flow control, handshake format)
  - transmit and receive signaling messages over a DS-30X signaling channel in A10 format
- decode received messages to set configuration and activate/deactivate interface relays for PCM loopback diagnostic purposes
- decode outpulsing messages (one per digit) from the CPU to drive outpulsing relays at 20 pps, 10 pps1 (primary), or 10 pps2 (secondary)
- monitor signals from the trunk interface and generate a message when required for each state change
- control disabling and enabling of unit or card
- control of A-Law and  $\mu$ -Law operation modes
- control of transmission pad settings

## Maintenance features

The following features are provided for maintenance of the E&M trunk:

- indication of card status from self-test
- software enable and disable capability for individual units or entire card
- loopback of PCM signals to DS-30X for diagnostic purposes
- card ID for autoconfiguration and to determine the serial number and firmware level of the card

## Operation

The optional applications, features, and signaling arrangements for each unit on the E&M trunk card are assigned through the Trunk Administration LD 14 and Trunk Route LD 16 programs.

See the *Software Input/Output Guide Administration* (553-3001-311) for detailed information on assigning features and services to trunks.

## Signaling and call control

The information in this section describes the signaling and call control of E&M Type I and II trunks. The call is terminated and the trunk released by a disconnect message sent to the associated unit.

Figure 40 on page 92 shows the E&M trunk signaling orientation for a tandem connection between E&M and CO trunks.

### E&M Type I signaling

Figure 41 on page 93 shows E&M Type I signaling patterns for incoming and outgoing calls. Figure 42 on page 94 shows Type I signaling patterns on a tandem connection where the originating end is senderized and the route is over a CO/FX/WATS trunk (not applicable to CCSA).

### ***Idle state***

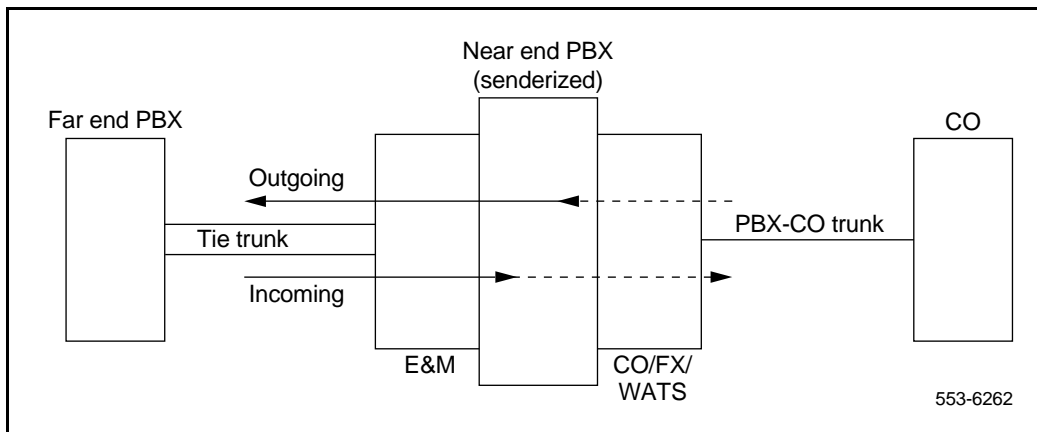
For E&M signaling, in the idle state the M lead is ground and the E lead is an open circuit.

**Outgoing calls**

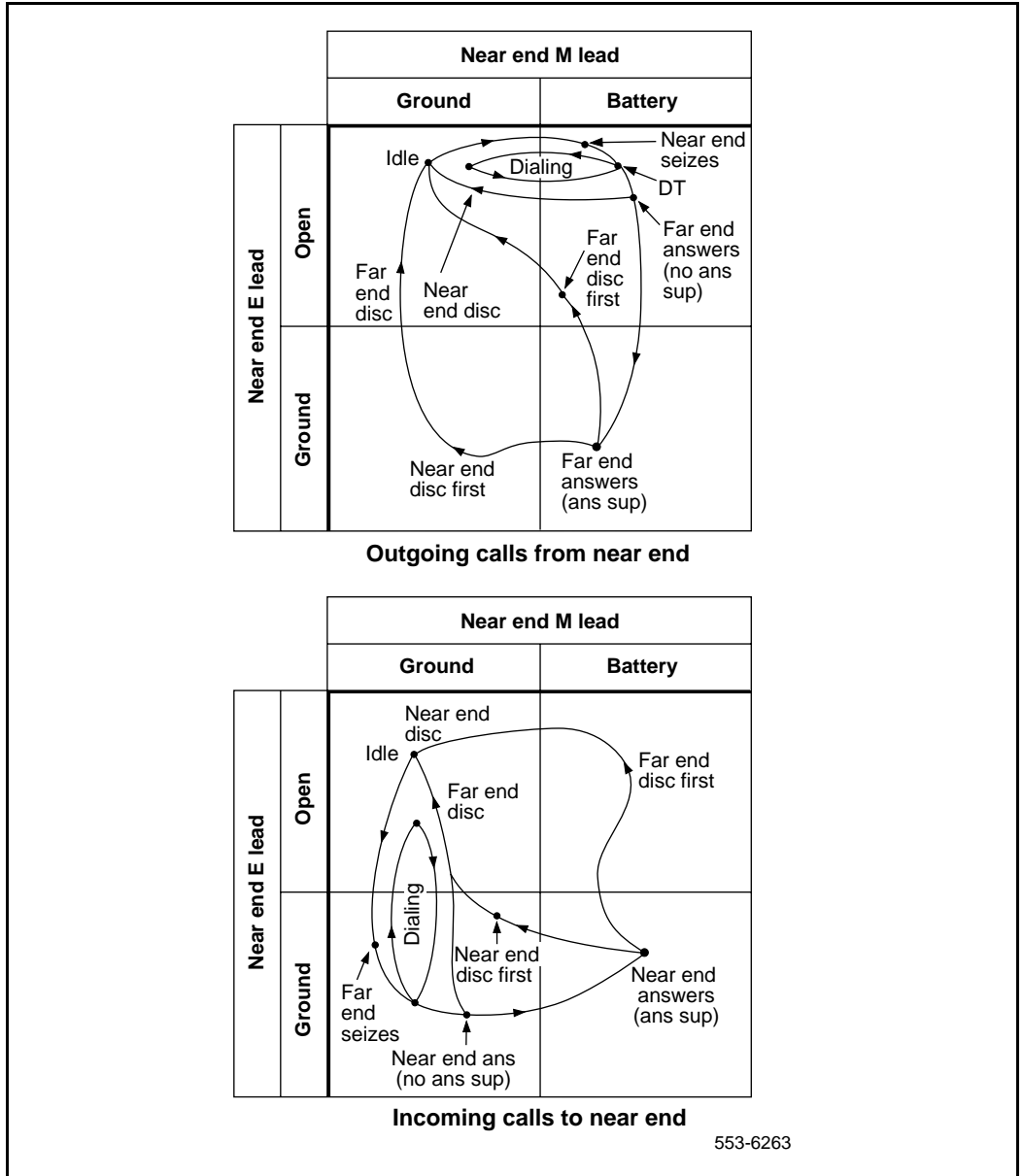
Outgoing calls are processed as follows:

- The M lead changes from ground to battery.
  - If answer supervision is provided by the far-end, there is a change from open to ground on the E lead (ground detection).

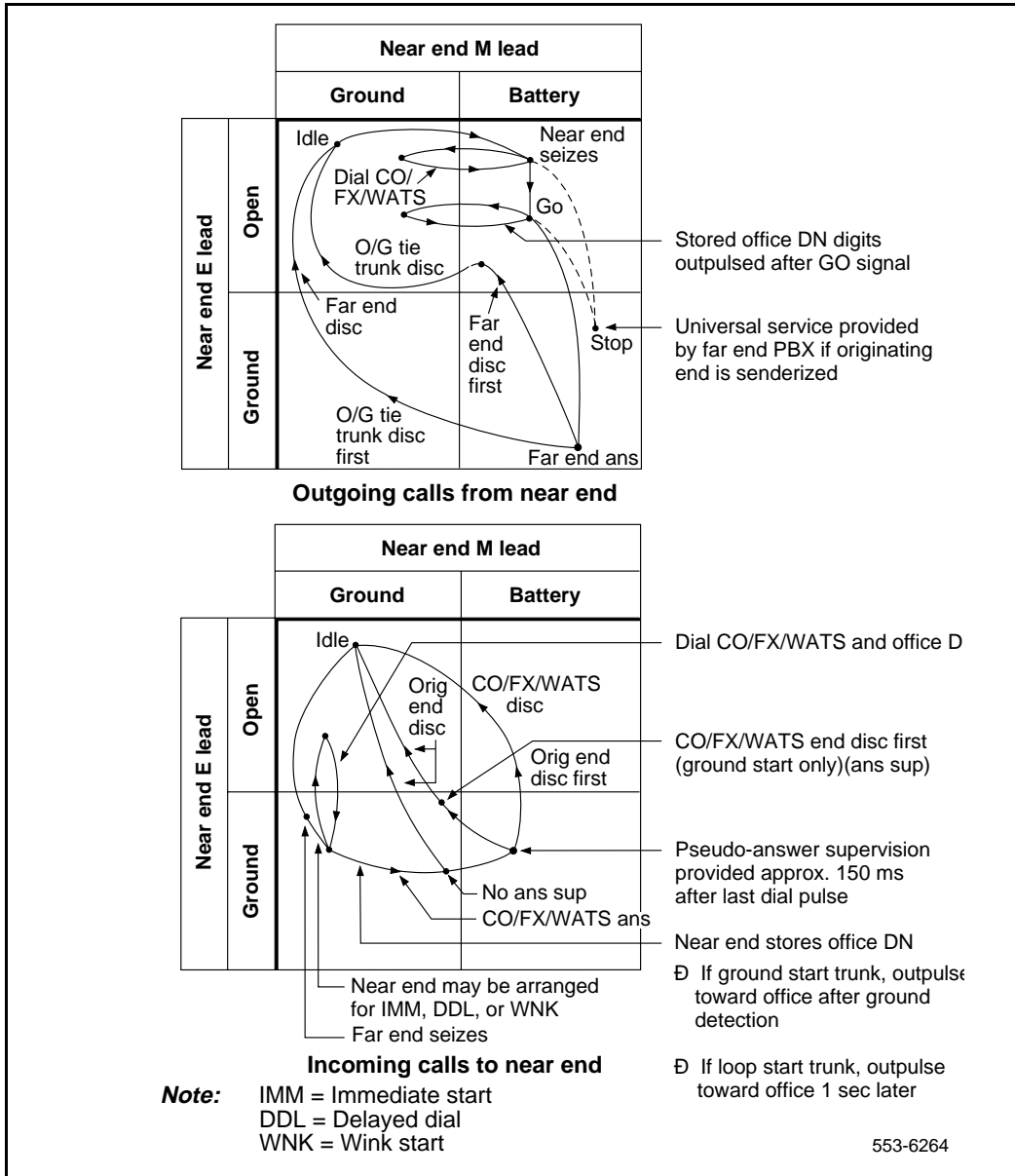
**Figure 40**  
**Signaling orientation for tandem connection between E&M and CO trunks**



**Figure 41**  
**E&M Type I signaling patterns – originating party release**



**Figure 42**  
**E&M Type I signaling patterns – originating party release on a tandem connection**



***Incoming calls***

The far-end initiates calls as follows:

- Ground is placed on the E lead in E&M signaling.
- Dial pulses are subsequently applied from the far-end as ground open on the E lead.
- If the far-end is equipped for sending, the system may be operated in any mode (immediate start, delay dial, or wink start), as assigned on a start arrangement basis. See Table 14 on page 96.
  - In immediate start mode, there is no start signal from the called office. The seizure signal (off hook supervisory state) from the far-end should be at least 150 ms. At the end of the seizure signal, the far-end may start pulsing after the standard delay (normally 70 ms minimum).
  - In delay dial mode, a 256–384 ms off hook/on hook signal is returned to the far-end immediately after receipt of the seizure signal. When the far-end detects the on hook state of the signal (the start signal), the far-end may start pulsing after the standard delay (normally 70 ms minimum).
  - In wink start mode, within a 128–256 ms period after receipt of the seizure signal from the far-end, the called office transmits a 250 ms, wink start, off hook/on hook signal to the calling office.

**Table 14**  
**Operation mode**

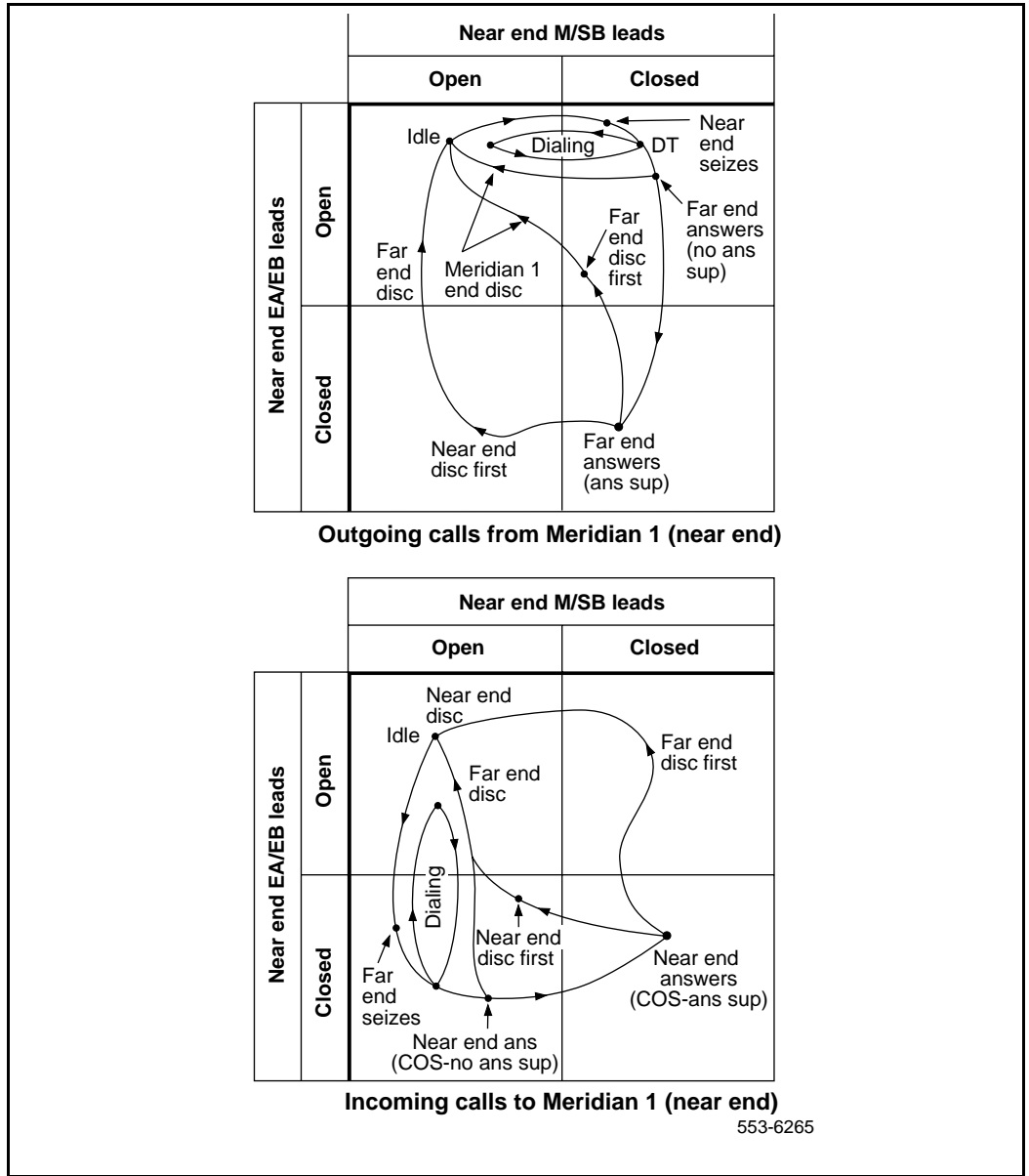
<b>Operation mode</b>	<b>Start arrangement</b>
Immediate start	IMM
Delay dial	DDL
Wink start	WNK

**E&M Type II signaling**

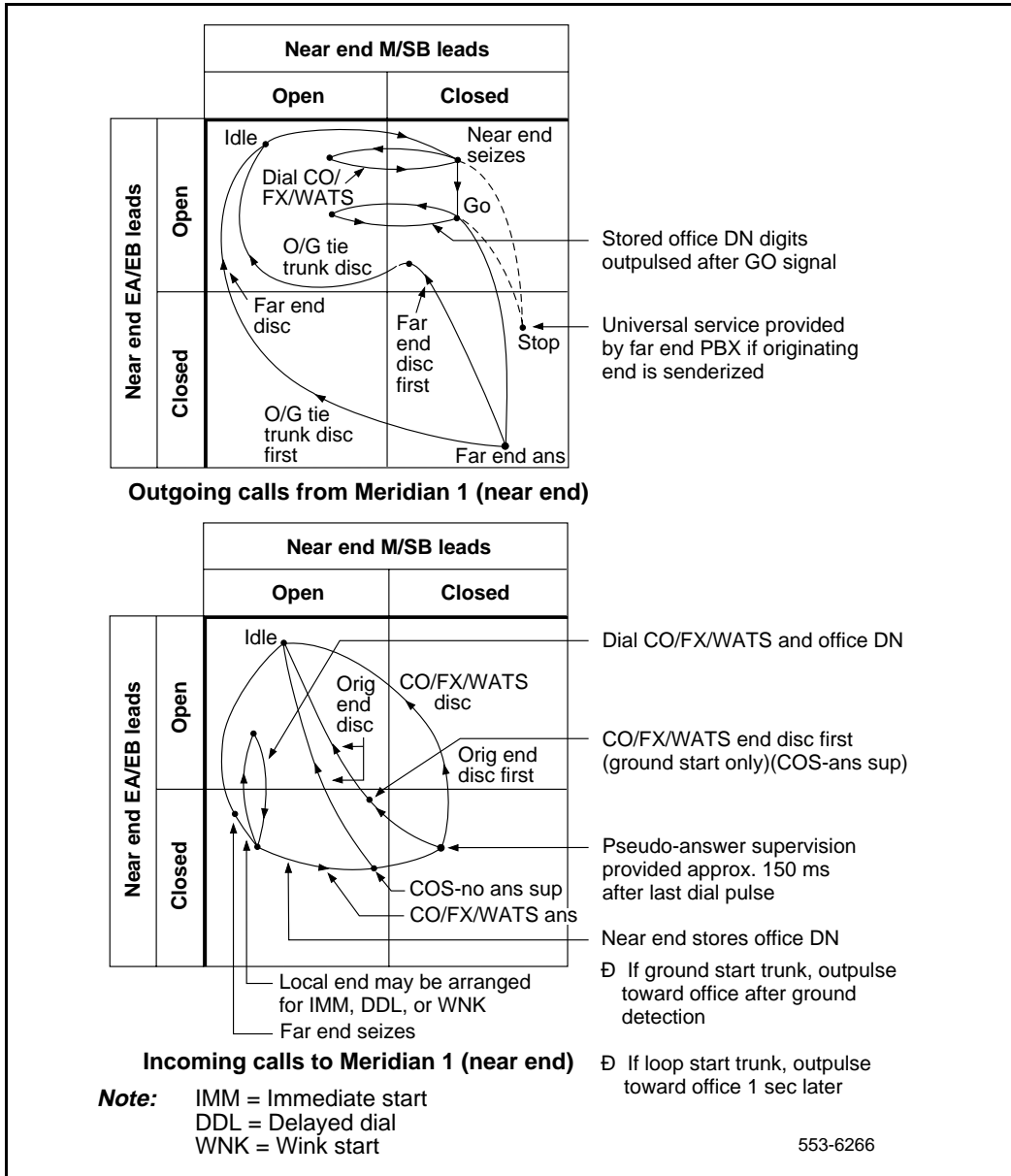
Figure 43 on page 97 shows E&M Type II signaling patterns for incoming and outgoing calls. Figure 44 on page 98 shows Type II signaling patterns for a tandem connection where the originating end is senderized and the route is over a CO/FX/WATS trunk (not applicable to CCSA).



**Figure 43**  
**E&M Type II signaling patterns – originating party release**



**Figure 44**  
**E&M Type II signaling patterns – originating party release on a tandem connection**



Type II signaling uses four leads: M, SB, E, and SG. Instead of changes of state between battery and ground (M signals) or open and ground (E signals), the trunk signals by closing the contacts between the lead pairs M and SB. Signals are received by detecting current flow between lead pairs E and SG.

On incoming calls, the far-end seizes the trunk by shorting the E and SG leads together. This transmits the ground from the SG lead to the E lead (in Type I signaling the ground to the E lead comes from the far-end). Dialing is done by opening and closing the E/SG contacts. Since the SB and M leads are also used as the ESCG and ESC leads, respectively, for echo suppression, echo suppressor control cannot be used with Type II signaling.

*Note:* M, SB, E, and SG designations are Electronic Industries Association and Telecommunications Industries Association (EIA/TIA) conventions. These leads are also known as MB, MA, EA, and EB, respectively, in Meridian 1 conventions.

### **Release control**

Release control of a call made over a trunk is specified in LD 16. Disconnect supervision is specified for each trunk group independently. The two options available are EITHER or ORIGINATING party control. These can be specified for the Meridian 1 end (near-end), or for the CO or other PBX end (far-end). Joint party control can also be specified for the far-end.

### **Duplex signaling**

Duplex (DX) signaling uses the voice transmission leads for signaling as well as for voice transmission. See “Typical IPE trunk card architecture” on page 16.

For descriptive purposes, the lead pair Tip B/Ring B is designated the signaling pair, whereas the other pair Tip A/Ring A conducts current in the opposite direction to balance the overall current flow between the near and far-ends. During signaling, current flows through both Tip B and Ring B leads in the same direction.

Table 15 on page 100 and Table 16 on page 101 show call-connection and take-down sequencing for DX signaling. Table 17 on page 102 and Table 18 on page 103 show sequencing where the E&M trunk card is used in a tandem PBX.

**Table 15**  
**DX signaling – outgoing calls with originating party release**

Condition	Current in signaling lead	State of trunk detector
Idle	No current flow	High
Seizure (dial tone from far-end: far-end ready for digits)	Current flow	High
Digits	Current flow interrupted for each pulse	High
Far-end answers	No current flow	Low
Far-end on hook first	Current flow	High
Network taken down and trunk idled when near-end goes on hook	No current flow	High
Near-end on hook first, network taken down	Current flow	Low
Far-end on hook, trunk idled	No current flow	High

**Table 16**  
**DX signaling – incoming calls with originating party release**

Condition	Current in signaling lead	State of trunk detector
Idle	No current flow	High
Seizure (dial tone to far-end: near-end ready for digits)	Current flow	Low
Digits	Current flow interrupted for each pulse	Low-high-low for each pulse
Near-end answers	No current flow	Low
Far-end on hook first	Current flow	High
Network taken down and trunk idled	No current flow	High
Near-end on hook first, network taken down	Current flow	Low
Far-end on hook, trunk idled	No current flow	High

**Table 17**  
**DX signaling – outgoing calls with originating party release on tandem connections**

Condition	Current in signaling lead	State of trunk detector
Idle	No current flow	High
Seizure (far-end ready for digits)	Current flow	High
Dial CO/FX/WATS	Current flow interrupted for each pulse	High
Stop sender	No current flow	Low
Go sender (universal service provided by far-end PBX if originating end is senderized)	Current flow	High
CO/FX/WATS offices ready for digits		
Stored Office DN digits	Current flow interrupted for each pulse	High
Outpulsed	No current flow	Low
Far end answers	No current flow	Low
Far end on hook first	Current flow	High
Near end on hook, network taken down, trunk idled	No current flow	High
Near end on hook first, network taken down	Current flow	Low
Far end on hook, trunk idled	No current flow	High

**Table 18**  
**DX signaling – incoming calls with originating party release on tandem connections**

Condition	Current in signaling lead	State of trunk detector
Idle	No current flow	High
Seizure (Meridian 1 may be arranged for IS, DD, or WS)  (near-end ready for digits)	Current flow	Low
Dial CO/FX/WATS and office DN  Stored digits outpulsed on CO/FX/WATS trunk after ground detection if a ground start, but after 3 seconds if a loop start	Current flow interrupted for each pulse	Low-high-low for each pulse
If answer supervision: pseudo-answer supervision is sent approximately 13 seconds after last dial pulse received	No current flow	Low
If no answer supervision: CO end disconnects (if a CO ground start – the trunk is idled and network taken down, but the incoming TIE trunk is held under control of the originating end)	Current flow	Low
Originating end disconnects – network taken down and trunk idled	No current flow	High

## Electrical specifications

This section lists the electrical specifications for the E&M trunk card.

## Trunk interface electrical characteristics

Table 19 lists the electrical characteristics of the trunk interface on the E&M trunk card.

**Table 19**  
**Electrical characteristics**

Characteristic	4-wire trunk	2-wire trunk
Signaling range	Type I 150 ohms Type II 300 ohms loop	Type I 150 ohms
Signaling type	Type I, Type II	Type I
Far-end battery	-42 to -52.5 V dc	-42 to -52.5 V dc
Near-end battery	-42.75 to -52.5 V dc	-42.75 to -52.5 V dc
Ground potential difference	$\pm 10$ V dc	$\pm 10$ V dc
Line leakage between E lead and ground	$\leq 20K\frac{3}{4}$	$\leq 20K\frac{3}{4}$
Effective loss	See pad table (Table 25 on page 113)	See pad table (Table 25 on page 113)
Terminating impedance	600 ohms	600 ohms
Balance impedance	N/A	600 ohms



## Power requirements

Table 20 lists the power requirements for the E&M trunk card.

**Table 20**  
**Power requirements**

Voltage	Tolerance	Max current
+15.0 V dc	±5%	200 mA
-15.0 V dc	±5%	200 mA
+8.5 V dc	±2%	200 mA
-48.0 V dc	±5 %	415 mA

## Environmental specifications

Table 21 provides the environmental specifications for the E&M trunk card.

**Table 21**  
**Environmental specifications**

Parameter	Specifications
Operating temperature	0 to +60 degrees C (32 to +140 degrees F), ambient
Operating humidity	5 to 95% RH (noncondensing)
Storage temperature	-40 to +70 degrees C (-40 to +158 degrees F)

## Foreign and surge voltage protection

The E&M trunk card meets CS03 over-voltage (power cross) specifications and FCC Part 68 requirements.

## Connector pin assignments

The E&M trunk card brings the four analog trunks to the IPE backplane through a 160-pin connector shroud. The backplane is cabled to the I/O panel on the rear of the module, which is then connected to the Main Distribution Frame (MDF) by 25-pair cables.

Telephone trunks connect to the E&M trunk card at the MDF using a wiring plan similar to that used for line cards.

A typical connection example is shown in Figure 45 on page 108; a list of the connections to the E&M trunk card in the various 2-wire modes is shown in Table 22 on page 106; and a list of the connections to the E&M trunk card in the various 4-wire modes is shown in Table 23 on page 107.

See *System Installation Procedures* (553-3001-210) for more detailed I/O panel connector information and wire assignments for each tip/ring pair.

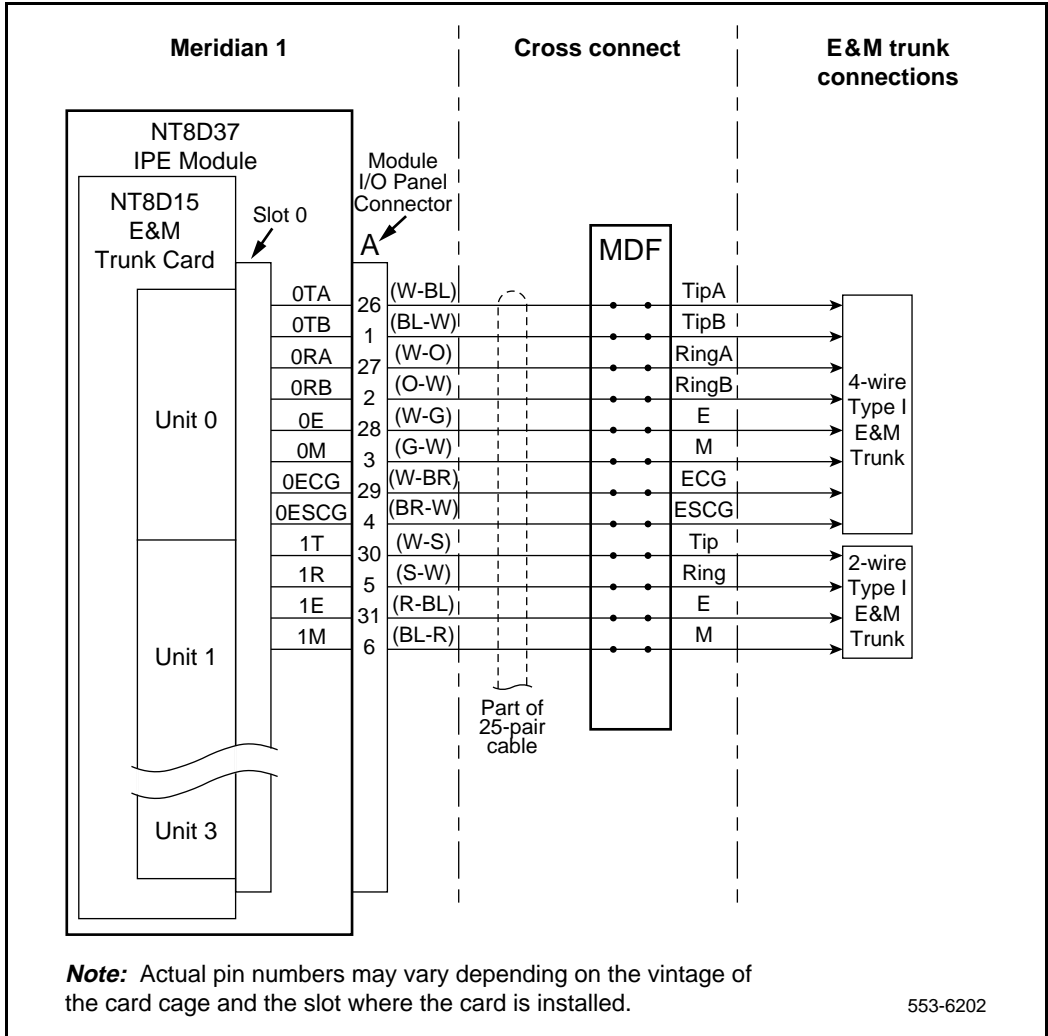
**Table 22**  
**E&M trunk card – backplane pinouts for 2-wire modes**

Trunk Number	2-wire Paging Mode				2-wire Type I Mode			
	Pin	Signal	Pin	Signal	Pin	Signal	Pin	Signal
0	12B	Tip	12A	Ring	12B	Tip	12A	Ring
	15B	A	15A	PG	14B	E	14A	M
1	16B	Tip	16A	Ring	16B	Tip	16A	Ring
	19B	A	19A	PG	18B	E	18A	M
2	62B	Tip	62A	Ring	62B	Tip	62A	Ring
	65B	A	65A	PG	64B	E	64A	M
3	66B	Tip	66A	Ring	66B	Tip	66A	Ring
	69B	A	69A	PG	48B	E	68A	M

**Table 23**  
**E&M trunk card – backplane pinouts for 4-wire modes**

Trunk Number	4-wire Type I Mode				4-wire Type II Mode			
	Pin	Signal	Pin	Signal	Pin	Signal	Pin	Signal
0	12B	TA	12A	TB	12B	TA	12A	TB
	13B	RA	13A	RB	13B	RA	13A	RB
	14B	E	14A	M	14B	EA	14A	EB
	15B	ECG	15A	ESCG	15B	MA	15A	MB
1	16B	TA	16A	TB	16B	TA	16A	TB
	17B	RA	17A	RB	17B	RA	17A	RB
	18B	E	18A	M	18B	EA	18A	EB
	19B	ECG	19A	ESCG	19B	MA	19A	MB
2	62B	TA	62A	TB	62B	TA	62A	TB
	63B	RA	63A	RB	63B	RA	63A	RB
	64B	E	64A	M	64B	EA	64A	EB
	65B	ECG	65A	ESCG	65B	MA	65A	MB
3	66B	TA	66A	TB	66B	TA	66A	TB
	67B	RA	67A	RB	67B	RA	67A	RB
	68B	E	68A	M	68B	EA	68A	EB
	69B	ECG	69A	ESCG	69B	MA	69A	MB

**Figure 45**  
**E&M trunk card – typical cross connection example**



553-6202

## Configuration

Each of the four trunk circuits on the E&M trunk card can be individually configured for trunk type, companding mode, and port-to-port loss compensation. Configuring the card requires both jumper changes and configuration software service entries.

The locations of the jumpers are shown in Figure 46 on page 110.

### Jumper settings

The NT8D15 E&M Trunk Card serves various transmission requirements. The four units on the card can operate in A-Law or  $\mu$ -Law companding modes, which are selected by service change entries. Each unit can be independently configured for 2-wire E&M, 4-wire E&M, and paging trunk types. The trunk type is selected by service change entries and jumper strap settings.

See Table 24 on page 111 and Figure 46 on page 110.

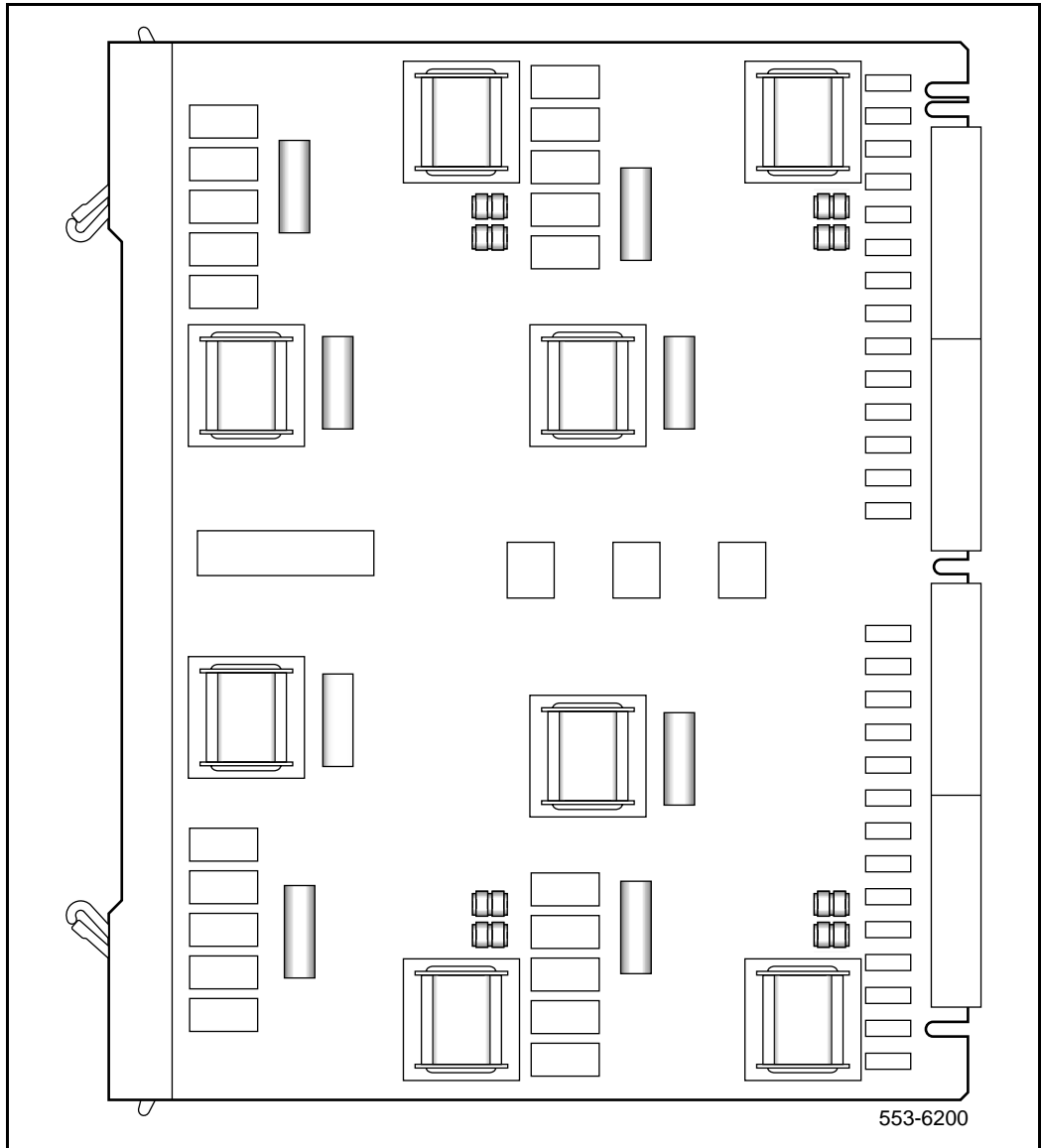
### Software service entries

The trunk type is selected by making service change entries in the Trunk Route Administration Program LD 16. The companding mode is selected by making service change entries in the Trunk Administration Program LD 14.

Refer to Table 24 on page 111 to select the proper values for the trunk type being employed.

Refer to Meridian 1 *Software Input/Output Guide Administration* (553-3001-311) for LD 14 and LD 16 service change instructions.

Figure 46  
E&M trunk card – jumper locations



**Table 24**  
**E&M trunk card – jumper strap settings**

Jumper (Note 1)	Mode of operation (Note 2)					
	2-wire trunk		4-wire trunk			
	Type I	Paging	Type I	Type II	DX tip & ring pair	
					M—rcv E—xmt	E—rcv M—xmt
J1.X	Off	Off	Off	Off	Pins 1–2	Pins 2–3
J2.X	On	On (Note 3)	On	On	Off	Off
J3.X	Off	Off	Off	Off	(Note 4)	(Note 4)
J4.X	Off	Off	Off	Off	Pins 2–3	Pins 1–2
J5.X	Off	Off	Off	Off	(Note 4)	(Note 4)
J6.X	Off	Off	Off	Off	On	On
J7.X	Off	Off	Off	Off	On	On
J8.X	Off	Off	Off	Off	On	On
J9.X	Pins 2–3	Pins 2–3	Pins 2–3	Pins 2–3	Pins 1–2	Pins 1–2

**Note 1:** Jumper strap settings J1.X through J9.X apply to all four units; “X” indicates the unit number, 0–3.  
**Note 2:** “Off” indicates that no jumper strap is installed on a jumper block.  
**Note 3:** Paging trunk mode is not zone selectable.  
**Note 4:** Jumper strap installed in this location only if external loop resistance is greater than 2500 ohms.

### Port-to-port loss configuration

Loss parameters are selected on the E&M trunk card by a switchable pad controlled by Codec emulation software. For convenience in this discussion, the pads settings are called “in” and “out.” Pad settings are determined by the three factors listed below: the first two are under direct user control; the third is controlled indirectly.

- Class of service is assigned in LD 14.
- Facility termination is selected (2-wire or 4-wire) in LD 14 (the 2-wire setting provides 0.5 dB more loss in each direction of transmission for echo control).

*Note:* Facilities associated with the Nortel Networks Electronic Switched Network (ESN) are recommended to be 4-wire for optimum transmission; thus, the 4-wire setting is generally referred to as the ESN setting. However, the 4-wire setting is not restricted to networks using the ESN feature. Conversely, the 2-wire setting, often called non-ESN, can be used on certain trunks in an ESN environment.

- Port-to-port connection loss is automatically set by software on the basis of the port type selected in LD 16; only the port type is set by the user.

The transmission properties of each trunk are characterized by the class of service assigned in LD 14. Transmission properties can be Via Net Loss (VNL) or not Via Net Loss (non-VNL).

The VNL class of service is assigned at the prompt CLS with the response VNL. The non-VNL class of service is assigned at prompt CLS by selecting either the Transmission Compensated (TRC) or Non-Transmission Compensated (NTC) response.

Non-VNL trunks are assigned a TRC or NTC class of service to ensure stability and minimize echo when connecting to long-haul trunks, such as TIE trunks. The class of service determines the operation of the switchable pads contained in each unit. They are assigned as follows:

- TRC for a 2-wire non-VNL trunk facility with a loss of greater than 2 dB, or for which impedance compensation is provided, or for a 4-wire non-VNL facility



- NTC for a 2-wire, non-VNL trunk facility with a loss of less than 2 dB, or when impedance compensation is not provided

See Table 25 for the pad switching control for the various through connections and the actual port-to-port loss introduced for connections between the E&M trunk card and any other IPE or PE port designated as Port B.

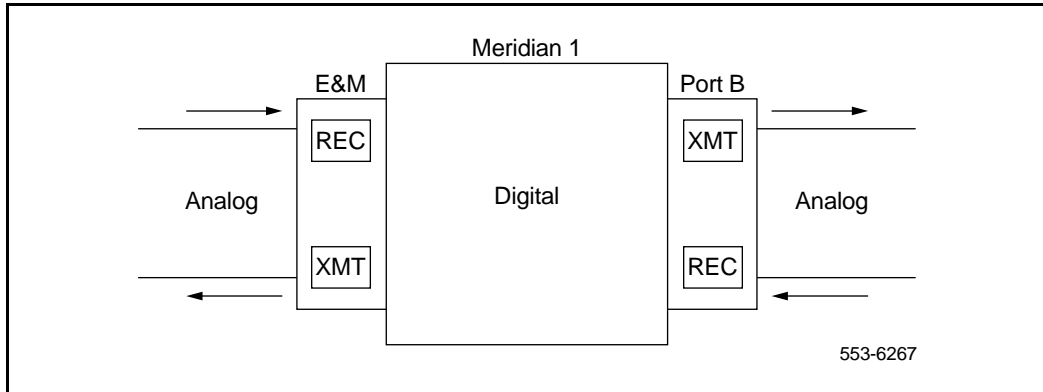
Figure 47 on page 114 shows the pad switching orientation.

**Table 25**  
**Pad switching algorithm**

Port B	Port B pads		E&M Trunk Pads		Port-to-port loss (dB)	
	Transmit D to A	Receive A to D	Transmit D to A	Receive A to D	Port B to E&M	E&M to Port B
IPE line	N/A	N/A	Out	In	2.5	3.5
Universal trunk (TRC)	Out	Out	In	In	0	0
IPE TIE (VNL)	In	Out	In	Out	0	0
PE line	N/A	N/A	Out	In	3.0	4.0
PE CO/FX/WATS (TRC)	Out	Out	In	In	0	0
PE TIE	Out	Out	In	In	0	0

**Note:** Transmit and receive designations are from and to the Meridian 1. Transmit is from the Meridian 1 to the external facility (digital-to-analog direction in the E&M trunk card). Receive is to the Meridian 1 from the external facility (analog-to-digital direction in the E&M trunk card).

**Figure 47**  
**Pad orientation**



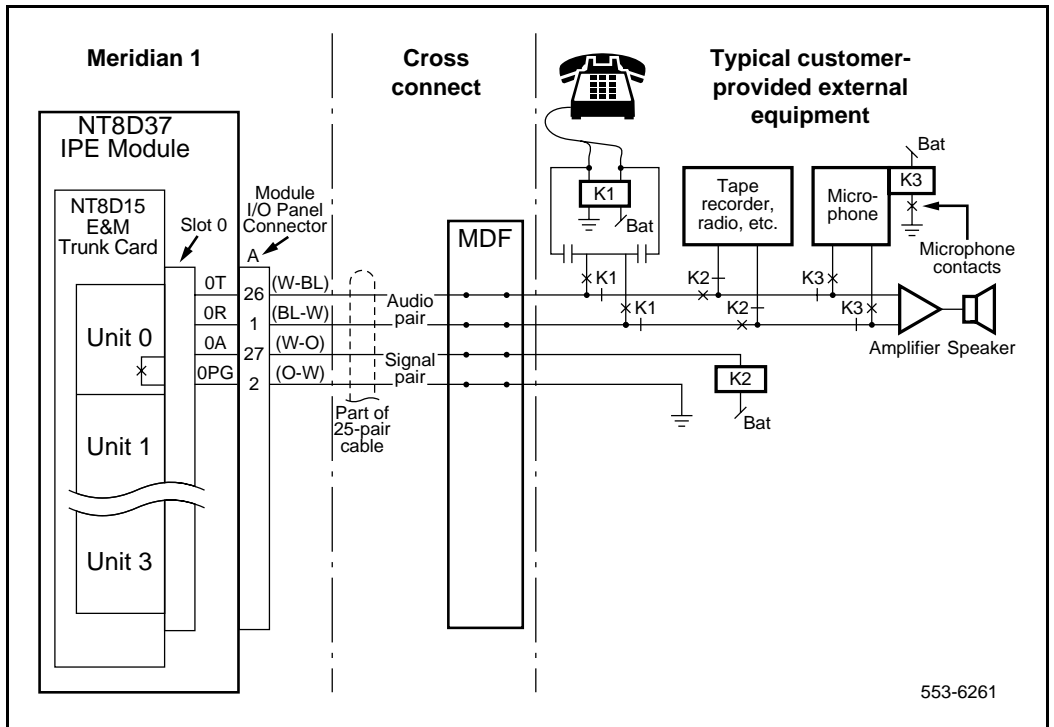
## Applications

### Paging trunk operation

When used in the paging mode, a trunk is connected to a customer-provided paging amplifier system (not zone selectable). When the trunk is accessed by dial-up or attendant-key operation, it provides a loop closure across control leads PG and A1. See Figure 48 on page 115.

In a typical application, this transfers the input of the paging amplifier system to the transmission path of the trunk.

**Figure 48**  
**Paging trunk operation**





---

# NTCK16 Generic Central Office Trunk Cards

---

## Contents

This section contains information on the following topics:

Introduction . . . . .	118
Physical description . . . . .	119
Switch settings . . . . .	119
Self-test . . . . .	119
Functional description . . . . .	119
Common features . . . . .	120
Operation . . . . .	121
Loop start operation . . . . .	121
Electrical specifications . . . . .	122
Power requirements . . . . .	122
Environmental specifications . . . . .	123
Pad switching . . . . .	123
Connector pin assignments . . . . .	123
Cross connections . . . . .	123
Respond to the prompts in LD 16 as shown. . . . .	127
NTCK16AX Central Office trunk card . . . . .	127
NTCK16BX Central office trunk card . . . . .	131
Applications . . . . .	133
Periodic Pulse Metering . . . . .	133

Busy tone detect .....	134
Loss Switching .....	134
Trunk to Trunk connection .....	136
Call Disconnect .....	136

## Introduction

The NTCK16 generic Central Office trunk cards support up to eight analog Central Office trunks. They can be installed in any PE slot that supports Intelligent Peripheral Equipment (IPE). The cards are available with or without the Periodic Pulse Metering (PPM) feature. The cards are also available in numerous countries. Country specific information is provided in this chapter.

The cards are identified by a two-letter suffix to the product code called the vintage. The card vintage is based on whether PPM is equipped or not, and the individual countries where the card is being installed.

The cards listed below are minimum vintage required to support the following countries:

- NTCK16AA generic Central Office trunk card with PPM
  - Ireland
- NTCK16BC generic Central Office trunk card without PPM.
  - Brazil
  - Ireland
  - Mexico
  - Tortolla
  - Singapore

The cards listed below are minimum vintage required to support the following countries:

- NTCK16AD generic Central Office trunk card with PPM
  - Turkey

- NTCK16BD generic Central Office trunk card without PPM.
  - Argentina
  - Turkey
  - Brazil
  - Chile
  - Indonesia
  - Korea
  - Venezuela

Throughout this chapter, cards with PPM will be identified by the vintage AX. Cards without PPM will be referenced by the vintage BX.

## Physical description

The NTCK16AX and NTCK16BX generic Central Office trunk cards have eight units. Each unit connects to the shelf backplane through an 80-pin connector. The backplane is cabled to the I/O panel which is then cabled to the cross-connect terminal.

At the cross-connect terminal, each unit connects to external apparatus by Tip and Ring leads.

## Switch settings

There are no option switches on the NTCK16AX and NTCK16BX generic Central Office trunk cards. All settings are configured in software.

## Self-test

When the NTCK16AX and NTCK16BX trunk cards are installed and power is applied to them, a self-test is performed on each card. The red LED on the faceplate flashes three times, then remains continuously lit until the card is enabled in software. If the self-test fails, the LED remains lit.

## Functional description

The NTCK16AX and NTCK16BX generic Central Office trunk cards support up to eight analog Central Office trunks. They can be installed in any PE slot that supports IPE.

Both cards are exactly the same except for the Periodic Pulse Metering (PPM) feature. The NTCK16AX card supports internal 12/16 kHz PPM but the NTCK16BX card does not.

## Common features

The NTCK16AX and NTCK16BX generic Central Office trunk cards:

- support the North American loss plan
- support loop start signalling
- support busy tone detection and supervision on a per unit basis.
- support battery reversal detection
- provide 4 dB dynamic attenuation pads on a per call basis
- allow individual units or the entire board to be disabled by software
- provide software selectable A-law or  $\mu$ -law companding
- indicate self-test status during an automatic or manual self-test
- provide card-identification for auto configuration, and for determining the serial number and firmware level of the card
- convert transmission signals from analog-to-digital and from digital-to-analog
- provide termination and trans-hybrid balance impedance to match 600  $\Omega$ .



## Operation

Each NTCK16AX and NTCK16BX generic Central Office trunk card supports the following:

- Loop start operation
- Battery reversal detection
- Busy tone detection and supervision
- Loss Switching
- Trunk-to-Trunk connections
- Call Disconnect

In addition, the NTCK16AX circuit card supports internal 12/16 kHz PPM detection.

### Loop start operation

Loop start operation is configured in software and is implemented in the card through software download messages.

#### Idle state

In the idle state, the ringing detector is connected across the tip and ring wires, providing a high impedance loop toward the Central Office.

#### Call placed by Central Office

The Central Office initiates a call by applying ringing between the tip and ring wires. If the call is answered, the ringing detector on the trunk card is switched out and a low resistance dc loop is placed between the tip and ring leads.

On trunks configured for battery supervision, the battery detector records the polarity of the tip and ring wires and sends an answer acknowledge signal to software.

#### Call placed by Meridian 1

To initiate a call, the Meridian 1 switches out the ringing detector and places a low resistance loop across the tip and ring leads. On trunks configured for battery supervision, the trunk card sends a seize acknowledge signal to software.

The Meridian 1 sends digits in the form of Dual Tone Multifrequency (DTMF) tones or pulse digits. When the far-end answers, the Central Office reverses polarity. If the trunk is configured for battery supervision, it sends a polarity reversal message to software.

**Central Office disconnect**

There are two ways the Central Office can disconnect the call:

- by applying busy tone toward the Meridian 1. If the trunk card is configured to detect busy tone, it will send a disconnect message to software.
- by reversing battery. If the trunk card is configured to detect battery reversal, it will send a disconnect message to software. When the unit on the trunk card has been idled, the trunk card sends a release confirm message to software.

**Meridian 1 disconnect**

The Meridian 1 disconnects the call by removing the loop between the tip and ring leads and replacing the ringing detector. Trunks configured for battery supervision send a release confirm message to software.

**Electrical specifications**

**Power requirements**

Table 26 shows the power requirements for the NTCK16AX and NTCK16BX generic Central Office trunk cards.

**Table 26  
NTCK16 circuit card power requirements**

Voltage	Idle Current	Active current
+15.0 V dc (See Note 1)	170 ma	330 ma
-15.0 V dc (See Note 1)	170 ma	249 ma
+8.5 V dc (See Note 2)	101 ma	100 ma
+5.0 V dc	160 ma	322 ma

**Note 1:** Analog circuitry is powered with +/-12 V generated from +/-15 V. The maximum current imbalance between the +/-15 V rails is 100 ma per circuit pack.

**Note 2:** 8.5V is regulated to give 5 V.

## Environmental specifications

Table 27 lists the environmental specifications of the NTCK16AX and NTCK16BX generic Central Office trunk cards.

**Table 27**  
**NTCK16 circuit card environmental specifications**

Parameter	Specifications
Operating temperature	10 to 45 degrees C
Operating humidity	20 to 80% RH (non-condensing)
Storage temperature	-20 to +60 degrees C
Storage humidity	5 to 95% Relative Humidity

## Pad switching

The NTCK16AX and NTCK16BX generic Central Office trunk cards support the North American loss plan. Software configuration allows the selection of 4 dB loss pads on a per unit basis.

**Table 28**  
**NTCK16 pad switching:**

Loss	Analog-to-Digital	Digital-to-Analog
PAD out	0 dB	-3 dB
PAD in	+4 dB	+1 dB

**Note:** The tolerance for the above nominal values is +0.3 dB, -0.7 dB.

## Connector pin assignments

### Cross connections

Figure 49 on page 124, Figure 50 on page 125, and Figure 51 on page 126 provide cross connect information for the NTCK16AX and NTCK16BX generic Central Office trunk cards.

**Figure 49**  
**NTCK16 Central Office trunk connections for NT8D37 I/O panel connectors A, E, K, R**

Lead designations	Pins	Pair Color	I/O Panel Connector				Unit Number
			A	E	K	R	
COT							
T0 R0	26 1	W-BL BL-W					Unit 0
	27 2	W-O O-W					
T1 R1	28 3	W-G G-W					Unit 1
	29 4	W-BR BR-W					
T2 R2	30 5	W-S S-W	S L	S L	S L	S L	Unit 2
	31 6	R-BL BL-R	O T	O T	O T	O T	
T3 R3	32 7	R-O O-R	0	4	8	12	Unit 3
	33 8	R-G G-R					
T4 R4	34 9	R-BR BR-R					Unit 4
	35 10	R-S S-R					
T5 R5	36 11	BK-BL BL-BK					Unit 5
	37 12	BK-O O-BK					
T6 R6	38 13	BK-G G-BK					Unit 6
	39 14	BK-BR BR-BK					
T7 R7	40 15	BK-S S-BK					Unit 7
	41 16	Y-BL BL-Y					

**Figure 50**  
**NTCK16 Central Office trunk connections for NT8D37 I/O panel connectors B, F, L, S**

Lead designations	P i n s	P a i r C o l o r	I / O P a n e l C o n n e c t o r				U n i t N u m b e r
			B	F	L	S	
T0 R0	26 1	W-BL BL-W					Unit 0
	27 2	W-O O-W					
T1 R1	28 3	W-G G-W					Unit 1
	29 4	W-BR BR-W					
T2 R2	30 5	W-S S-W	S L	S L	S L	S L	Unit 2
	31 6	R-BL BL-R	O T	O T	O T	O T	
T3 R3	32 7	R-O O-R	1	5	9	13	Unit 3
	33 8	R-G G-R					
T4 R4	34 9	R-BR BR-R					Unit 4
	35 10	R-S S-R					
T5 R5	36 11	BK-BL BL-BK					Unit 5
	37 12	BK-O O-BK					
T6 R6	38 13	BK-G G-BK					Unit 6
	39 14	BK-BR BR-BK					
T7 R7	40 15	BK-S S-BK					Unit 7
	41 16	Y-BL BL-Y					
T0 R0	42 17	Y-O O-Y					Unit 0
	43 18	Y-G G-Y					
T1 R1	44 19	Y-BR BR-Y	S	S	S	S	Unit 1
	45 20	Y-S S-Y	L O	L O	L O	L O	
T2 R2	46 21	V-BL BL-V	T	T	T	T	Unit 2
	47 22	V-O O-V	2	6	10	14	
T3 R3	48 23	V-G G-V					Unit 3
	49 24	V-BR BR-V					

**Figure 51**  
**NTCK16 Central Office trunk connections for NT8D37 I/O panel connectors C, G, M, T**

Lead designations	P i n s	P a i r C o l o r	I / O P a n e l C o n n e c t o r				U n i t N u m b e r
			C	G	M	T	
COT							
T4 R4	26 1	W-BL BL-W					Unit 4
	27 2	W-O O-W					
T5 R5	28 3	W-G G-W	S	S	S	S	Unit 5
	29 4	W-BR BR-W	L O	L O	L O	L O	
T6 R6	30 5	W-S S-W	T	T	T	T	Unit 6
	31 6	R-BL BL-R	2	6	10	14	
T7 R7	32 7	R-O O-R					Unit 7
	33 8	R-G G-R					
T0 R0	34 9	R-BR BR-R					Unit 0
	35 10	R-S S-R					
T1 R1	36 11	BK-BL BL-BK					Unit 1
	37 12	BK-O O-BK					
T2 R2	38 13	BK-G G-BK					Unit 2
	39 14	BK-BR BR-BK					
T3 R3	40 15	BK-S S-BK	S	S	S	S	Unit 3
	41 16	Y-BL BL-Y	L O	L O	L O	L O	
T4 R4	42 17	Y-O O-Y	T	T	T	T	Unit 4
	43 18	Y-G G-Y	3	7	11	15	
T5 R5	44 19	Y-BR BR-Y					Unit 5
	45 20	Y-S S-Y					
T6 R6	46 21	V-BL BL-V					Unit 6
	47 22	V-O O-V					
T7 R7	48 23	V-G G-V					Unit 7
	49 24	V-BR BR-V					

## Configuration

The trunk type for each unit on the card is selected by software service change entries at the system terminal.

### NTCK16AX Central Office trunk card

#### Route Data Block

Respond to the prompts in LD 16 as shown.

**LD 16** – Route Data Block for NTCK16AX.

Prompt	Response	Description
REQ	NEW	Define a new unit
TYPE	COT	Define a new Route Data Block
CUST	0 – 99	Enter customer number
ROUT	0 – 511	Enter route number
TKTP	COT	Define trunk type as Central Office
ICOG	IAO	Incoming and Outgoing trunk
CNTL	YES	Change a trunk timer
TIMER	RGV 256	Set Ring Validation Timer to 128 ms.
MR	(NO), PPM, XLD	PPM is off, buffered, or unbuffered on this route.

**Trunk Data Block**

Respond to the prompts in LD 14 as shown:



**LD 14** – Trunk Data Block for NTCK16AX.

<b>Prompt</b>	<b>Response</b>	<b>Description</b>
REQ	NEW	Define a new trunk unit
TYPE	COT	Central Office Trunk
TN	LL SS CC UU	Terminal number of the unit: Loop, Shelf, Card, Unit
XTRK (See Note 1 on page 130.)	XCOT	Type is IPE COT
CDEN	(8D)	Card density is 8D (default)
SIGL	LOP	Loop start signaling
PPID (See Note 2 on page 130.)	Xx	04 Ireland/Turkey 12KHz 03 Turkey 16KHz
BTID (See Note 3 on page 130.)	Xx	Enter the country busy tone ID:  Tortola, Brazil = 10 Mexico = 10 or 08 (depending on CO) Singapore = 11 Ireland = 3 or 9 (depending on CO) Chile, Venezuela, Thailand, Korea = 06. Argentina = 12 or 07, Turkey = 14
SUPN	YES, (NO)	Supervision yes (no)
STYP	BTS	Busy tone supervision enabled
	BAT	Loop break supervision enabled
CLS	SHL, (LOL)	Attenuation Pads In, (Out)

Prompt	Response	Description
	DTN, (DIP)  P20, P12, (P10)	Digitone signaling, (digipulse)  Make-break ratio for pulse dialing speed.

**Note 1:** These prompts are required only for the first unit defined on each NTCK16AX card.

**Note 2:** PPIDFreqMin pulse detection

03 16Kz >70ms  
04 12Kz >70ms

**Note 3:** CountryBTIDCadence

Brazil, Tortola 10250 ms +/- 50 ms on/off  
Mexico 10250 ms +/- 50 ms on/off  
Mexico 8375 ms on/off  
Singapore 11750 ms on/off  
Ireland 3500 +/- 50 ms on/off  
Ireland 9375 - 750 ms on/off  
Kuwait, Chile 6500 +/- 50 ms on/off  
Venezuela, Indonesia 12300 ms on, 200 ms off  
Thailand, Korea 12300 ms on, 200 ms off  
Argentina 12300 ms on, 200 ms off  
Argentina 07250 - 500 ms on/off  
Turkey 1410 seconds of Tone 1:  
200 ms off, 200 ms on; 200 ms off,  
200 ms on; 200 ms off, 200 ms on;  
200 ms off, 600 ms on; followed by  
Tone 2: 200 ms off, 200 ms on.

**NTCK16BX Central office trunk card****Route Data Block**

Respond to the prompts in LD 16 as shown:

**LD 16** – Route Data Block for NTCK16BX.

<b>Prompt</b>	<b>Response</b>	<b>Description</b>
REQ	NEW	Define a new unit.
TYPE	COT	Define a new Route Data Block.
CUST	0-99	Enter customer number.
ROUT	0-511	Enter route number.
TKTP	COT	Define trunk type as Central Office.
ICOG	IAO	Incoming and Outgoing trunk
CNTL	YES	Change a trunk timer.
TIMER	RGV 256	Set Ring Validation Timer to 128 ms.
MR	(NO)	PPM is off on this route.

**Trunk Data Block**

Respond to the prompts in LD 14 as shown:

**LD 14 – Trunk Data Block for NTCK16BX.**

Prompt	Response	Description
REQ	NEW	Define a new trunk unit.
TYPE	COT	Central Office Trunk
TN	LL SS CC UU	Terminal number of the unit: Loop, Shelf, Card, Unit
XTRK (See Note 4 on page 133.)	XCOT	Type is IPE COT
CDEN	(8D)	Card density is 8D (default).
SIGL	LOP	Loop start signaling
BTID (See Note 5 on page 133.)	Xx	Enter the country busy tone ID:  Tortola, Brazil = 10 Mexico = 10 or 08 (depending on CO) Singapore = 11 Ireland = 3 or 9 (depending on CO) Kuwait, Chile, Venezuela, Indonesia, Thailand, Korea = 06. Argentina = 12 or 07, Turkey = 14
SUPN	YES, (NO)	Supervision yes (no)
STYP	BTS	Busy tone supervision enabled
	BAT	Loop break supervision enabled
CLS	SHL, (LOL)	Attenuation Pads In, (Out)

Prompt	Response	Description
	DTN, (DIP)  P20, P12, (P10)	Digitone signaling, (digipulse)  Make-break ratio for pulse dialing speed.

**Note 4:** These prompts are required only for the first unit defined on each NTCK16BX card.

**Note 5:** CountryBTIDCadence

Brazil Tortola 10250 ms +/- 50 ms on/off

Mexico 10250 ms +/- 50 ms on/off

Mexico 8375 ms on/off

Singapore 11750 ms on/off

Ireland 3500 +/- 50 ms on/off

Ireland 9375 - 750 ms on/off

Kuwait, Chile 6500 +/- 50 ms on/off

Venezuela, Indonesia 12300 ms on, 200 ms off

Thailand, Korea 12300 ms on, 200 ms off

Argentina 12300 ms on, 200 ms off

Argentina 07250 - 500 ms on/off

Turkey 1410 seconds of Tone 1:

200 ms off, 200 ms on; 200 ms off,

200 ms on; 200 ms off, 200 ms on;

200 ms off, 600 ms on; followed by

Tone 2: 200 ms off, 200 ms on.

## Applications

### Periodic Pulse Metering

All trunk units on the NTCK16AX trunk card can be individually configured to support the Periodic Pulse Metering (PPM) feature.

**Note:** PPM is available on the NTCK16AX trunk card. It is not supported on the NTCK16BX trunk card.

PPM allows the user of a telephone on a Meridian 1 to keep an accurate record of Central Office calls for billing or administration purposes.

**Detection limits**

Pulses detected by the NTCK16AX circuit card must be within the following limits:

Frequency	11 880 to 12 120 Hz
Level	105 to 1100 mVrms <i>Note:</i> The pack should not be used to detect levels of 1100 mVrms or greater a Tip and Ring, as this may result in noise.
Pulse length	Dependent on PPID – see LD 14

**Busy tone detect**

Busy tone is sent by the Central Office to indicate the release of an established call.

**Detection limits**

The NTCK16AX and NTCK16BX generic Central Office trunk cards can detect busy tone within the following limits:

<b>Frequency</b>	<b>400 to 620 Hz</b>
Level	–30 to 0 dBm
Cadence	See Note 3 on page 130.

**Loss Switching**

The Generic XFCOT is based on the XFCOT design, which is using a static pad download algorithm by default for its loss plan.

The generic XFCOT has to be set explicitly to a Dynamic Pad Switching mode to make it compliant with the standard North American Dynamic Pad Switching mode.

Therefore the following steps must be followed when the Generic XFCOT is installed:

- 1 Define Loss Switching mode.  
Respond to the prompts in LD 97 as shown:

**LD 97** – Defining Loss Switching mode.

Prompt	Response	Description
REQ	CHG	
TYPE	SYSP	IPE system parameters configuration
•		
•		
•		
NATP	YES	select North American transmission plan (See Note)

**Note:** The default to the NATP prompt is NO, and therefore this prompt must always be checked during installation.

**2** Define Loss Switching Class Of Service

Respond to the prompts in LD 14 as shown:

**LD 14** – Defining Loss Switching Class Of Service.

Prompt	Response	Description
REQ	CHG	
TYPE	COT	
XTRK	XCOT	
SIGL	LOP	
•		
CLS	LOL	LOL= Long Line (See Note)

*Note:* The XFCOT uses the CLS Long Line (LOL) and Short Line (SHL) for Loss Switching purposes and that the card and trunk type is different from the XUT.

### **Equivalencies**

The following equivalencies do apply:

- XFCOT COT SHL is equivalent with XUT COT TRC
- XFCOT COT LOL is equivalent with XUT COT NTC.

The entries TRC and NTC will no longer be allowed for the Generic XFCOT.

### **Trunk to Trunk connection**

When any disconnect supervision is configured (CLS = BAT, BTS) the Loop Start Trunk of the Generic XFCOT will be marked as having disconnect supervision and will therefore follow the same rules as a Ground Start Trunk. See feature description “Access Restrictions” in the NTPs

There is no configuration involved for this operation.

### **Call Disconnect**

When any disconnect supervision is configured (CLS = BAT, BTS) the Loop Start Trunk will be released when the disconnect signal is received. This will apply also in call states such as ringing, camp-on, DISA, and Meridian Mail

There is no configuration involved for this operation.



---

# Index

---

## A

AWU (Automatic Wake-Up)  
IPE trunk card support, 11

## B

buses, 13, 18

## C

Card LAN links, 17, 19  
NT8D14 Universal Trunk Card, 30  
NT8D15 E&M Trunk Card, 89  
CO (central office) trunks  
IPE trunk card support, 10, 25  
codecs (coder/decoders), 21  
NT8D14 Universal Trunk Card, 29  
connector pin assignments  
NT8D14 Universal Trunk Card, 66  
NT8D15 E&M Trunk Card, 105  
continuous operation mode for recorded messages,  
62  
control signals, 22

## D

DID (direct inward dial) trunks  
IPE trunk card support, 11  
NT8D14 Universal Trunk Card, 25, 42, 50  
DISA (Direct Inward System Access) trunks  
IPE trunk card support, 11  
DS-30X loops, 17, 18  
DX (Duplex) signaling  
IPE trunk card support, 11  
NT8D15 E&M Trunk Card, 85, 86, 99  
PE card support, 11

## E

E&M signaling support, 11  
electrical specifications  
NT8D14 Universal Trunk Card, 64  
NT8D15 E&M Trunk Card, 103  
environmental specifications  
NT8D14 Universal Trunk Card, 65  
NT8D15 E&M Trunk Card, 105

## F

filters  
variable gain, 22  
FX (Foreign Exchange) trunks  
IPE trunk card support, 10, 25

## G

ground start operation  
NT8D14 Universal Trunk Card, 25, 36

## I

impedance  
matching network, 22  
NT8D14 Universal Trunk Card, 64, 74  
impedance and cable loop resistance/loss  
NT8D14 Universal Trunk Card, 74

incoming calls  
  DID operation, 42  
  DX signaling, 101, 103  
  E&M Type I signaling, 95  
  E&M Type II signaling, 96, 97, 98  
  ground start operation, 36, 37, 38  
  loop start operation, 31, 32, 33  
  OAID operation, 53, 54, 55  
  senderized operation for DID and LDR trunks,  
    50, 51  
  two-way, LDR, TIE trunk operation, 42, 43,  
    44, 45, 46

installation, 11

IPE (intelligent peripheral equipment) trunk cards  
  compared to PE equipment, 15

## J

jumper strap settings  
  NT8D14 Universal Trunk Card, 69, 70, 71, 72,  
    73  
  NT8D15 E&M Trunk Card, 109, 110, 111

## L

LDR (loop dial repeating) trunks  
  IPE trunk card support, 11  
  NT8D14 Universal Trunk Card, 25, 42, 50  
loop start operation  
  NT8D14 Universal Trunk Card, 25, 31, 32, 33,  
    34, 35

## M

maintenance data, 17, 19  
message waiting signaling, 17  
microcontroller  
  NT8D14 Universal Trunk Card, 30  
microcontrollers, 13  
  NT8D15 E&M Trunk Card, 89  
MUS (Music)  
  IPE trunk card support, 11  
  NT8D14 Universal Trunk Card, 78

## N

NRD (no ringing detector), 36

NT8D01 Controller Card, 19  
NT8D13 PE Modules  
  network connections to, 15  
NT8D14 Universal Trunk Card  
  card control functions, 30  
  card interfaces, 29  
  configuration, 69  
  connector pin assignments, 66  
  description, 25, 28  
  DID operation, 42, 50  
  electrical specifications, 64  
  environmental specifications, 65  
  faceplate, 27  
  ground start operation, 36  
  impedance and cable loop resistance/loss, 74  
  jumper strap settings, 69, 70, 71, 72, 73  
  loop start operation, 31  
  music operation, 78  
  paging operation, 77  
  power requirements and protection, 65  
  RAN operation, 58  
  trunk number and types supported, 10, 24, 25  
  two-way, LDR, TIE trunk operation, 42, 50  
  two-way, loop OAID, TIE trunk operation, 53  
NT8D14 Universal Trunk card  
  port-to-port loss configurations, 75

- 
- NT8D15 E&M Trunk Card
    - card control functions, 89
    - connector pin assignments, 105
    - description, 79, 81
    - DX (Duplex) signaling, 85, 86, 99
    - electrical specifications, 103
    - environmental specifications, 105
    - faceplate, 82
    - jumper strap settings, 109, 110, 111
    - maintenance, 91
    - pad switching algorithms and orientation, 76, 113
    - paging trunk operation, 85, 88, 114
    - power requirements and protection, 105
    - software service entries, 109
    - trunk interface units and functions, 85, 86, 87
    - trunk number and types supported, 10, 11, 79, 81
    - Type I signaling and call control, 80, 85, 86, 91
    - Type II signaling and call control, 80, 85, 86, 96
  - NT8D15 E&M Trunk card
    - port-to-port loss configurations, 112
  - NT8D37 IPE Modules
    - network connections to, 15
    - trunk card installation, 12
  - NTCK16 Generic Central Office Trunk Card
    - trunk number and types supported, 10
- O**
- OAID (outgoing automatic incoming dial) trunks
    - IPE trunk card support, 11
    - NT8D14 Universal Trunk Card, 53
  - off hook/on hook signaling, 17
  - outgoing calls
    - DX signaling, 100, 102
    - E&M Type I signaling, 92, 93, 94
    - E&M Type II signaling, 96, 97, 98
    - ground start operation, 39, 40, 41
    - loop start operation, 31, 34, 35
    - OAID operation, 53, 56, 57
    - senderized operation for DID and LDR trunks, 50, 52
    - two-way, LDR, TIE trunk operation, 42, 48, 49
- P**
- pad switching algorithms
    - NT8D15 E&M Trunk Card, 76, 113
  - PAG (Paging) trunks
    - IPE trunk card support, 11
    - NT8D14 Universal Trunk Card, 25, 77
    - NT8D15 E&M Trunk Card, 85, 88, 114
    - PE trunk card support, 11
  - PCM (pulse code modulated) data, 18
  - PE (peripheral equipment) trunk cards
    - compared to IPE equipment, 15
  - polling, 20
    - by Controller Cards, 20
  - port-to-port loss configurations
    - NT8D14 Universal Trunk card, 75
  - port-to-port loss configurations
    - NT8D15 E&M Trunk card, 112
  - power requirements and protection
    - NT8D14 Universal Trunk Card, 65
    - NT8D15 E&M Trunk Card, 105
  - PSP/PIP (polarity-sensitive/-insensitive packs), 31, 39
- R**
- RAN (Recorded Announcement) trunks
    - IPE trunk card support, 11
    - NT8D14 Universal Trunk Card, 25, 58
  - reverse-wiring compensation, 36
  - ringing signaling, 17
- S**
- self-tests, 20
-

- signaling technology
  - circuits, 22
    - DS-30X loops, 18, 21
    - NT8D14 Universal Trunk Card, 30
    - NT8D15 E&M Trunk Card, 90, 91
    - SL-1 network loops, 21
- start mode for recorded messages, 62
- superloops, 19

## **T**

- TCM (time compressed multiplexed) data, 18
- TIE trunks
  - IPE trunk card support, 11
  - NT8D14 Universal Trunk Card, 25, 42, 50, 53
- timeslots, 18
- trunk card, related documents, 7
- trunk cards
  - operation, 13
  - selecting for IPE architecture, 10
  - selecting for PE architecture, 10
  - trunk interface units, 20
- two-way, LDR, TIE trunk operation
  - NT8D14 Universal Trunk Card, 42

## **V**

- variable gain filters, 22

## **W**

- WATS (Wide Area Telephone Service) trunks
  - IPE trunk card support, 10, 25
- words (loop data format), 18, 19

## **X**



Meridian 1  
**Trunk Cards**  
Description

Copyright © 1994 – 2002 Nortel Networks  
All Rights Reserved

Information is subject to change without notice. Nortel Networks reserves the right to make changes in design or components as progress in engineering and manufacturing may warrant. This equipment has been tested and found to comply with the limits for a Class A digital device pursuant to Part 15 of the FCC rules, and the radio interference regulations of Industry Canada. These limits are designed to provide reasonable protection against harmful interference when the equipment is operated in a commercial environment. This equipment generates, uses and can radiate radio frequency energy, and if not installed and used in accordance with the instruction manual, may cause harmful interference to radio communications. Operation of this equipment in a residential area is likely to cause harmful interference in which case the user will be required to correct the interference at their own expense.

SL-1 and Meridian 1 are trademarks of Nortel Networks.

Document number: 553-3001-106

Document release: Standard 7.00

Date: January 2002

Printed in Canada

