Meridian 1

Cabling Guide

Document Number: 553-3001-109

Document Release: Standard 6.00

Date: April 2000

Copyright © 1994– 2000 Nortel Networks
All Rights Reserved

Printed in Canada

Information is subject to change without notice. Nortel Networks reserves the right to make changes in design or components as progress in engineering and manufacturing may warrant. This equipment has been tested and found to comply with the limits for a Class A digital device pursuant to Part 15 of the FCC rules, and the radio interference regulations of Industry Canada. These limits are designed to provide reasonable protection against harmful interference when the equipment is operated in a commercial environment. This equipment generates, uses and can radiate radio frequency energy, and if not installed and used in accordance with the instruction manual, may cause harmful interference to radio communications. Operation of this equipment in a residential area is likely to cause harmful interference in which case the user will be required to correct the interference at their own expense.

SL-1 and Meridian 1 are trademarks of Nortel Networks.

Revision history

April 2000

Standard, release 6.00. This is a global document and is up-issued for X11 Release 25.0x. Document changes include removal of: redundant content; references to equipment types except Options 11C, 51C, 61C, and 81C; and references to previous software releases.

October 1997

Standard, release 5.00.

December 1995

Standard, release 4.00. Reissued to include minor edits.

July 1995

Standard, release 3.00. Reissued to include option 81C information, updated indexing and minor text and graphic edits. Revision bars are used to indicate changes.

April 1995

Standard, release 2.00. Reissued to include editorial changes and indexing. Due to the extent of the changes, revision bars are not used.

December 1994

Standard, release 1.00. Initial release.

Contents

About this document	7
Introduction	9
Module cable routing	11
System configurations	15
Intra-module cabling	21
Inter-module internal cabling	31
System monitor cabling	35
Inter-module external cabling	39
Network to Meridian Mail cabling	45
Module to external equipment cabling	47
System upgrade to Meridian 1	49
Index	129

About this document

This document is a global document. Contact your system supplier or your Nortel Networks representative to verify that the hardware and software described is supported in your area.

This document provides detailed system engineering guidelines, cable routing, and connector assignments for the Meridian 1 system signal cabling, including Meridian Max and Meridian Mail. This document also includes cabling information for upgrade from current SL-1 systems to Meridian 1 Options. Also included are recommended configurations for the Meridian 1 Options 51C, 61C, and 81C systems, as well as migrations from system Options 51C, and 61C to the next system size.

This document does not cover the Meridian 1 system power cabling. It is covered in the NTPs referenced below.

Appendix A lists all cables used in Meridian 1. Appendix B contains all of the cable assignment tables. Appendix C is a cross-reference of the old equipment cable codes to the new Product Engineering Codes.

References

- *System Overview* (553-3001-100)
- *Installation Planning* (553-3001-120)
- *System Engineering* (553-3001-151)
- *System Installation Procedures* (553-3001-210)

Introduction

The Meridian 1 system consists of basic building blocks called universal equipment modules (UEM) or modules. Each module is a self-contained unit with power, a card cage, I/O panels, and cable routing channels. These modules are stacked in one or more columns and are interconnected with cables. These cables connect cards in the same module, between two modules, and between cards and the I/O panel in the same module.

Based on the module application, the following module configurations are available for the Meridian 1 system:

- NT5D21 Core/Network Module, AC or DC
- NT8D35 Network Module, AC or DC
- NT8D36 InterGroup Module
- NT8D37 Intelligent Peripheral Equipment Module, AC or DC
- NT6D44 Meridian Mail Module, AC or DC

Module cable routing

Cables can be routed internally in the module horizontally in front and at the rear of the card cage, vertically on the right side only, and vertically through square holes near the rear of the module (refer to Figures 1 and 2). The gray areas in the figures indicate the areas where cables can be routed.

Cables are routed externally in the back of and on the left and right side of the module between the EMI/RFI I/O panel and the rear cover. The cables may be routed in these channels up to the top of the column or down to the floor through the pedestal. Routing cables on the inside of a module from the front to the back on the left or power supply side is not recommended, due to the limited access in routing the cables and to the effects of EMI/RFI noise generated in this area to signals in the cables.

A typical routing scenario from the faceplate of a printed circuit pack (PCP) to one of the I/O panels is as follows:

- 1 The cable comes off the faceplate of a PCP and drops down into the front horizontal cable trough.
- 2 The cable is routed to the right side of the module in the horizontal cable trough to the vertical cable trough.
- 3 The cable is routed to the back of the module and into the rear horizontal cable trough.
- 4 The cable is routed to the left or right I/O panel at the rear of the module.

When connecting two half-group networks together, the cables are routed vertically through the square holes in the rear horizontal cable trough.

All other internal vertical cable routing from one module to another should be done only in the right vertical cable trough.

Figure 1
Top view of module cabling troughs

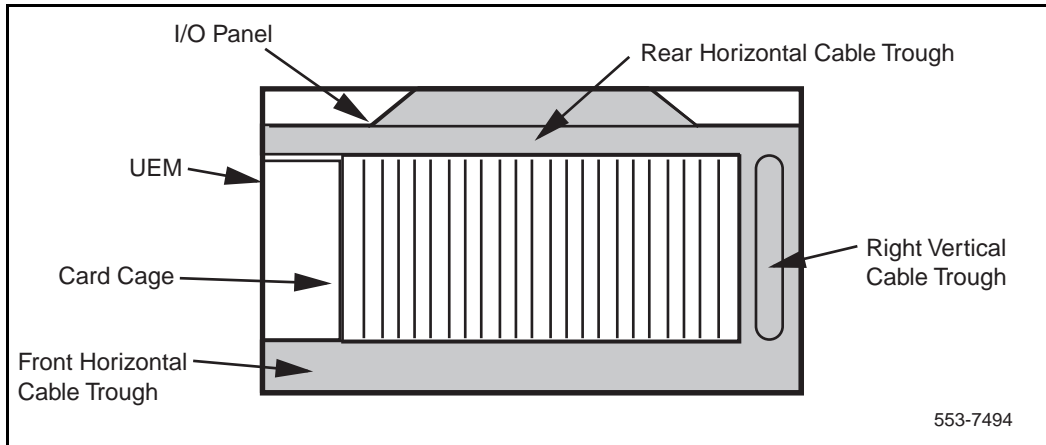
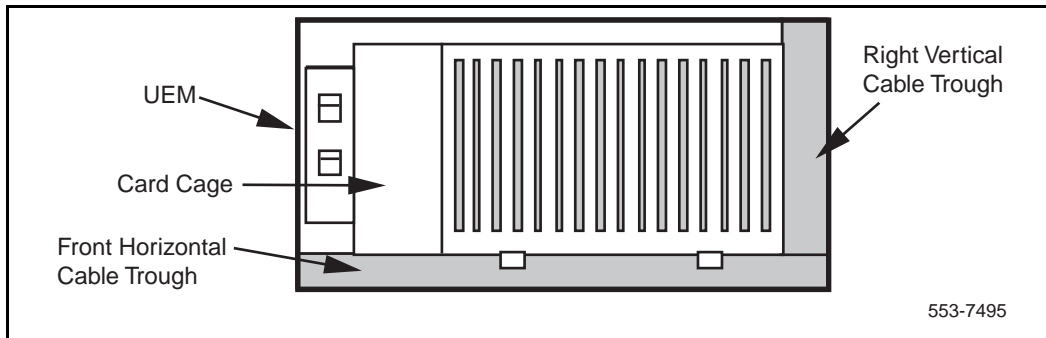
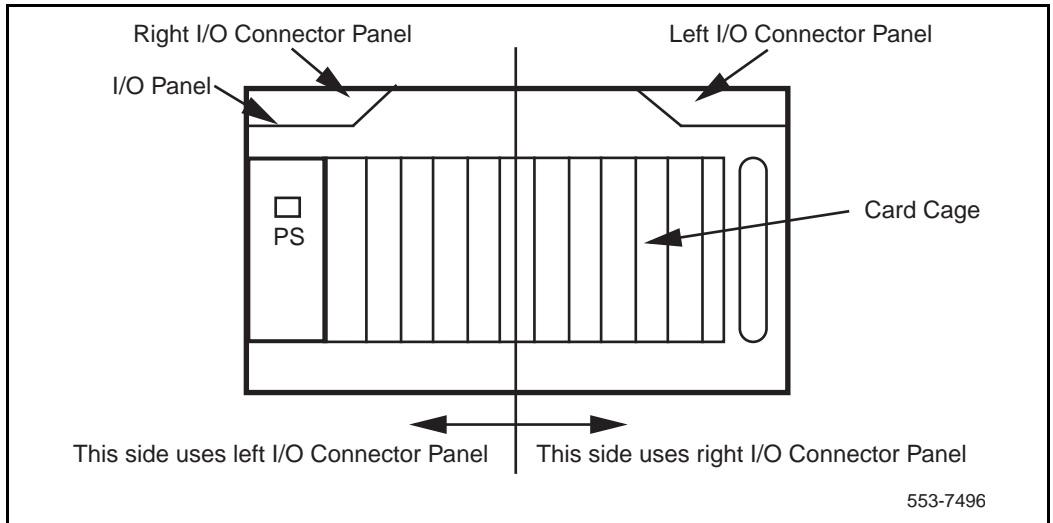

Figure 2
Front view of module cabling troughs



Since all faceplate to I/O panel cables are the same length and the card position in the card cage can vary, a cable may contain excess slack in some of the configurations. It is therefore recommended that cables from cards in the left side of the card cage use the right I/O panel and cables from cards in the right side of the card cage use the left I/O panel whenever possible, as shown in Figure 3.

Figure 3
Top view of front to I/O connector panel routing



553-7496

It is recommended that whenever possible the 90° connector end of the cable be used to route the cable through a module or cabinet instead of the 180° end since some openings are small (see Figures 4 and 5). Cables should also be routed top to bottom as gravity will help ease installation.

Figure 4
90° cable connector

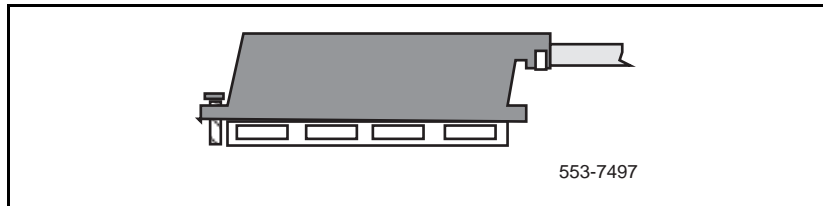
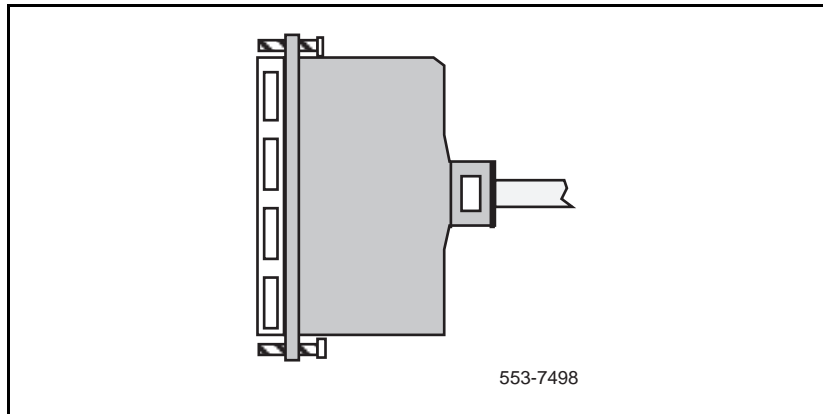

Figure 5
180° cable connector



System configurations

Content list

The following are the topics in this section:

- [Reference list 15](#)
- [System types 15](#)
- [Engineering rules 16](#)
- [Systems 17](#)
- [Options 51C and 61C 17](#)
- [Option 81C 20](#)

Reference list

The following are the references in this section:

- *Hardware Configuration Procedures (553-3001-258)*
- *FNF Reference Guide*

System types

There are two basic systems within the Meridian 1 product line. Their differences are in the architecture of the central processing unit (CPU) or the network and peripherals, with changes made to the system in the Meridian 1 program. These systems are as follows:

- Medium-sized switches are Options 51C, and 61C, which can be configured for up to 1500 lines.
- The largest switch is Option 81C, which provide up to 10,000 ports.

Engineering rules

Each Meridian 1 system is defined using the following assumptions and general engineering rules:

- A system may be upgraded to the next larger system type as defined in *Hardware Configuration Procedures (553-3001-258)*.
- When expanding to the next system type, the changes to the physical configuration must be kept as simple as possible to reduce downtime and installation costs.
- A module column should be built up to the maximum of four modules before moving to the next new column. In installations where the ceiling does not allow four-high columns, the alternate method of three-high tier configurations can be used.
- Vertical routing of the internal signal cables be done only on the right side of a module.
- The CPU modules must be on the bottom of a column or one level up for proper cooling and reliability.
- The network modules cannot be separated. This means that they must be located in one contiguous equipment bay.
- The IPE modules can be located separately from the CPU and network bay, by up to the maximum network cable length of 45 feet.
- A full-group network consists of two half-group network modules stacked one on top of the other.
- Option 81C Core/Network Modules can also be on top of each other in the first and second tier.
- The intergroup module must be at the top of a column and adjacent to the network modules.
- The Meridian Mail module can only be located in the bottom or the next tier higher because of thermal restrictions.

Systems

In the figures that follow, each of the boxes represents a module, as viewed from the front of the system. Boxes with dashed lines indicate where additional modules can be placed for expansion. The pedestals and top caps are not shown as they are always required.

All of the figures show the system with contiguous modules. The system can be split because of floor space limitations, system size, and so on.

Options 51C and 61C

Options 51C, and 61C have Core and network modules located in the same column with the IPE modules, as shown in Figure 6. Options 51C and 61C contain core/network modules. Option 51C is a single-CPU and half-group network configuration. Option 61C has two redundant CPUs and a full group network in two modules.

Installations with low ceilings can use the three-high tiered configuration, as shown in Figure 7. This configuration also applies to the Option 51C if you place the core/network module at the bottom of the column in place of the CPU/network module.

Options 51C, and 61C can be expanded by placing IPE modules on top of or adjacent to the original module column, as shown in Figures 6 and 7.

A full-group Option 61C consists of 32 loops, which is the maximum number of loops supported by this Option. This also applies to the Option 61C when you replace the CPU/network module with a core/network module

Figure 8 shows an upgrade from the single-group Option 61C to the Option 81C. The upgrade consists of installing two Network modules and one intergroup module or Fiber Network. In installations where the ceiling height is too low for the four-tier column, a three-tier column can be used, as shown in Figure 9.

Figure 6
Option 51C with expanded IPE

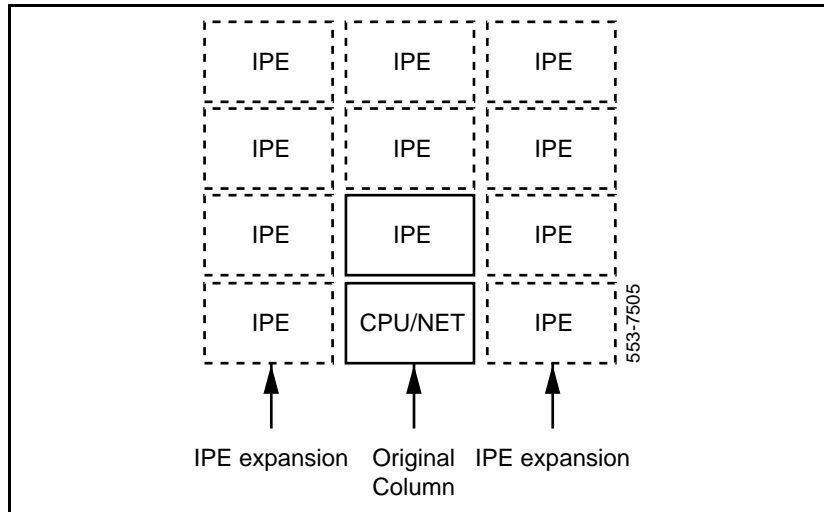

Figure 7
Three-tier Option 51C expansion

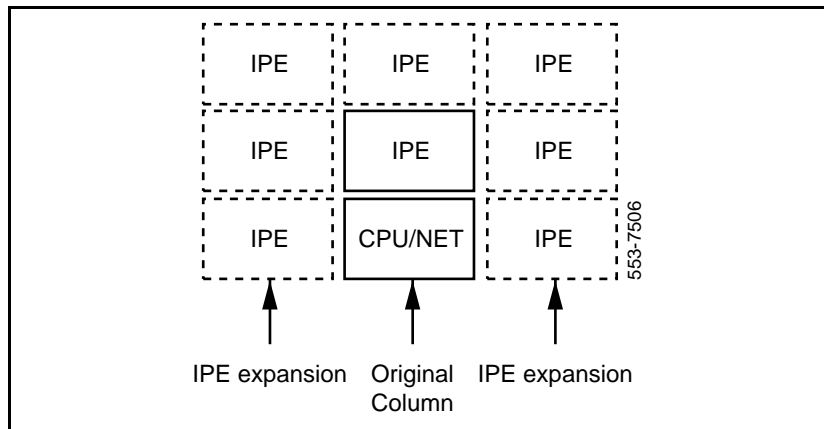

Figure 8
Option 61C migration to Option 81C

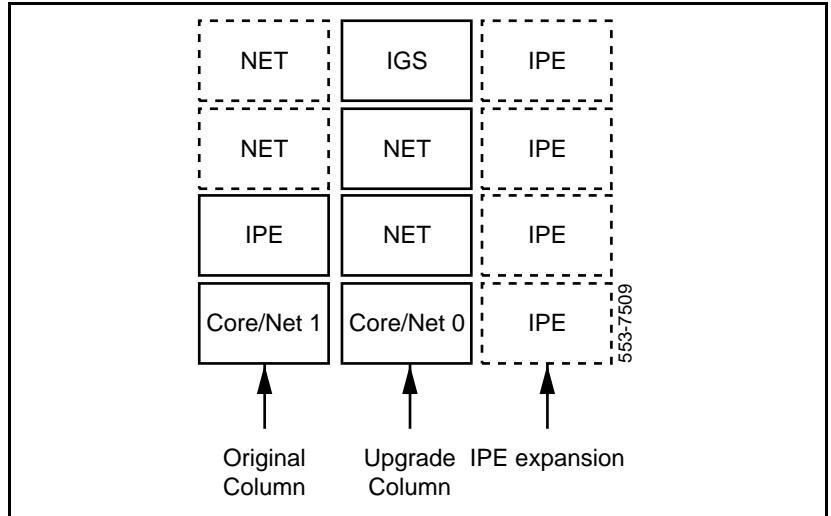
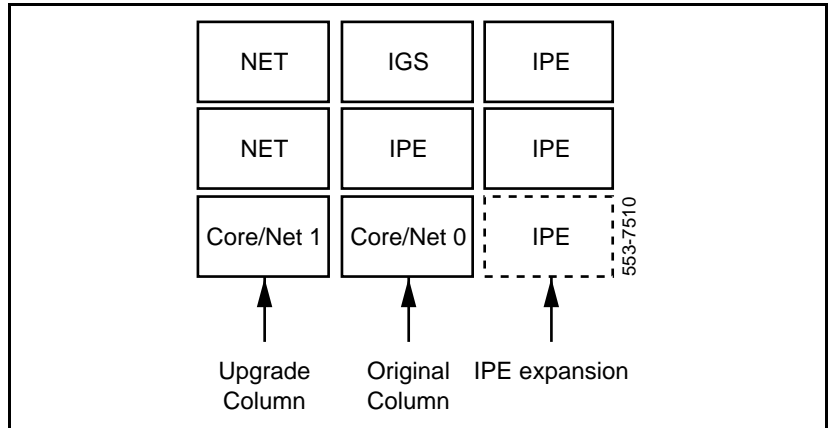

Figure 9
Three-tier Option 61C migration to Option 81C



Option 81C

The next largest system type in the Meridian 1 family is the Option 81C. Each network module supports a half group; two of these modules are required for a full group. The Option 81C supports eight network groups with Fiber Network.

Option 81C systems with IGM switching can also be upgraded to Fiber Network. Fiber Network allows the expansion of 81C systems from five Network groups to eight Network groups, a 60% increase in port and trunk capacity. The Intergroup cards and module in the existing Option 81C are replaced by a Dual Ring fiber optic network. The Fiber Network provides complete non-blocking communications between the network groups, which eliminates the incidence of busy signals for calls switched between groups.

For more information on Fiber Network upgrades, refer to the *FNF Reference Guide*

Intra-module cabling

Content list

The following are the topics in this section:

- [I/O panels 22](#)
- [Universal I/O panel 22](#)
- [Meridian 1 modules 24](#)
- [Network module 24](#)
- [Intelligent peripheral equipment module 24](#)
- [Core/Network modules 26](#)
- [Meridian Mail module 27](#)
- [Application equipment module 28](#)
- [Meridian Link module 28](#)

Cables that connect to different cards within a module as well as cables that go to the I/O panels at the rear of the module are defined as intramodule cables.

Intermodule cables, which are used to connect different modules together and to connect modules to external equipment, are discussed later in this document.

Intramodule cables are not shielded. The cable is typically round and the connector latches either bail locks or screws to prevent accidental removal. It is recommended that the faceplate connectors use a 90° cable egress, while backplane connectors should use a 180° cable egress. Either type of connector is acceptable for the I/O panels.

Cabling assignment tables are found in Appendix B.

I/O panels

Every module requires two I/O panels. These panels mount at the rear of the module. They are an integral part of the RFI shielding for the module and provide a method of bringing signals into and out of the module. The panels shown in this document, unless otherwise stated, are viewed from the rear of the module with pin 1 of the I/O connectors on top.

Universal I/O panel

The Universal I/O Connector Panel (P0715058) is used in most of the Meridian 1 modules. This I/O panel provides the following cutouts:

- 6 ports of 36-pin Telco connectors for network cables
- 2 ports of 24-pin Telco connectors for network cables
- 3 ports of 25-pin D-sub connectors for SDI/QSDI or RS-232 cables
- 3 ports of 15-pin D-sub connectors for DTI/PRI cables
- 5 ports of 9-pin D-sub connectors for XSDI cables

The 36-pin Telco-type cutouts can use an adapter to convert to 24-pin cutouts if needed for module configuration. Example: If the maximum five groups is required, three 36-pin ports can be converted with adapters to 24-pin ports, creating a total of five 24-pin ports for network connection. Figure 10 illustrates the left and right sides of the Universal I/O panels.

The I/O panel cables use bail locks and all other connectors use jack screws to prevent accidental removal.

Figure 10
Universal I/O panels

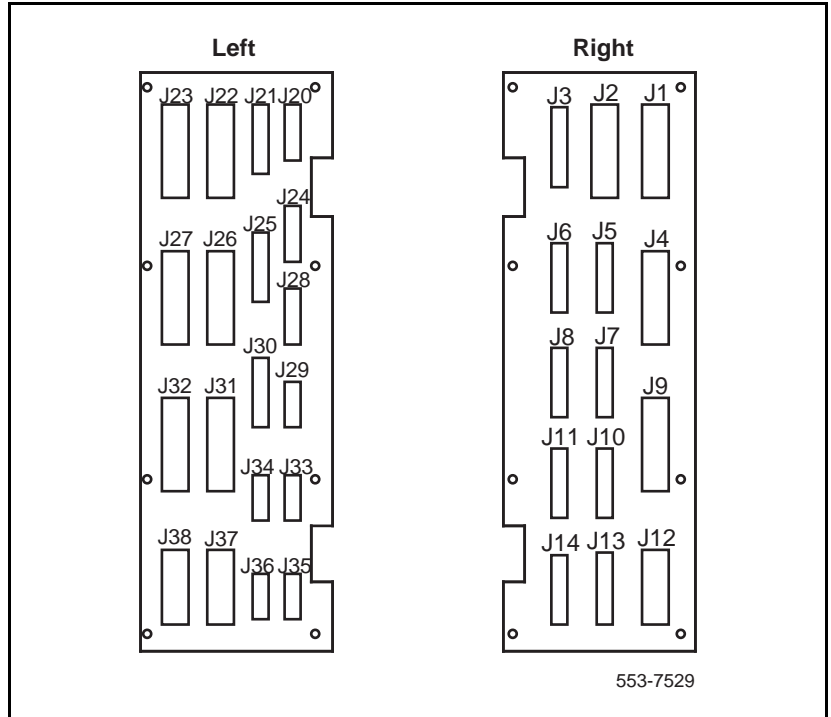

Meridian 1 modules

Network module

The NT8D35 and NT6D39 Network Modules use two identical Universal I/O panels (P0715058) as described in “Universal I/O panel” on page 22 and Figure 10.

If the I/O usage is greater than the panels can handle, overflow cables can be routed to another network module. The I/O usage is recommended as follows:

- 1 For network usage start with J1, J2, J5, J6, J9, J10, J22, J23, J26, J27, J31, and J32.
- 2 For superloop network usage start with J16, J17, J37, and J38; then use adapter P0704007 and continue with J2, J6, J10, J22, J26, and J31.
- 3 For DTI/PRI usage start with J4, J12, and J24 for the T1; for the echo canceler start with J8, J20, and J28. If the echo canceler is not used, start with J4, J8, J12, J20, J24, and J28 for the T1.
- 4 For SDI/QSDI start with J3, J7, J11, J21, J25, and J30.
- 5 For XSDI start with J13, J14, J15, J18, and J19.

Intelligent peripheral equipment module

The NT8D37 IPE Module is configured with two identical I/O panels (P0699726). These two panels contain a total of sixteen 50-pin tip and ring and four 24-pin network superloop cutouts. Since only the 16-port line cards are available at this time, only twelve of the sixteen 50-pin tip and ring cutouts are used with the rest as spares.

The cable that connects a line card to the I/O panel is the NT8D81AA Tip and Ring Cable. This cable can handle either one full line card or one full line card plus half of the next line card for a total of 24 tip and ring channels.

The cable that connects the peripheral controller card to the I/O panel is the NT8D92AB. This method of cabling is used only when the network loop is cabled externally to the module. J2 on the I/O panel is always used when cabling the network loop externally with J3, J4, and J5 configured for other traffic requirements.

Tables 4 through 15 on pages 86 through 108 give the assignments for the tip and ring cabling and Tables 16 through 19 on pages 110 through 113 give the peripheral controller card to the I/O network loop cabling. Figure 11 shows the I/O panel layout for the IPE module.

Figure 11
IPE I/O connector panels

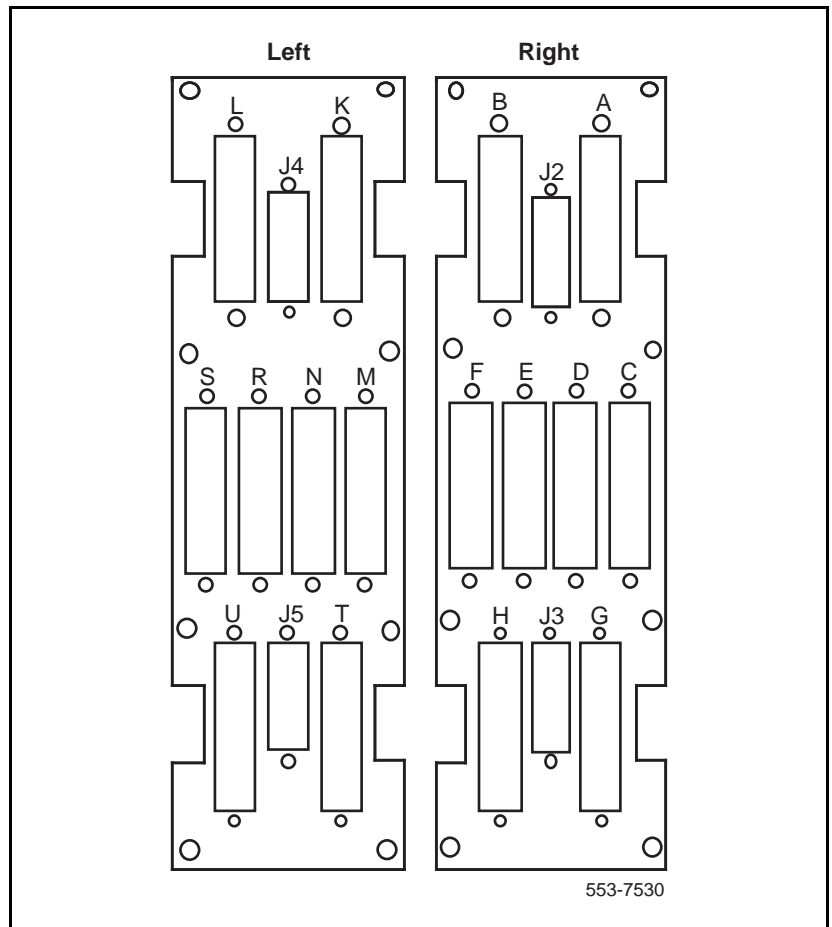

Core/Network modules

The NT5D21 Core/Network Module is used in Options 51C, 61C, and 81C. It uses two Universal I/O panels for external connections. These panels are described in “Universal I/O panel” on page 22 and Figure 10 on page 23.

For standardization, the following connections to the I/O panel cutouts are required:

1 For Core to Network Interface (CNI):

- location 9F to J1
- location 9D to J2
- location 10C to J5
- location 10A to J6
- location 10F to J9
- location 10D to J10
- location 9A to J22
- location 9C to J23
- location 8D to J26
- location 8F to J27

2 For Call Processor (CP):

- RS-232 DTE Port to J21
- RS-232 DCE Port to J25

3 Clock Controller (CC):

- connector J1 to J33
- connector J2 to J29.
- connector J3 to J32.

Meridian Mail module

The NT6D44 Meridian Mail Module uses two different I/O panels. The left I/O panel is P0704822. The right I/O panel is a blank (P0704005). Only the CSL, CRT, NVP0, and NVP1 cutouts are used, as shown in Figure 12.

Cabling to Meridian Mail, the network loop, and Command Status Link (CSL) is done through the left I/O panel only.

Figure 12
Meridian Mail module I/O panels

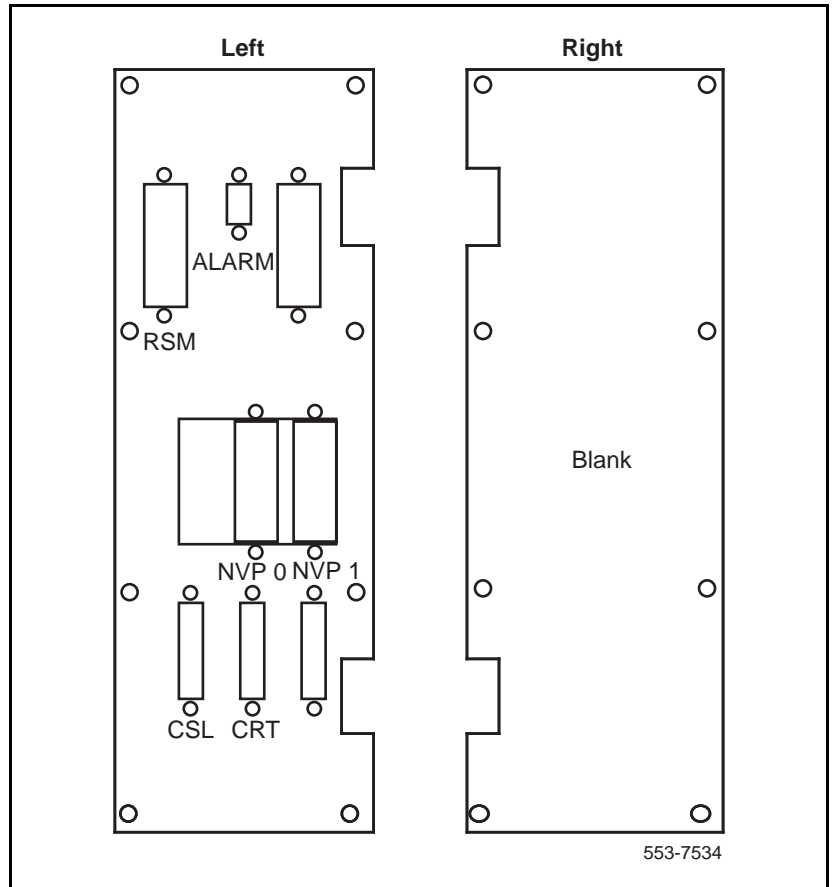

Application equipment module

The NT7D18 Application Equipment (AE) Module is the basic platform for the VMEbus-based auxiliary processor equipment. The AE supports two application modules. Only mechanical supports and an MPDU are supplied with the AE. No backplane, power supply, or I/O panel is included with the AE UEM; these are provided with the application modules that reside in the AE module. When an application module occupies only half the AE module, the I/O panel (P0704005) in the other half is not occupied.

The left side I/O panel in the AE UEM contains the system monitor connectors for cable NT8D46AA mounted on a PCB. Because of this, the entire I/O panel is not available for connectors. Additionally, because the application modules must be repaired in the field, the I/O panel must be removable. To solve this problem, a removable insert panel fits inside the I/O panel.

Meridian Link module

The Meridian Link module provides the I/O panel insert (P0726322) required for the left side position in the AE module. Outputs for the console, SDI port, and MDF are brought out on J7, J8, and J9. Outputs for the ESDI port and host computer are brought out on J2 and J3. Table 22 on page 116 gives the cabling assignments and Figure 13 shows the I/O connector panel insert.

Figure 13
Meridian Link I/O panel

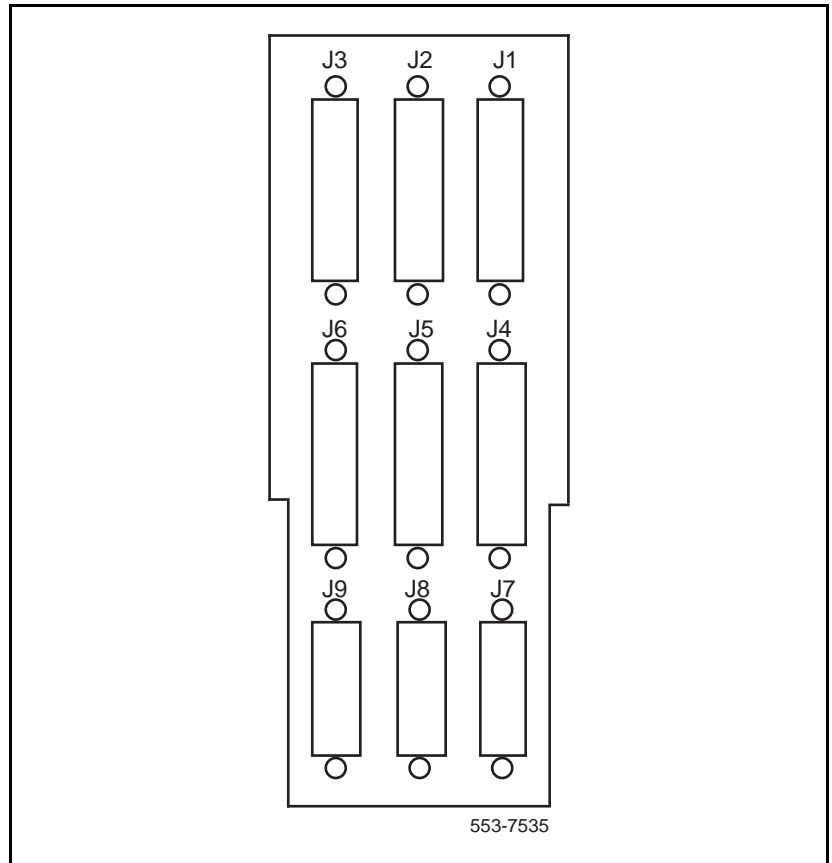

Inter-module internal cabling

Content list

The following are the topics in this section:

- [Network to network 31](#)
- [Half-group network 32](#)
- [Core/Network Module to Core/Network Module 33](#)
- [Network to IPE 33](#)

Cables that are routed internally between modules are intermediate cables. They are used primarily for interconnecting Core/Network to Core/Network, Core/Network to network, network to IPE, and the system monitor to the different modules.

Cabling assignment tables are found in Appendix B.

Network to network

Cabling between NT8D35 Network Modules interconnects the two half groups together to build an Option81C full-network group. The first full-group in Option 81C is located in the Core/Network Module together with the CPU. The maximum length of the interconnecting cables between the two modules is 2 feet. The two half-group network modules must therefore be stacked one on top of the other. The cables are then routed from the backplane of one module to the backplane of the other through the vertical holes in the rear horizontal cable trough of the modules. Table 20, “Cabling between two NT8D35 XNE Modules,” on page 114 gives the cabling assignment for this configuration.

In the case of an Option 81C upgraded from an SL-1 type cabinet (QCA55), all network group shelves have to be relocated in the Meridian 1 modules when the core/network modules and expanded network group are installed.

For Option 81C systems equipped with Fiber Network, up to eight Network groups can be configured together using the Fiber Junctor Interface (FIJI) and CNI or CNI-3 cards. Fiber Network supports “mixed network” systems that include a combination of SL-1 cabinets and Network modules. Such “mixed networks” are *not* supported on IGS/IGM-based systems.

For non-Fiber Network systems, cabling more than one network group together into a multi-group configuration requires the use of intergroup switch (IGS) cards and the NT8D36AA InterGroup Module. Table 21, “Network to junctor cabling,” on page 115 provides the cabling assignment.

Half-group network

The Core/Network module interfaces the Core and the network together over the backplane. There are no interface cables required between these two subsystems when configured as a half-group Option 51C.

Core/Network Module to Core/Network Module

The core/network module can access up to eight full-group networks in the Option 81C. Each group is configured exactly the same way with device address switches on the 3PE defining group 0 to group 7. Group 0 is located in the Core/Network Modules. The network modules are cabled as full groups, as defined in the “Network to network” on page 31.

Figure 14
Option 81C basic configuration

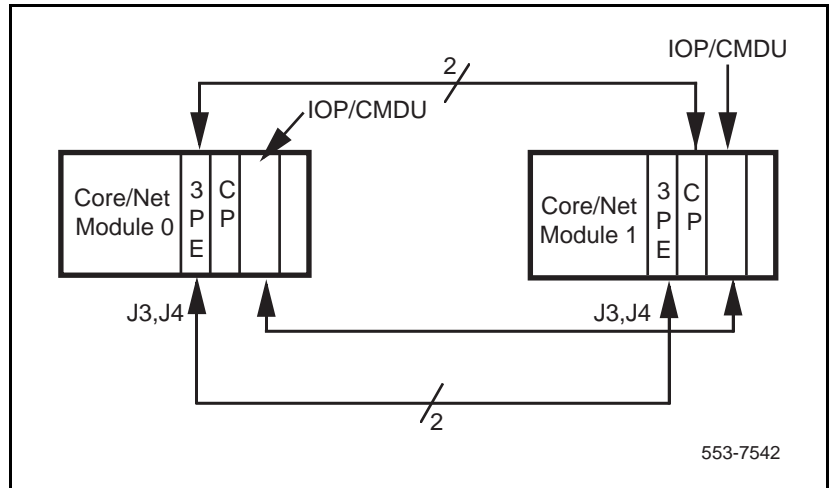

Network to IPE

Cabling of network to IPE peripherals connects to the backplane in the IPE module instead of the faceplate of the DLB as in the PE module.

System monitor cabling

The NT8D22 System Monitor is used to monitor the temperature, power supplies, and blower unit in a column. A series of daisy-chained flat-ribbon cables between each module is used to connect the power supplies and the top cap thermal sensors to the system monitor located in the pedestal. The flat cable is routed through the square holes in the rear horizontal cable trough. Figure 15 shows the cabling of the system monitor in a column.

Connecting the system monitor to an SDI port is done by replacing one of the daisy-chained cables with a special cable that also plugs into an SDI faceplate port or an XSDI paddleboard port. Figure 16 shows the system monitor cabled to an SDI and Figure 17 shows the system monitor cabled to an XSDI port.

In a dual-CPU configuration where the CPUs are in different columns, as in Option 81C, a special cable is required to connect the CPU status between the two CPUs to the system monitor. See Figure 18 for this arrangement.

Figure 15
System monitor module to module cabling

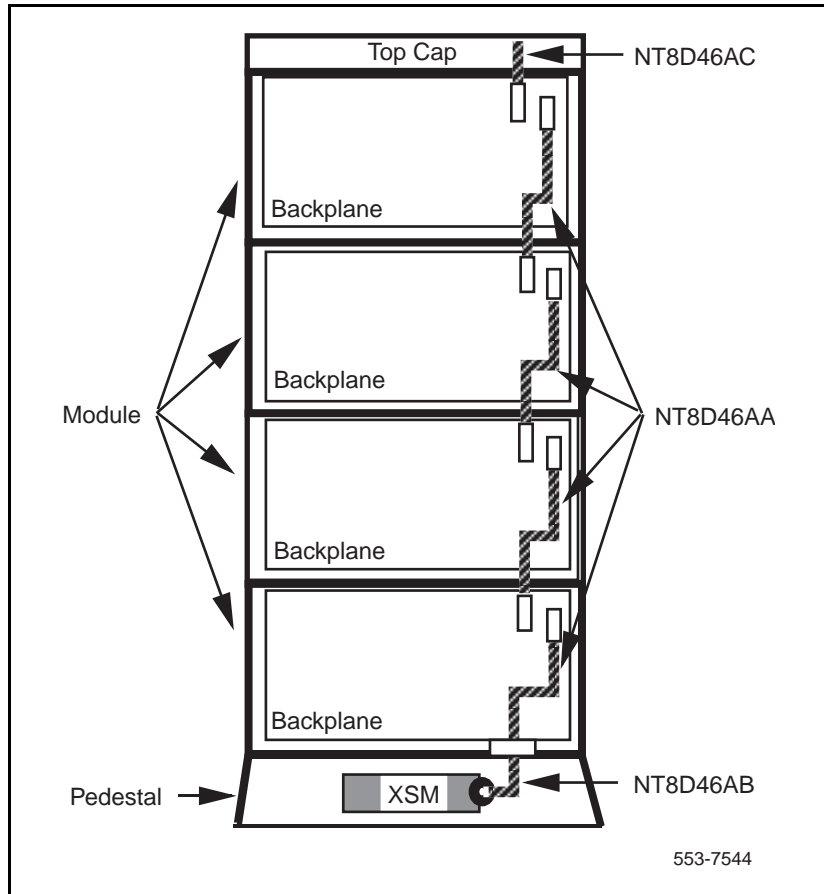

Figure 16
System monitor to SDI cabling method

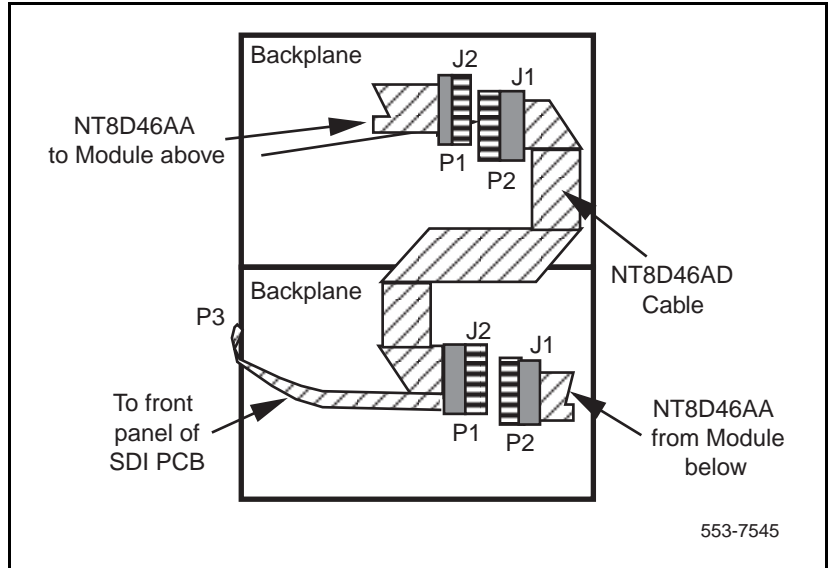

Figure 17
System monitor to XSDI cabling method

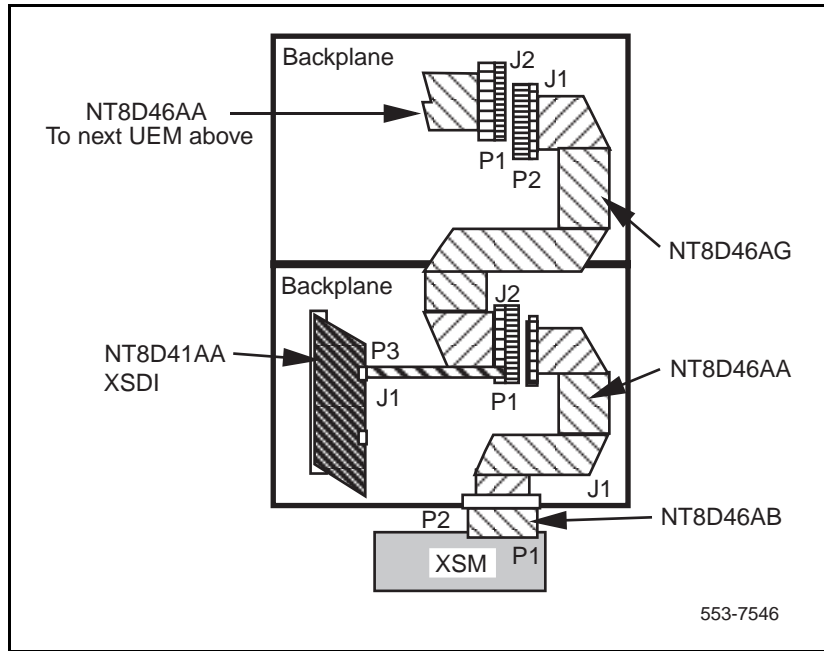
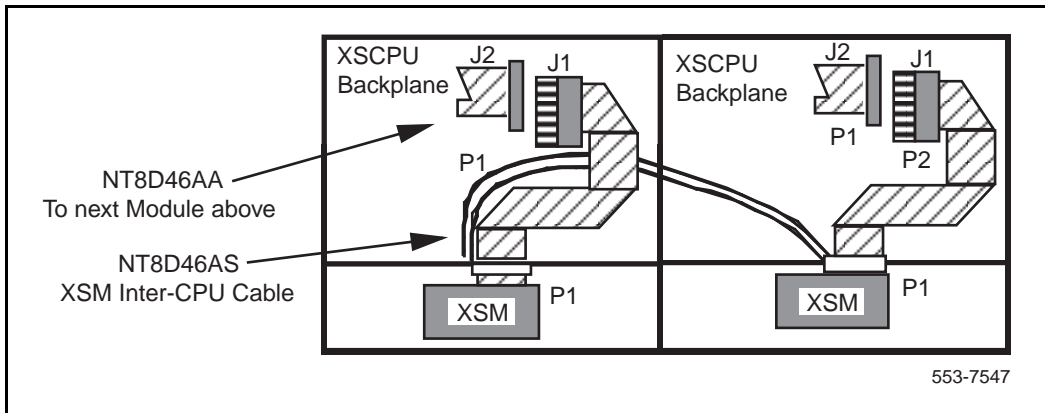

Figure 18
System monitor inter-CPU cabling



Inter-module external cabling

Cabling in this category consists of routing network loops and superloops between two physically isolated cabinets, cabling to Meridian Mail, cabling system monitor to system monitor in a multi-column system, and connecting the system monitor to the MDF and UPS system.

The network equipment is in either a Meridian 1 module or an SL-1 cabinet. IPE is only be in Meridian 1 modules. The external cables are shielded to prevent possible EMI/RFI caused by the network loop signals.

Note: Fiber Network supports “mixed network” systems that include a combination of SL-1 cabinets and Network modules.

The network cables must exit through a module I/O panel and connect to another I/O panel on a Meridian 1 module or an I/O panel on an SL-1 cabinet. In either packaging configuration, module to module or module to cabinets, the intermodule cables are the same. Only where the cables connect is different. Figures 19, 20, and 21 show typical cabling configurations.

Figure 19
Module to module intercabinet cabling

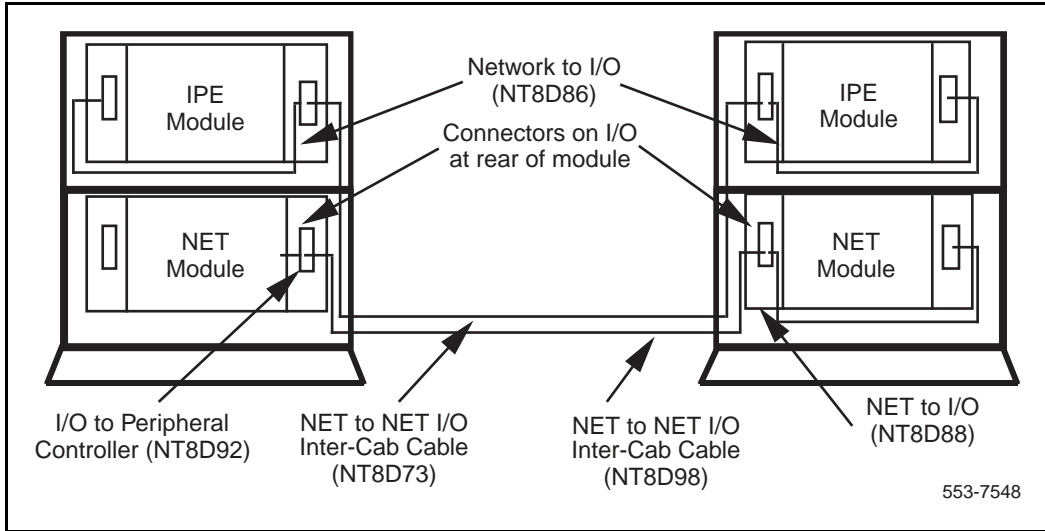

Figure 20
Cabinet to module inter-cabinet cabling

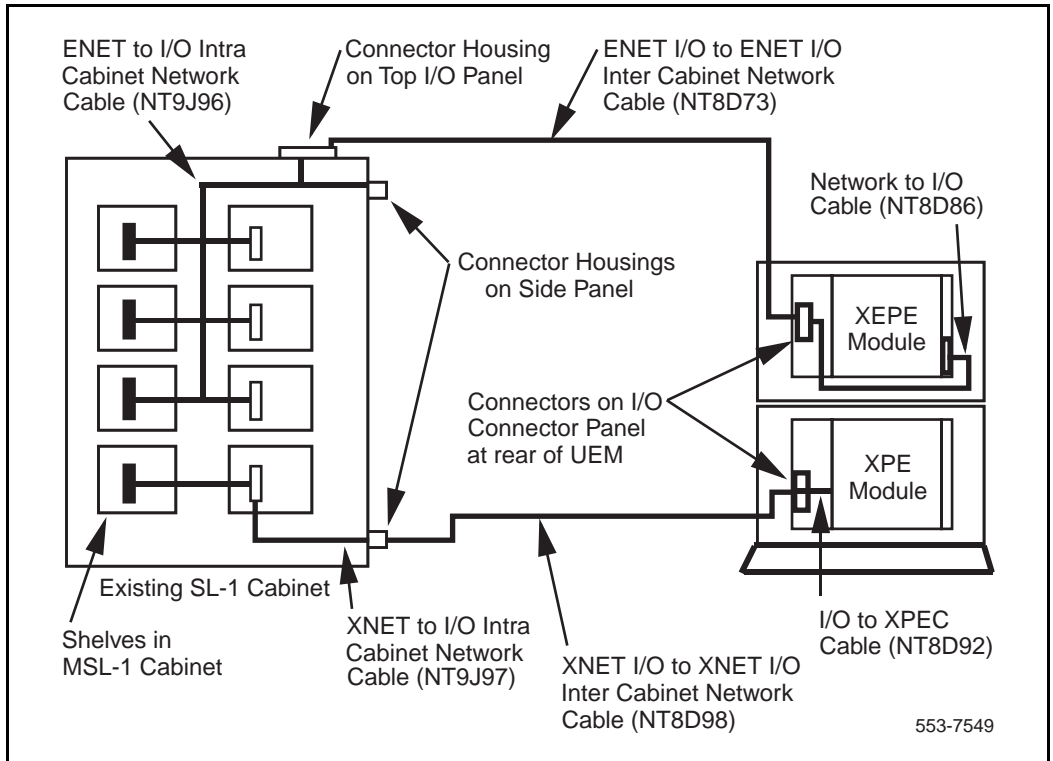
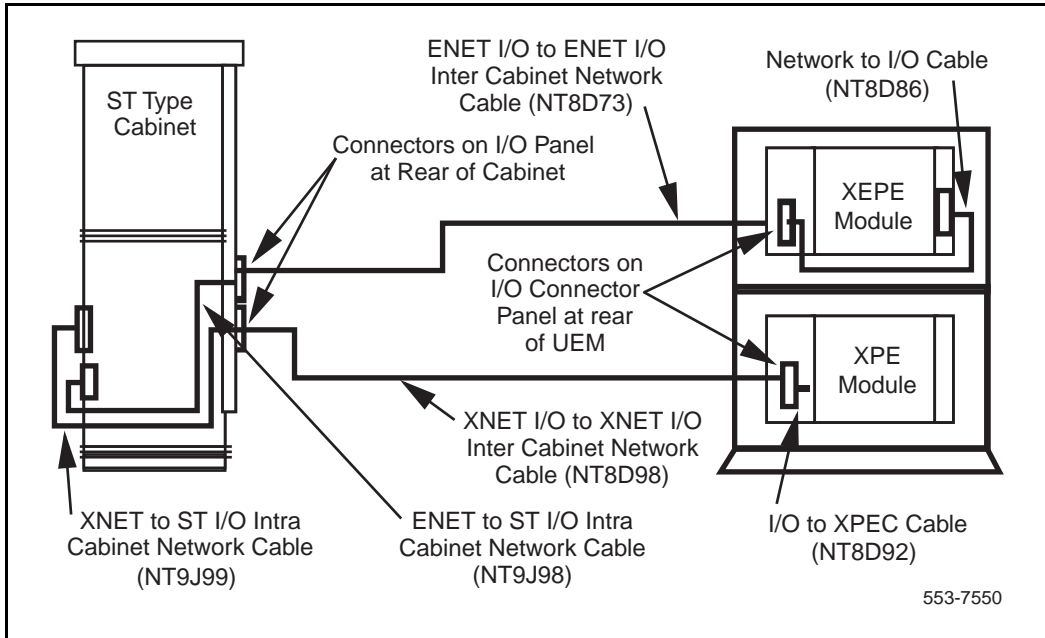
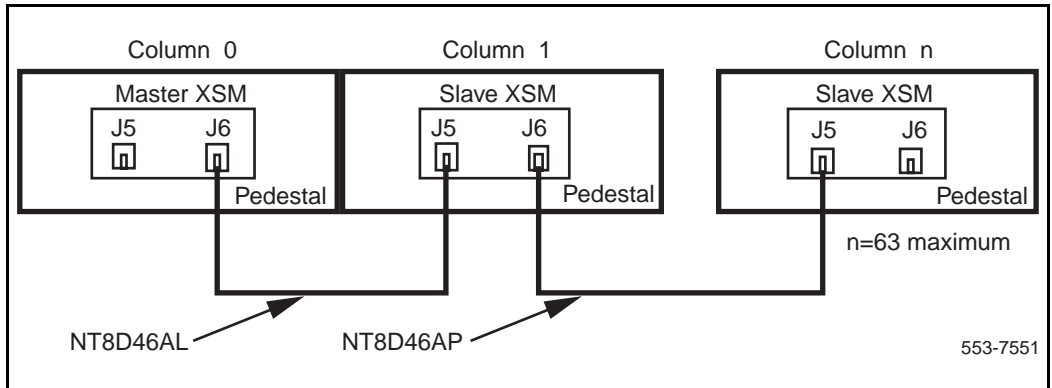

Figure 21
ST to module intercabinet cabling



Cabling between system monitors in a multi-column system requires the use of a single cable. The cabling is done in a daisy-chain fashion with the master system monitor at the beginning of the chain. The order in which each system monitor is cabled is not important. However, the address of each slave system monitor must be unique and there cannot be any gaps in the slave numbering. Figure 22 shows a typical cabling scheme between columns.

Figure 22
System monitor to system monitor serial link cabling



The system monitor can be cabled to the MDF to provide power fail transfer control or additional alarms. The cable used is the NT8D46BH, EH, or DH and it is plugged into J3 on the system monitor. With the same J3 connector, the system monitor can be used with a variety of cables for upgrading SL-1 type systems to the Meridian 1 Options.

The system monitor can also monitor and control an AC-powered UPS. Connector J4 is used for this interface. Three cables are available for connecting to a UPS: NT8D46AQ, NT8D46AJ, and NT8D46AU.

The system monitor can also work with DC power supplies. Connector J4 is used to monitor the rectifiers. Cables required depend on which battery distribution box is used. The QBL15 configuration uses one NT8D46AT per QBL15 as well as an NT6D54AA for a field wiring kit. The QCA13 uses an NT8D46AV and the QBL12 uses an NT8D46AW.

Network to Meridian Mail cabling

Cabling the Meridian Mail module is done only through the I/O panels. For a minimum configuration of one Meridian Mail module, two external cables are required. One is an NT8D73xx network loop cable and the other is an NTND91AA/AB Command Status Link (CSL) cable. Another CSL cable can be used to connect the Meridian Mail module to a local terminal. When more than one Meridian Mail module is configured, Meridian Mail modules must be daisy-chained together with an NT6D4415 DVS Daisy-Chain Cable. Only the primary node Meridian Mail module has CRT, CSL, and network connections. All other Meridian Mail modules have a network loop connection and the DVS daisy-chain cable. Figure 23 shows the cabling of a Meridian Mail module to a network module.

Figure 23
Meridian Mail module cabling

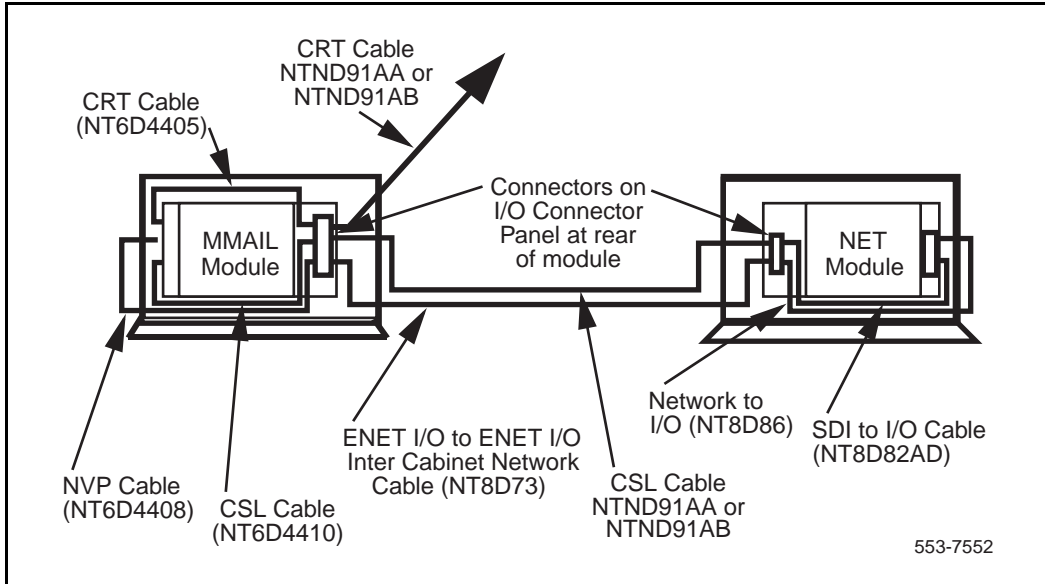

Module to external equipment cabling

Cabling in this category connects the module I/O panel to any external equipment such as terminals and printers. Figure 24 shows the cabling required for the QSDI and Figure 25 shows the cabling required for the XSDI.

Figure 24
Side view of QSDI module cabling

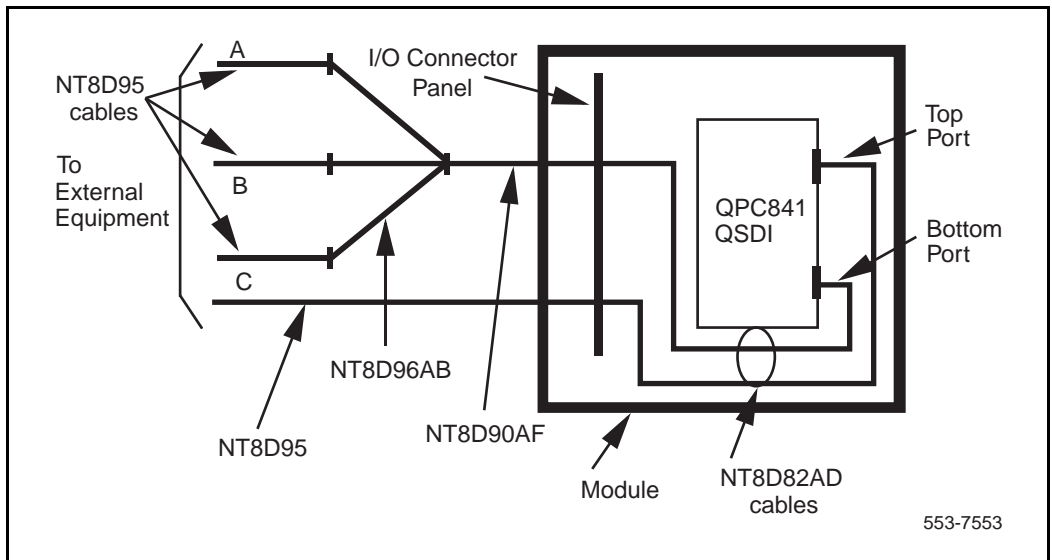

In Figure 24 the bottom port of the QSDI contains three separate RS-232 channels, which are split by the NT8D96AB cable. In order to prevent cable congestion in the rear of the column, the NT8D90AF cable is used to split the ports outside the column. When congestion is not a problem the NT8D90AF cable can be eliminated and the NT8D96AB cable can be connected directly to the I/O panel.

Figure 25
Option 21/21E SDI and XSDI cabling

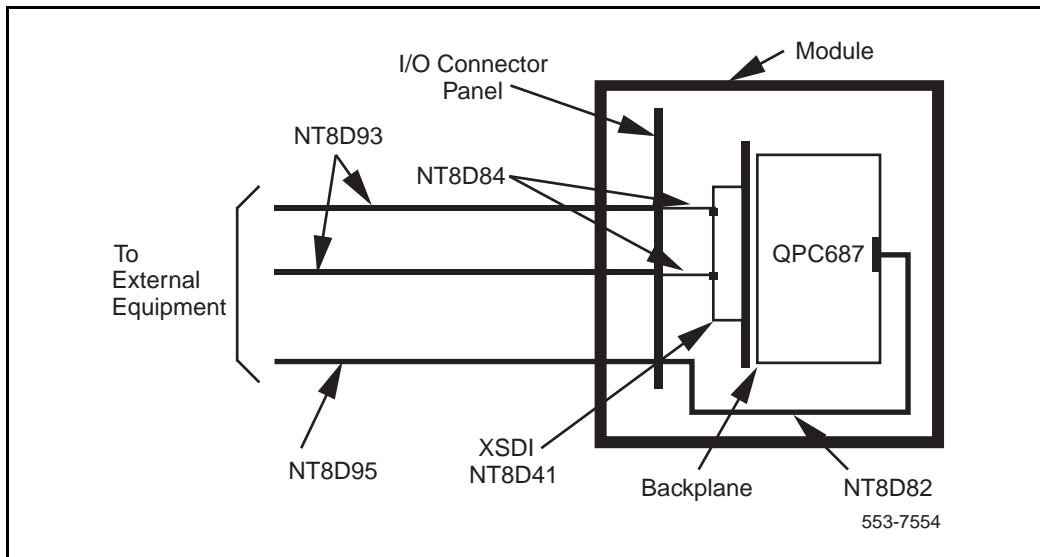

System upgrade to Meridian 1

Content list

The following are the topics in this section:

- [Upgrade to Option 81C 49](#)
- [Upgrade from SL-1 to Meridian 1 system 55](#)
- [Upgrade from an SL-1 NT or XT 55](#)
- [Upgrade from an SL-1 ST or RT 57](#)

Upgrade to Option 81C

To upgrade from Options 71 or 81 to Option 81C, NT8D34 CPU Modules or NT6D60 Core Modules are replaced by NT5D21 Core/Network Modules with their appropriate circuit cards. The arrangements for other modules in the system remain the same as in Option 71 or 81.

To upgrade from an Option 61 or Option 61C with NT9D11 Core/Network Modules, to an Option 81C, two NT5D21 Core/Network Modules replace the original system common equipment modules, and an intergroup module and two network modules are added to create the one network group required. Additional modules can be added to expand the number of network groups and the IPE.

When upgrading from 61C that uses NT5D21 Core/Network Modules to Option 81C additional CNI cards, and two Fiber Network modules are added to create the one network group required. Additional modules can be added to expand the number of network groups and the IPE

Figure 26 illustrates the typical upgrade to an Option 81C full five-group network from either Option 61, 61C, 71, or Option 81.

Figure 26
Option 81C upgraded from Option 61, 61C (NT9D11), 71, or 81

NET 4 Shelf 1	IGS	IPE	MM	IPE	553-7555
NET 4 Shelf 0	NET 2 Shelf 1	NET 1 Shelf 1	MM	IPE	
NET 3 Shelf 1	NET 2 Shelf 0	NET 1 Shelf 0	IPE	IPE	
NET 3 Shelf 0	Core/Net 0 Group 0	Core/Net 1 Group 0	IPE	AEM	

Figure 27 illustrates the typical upgrade to an Option 81C full eight-group Fiber Network (supported on release 25 and later).

To upgrade from a current SL-1 XT system to an IGS/IGM-based Option 81C, without full five-group network expansion, two adjacent Meridian 1 columns are added. These two columns contain two core/network modules and an IPE module. For the current SL-1, which requires network expansion beyond its existing cabinets (QCA55 and QCA108), two Meridian 1 columns are added. These columns contain two core/network modules. All existing network group cards have to be relocated into these two columns, and additional network modules have to be added to reach the required number of network groups. Also, a junctor module and IPE modules are added into these two columns.

Figure 27
Option 81C Fiber Network upgrade

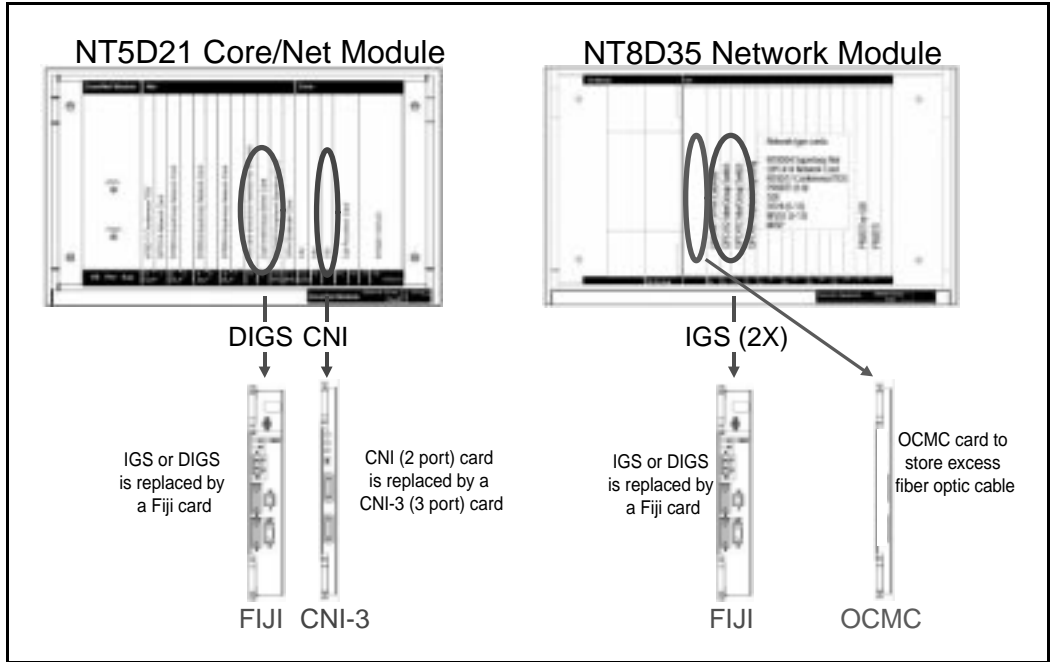

Table 1 shows the cables required to upgrade to an Option 81C.

Table 1
Cables required to upgrade to an IGS/IGM Option 81C

Upgrade	Cables	Quantity	Description
Module System	NTND11AA	2 per system	CMB to CMB cable
	NTND13AC	1 per system	SCSI I/O Panel to I/O Panel Cable
	NTND14xx	2 per half group	CNI to 3PE cable
	NTND89AA	2 per system	RS-232 cable
	NT7D90AA	2 per system	Ethernet to I/O Panel cable
	NT8D80AZ	1 per system	3PE to 3PE cable
	NT8D74AE/AF	2 per system	Clock to Junctor cable
Cabinet System	NTND11AA	2 per system	CMB to CMB cable
	NTND13AC	1 per system	SCSI I/O Panel to I/O Panel Cable
	NTND89AA	2 per system	RS-232 cable
	NT7D90AA	2 per system	Ethernet to I/O Panel cable
	NT8D80AZ	1 per system	3PE to 3PE cable
	NT8D76AC	2 per system	Clock to I/O Panel cable
	NTND94AA	2 per half group	CNI to I/O Panel cable

Figure 28 shows the interconnection between Meridian 1 columns with core/network modules and the existing SL-1 cabinet.

Figure 28
IGS/IGM based Option 81C upgraded from an SL-1 system

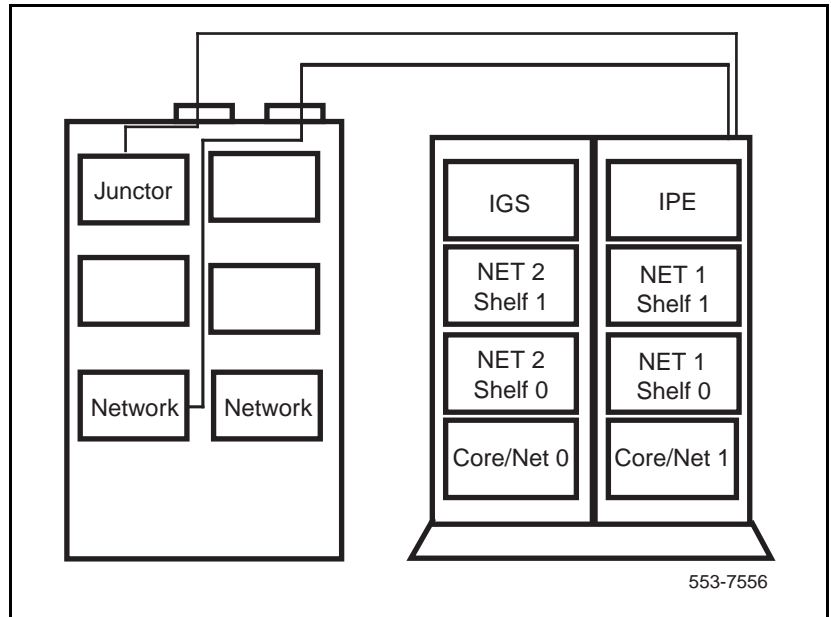

To upgrade from an XL-1 XT system to an Option 81C with Fiber Network, two adjacent Core/Net modules are added. Fiber Network supports “mixed networks” systems that include a combination of SL-1 cabinets and Network modules. Such “mixed networks” are not supported on IGS/IGM based systems.

Refer to Table 2 for the cables required to upgrade to an Option 81C with Fiber Network.

Table 2
Cables required to upgrade to an Option 81C with Fiber Network

Cable type	Quantity	Part number	Description
Fiber Ring cable	1 per FIJI card	NTRC48AA	6 ft. fiber optic cable
		NTRC48BA	10 ft. fiber optic cable
		NTRC48CA	12 ft. fiber optic cable
		NTRC48DA	14 ft. fiber optic cable
		NTRC48EA	19 ft. fiber optic cable
		NTRC48FA	26 ft. fiber optic cable
		NTRC48GA	32 ft. fiber optic cable
		NTRC48HA	50 ft. fiber optic cable
CNI to 3PE cable	2 per CNI or CNI-3 card	NTND14	CNI to 3PE backplane cable used with both CNI and CNI-3 card. Two cables are required per configured port.
CNI-3 to 3PE cable	2 per CNI-3 card	NT9D89CA	8 ft. cable used when faceplate port "C" is configured.
		NT9D89DA	10 ft.
		NT9D89EA	12 ft.
		NT9D89FA	25 ft.
		NT9D89GA	50 ft.
Clock to FIJI	2 per system	NTRC46AA	4 ft.-13.5 ft.*
		NTRC46BA	5.5 ft. - 8 ft.*
		NTRC46CA	22 ft.-22 ft.*

Table 2
Cables required to upgrade to an Option 81C with Fiber Network

Cable type	Quantity	Part number	Description
Clock to Clock	1 per system	NTRC49AA	6 ft.
		NTRC49BA	20 ft.
FIJI to FIJI Sync	1 per network group	NTRC47AA	5 ft.
* indicates the lengths of the two "Y" terminations.			

Upgrade from SL-1 to Meridian 1 system

When a Meridian 1 system Option 51C, 61C, or 81C is colocated with an SL-1 type, cabling between the systems is the same as described in the previous sections between CPU, network, PE, and IPE modules. However, the system monitor has to interface with the old power monitor circuit cards, such as QPC84, QPC173, QPC704 or QPC813 that require additional cables in the upgrades.

Upgrade from an SL-1 NT or XT

For an upgrade from an SL-1 NT or XT, whether the CPUs are located in the Meridian 1 column to create an Option 61C or 81C, or the CPUs remain in the SL-1 cabinet (PE expansion), the system monitor requires the cable NT8D46BH to connect from the J3 connector to the MDF.

At the MDF, the cable P10 is used to connect the SL-1 power monitor card (QPC84 or QPC173) using the NT8D46BH. Depending on the CPU location and the functional configuration between the Meridian 1 and the SL-1 XT or NT system, the installer is required to connect the appropriate leads of the P10 and NT8D46BH cables between two systems in the MDF. Through these connections, the system monitor interfaces with the following power monitor cards:

- SL-1 NT, Cabinet QCA58: QPC84
- SL-1, PE Cabinet QCA74: QPC84
- SL-1 XT, Cabinet QCA55: QCA173

Figure 29 shows the system monitor cabling from the SL-1 NT or XT to the Meridian 1 column via the MDF.

Figure 29
Option 51C upgraded from an SL-1 NT or RT system

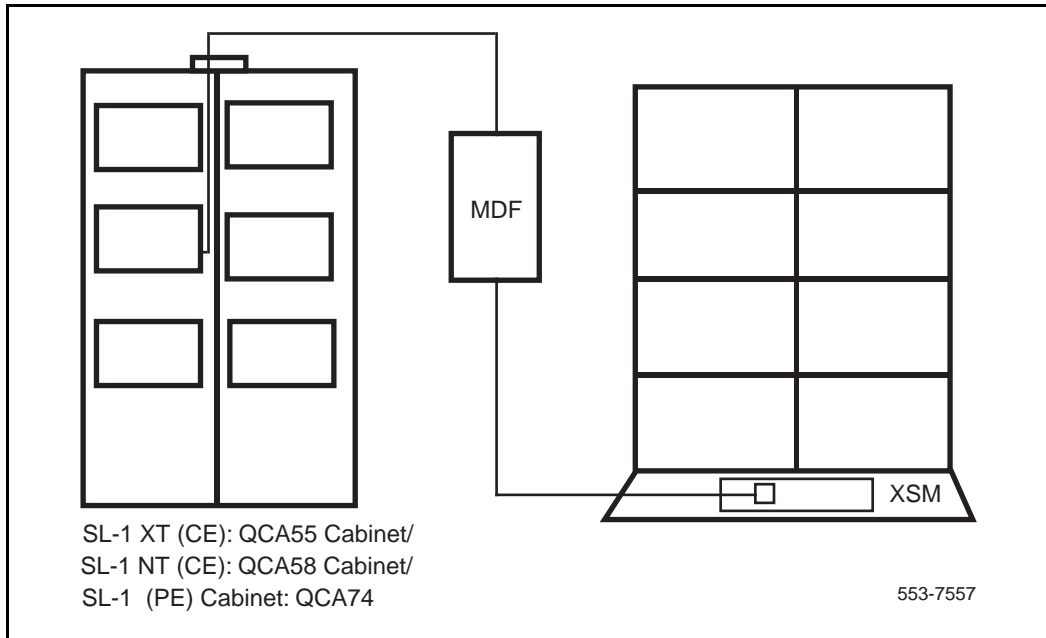

Upgrade from an SL-1 ST or RT

For an upgrade from an SL-1 ST or RT, whether the CPU is located in the Meridian 1 column to create the system Option 51C, or the CPU remains in the SL-1 cabinet (PE expansion), the system monitor requires a variety of cables to connect from the J3 connector to the MDF.

Depending on the CPU location and the functional configuration between the Meridian 1 and the SL-1 ST or RT system, the installer is required to connect the appropriate cables between the systems. In this configuration, the system monitor interfaces with the following power monitor cards:

- SL-1 ST, Cabinet QCA136: QPC704
- SL-1, PE Cabinet QCA137: QPC704
- SL-1 RT, Cabinet QCA147: QPC813

Figure 30 shows the system monitor cabling from the SL-1 ST or RT to the Meridian 1 column.

Figure 30
Option 51C upgraded from an SL-1 ST or RT system

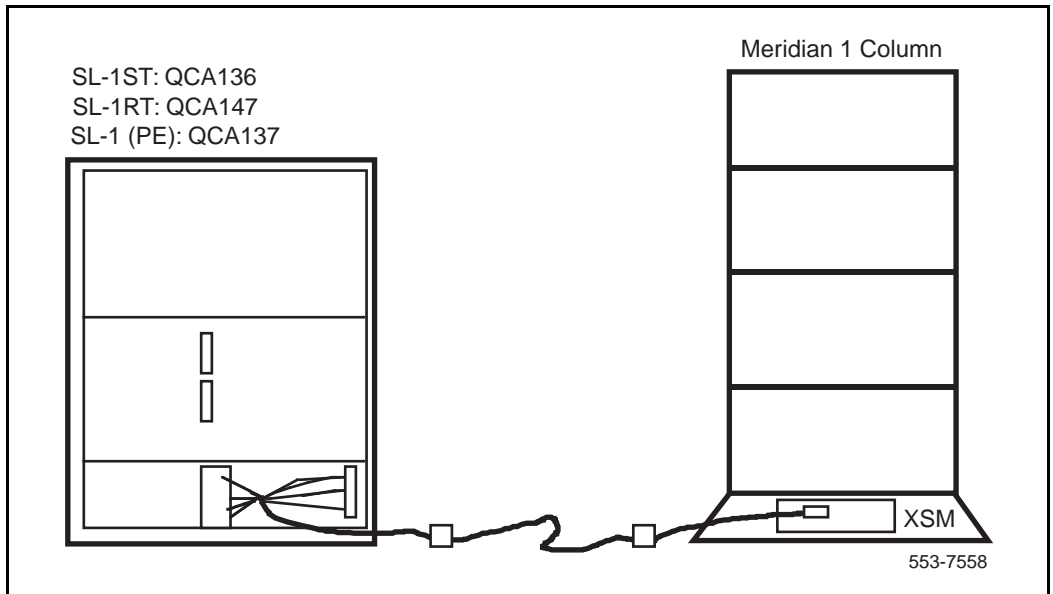

Table 3 shows 12 upgrade configurations and the required cables from current SL-1 ST and RT to the Meridian 1.

Table 3
Twelve upgrade configurations and required cables (Part 1 of 2)

Configuration	Cabinets	CPU location	Cables
SL-1 ST to M-1	QCA136 (CE) & Meridian 1 (PE)	QCA136	NT8D46AY QCAD309
SL-1 ST to M-1	QCA136 (PE) & Meridian 1 (CE)	Meridian 1	NT8D46AX NT8D46BA
SL-1 (PE) to M-1	QCA137 (PE) & Meridian 1 (CE)	Meridian 1	NT8D46AX
SL-1 ST to M-1	QCA136 (PE), QCA137 (PE) & Meridian 1 (CE)	QCA136	NT8D46BC NT8D46BE NT8D46BM
SL-1 ST to M-1	QCA136 (PE), QCA137 (PE) & Meridian 1 (CE)	Meridian 1	NT8D46BB NT8D46BC NT8D46BD NT8D46BE
SL-1 RT to M-1	QCA147 (CE) & Meridian 1 (PE)	QCA147	NT8D46AY
SL-1 RT to M-1	QCA147 (PE) & Meridian 1 (CE)	Meridian 1	NT8D46AX NT8D46BG
SL-1 RT to M-1	QCA147 (CE), QCA137 (PE) & Meridian 1 (CE)	QCA147	NT8D46CH
SL-1 RT to M-1	QCA147 (PE), QCA137 (PE) & Meridian 1 (CE)	Meridian 1	NT8D46BC NT8D46BD NT8D46BE NT8D46BJ

Note: In all configurations the cables NT8D46BF and NT8D46BH are used when extending the alarm connection to the MDF.

Table 3
Twelve upgrade configurations and required cables (Part 2 of 2)

Configuration	Cabinets	CPU location	Cables
SL-1 ST to M-1	QCA137 (PE), QCA137 (PE) & Meridian 1 (CE)	Meridian 1	NT8D46BC NT8D46BE NT8D46BL
SL-1 RT to M-1	QCA147 (PE), QCA137 (PE), QCA137 (PE) & Meridian 1 (PE)	QCA147	NT8D46BC NT8D46BE NT8D46BL
SL-1 RT to M-1	QCA147 (PE), QCA1E7 (PE), QCA137 (PE) & Meridian 1 (CE)	Meridian 1	NT8D46BC NT8D46BD NT8D46BE NT8D46BJ
Note: In all configurations the cables NT8D46BF and NT8D46BH are used when extending the alarm connection to the MDF.			

Appendix A: Internal and External Signaling Cables

Appendix A contains a list of all known internal and external signaling cables used in the Meridian 1 Options 51C, 61C, and 81C. The cable Product Engineering Code (PEC), CPC code, and length are listed for easy reference.

A0660711 25DB Adapter Cable

PEC	CPC	Length	Description
None	A0660711	2 in.	M25DB-F25DB, Round
Engineering Code: CRP14MADAPT01			

QCAD328 DCHI Interface Cable

PEC	CPC	Length	Description
QCAD329A	A0341116	6 ft	M25DB-M15DB, Round
QCAD328B	A0356843	18 ft	M25DB-M15DB, Round
QCAD328C	A0363996	35 ft	M25DB-M15DB, Round
QCAD328D	A0363997	50 ft	M25DB-M15DB, Round

NT1R03 Shielded 4 Port with Ethernet Cable

PEC	CPC	Length	Description
NT1R03AA	A0400295	31 in.	F50Telco-(5)F15DB, Round

NT1R03 Shielded 4 Port Cable

PEC	CPC	Length	Description
NT1R03BA	A0400297	30 in.	F50Telco-(4)F25DB, Round

NT1R03 Shielded LAM Extension Cable

PEC	CPC	Length	Description
NT1R03CA	A0401483	2 ft	M50Telco-F50Telco, Round

NT1R03 25DB M/M Extension Cable

PEC	CPC	Length	Description
NT1R03DB	A0402335	2 ft	M25DB-M25DB, Round
NT1R03DC	A0402336	4 ft	M25DB-M25DB, Round
NT1R03DF	A0402337	10 ft	M25DB-M25DB, Round
NT1R03DP	A0402338	25 ft	M25DB-M25DB, Round
NT1R03DV	A0402339	45 ft	M25DB-M25DB, Round

NT1R03 25DB M/F Extension Cable

PEC	CPC	Length	Description
NT1R03EB	A0402330	2 ft	M25DB-F25DB, Round
NT1R03EC	A0402331	4 ft	M25DB-F25DB, Round
NT1R03EF	A0402332	10 ft	M25DB-F25DB, Round
NT1R03EP	A0402333	25 ft	M25DB-F25DB, Round
NT1R03EV	A0402334	45 ft	M25DB-F25DB, Round

NT1R03 Max to IPE Modem Cable

PEC	CPC	Length	Description
NT1R03HF	A0402669	10 ft	M25DB-M25DB, Round

NT1R04 Clock Controller to I/O Panel Cable

PEC	CPC	Length	Description
NT1R04AA	A0401042	4 ft	M50Telco-F50Telco, Round

NT1R05 Intercabinet Module Cable

PEC	CPC	Length	Description
NT1R05AA	A0401044	16 ft	F9DB-F9DB, Round

NT4R20 RSM Adapter Cable

PEC	CPC	Length	Description
NT4R20AA	A0358325	25 ft	M50Telco-(3)F25DB, Round

NT5D19AA Maintenance Cable

PEC	CPC	Length	Description
NT5D19AA	A0660348	3 ft	Round

NT5D50AA DBX Ribbon Cable

PEC	CPC	Length	Description
NT5D50AA	A0684808	3 ft	Ribbon, SCSI extension

NT6D4405 CRT Cable

PEC	CPC	Length	Description
NT6D4405	A0363745	33 in.	F25DB-M9DB, Ribbon

NT6D4406 RSM Cable

PEC	CPC	Length	Description
NT6D4406	A0363813	32 in.	M50-F50/M9, Headers, Ribbon

NT6D4407 GSP Cable

PEC	CPC	Length	Description
NT6D4407	A0363746		F36Telco-(4)9DB, Ribbon

NT6D4408 NVP Cable

PEC	CPC	Length	Description
NT6D4408	A0363747	33 in.	(2)F36Telco-(4)2x25Socket, Ribbon

NT6D4410 CSL Cable

PEC	CPC	Length	Description
NT6D4410	A0363749	33 in.	M25DB-F25DB, Ribbon

NT6D4411 DVS Bus Node to Node Cable

PEC	CPC	Length	Description
NT6D4411	A0367987	33 in.	2x30-2x30Socket, Ribbon

NT6D4412 DVS Bus Internal Cable

PEC	CPC	Length	Description
NT6D4412	A0368070	8 in.	F60-F60Socket, Ribbon

NT6D4413 DVS Bus ESBC Terminator

PEC	CPC	Length	Description
NT6D4413	A0364037	9 in.	(2) 2x31HDR-2x31Socket, Ribbon

NT6D4414 DVS Bus Node 1 to 2 Cable

PEC	CPC	Length	Description
NT6D4414	A0364038	60 in.	2x30-2x30Socket, Ribbon

NT6D4415 DVS Bus HABC Terminator

PEC	CPC	Length	Description
NT6D4415	A0364039	76 ft	2x30-2x30Socket, Ribbon

NT6D4416 DVS Bus, Node 2 to 3 Cable

PEC	CPC	Length	Description
NT6D4416	A0364040	6 ft	2x30-2x30Socket, Ribbon

NT6D54 QBL15 Field Wiring Kit (DC)

PEC	CPC	Length	Description
NT6D54AA	A0366358	—	Harness, Loose

NT6P0110 Four-Port Cable

PEC	CPC	Length	Description
NT6D10	A0393843	15 in.	M50Telco-(4)M25DB, Round

NT7D61Ex SDI I/O Cable

PEC	CPC	Length	Description
NT7D61EB	A0409376	2 ft	M25DB-F9DB Round
NT7D61ED	A0409377	6 ft	M25DB-F9DB Round
NT7D61EF	A0409378	10 ft	M25DB-F9DB Round
NT7D61EL	A0409379	25 ft	M25DB-F9DB Round
NT7D61ET	A0409380	30 ft	M25DB-F9DB Round
NT7D61EV	A0409381	45 ft	M25DB-F9DB Round

NT7D89 RS-232 to I/O Panel Cable

PEC	CPC	Length	Description
NT7D89AA	A0387795	2 ft	F60IDT-(2)F25DB, Round
NT7D89BA	A0402055	13 in.	F60IDT-(2)F25DB, Round

NT7D90 Ethernet to I/O Panel Cable

PEC	CPC	Length	Description
NT7D90AA	A0387796	2 ft	60IDT-F15DB, Round
NT7D90BA	A0402054	12 in.	60IDT-F15DB, Round

NT7D94 VME Transceiver Cable

PEC	CPC	Length	Description
NT7D94AA	A0387831		

NT7D95 VME Transition Cable

PEC	CPC	Length	Description
NT7D95AA	A0387839	10 ft	M25DB-F25DB, Ribbon

NT8D46AA System Monitor Stack Cable

PEC	CPC	Length	Description
NT8D46AA	A0356972	32 in.	F40-F40Socket, Ribbon

NT8D46AB System Monitor Jumper Cable

PEC	CPC	Length	Description
NT8D46AB	A0356973	11.25 in.	F50Telco-M40HDR, Ribbon

NT8D46AD System Monitor Quad Serial Data Interface Cable

PEC	CPC	Length	Description
NT8D46AD	A0357803	34/60 in.	F40Socket-F40Socket/25DB, Ribbon

NT8D46AF System Monitor Remote Serial Data Interface Cable

PEC	CPC	Length	Description
NT8D46AF	A0356979	33 ft	F25DB-F25DB, Round

NT8D46AG System Monitor to Extended Serial Data Interface Cable

PEC	CPC	Length	Description
NT8D46AG	A0356976	34 in.	F40-F40/10Socket, Ribbon

NT8D46AJ UPS Alarm Cable (AC)

PEC	CPC	Length	Description
NT8D46AJ	A0356978	45 ft	F9-M25DB, Round

NT8D46AK UPS Alarm Cable (AC)

PEC	CPC	Length	Description
NT8D46AK	A0356980	45 ft	F9-M25DB, Round

NT8D46AL System Monitor Serial Link Cable

PEC	CPC	Length	Description
NT8D46AL	A0359528	7 ft	RJ11-RJ11

NT8D46AN XDF to PFT Cable

PEC	CPC	Length	Description
NT8D46AN	A0356981	7 ft	F50Telco-Loose, Round

NT8D46AP System Monitor Serial Link Cable

PEC	CPC	Length	Description
NT8D46AP	A0356529	25 ft	RJ11-RJ11

NT8D46AQ UPS Alarm Cable (AC)

PEC	CPC	Length	Description
NT8D46AQ	A0362567	45 ft	F9DB-M9DB, Round

NT8D46AS System Monitor Inter-CPU Cable

PEC	CPC	Length	Description
NT8D46AS	A0365088	9 ft	F40Socket-F40/F40Socket, Ribbon

NT8D46AT System Monitor/QBL15 Cable (DC)

PEC	CPC	Length	Description
NT8D46AT	A0366098	32 ft	F9DB-Lugs, Round

NT8D46AU UPS Alarm Cable (AC)

PEC	CPC	Length	Description
NT8D46AU	A0366276	45 ft	F9DB-M5IDT, Round

NT8D46AV System Monitor/QCA13 Cable (DC)

PEC	CPC	Length	Description
NT8D46AV	A0366277	32 ft	F9DB-Lugs, Round

NT8D46AW System Monitor/QBL12 Cable (DC)

PEC	CPC	Length	Description
NT8D46AW	A0366310	32 ft	F9DB-Lugs, Round

NT8D46AX System Monitor CE/PE ST Upgrade Cable

PEC	CPC	Length	Description
NT8D46AX	A0371062	45 ft	F9DB-M25DB, Round

NT8D46AY System Monitor XPE ST Upgrade Cable

PEC	CPC	Length	Description
NT8D46AY	A0371063	45 ft	F9DB-M25DB, Round

NT8D46BA ST Upgrade QCA136 Internal Cable

PEC	CPC	Length	Description
NT8D46BA	A0373191	—	Harness, Loose, Socket

NT8D46BB ST Upgrade QCA136 Internal Cable with Expansion

PEC	CPC	Length	Description
NT8D46BB	A0373192	—	Harness, Loose, Socket

NT8D46BC ST Upgrade QCA137 External Cable

PEC	CPC	Length	Description
NT8D46BC	A0373193	6 ft	M25DB-M25DB, Round

NT8D46BD ST Upgrade QCA136 External Adapter Cable

PEC	CPC	Length	Description
NT8D46BD	A0373194	12 in.	M25DB-F9/F25DB, Round

NT8D46BE ST Upgrade QCA136 External Cable

PEC	CPC	Length	Description
NT8D46BE	A0373195	10 ft	M9DB-F9DB, Round

NT8D46BF ST/RT Upgrade System Monitor External Adapter Cable

PEC	CPC	Length	Description
NT8D46BF	A0373196	12 in.	F9DB-M9/M9DB, Round

NT8D46BG RT Upgrade QCA147 Internal Cable

PEC	CPC	Length	Description
NT8D46BG	A0373197	—	Harness, Loose, Header

NT8D46BH System Monitor to MDF Cable

PEC	CPC	Length	Description
NT8D46BH	A0372848	45 ft	F9DB-Loose

NT8D46BJ Upgrade QCA147 Internal Cable with Expansion

PEC	CPC	Length	Description
NT8D46BJ	A0373199	—	Harness, Loose, Socket

NT8D46BK RT Upgrade QCA137 External Cable with Expansion

PEC	CPC	Length	Description
NT8D46BK	A0373200	12 in.	M25DB-F25/F9DB, Round

NT8D46BL RT Upgrade QCA147 w/Expnsn Ext. Adapter Cable

PEC	CPC	Length	Description
NT8D46BL	A0373701	12 in.	M25DB-F25/F9DB, Round

NT8D46BM ST Upgrade QCA136 w/Expnsn Ext. Adapter Cable

PEC	CPC	Length	Description
NT8D46BM	A0373702	12 in.	M25DB-F25/F9DB, Round

NT8D46CD System Monitor to AEM Cable

PEC	CPC	Length	Description
NT8D46CD	A0401119		F50Telco-F40 Socket, Ribbon

NT8D46CH RT Upgrade QCA147 External Cable

PEC	CPC	Length	Description
NT8D46CH	A0373198	12 ft	M25DB-F9DB, Round

NT8D46DH/EH System Monitor to MDF Cable

PEC	CPC	Length	Description
NT8D46DH	A0388610	150 ft	F9DB-Loose, Round
NT8D46EH	A0379247	100 ft	F9DB-Loose, Round

NT8D46FH System Monitor to SL-100 Cable

PEC	CPC	Length	Description
NT8D46FH	A0390418	Variable	F9DB-Loose, Round

NT8D73 Network I/O to Network I/O Intercabinet Cable

PEC	CPC	Length	Description
NT8D73AD	A0359306	6 ft	M36Telco-M36Telco, Round
NT8D73AF	A0359532	12 ft	M36Telco-M36Telco, Round
NT8D73AL	A0359533	20 ft	M36Telco-M36Telco, Round
NT8D73AS	A0359534	30 ft	M36Telco-M36Telco, Round

NT8D74 Clock Controller to Junctor Cable

PEC	CPC	Length	Description
NT8D74CC	A0406496	4 ft	F50Telco-F50Telco, Round
NT8D74BD	A0406497	6 ft	F50Telco-F50Telco, Round
NT8D74BE	A0406498	8 ft	F50Telco-F50Telco, Round
NT8D74BF	A0406499	10 ft	F50Telco-F50Telco, Round
NT8D74BJ	A0406500	16 ft	F50Telco-F50Telco, Round

NT8D75 Clock Controller to Clock Controller Cable

PEC	CPC	Length	Description
NT8D75BC	A0406501	4 ft	F50Telco-F50Telco, Round
NT8D75BD	A0406502	6 ft	F50Telco-F50Telco, Round

NT8D76 InterGroup Switch to Junctor Cable

PEC	CPC	Length	Description
NT8D76BC	A0406503	4 ft	M50Telco-M50Telco, Round
NT8D76BD	A0406504	5 ft	M50Telco-M50Telco, Round
NT8D76BE	A0406505	6 ft	M50Telco-M50Telco, Round
NT8D76BF	A0406506	8 ft	M50Telco-M50Telco, Round
NT8D76BG	A0406507	10 ft	M50Telco-M50Telco, Round
NT8D76BJ	A0406508	12 ft	M50Telco-M50Telco, Round
NT8D76BL	A0406509	14 ft	M50Telco-M50Telco, Round
NT8D76BP	A0406510	16 ft	M50Telco-M50Telco, Round
NT8D76BR	A0406510	25 ft	M50Telco-M50Telco, Round
NT8D76BS	A0406510	50 ft	M50Telco-M50Telco, Round

NT8D77 Floppy Disk Interface to Floppy Drive Unit Cable

PEC	CPC	Length	Description
NT8D77BA	A0406511	3 ft	F50Telco-M50Telco, Round
NT8D77BB	A0406512	2 ft	F50Telco-M50Telco, Round
NT8D77BC	A0406513	4 ft	F50Telco-M50Telco, Round
NT8D77BD	A0406514	6 ft	F50Telco-M50Telco, Round

NT8D78 CPU Cable

PEC	CPC	Length	Description
NT8D78AA	A0356982	2 in.	2x17Socket-2x17Socket, Ribbon

NT8D79 DTI to Clock Controller Cable

PEC	CPC	Length	Description
NT8D79AB	A0360015	2 ft	M9DB-M9DB, Round
NT8D79AC	A0360016	4 ft	M9DB-M9DB, Round
NT8D79AD	A0360017	6 ft	M9DB-M9DB, Round
NT8D79AE	A0360018	8 ft	M9DB-M9DB, Round
NT8D79AF	A0360019	10 ft	M9DB-M9DB, Round

NT8D80 CPU Interface Cable

PEC	CPC	Length	Description
NT8D80BB	A0406520	2 ft	M50Telco-M50Telco, Round
NT8D80BC	A0406521	4 ft	M50Telco-M50Telco, Round
NT8D80BD	A0406522	6 ft	M50Telco-M50Telco, Round
NT8D80BE	A0406523	8 ft	M50Telco-M50Telco, Round
NT8D80BF	A0406524	10 ft	M50Telco-M50Telco, Round
NT8D80BG	A0406525	12 ft	M50Telco-M50Telco, Round
NT8D80BJ	A0406526	16 ft	M50Telco-M50Telco, Round
NT8D80BL	A0406527	20 ft	M50Telco-M50Telco, Round
NT8D80BP	A0406528	25 ft	M50Telco-M50Telco, Round
NT8D80BZ	A0406529	5 ft	M50Telco-M50Telco, Round

NT8D81 B/P Tip and Ring to I/O Cable

PEC	CPC	Length	Description
NT8D81AA	A0359946	20 in.	M50Telco-(3)2x10Socket, Ribbon

NT8D82 SDI to I/O Cable

PEC	CPC	Length	Description
NT8D82AC	A0359307	4 ft	M25DB-F25DB, Round
NT8D82AD	A0362867	6 ft	M25DB-F25DB, Round

NT8D83 DTI to I/O Cable

PEC	CPC	Length	Description
NT8D83AC	A0358531	4 ft	M15DB-M15DB, Round
NT8D83AD	A0362868	6 ft	M15DB-M15DB, Round

NT8D84 XSDI to I/O Cable

PEC	CPC	Length	Description
NT8D84AA	A0357203	18 in.	2x5Socket-M9DB, Ribbon

NT8D85 Network to PE Cable

PEC	CPC	Length	Description
NT8D85BB	A0406533	2 ft	M36Telco-M36Telco, Round
NT8D85BC	A0406534	4 ft	M36Telco-M36Telco, Round
NT8D85BD	A0406535	6 ft	M36Telco-M36Telco, Round
NT8D85BE	A0406536	8 ft	M36Telco-M36Telco, Round
NT8D85BF	A0406537	10 ft	M36Telco-M36Telco, Round
NT8D85BJ	A0406538	16 ft	M36Telco-M36Telco, Round
NT8D85BL	A0406539	20 ft	M36Telco-M36Telco, Round
NT8D85BP	A0406540	25 ft	M36Telco-M36Telco, Round
NT8D85BV	A0406541	45 ft	M36Telco-M36Telco, Round
NT8D85BZ	A0406542	5 ft	M36Telco-M36Telco, Round

NT8D86 Network to I/O Cable

PEC	CPC	Length	Description
NT8D86AC	A0359311	5 ft	M36Telco-F36Telco, Round
NT8D86AD	A0362869	6 ft	M36Telco-F36Telco, Round

NT8D88 Superloop Network Card to I/O Cable

PEC	CPC	Length	Description
NT8D88AC	A0359308	5 ft	M24Telco-M24Telco, Round
NT8D88AD	A0362871	6 ft	M24Telco-M24Telco, Round

NT8D90 SDI Multiple Port Extension Cable

PEC	CPC	Length	Description
NT8D90AF	A0358948	10 ft	M25DB-F25DB, Round

NT8D91 Superloop Network to Peripheral Controller Cable

PEC	CPC	Length	Description
NT8D91AC	A0358526	4 ft	M24Telco-F24Socket, Round
NT8D91AD	A0358527	6 ft	M24Telco-F24Socket, Round
NT8D91AE	A0358528	8 ft	M24Telco-F24Socket, Round
NT8D91AF	A0358529	10 ft	M24Telco-F24Socket, Round
NT8D91AG	A0358530	12 ft	M24Telco-F24Socket, Round
NT8D91AJ	A0358918	16 ft	M24Telco-F24Socket, Round
NT8D91AP	A0358924	25 ft	M24Telco-F24Socket, Round
NT8D91AT	A0365604	35 ft	M24Telco-F24Socket, Round
NT8D91AV	A0358923	45 ft	M24Telco-F24Socket, Round

NT8D92 I/O to Peripheral Controller Cable

PEC	CPC	Length	Description
NT8D92AB	A0359309	20 in.	M24Telco-F24Socket, Round

NT8D93 XSDI I/O to DTE or DCE Cable

PEC	CPC	Length	Description
NT8D93AJ	A0357270	16 ft	M25DB-M9DB, Round
NT8D93AW	A0357271	48 ft	M25DB-M9DB, Round

NT8D95 SDI I/O Panel to DTE or DCE Cable

PEC	CPC	Length	Description
NT8D95AJ	A0358909	16 ft	M25DB-M9DB, Round
NT8D95AT	A0358910	34 ft	M25DB-M9DB, Round
NT8D95AW	A0358911	48 ft	M25DB-M9DB, Round

NT8D96 SDI Multiple Port Cable

PEC	CPC	Length	Description
NT8D96AB	A0358952	2 ft	M25DB-(3)F25DB, Round

NT8D98 Superloop Network I/O to Superloop Network I/O Intercabinet Network Cable

PEC	CPC	Length	Description
NT8D98AD	A0363633	6 ft	M24Telco-M24Telco, Round
NT8D98AF	A0363751	12 ft	M24Telco-M24Telco, Round
NT8D98AL	A0363752	20 ft	M24Telco-M24Telco, Round
NT8D98AS	A0363753	30 ft	M24Telco-M24Telco, Round
NT8D98AT	A0365600	38 ft	M24Telco-M24Telco, Round

NT8D99 CPU to Network Cable

PEC	CPC	Length	Description
NT8D99BB	A0616247	26 in	M36Telco-M36Telco, Round
NT8D99AC	A0357259	4 ft	M36Telco-M36Telco, Round
NT8D99BD	A616249	66 in	M36Telco-M36Telco, Round

NT9D89 CNI-3 to 3PE Cable

PEC	Length	Description
NT9D89CA	8 ft	Used when faceplate port “C” is configured
NT9D89DA	10 ft	Used when faceplate port “C” is configured
NT9D89EA	12 ft	Used when faceplate port “C” is configured
NT9D89FA	25 ft	Used when faceplate port “C” is configured
NT9D89GA	50 ft	Used when faceplate port “C” is configured

NT9J93 DTI Echo Canceler to I/O Cable

PEC	CPC	Length	Description
NT9J93AD	A0363202	6 ft	M15DB-F15DB, Round

NT9J94 RPE to I/O Cable

PEC	CPC	Length	Description
NT9J94AB	A0363204	2 ft	F50Telco-F50Telco, Round

NT9J96 Network to I/O Intracabinet Network Cable

PEC	CPC	Length	Description
NT9J96AC	A0359316	40 in.	M36Telco-F36Telco, Round
NT9J96AD	A0359540	70 in.	M36Telco-F36Telco, Round
NT9J96AE	A0359541	85 in.	M36Telco-F36Telco, Round
NT9J96AG	A0359542	12 ft	M36Telco-F36Telco, Round
NT9J96AH	A0359543	14 ft	M36Telco-F36Telco, Round
NT9J96AJ	A0359544	16 ft	M36Telco-F36Telco, Round

NT9J97 Superloop Network to I/O Intracabinet Network Cable

PEC	CPC	Length	Description
NT9J97AC	A0359317	40 in.	M24Telco-F24Telco, Round
NT9J97AD	A0359545	70 in.	M24Telco-F24Telco, Round
NT9J97AE	A0359546	85 in.	M24Telco-F24Telco, Round
NT9J97AG	A0359547	12 ft	M24Telco-F24Telco, Round
NT9J97AH	A0359548	14 ft	M24Telco-F24Telco, Round
NT9J97AJ	A0359549	16 ft	M24Telco-F24Telco, Round

NT9J98 Network to ST I/O Intracabinet Network Cable

PEC	CPC	Length	Description
NT9J98AC	A0359531	40 in.	M36Telco-F36Telco, Round
NT9J98AD	A0359550	70 in.	M36Telco-F36Telco, Round
NT9J98AE	A0359551	85 in.	M36Telco-F36Telco, Round

NT9J99 Superloop Network to ST I/O Intracabinet Network Cable

PEC	CPC	Length	Description
NT9J99AC	A0359315	40 in.	M24Telco-F24Telco, Round
NT9J99AD	A0359552	70 in.	M24Telco-F24Telco, Round
NT9J99AE	A0359553	85 in.	M24Telco-F24Telco, Round

NTAK0410 Battery Cable

PEC	CPC	Length	Description
NTAK0410	A0373953	6 ft	1x5Socket-1x2Socket, Round

NTBK04 1.5MB DTI/PRI T1 Cable

PEC	CPC	Length	Description
NTBK04AA	A0394216	20 ft	F50Telco-F15DB, Round

NTBK04 1.5MB Carrier/Clock Cable

PEC	CPC	Length	Description
NTBK04AB	A0394641	20 ft	F50Telco-M15DB, Round

NTBK04 1.5MB DTI/PRI Carrier Cable

PEC	CPC	Length	Description
NTBK04BA	A0394953	6 ft	M25DB-(2)M15DB, Round

NTBK04 1.5MB DTI/PRI Carrier Cable

PEC	CPC	Length	Description
NTBK04CA	A0394217	20 ft	F50Telco-M15DB, Round

NTBK05 SDT12 120-OHM E1 Cable

PEC	CPC	Length	Description
NTBK05AA	A0394217	20 ft	F50Telco-M9DB, Round

NTBK05 2MB DTI/PRI Coax Carrier Cable

PEC	CPC	Length	Description
NTBK05CA	A0397000	20 ft	F50Telco-(2)BNC, Round

NTND11 CMB to CMB Cable

PEC	CPC	Length	Description
NTND11AA	A0389598	6 ft	4x15HDR-4x15HDR, Round

NTND13 SCSI Cable

PEC	CPC	Length	Description
NTND13AA	A0389600	1 ft	4x15Socket-4x15Socket, Round
NTND13AB	A0396616	3.5 ft	4x15Socket-4x15Socket, Round
NTND13AC	A0396617	6 ft	4x15Socket-4x15Socket, Round

NTND14 CNI to 3PE Cable

PEC	CPC	Length	Description
NTND14AA	A0389601	5 ft	4x15Socket-M50Telco, Round
NTND14AB	A0389602	10 ft	4x15Socket-M50Telco, Round
NTND14AC	A0389603	12 ft	4x15Socket-M50Telco, Round
NTND14AD	A0389604	16 ft	4x15Socket-M50Telco, Round
NTND14AE	A0389605	25 ft	4x15Socket-M50Telco, Round
NTND14AF	A0389606	30 ft	4x15Socket-M50Telco, Round
NTND14AG	A0389755	35 ft	4x15Socket-M50Telco, Round
NTND14AX	A0396422	50 ft	4x15Socket-M50Telco, Round
NTND14AW	A0396936	2 ft	4x15Socket-M50Telco, Round

NTND26 MDSL to DCHI Cable

PEC	CPC	Length	Description
NTND26AA	A0393414	6 ft	SCSII-15DB, Round
NTND26AB	A0393415	18 ft	SCSII-15DB, Round
NTND26AC	A0393416	35 ft	SCSII-15DB, Round
NTND26AD	A0393417	50 ft	SCSII-15DB, Round

NTND27 MSDL to I/O Panel Cable

PEC	CPC	Length	Description
NTND27AA	A0393418	4 ft	SCSII-25DB, Round

NTND27 MSDL SDI/AM2 Cable

PEC	CPC	Length	Description
NTND27AB	A0393419	6 ft	SCSII-25DB, Round

NTND28 Network Expansion Intercabinet Cable

PEC	CPC	Length	Description
NTND28BA	A0399441	13 ft	F50-F50Telco, Round
NTND28BB	A0399490	16 ft	F50-F50Telco, Round
NTND28BA	A0399491	22 ft	F50-F50Telco, Round

NTND29 Network Expansion CPU Interface Cable

PEC	CPC	Length	Description
NTND29AA	A0393903	6 ft	M50Telco-M50Telco, Round

NTND30 Network Expansion Junctor to I/O Housing Cable

PEC	CPC	Length	Description
NTND30AA	A0393904	6 ft	M50Telco-M50Telco, Round

NTND37 Dual SDI Cable

PEC	CPC	Length	Description
NTND37AA	A0394677	8 ft	M25DB-(2)F25DB, Round

NTND71 BRA Clock Reference to Clock Controller Cable

PEC	CPC	Length	Description
NTND71AA	A0398302	6.5 ft	M9DB-M9DB, Round
NTND71AB	A0398303	12 ft	M9DB-M9DB, Round
NTND71AC	A0398304	25 ft	M9DB-M9DB, Round
NTND71AD	A0398305	42 ft	M9DB-M9DB, Round

NTND72 Clock Reference to Clock Controller Cable

PEC	CPC	Length	Description
NTND72	A0398306	6.5 ft	F9DB-(2)M9DB, Round

NTND82 Printer to LIU Cable

PEC	CPC	Length	Description
NTND82AA	A0398761	10 ft	M25DB-M25DB, Round
NTND82AB	A0398762	25 ft	M25DB-M25DB, Round

NTND91 CSL Cable

PEC	CPC	Length	Description
NTND91AA	A0399143	10 ft	M25DB-M25DB, Round
NTND91AB	A0399144	25 ft	M25DB-M25DB, Round

NTND91 Extension-25DB Cable

PEC	CPC	Length	Description
NTND91BA	A0401606	10 ft	M25DB-F25DB, Round
NTND91BB	A0401607	25 ft	M25DB-F25DB, Round

NTND94 CNI to I/O Panel Cable

PEC	CPC	Length	Description
NTND94AA	A0399239	6 ft	4x15Socket-M50Telco, Round

NTND94 Cable

PEC	CPC	Length	Description
NTND94BA	A0402023	17.5 in.	4x15Socket-M50Telco, Round
NTND94CA	A0402056	13 in.	4x15Socket-M50Telco, Round

NTND95 EMI Box to 3PE Cable

PEC	CPC	Length	Description
NTND95AA	A0399240	8 ft	M50Telco-M50Telco, Round

NTRC46 Clock to FIJI Cable

PEC	CPC	Length
NTRC46AA	A0757801	4 ft - 13.5 ft (see note)
NTRC46BA	A0757802	5.5 ft - 8 ft (see note)
NTRC46CA	A0757803	22 ft - 22 ft (see note)

Note: The “length” indicates the lengths of the two “Y” terminations.

NTRC47 FIJI to FIJI Sync Cable

PEC	CPC	Length
NTRC47AA	A0757471	5 ft

NTRC48 Fiber Ring Cable

PEC	CPC	Length	Description
NTRC48AA	A0757804	6 ft	fiber optic cable
NTRC48BA	A0757806	10 ft	fiber optic cable
NTRC48CA	A0757807	12 ft	fiber optic cable
NTRC48DA	A0757808	14 ft	fiber optic cable
NTRC48EA	A0757809	19 ft	fiber optic cable
NTRC48FA	A0757810	26 ft	fiber optic cable
NTRC48GA	A0757811	32 ft	fiber optic cable
NTRC48HA		50 ft	fiber optic cable

NTRC49 Clock to Clock Cable

PEC	Length
NTRC49AA	6 ft
NTRC49BA	20 ft

Appendix B: Cabling assignment tables

Appendix B contains the cabling assignment tables defined in previous sections of this document.

Content list

The following are the topics in this section:

- [NT8D37 IPE Module T&R Cable A \(Part 1 of 2\)](#) 86
- [NT8D37 IPE Module T&R Cable B \(Part 1 of 2\)](#) 88
- [NT8D37 IPE Module T&R Cable C \(Part 1 of 2\)](#) 90
- [NT8D37 IPE Module T&R Cable E \(Part 1 of 2\)](#) 92
- [NT8D37 IPE Module T&R Cable F \(Part 1 of 2\)](#) 94
- [NT8D37 IPE Module T&R Cable G \(Part 1 of 2\)](#) 96
- [NT8D37 IPE Module T&R Cable K \(Part 1 of 2\)](#) 98
- [NT8D37 IPE Module T&R Cable L \(Part 1 of 2\)](#) 100
- [NT8D37 IPE Module T&R Cable M \(Part 1 of 2\)](#) 102
- [NT8D37 IPE Module T&R Cable R \(Part 1 of 2\)](#) 104
- [NT8D37 IPE Module T&R Cable S \(Part 1 of 2\)](#) 106
- [NT8D37 IPE Module T&R Cable T \(Part 1 of 2\)](#) 108
- [NT8D37 IPE Module SLO loop cabling](#) 110
- [NT8D37 IPE Module SL1 loop cabling](#) 111
- [NT8D37 IPE Module SL2 loop cabling](#) 112
- [NT8D37 IPE Module SL3 loop cabling](#) 113

- [Cabling between two NT8D35 XNE Modules 114](#)
- [Network to junctor cabling 115](#)
- [NT7D19 Meridian Link Module cabling 116](#)

Table 4
NT8D37 IPE Module T&R Cable A (Part 1 of 2)

From				To		
Card Slot	B/P Conn	B/P Pin	Signal	I/O Cable	I/O Conn	Pin Num
0	1	12A	R0	A	1	1
0	1	12B	T0	A	1	26
0	1	13A	R1	A	1	2
0	1	13B	T1	A	1	27
0	1	14A	R2	A	1	3
0	1	14B	T2	A	1	28
0	1	15A	R3	A	1	4
0	1	15B	T3	A	1	29
0	1	16A	R4	A	1	5
0	1	16B	T4	A	1	30
0	1	17A	R5	A	1	6
0	1	17B	T5	A	1	31
0	1	18A	R6	A	1	7
0	1	18B	T6	A	1	32
0	1	19A	R7	A	1	8
0	1	19B	T7	A	1	33
0	2	62A	R8	A	2	9
0	2	62B	T8	A	2	34
0	2	63A	R9	A	2	10
0	2	63B	T9	A	2	35
0	2	64A	R10	A	2	11
0	2	64B	T10	A	2	36
0	2	65A	R11	A	2	12
0	2	65B	T11	A	2	37
0	2	66A	R12	A	2	13
0	2	66B	T12	A	2	38
0	2	67A	R13	A	2	14
0	2	67B	T13	A	2	39
0	2	68A	R14	A	2	15
0	2	68B	T14	A	2	40
0	2	69A	R15	A	2	16
0	2	69B	T15	A	2	41

* Reserved for future packs requiring 24 T&R.

Table 4
NT8D37 IPE Module T&R Cable A (Part 2 of 2)

From				To		
Card Slot	B/P Conn	B/P Pin	Signal	I/O Cable	I/O Conn	Pin Num
0	3	73A	*R16	A	3	17
0	3	73B	*T16	A	3	42
0	3	74A	*R17	A	3	18
0	3	74B	*T17	A	3	43
0	3	75A	*R18	A	3	19
0	3	75B	*T18	A	3	44
0	3	76A	*R19	A	3	20
0	3	76B	*T19	A	3	45
0	3	77A	*R20	A	3	21
0	3	77B	*T20	A	3	46
0	3	78A	*R21	A	3	22
0	3	78B	*T21	A	3	47
0	3	79A	*R22	A	3	23
0	3	79B	*T22	A	3	48
0	3	80A	*R23	A	3	24
0	3	80B	*T23	A	3	49

* Reserved for future packs requiring 24 T&R.

Table 5
NT8D37 IPE Module T&R Cable B (Part 1 of 2)

Card Slot	From			To		
	B/P Conn	B/P Pin	Signal	I/O Cable	I/O Conn	Pin Num
1	1	12A	R0	B	1	1
1	1	12B	T0	B	1	26
1	1	13A	R1	B	1	2
1	1	13B	T1	B	1	27
1	1	14A	R2	B	1	3
1	1	14B	T2	B	1	28
1	1	15A	R3	B	1	4
1	1	15B	T3	B	1	29
1	1	16A	R4	B	1	5
1	1	16B	T4	B	1	30
1	1	17A	R5	B	1	6
1	1	17B	T5	B	1	31
1	1	18A	R6	B	1	7
1	1	18B	T6	B	1	32
1	1	19A	R7	B	1	8
1	1	19B	T7	B	1	33
1	2	62A	R8	B	2	9
1	2	62B	T8	B	2	34
1	2	63A	R9	B	2	10
1	2	63B	T9	B	2	35
1	2	64A	R10	B	2	11
1	2	64B	T10	B	2	36
1	2	65A	R11	B	2	12
1	2	65B	T11	B	2	37
1	2	66A	R12	B	2	13
1	2	66B	T12	B	2	38
1	2	67A	R13	B	2	14
1	2	67B	T13	B	2	39
1	2	68A	R14	B	2	15
1	2	68B	T14	B	2	40
1	2	69A	R15	B	2	16
1	2	69B	T15	B	2	41

* Reserved for future packs requiring 24 T&R.

Table 5
NT8D37 IPE Module T&R Cable B (Part 2 of 2)

From				To		
Card Slot	B/P Conn	B/P Pin	Signal	I/O Cable	I/O Conn	Pin Num
2	1	12A	R0	B	3	17
2	1	12B	T0	B	3	42
2	1	13A	R1	B	3	18
2	1	13B	T1	B	3	43
2	1	14A	R2	B	3	19
2	1	14B	T2	B	3	44
2	1	15A	R3	B	3	20
2	1	15B	T3	B	3	45
2	1	16A	R4	B	3	21
2	1	16B	T4	B	3	46
2	1	17A	R5	B	3	22
2	1	17B	T5	B	3	47
2	1	18A	R6	B	3	23
2	1	18B	T6	B	3	48
2	1	19A	R7	B	3	24
2	1	19B	T7	B	3	49

* Reserved for future packs requiring 24 T&R.

Table 6
NT8D37 IPE Module T&R Cable C (Part 1 of 2)

From				To		
Card Slot	B/P Conn	B/P Pin	Signal	I/O Cable	I/O Conn	Pin Num
2	2	62A	R8	C	1	1
2	2	62B	T8	C	1	26
2	2	63A	R9	C	1	2
2	2	63B	T9	C	1	27
2	2	64A	R10	C	1	3
2	2	64B	T10	C	1	28
2	2	65A	R11	C	1	4
2	2	65B	T11	C	1	29
2	2	66A	R12	C	1	5
2	2	66B	T12	C	1	30
2	2	67A	R13	C	1	6
2	2	67B	T13	C	1	31
2	2	68A	R14	C	1	7
2	2	68B	T14	C	1	32
2	2	69A	R15	C	1	8
2	2	69B	T15	C	1	33
3	1	12A	R0	C	2	9
3	1	12B	T0	C	2	34
3	1	13A	R1	C	2	10
3	1	13B	T1	C	2	35
3	1	14A	R2	C	2	11
3	1	14B	T2	C	2	36
3	1	15A	R3	C	2	12
3	1	15B	T3	C	2	37
3	1	16A	R4	C	2	13
3	1	16B	T4	C	2	38
3	1	17A	R5	C	2	14
3	1	17B	T5	C	2	39
3	1	18A	R6	C	2	15
3	1	18B	T6	C	2	40
3	1	19A	R7	C	2	16
3	1	19B	T7	C	2	41

* Reserved for future packs requiring 24 T&R.

Table 6
NT8D37 IPE Module T&R Cable C (Part 2 of 2)

From				To		
Card Slot	B/P Conn	B/P Pin	Signal	I/O Cable	I/O Conn	Pin Num
3	2	62A	R8	C	3	17
3	2	62B	T8	C	3	42
3	2	63A	R9	C	3	18
3	2	63B	T9	C	3	43
3	2	64A	R10	C	3	19
3	2	64B	T10	C	3	44
3	2	65A	R11	C	3	20
3	2	65B	T11	C	3	45
3	2	66A	R12	C	3	21
3	2	66B	T12	C	3	46
3	2	67A	R13	C	3	22
3	2	67B	T13	C	3	47
3	2	68A	R14	C	3	23
3	2	68B	T14	C	3	48
3	2	69A	R15	C	3	24
3	2	69B	T15	C	3	49

* Reserved for future packs requiring 24 T&R.

Table 7
NT8D37 IPE Module T&R Cable E (Part 1 of 2)

Card Slot	From			To		
	B/P Conn	B/P Pin	Signal	I/O Cable	I/O Conn	Pin Num
4	1	12A	R0	E	1	1
4	1	12B	T0	E	1	26
4	1	13A	R1	E	1	2
4	1	13B	T1	E	1	27
4	1	14A	R2	E	1	3
4	1	14B	T2	E	1	28
4	1	15A	R3	E	1	4
4	1	15B	T3	E	1	29
4	1	16A	R4	E	1	5
4	1	16B	T4	E	1	30
4	1	17A	R5	E	1	6
4	1	17B	T5	E	1	31
4	1	18A	R6	E	1	7
4	1	18B	T6	E	1	32
4	1	19A	R7	E	1	8
4	1	19B	T7	E	1	33
4	2	62A	R8	E	2	9
4	2	62B	T8	E	2	34
4	2	63A	R9	E	2	10
4	2	63B	T9	E	2	35
4	2	64A	R10	E	2	11
4	2	64B	T10	E	2	36
4	2	65A	R11	E	2	12
4	2	65B	T11	E	2	37
4	2	66A	R12	E	2	13
4	2	66B	T12	E	2	38
4	2	67A	R13	E	2	14
4	2	67B	T13	E	2	39
4	2	68A	R14	E	2	15
4	2	68B	T14	E	2	40
4	2	69A	R15	E	2	16
4	2	69B	T15	E	2	41

* Reserved for future packs requiring 24 T&R.

Table 7
NT8D37 IPE Module T&R Cable E (Part 2 of 2)

From				To		
Card Slot	B/P Conn	B/P Pin	Signal	I/O Cable	I/O Conn	Pin Num
4	3	73A	*R16	E	3	17
4	3	73B	*T16	E	3	42
4	3	74A	*R17	E	3	18
4	3	74B	*T17	E	3	43
4	3	75A	*R18	E	3	19
4	3	75B	*T18	E	3	44
4	3	76A	*R19	E	3	20
4	3	76B	*T19	E	3	45
4	3	77A	*R20	E	3	21
4	3	77B	*T20	E	3	46
4	3	78A	*R21	E	3	22
4	3	78B	*T21	E	3	47
4	3	79A	*R22	E	3	23
4	3	79B	*T22	E	3	48
4	3	80A	*R23	E	3	24
4	3	80B	*T23	E	3	49

* Reserved for future packs requiring 24 T&R.

Table 8
NT8D37 IPE Module T&R Cable F (Part 1 of 2)

Card Slot	From			To		
	B/P Conn	B/P Pin	Signal	I/O Cable	I/O Conn	Pin Num
5	1	12A	R0	F	1	1
5	1	12B	T0	F	1	26
5	1	13A	R1	F	1	2
5	1	13B	T1	F	1	27
5	1	14A	R2	F	1	3
5	1	14B	T2	F	1	28
5	1	15A	R3	F	1	4
5	1	15B	T3	F	1	29
5	1	16A	R4	F	1	5
5	1	16B	T4	F	1	30
5	1	17A	R5	F	1	6
5	1	17B	T5	F	1	31
5	1	18A	R6	F	1	7
5	1	18B	T6	F	1	32
5	1	19A	R7	F	1	8
5	1	19B	T7	F	1	33
5	2	62A	R8	F	2	9
5	2	62B	T8	F	2	34
5	2	63A	R9	F	2	10
5	2	63B	T9	F	2	35
5	2	64A	R10	F	2	11
5	2	64B	T10	F	2	36
5	2	65A	R11	F	2	12
5	2	65B	T11	F	2	37
5	2	66A	R12	F	2	13
5	2	66B	T12	F	2	38
5	2	67A	R13	F	2	14
5	2	67B	T13	F	2	39
5	2	68A	R14	F	2	15
5	2	68B	T14	F	2	40
5	2	69A	R15	F	2	16
5	2	69B	T15	F	2	41

* Reserved for future packs requiring 24 T&R.

Table 8
NT8D37 IPE Module T&R Cable F (Part 2 of 2)

From				To		
Card Slot	B/P Conn	B/P Pin	Signal	I/O Cable	I/O Conn	Pin Num
6	1	12A	R0	F	3	17
6	1	12B	T0	F	3	42
6	1	13A	R1	F	3	18
6	1	13B	T1	F	3	43
6	1	14A	R2	F	3	19
6	1	14B	T2	F	3	44
6	1	15A	R3	F	3	20
6	1	15B	T3	F	3	45
6	1	16A	R4	F	3	21
6	1	16B	T4	F	3	46
6	1	17A	R5	F	3	22
6	1	17B	T5	F	3	47
6	1	18A	R6	F	3	23
6	1	18B	T6	F	3	48
6	1	19A	R7	F	3	24
6	1	19B	T7	F	3	49

* Reserved for future packs requiring 24 T&R.

Table 9
NT8D37 IPE Module T&R Cable G (Part 1 of 2)

From				To		
Card Slot	B/P Conn	B/P Pin	Signal	I/O Cable	I/O Conn	Pin Num
6	2	62A	R8	G	1	1
6	2	62B	T8	G	1	26
6	2	63A	R9	G	1	2
6	2	63B	T9	G	1	27
6	2	64A	R10	G	1	3
6	2	64B	T10	G	1	28
6	2	65A	R11	G	1	4
6	2	65B	T11	G	1	29
6	2	66A	R12	G	1	5
6	2	66B	T12	G	1	30
6	2	67A	R13	G	1	6
6	2	67B	T13	G	1	31
6	2	68A	R14	G	1	7
6	2	68B	T14	G	1	32
6	2	69A	R15	G	1	8
6	2	69B	T15	G	1	33
7	1	12A	R0	G	2	9
7	1	12B	T0	G	2	34
7	1	13A	R1	G	2	10
7	1	13B	T1	G	2	35
7	1	14A	R2	G	2	11
7	1	14B	T2	G	2	36
7	1	15A	R3	G	2	12
7	1	15B	T3	G	2	37
7	1	16A	R4	G	2	13
7	1	16B	T4	G	2	38
7	1	17A	R5	G	2	14
7	1	17B	T5	G	2	39
7	1	18A	R6	G	2	15
7	1	18B	T6	G	2	40
7	1	19A	R7	G	2	16
7	1	19B	T7	G	2	41

Table 9
NT8D37 IPE Module T&R Cable G (Part 2 of 2)

From				To		
Card Slot	B/P Conn	B/P Pin	Signal	I/O Cable	I/O Conn	Pin Num
7	2	62A	R8	G	3	17
7	2	62B	T8	G	3	42
7	2	63A	R9	G	3	18
7	2	63B	T9	G	3	43
7	2	64A	R10	G	3	19
7	2	64B	T10	G	3	44
7	2	65A	R11	G	3	20
7	2	65B	T11	G	3	45
7	2	66A	R12	G	3	21
7	2	66B	T12	G	3	46
7	2	67A	R13	G	3	22
7	2	67B	T13	G	3	47
7	2	68A	R14	G	3	23
7	2	68B	T14	G	3	48
7	2	69A	R15	G	3	24
7	2	69B	T15	G	3	49

Table 10
NT8D37 IPE Module T&R Cable K (Part 1 of 2)

From				To		
Card Slot	B/P Conn	B/P Pin	Signal	I/O Cable	I/O Conn	Pin Num
8	1	12A	R0	K	1	1
8	1	12B	T0	K	1	26
8	1	13A	R1	K	1	2
8	1	13B	T1	K	1	27
8	1	14A	R2	K	1	3
8	1	14B	T2	K	1	28
8	1	15A	R3	K	1	4
8	1	15B	T3	K	1	29
8	1	16A	R4	K	1	5
8	1	16B	T4	K	1	30
8	1	17A	R5	K	1	6
8	1	17B	T5	K	1	31
8	1	18A	R6	K	1	7
8	1	18B	T6	K	1	32
8	1	19A	R7	K	1	8
8	1	19B	T7	K	1	33
8	2	62A	R8	K	2	9
8	2	62B	T8	K	2	34
8	2	63A	R9	K	2	10
8	2	63B	T9	K	2	35
8	2	64A	R10	K	2	11
8	2	64B	T10	K	2	36
8	2	65A	R11	K	2	12
8	2	65B	T11	K	2	37
8	2	66A	R12	K	2	13
8	2	66B	T12	K	2	38
8	2	67A	R13	K	2	14
8	2	67B	T13	K	2	39
8	2	68A	R14	K	2	15
8	2	68B	T14	K	2	40
8	2	69A	R15	K	2	16
8	2	69B	T15	K	2	41

* Reserved for future packs requiring 24 T&R.

Table 10
NT8D37 IPE Module T&R Cable K (Part 2 of 2)

From				To		
Card Slot	B/P Conn	B/P Pin	Signal	I/O Cable	I/O Conn	Pin Num
8	3	73A	*R16	K	3	17
8	3	73B	*T16	K	3	42
8	3	74A	*R17	K	3	18
8	3	74B	*T17	K	3	43
8	3	75A	*R18	K	3	19
8	3	75B	*T18	K	3	44
8	3	76A	*R19	K	3	20
8	3	76B	*T19	K	3	45
8	3	77A	*R20	K	3	21
8	3	77B	*T20	K	3	46
8	3	78A	*R21	K	3	22
8	3	78B	*T21	K	3	47
8	3	79A	*R22	K	3	23
8	3	79B	*T22	K	3	48
8	3	80A	*R23	K	3	24
8	3	80B	*T23	K	3	49

* Reserved for future packs requiring 24 T&R.

Table 11
NT8D37 IPE Module T&R Cable L (Part 1 of 2)

From				To		
Card Slot	B/P Conn	B/P Pin	Signal	I/O Cable	I/O Conn	Pin Num
9	1	12A	R0	L	1	1
9	1	12B	T0	L	1	26
9	1	13A	R1	L	1	2
9	1	13B	T1	L	1	27
9	1	14A	R2	L	1	3
9	1	14B	T2	L	1	28
9	1	15A	R3	L	1	4
9	1	15B	T3	L	1	29
9	1	16A	R4	L	1	5
9	1	16B	T4	L	1	30
9	1	17A	R5	L	1	6
9	1	17B	T5	L	1	31
9	1	18A	R6	L	1	7
9	1	18B	T6	L	1	32
9	1	19A	R7	L	1	8
9	1	19B	T7	L	1	33
9	2	62A	R8	L	2	9
9	2	62B	T8	L	2	34
9	2	63A	R9	L	2	10
9	2	63B	T9	L	2	35
9	2	64A	R10	L	2	11
9	2	64B	T10	L	2	36
9	2	65A	R11	L	2	12
9	2	65B	T11	L	2	37
9	2	66A	R12	L	2	13
9	2	66B	T12	L	2	38
9	2	67A	R13	L	2	14
9	2	67B	T13	L	2	39
9	2	68A	R14	L	2	15
9	2	68B	T14	L	2	40
9	2	69A	R15	L	2	16
9	2	69B	T15	L	2	41

Table 11
NT8D37 IPE Module T&R Cable L (Part 2 of 2)

From				To		
Card Slot	B/P Conn	B/P Pin	Signal	I/O Cable	I/O Conn	Pin Num
10	1	12A	R0	L	3	17
10	1	12B	T0	L	3	42
10	1	13A	R1	L	3	18
10	1	13B	T1	L	3	43
10	1	14A	R2	L	3	19
10	1	14B	T2	L	3	44
10	1	15A	R3	L	3	20
10	1	15B	T3	L	3	45
10	1	16A	R4	L	3	21
10	1	16B	T4	L	3	46
10	1	17A	R5	L	3	22
10	1	17B	T5	L	3	47
10	1	18A	R6	L	3	23
10	1	18B	T6	L	3	48
10	1	19A	R7	L	3	24
10	1	19B	T7	L	3	49

Table 12
NT8D37 IPE Module T&R Cable M (Part 1 of 2)

From				To		
Card Slot	B/P Conn	B/P Pin	Signal	I/O Cable	I/O Conn	Pin Num
10	2	62A	R8	M	1	1
10	2	62B	T8	M	1	26
10	2	63A	R9	M	1	2
10	2	63B	T9	M	1	27
10	2	64A	R10	M	1	3
10	2	64B	T10	M	1	28
10	2	65A	R11	M	1	4
10	2	65B	T11	M	1	29
10	2	66A	R12	M	1	5
10	2	66B	T12	M	1	30
10	2	67A	R13	M	1	6
10	2	67B	T13	M	1	31
10	2	68A	R14	M	1	7
10	2	68B	T14	M	1	32
10	2	69A	R15	M	1	8
10	2	69B	T15	M	1	33
11	1	12A	R0	M	2	9
11	1	12B	T0	M	2	34
11	1	13A	R1	M	2	10
11	1	13B	T1	M	2	35
11	1	14A	R2	M	2	11
11	1	14B	T2	M	2	36
11	1	15A	R3	M	2	12
11	1	15B	T3	M	2	37
11	1	16A	R4	M	2	13
11	1	16B	T4	M	2	38
11	1	17A	R5	M	2	14
11	1	17B	T5	M	2	39
11	1	18A	R6	M	2	15
11	1	18B	T6	M	2	40
11	1	19A	R7	M	2	16
11	1	19B	T7	M	2	41

Table 12
NT8D37 IPE Module T&R Cable M (Part 2 of 2)

From				To		
Card Slot	B/P Conn	B/P Pin	Signal	I/O Cable	I/O Conn	Pin Num
11	2	62A	R8	M	3	17
11	2	62B	T8	M	3	42
11	2	63A	R9	M	3	18
11	2	63B	T9	M	3	43
11	2	64A	R10	M	3	19
11	2	64B	T10	M	3	44
11	2	65A	R11	M	3	20
11	2	65B	T11	M	3	45
11	2	66A	R12	M	3	21
11	2	66B	T12	M	3	46
11	2	67A	R13	M	3	22
11	2	67B	T13	M	3	47
11	2	68A	R14	M	3	23
11	2	68B	T14	M	3	48
11	2	69A	R15	M	3	24
11	2	69B	T15	M	3	49

Table 13
NT8D37 IPE Module T&R Cable R (Part 1 of 2)

Card Slot	From			To		
	B/P Conn	B/P Pin	Signal	I/O Cable	I/O Conn	Pin Num
12	1	12A	R0	R	1	1
12	1	12B	T0	R	1	26
12	1	13A	R1	R	1	2
12	1	13B	T1	R	1	27
12	1	14A	R2	R	1	3
12	1	14B	T2	R	1	28
12	1	15A	R3	R	1	4
12	1	15B	T3	R	1	29
12	1	16A	R4	R	1	5
12	1	16B	T4	R	1	30
12	1	17A	R5	R	1	6
12	1	17B	T5	R	1	31
12	1	18A	R6	R	1	7
12	1	18B	T6	R	1	32
12	1	19A	R7	R	1	8
12	1	19B	T7	R	1	33
12	2	62A	R8	R	2	9
12	2	62B	T8	R	2	34
12	2	63A	R9	R	2	10
12	2	63B	T9	R	2	35
12	2	64A	R10	R	2	11
12	2	64B	T10	R	2	36
12	2	65A	R11	R	2	12
12	2	65B	T11	R	2	37
12	2	66A	R12	R	2	13
12	2	66B	T12	R	2	38
12	2	67A	R13	R	2	14
12	2	67B	T13	R	2	39
12	2	68A	R14	R	2	15
12	2	68B	T14	R	2	40
12	2	69A	R15	R	2	16
12	2	69B	T15	R	2	41

* Reserved for future packs requiring 24 T&R.

Table 13
NT8D37 IPE Module T&R Cable R (Part 2 of 2)

From				To		
Card Slot	B/P Conn	B/P Pin	Signal	I/O Cable	I/O Conn	Pin Num
12	3	73A	*R16	R	3	17
12	3	73B	*T16	R	3	42
12	3	74A	*R17	R	3	18
12	3	74B	*T17	R	3	43
12	3	75A	*R18	R	3	19
12	3	75B	*T18	R	3	44
12	3	76A	*R19	R	3	20
12	3	76B	*T19	R	3	45
12	3	77A	*R20	R	3	21
12	3	77B	*T20	R	3	46
12	3	78A	*R21	R	3	22
12	3	78B	*T21	R	3	47
12	3	79A	*R22	R	3	23
12	3	79B	*T22	R	3	48
12	3	80A	*R23	R	3	24
12	3	80B	*T23	R	3	49

* Reserved for future packs requiring 24 T&R.

Table 14
NT8D37 IPE Module T&R Cable S (Part 1 of 2)

From				To		
Card Slot	B/P Conn	B/P Pin	Signal	I/O Cable	I/O Conn	Pin Num
13	1	12A	R0	S	1	1
13	1	12B	T0	S	1	26
13	1	13A	R1	S	1	2
13	1	13B	T1	S	1	27
13	1	14A	R2	S	1	3
13	1	14B	T2	S	1	28
13	1	15A	R3	S	1	4
13	1	15B	T3	S	1	29
13	1	16A	R4	S	1	5
13	1	16B	T4	S	1	30
13	1	17A	R5	S	1	6
13	1	17B	T5	S	1	31
13	1	18A	R6	S	1	7
13	1	18B	T6	S	1	32
13	1	19A	R7	S	1	8
15	1	19B	T7	S	1	33
13	2	62A	R8	S	2	9
13	2	62B	T8	S	2	34
13	2	63A	R9	S	2	10
13	2	63B	T9	S	2	35
13	2	64A	R10	S	2	11
13	2	64B	T10	S	2	36
13	2	65A	R11	S	2	12
13	2	65B	T11	S	2	37
13	2	66A	R12	S	2	13
13	2	66B	T12	S	2	38
13	2	67A	R13	S	2	14
13	2	67B	T13	S	2	39
13	2	68A	R14	S	2	15
13	2	68B	T14	S	2	40
13	2	69A	R15	S	2	16
13	2	69B	T15	S	2	41

Table 14
NT8D37 IPE Module T&R Cable S (Part 2 of 2)

From				To		
Card Slot	B/P Conn	B/P Pin	Signal	I/O Cable	I/O Conn	Pin Num
14	1	12A	R0	S	3	17
14	1	12B	T0	S	3	42
14	1	13A	R1	S	3	18
14	1	13B	T1	S	3	43
14	1	14A	R2	S	3	19
14	1	14B	T2	S	3	44
14	1	15A	R3	S	3	20
14	1	15B	T3	S	3	45
14	1	16A	R4	S	3	21
14	1	16B	T4	S	3	46
14	1	17A	R5	S	3	22
14	1	17B	T5	S	3	47
14	1	18A	R6	S	3	23
14	1	18B	T6	S	3	48
14	1	19A	R7	S	3	24
14	1	19B	T7	S	3	49

Table 15
NT8D37 IPE Module T&R Cable T (Part 1 of 2)

From				To		
Card Slot	B/P Conn	B/P Pin	Signal	I/O Cable	I/O Conn	Pin Num
14	2	62A	R8	T	1	1
14	2	62B	T8	T	1	26
14	2	63A	R9	T	1	2
14	2	63B	T9	T	1	27
14	2	64A	R10	T	1	3
14	2	64B	T10	T	1	28
14	2	65A	R11	T	1	4
14	2	65B	T11	T	1	29
14	2	66A	R12	T	1	5
14	2	66B	T12	T	1	30
14	2	67A	R13	T	1	6
14	2	67B	T13	T	1	31
14	2	68A	R14	T	1	7
14	2	68B	T14	T	1	32
14	2	69A	R15	T	1	8
14	2	69B	T15	T	1	33
15	1	12A	R0	T	2	9
15	1	12B	T0	T	2	34
15	1	13A	R1	T	2	10
15	1	13B	T1	T	2	35
15	1	14A	R2	T	2	11
15	1	14B	T2	T	2	36
15	1	15A	R3	T	2	12
15	1	15B	T3	T	2	37
15	1	16A	R4	T	2	13
15	1	16B	T4	T	2	38
15	1	17A	R5	T	2	14
15	1	17B	T5	T	2	39
15	1	18A	R6	T	2	15
15	1	18B	T6	T	2	40
15	1	19A	R7	T	2	16
15	1	19B	T7	T	2	41

Table 15
NT8D37 IPE Module T&R Cable T (Part 2 of 2)

From				To		
Card Slot	B/P Conn	B/P Pin	Signal	I/O Cable	I/O Conn	Pin Num
15	2	62A	R8	T	3	17
15	2	62B	T8	T	3	42
15	2	63A	R9	T	3	18
15	2	63B	T9	T	3	43
15	2	64A	R10	T	3	19
15	2	64B	T10	T	3	44
15	2	65A	R11	T	3	20
15	2	65B	T11	T	3	45
15	2	66A	R12	T	3	21
15	2	66B	T12	T	3	46
15	2	67A	R13	T	3	22
15	2	67B	T13	T	3	47
15	2	68A	R14	T	3	23
15	2	68B	T14	T	3	48
15	2	69A	R15	T	3	24
15	2	69B	T15	T	3	49

Table 16
NT8D37 IPE Module SLO loop cabling

Card Slot	From			To	
	B/P Conn	B/P Pin	Signal	I/O Conn	Pin Num
Controller	SLO	2A	RXLA0	J2	1
Controller	SLO	2B	RXLA0Z	J2	13
Controller	SLO	3A	RXLA1	J2	2
Controller	SLO	3B	RXLA1Z	J2	14
Controller	SLO	4A	RXLA2	J2	3
Controller	SLO	4B	RXLA2Z	J2	15
Controller	SLO	5A	RXLA3	J2	4
Controller	SLO	5B	RXLA3Z	J2	16
Controller	SLO	6A	TXLA0	J2	5
Controller	SLO	6B	TXLA0Z	J2	17
Controller	SLO	7A	TXLA1	J2	6
Controller	SLO	7B	TXLA1Z	J2	18
Controller	SLO	8A	TXLA2	J2	7
Controller	SLO	8B	TXLA2Z	J2	19
Controller	SLO	9A	TXLA3	J2	8
Controller	SLO	9B	TXLA3Z	J2	20
Controller	SLO	10A	M10A	J2	9
Controller	SLO	10B	M10AZ	J2	21
Controller	SLO	11A	FRM8A	J2	10
Controller	SLO	11B	FRM8AZ	J2	22
Controller	SLO	12A	MWOA	J2	11
Controller	SLO	12B	MWOAZ	J2	23
Controller	SLO	13A	MWIA	J2	12
Controller	SLO	13B	MWIAZ	J2	24

Table 17
NT8D37 IPE Module SL1 loop cabling

Card Slot	From			To	
	B/P Conn	B/P Pin	Signal	I/O Conn	Pin Num
Controller	SL1	68A	RXLB0	J3	1
Controller	SL1	68B	RXLB0Z	J3	13
Controller	SL1	69A	RXLB1	J3	2
Controller	SL1	69B	RXLB1Z	J3	14
Controller	SL1	70A	RXLB2	J3	3
Controller	SL1	70B	RXLB2Z	J3	15
Controller	SL1	71A	RXLB3	J3	4
Controller	SL1	71B	RXLB3Z	J3	16
Controller	SL1	72A	TXLB0	J3	5
Controller	SL1	72B	TXLB0Z	J3	17
Controller	SL1	73A	TXLB1	J3	6
Controller	SL1	73B	TXLB1Z	J3	18
Controller	SL1	74A	TXLB2	J3	7
Controller	SL1	74B	TXLB2Z	J3	19
Controller	SL1	75A	TXLB3	J3	8
Controller	SL1	75B	TXLB3Z	J3	20
Controller	SL1	76A	M10B	J3	9
Controller	SL1	76B	M10BZ	J3	21
Controller	SL1	77A	FRM8B	J3	10
Controller	SL1	77B	FRM8BZ	J2	22
Controller	SL1	78A	MWOB	J2	11
Controller	SL1	78B	MWOBZ	J2	23
Controller	SL1	79A	MWIB	J2	12
Controller	SL1	79B	MWIBZ	J2	24

Table 18
NT8D37 IPE Module SL2 loop cabling

Card Slot	From			To	
	B/P Conn	B/P Pin	Signal	I/O Conn	Pin Num
Controller	SL2	2A	RXLC0	J4	1
Controller	SL2	2B	RXLC0Z	J4	13
Controller	SL2	3A	RXLC1	J4	2
Controller	SL2	3B	RXLC1Z	J4	14
Controller	SL2	4A	RXLC2	J4	3
Controller	SL2	4B	RXLC2Z	J4	15
Controller	SL2	5A	RXLC3	J4	4
Controller	SL2	5B	RXLC3Z	J4	16
Controller	SL2	6A	TXLC0	J4	5
Controller	SL2	6B	TXLC0Z	J4	17
Controller	SL2	7A	TXLC1	J4	6
Controller	SL2	7B	TXLC1Z	J4	18
Controller	SL2	8A	TXLC2	J4	7
Controller	SL2	8B	TXLC2Z	J4	19
Controller	SL2	9A	TXLC3	J4	8
Controller	SL2	9B	TXLC3Z	J4	20
Controller	SL2	10A	M10C	J4	9
Controller	SL2	10B	M10CZ	J4	21
Controller	SL2	11A	FRM8C	J4	10
Controller	SL2	11B	FRM8CZ	J4	22
Controller	SL2	12A	MWOC	J4	11
Controller	SL2	12B	MWOCZ	J4	23
Controller	SL2	13A	MWIC	J4	12
Controller	SL2	13B	MWICZ	J4	24

Table 19
NT8D37 IPE Module SL3 loop cabling

Card Slot	From			To	
	B/P Conn	B/P Pin	Signal	I/O Conn	Pin Num
Controller	SL3	68A	RXLD0	J5	1
Controller	SL3	68B	RXLD0Z	J5	13
Controller	SL3	69A	RXLD1	J5	2
Controller	SL3	69B	RXLD1Z	J5	14
Controller	SL3	70A	RXLD2	J5	3
Controller	SL3	70B	RXLD2Z	J5	15
Controller	SL3	71A	RXLD3	J5	4
Controller	SL3	71B	RXLD3Z	J5	16
Controller	SL3	72A	TXLD0	J5	5
Controller	SL3	72B	TXLD0Z	J5	17
Controller	SL3	73A	TXLD1	J5	6
Controller	SL3	73B	TXLD1Z	J5	18
Controller	SL3	74A	TXLD2	J5	7
Controller	SL3	74B	TXLD2Z	J5	19
Controller	SL3	75A	TXLD3	J5	8
Controller	SL3	75B	TXLD3Z	J5	20
Controller	SL3	76A	M10D	J5	9
Controller	SL3	76B	M10DZ	J5	21
Controller	SL3	77A	FRM8D	J5	10
Controller	SL3	77B	FRM8DZ	J5	22
Controller	SL3	78A	MW0D	J5	11
Controller	SL3	78B	MW0DZ	J5	23
Controller	SL3	79A	MWID	J5	12
Controller	SL3	79B	MWIDZ	J5	24

Table 20
Cabling between two NT8D35 XNE Modules

From			To	
B/P CONNECTOR	Module	Cable	B/P CONNECTOR	Module
A	NET	NT8D99AB	A	NET
B	NET	NT8D99AB	B	NET
C	NET	NT8D99AB	C	NET
D	NET	NT8D99AB	D	NET
E	NET	NT8D99AB	E	NET

Table 21
Network to junctor cabling

Card	Card Conn	From				To	
		Slot	Module	Grp	Cable	Card Conn	Module
QPC412		2	NET 0	0	NT8D76	J6	JUNCTOR
QPC412		3	NET 0	0	NT8D76	J1	JUNCTOR
QPC412		2	NET 1	0	NT8D76	J17	JUNCTOR
QPC412		3	NET 1	0	NT8D76	J22	JUNCTOR
QPC412		2	NET 0	1	NT8D76	J7	JUNCTOR
QPC412		3	NET 0	1	NT8D76	J2	JUNCTOR
QPC412		2	NET 1	1	NT8D76	J16	JUNCTOR
QPC412		3	NET 1	1	NT8D76	J21	JUNCTOR
QPC412		2	NET 0	2	NT8D76	J8	JUNCTOR
QPC412		3	NET 0	2	NT8D76	J3	JUNCTOR
QPC412		2	NET 1	2	NT8D76	J15	JUNCTOR
QPC412		3	NET 1	2	NT8D76	J20	JUNCTOR
QPC412		2	NET 0	3	NT8D76	J9	JUNCTOR
QPC412		3	NET 0	3	NT8D76	J4	JUNCTOR
QPC412		2	NET 1	3	NT8D76	J14	JUNCTOR
QPC412		3	NET 1	3	NT8D76	J19	JUNCTOR
QPC412		2	NET 0	4	NT8D76	J10	JUNCTOR
QPC412		3	NET 0	4	NT8D76	J5	JUNCTOR
QPC412		2	NET 1	4	NT8D76	J13	JUNCTOR
QPC412		3	NET 1	4	NT8D76	J18	JUNCTOR
QPC471	J1	14	CPU 0		NT8D74	J11	JUNCTOR
QPC471	J1	14	CPU 1		NT8D74	J12	JUNCTOR

Table 22
NT7D19 Meridian Link Module cabling

From Card	To Card Connector	Slot	Cable	I/O Conn Panel	Card	Card Conn
MVME712AM	J1		NT7D79AA	J7		
MVME712AM	J4		NT7D46AA	J8		
MVME712AM	J12		NT7D60AA	J9		
MVME712AM	J15		NT7D59AA	J1, J2, J3, J4, J5, J6		
MVME712AM	J11		NT7D76AA		P2 Adapter	J2
MVME705B	J1, J2, J3	1, 2	NT7D48AA	J1, J2, J3, J4, J5, J6		
MVME705B	P2	1, 2	NT7D57AA		MVME333-2	P2
NT7D62AA	P3		NT7D56AA		P2 Adapter	J3
NT7D62AA	J3		NT7D53AA		ST1126N	J1
NT7D62AA	J1		NT7D53AA		ST1126N	J1
NT7D1901	P1		NT7D52AA		NT7D1802	P1, P2

Appendix C: Cross-reference listing

Appendix C contains a cross-reference listing of cable vintage correlations and tables that reference the old cable apparatus codes to the new cable Product Engineering Codes (PEC)

Content list

The following are the topics in this section:

- [Meridian 1 cable vintage correlation 118](#)
- [Discontinued cables 119](#)
- [Old apparatus to new PEC code 120](#)
- [New PEC to old apparatus code 123](#)

Table 23
Meridian 1 cable vintage correlation (Part 1 of 2)

Old Cables	New Cables	Description
NT8D74AC	NT8D74BC	Clock Controller Cable 4 ft
NT8D74AD	NT8D74BD	Clock Controller Cable 6 ft
NT8D74AE	NT8D74BE	Clock Controller Cable 8 ft
NT8D74AF	NT8D74BF	Clock Controller Cable 10 ft
NT8D76AC	NT8D76BC	IGS to InterGroup Module Cable 4 ft
NT8D76AD	NT8D76BD	IGS to InterGroup Module Cable 6 ft
NT8D76AE	NT8D76BE	IGS to InterGroup Module Cable 8 ft
NT8D76AF	NT8D76BF	IGS to InterGroup Module Cable 10 ft
NT8D76AG	NT8D76BG	IGS to InterGroup Module Cable 12 ft
NT8D76AJ	NT8D76BJ	IGS to InterGroup Module Cable 16 ft
NT8D76AP	NT8D76BP	IGS to InterGroup Module Cable 20 ft
NT8D77AA	NT8D77BA	Female Telco Cable 3 ft
NT8D77AB	NT8D77BB	Female Telco Cable 2 ft
NT8D77AC	NT8D77BC	Female Telco Cable 4 ft
NT8D77AD	NT8D77BD	Female Telco Cable 6 ft
NT8D80AC	NT8D80BC	CPU/MDU Interface Cable 4 ft
NT8D80AD	NT8D80BD	CPU/MDU Interface Cable 6 ft
NT8D80AE	NT8D80BE	CPU/MDU Interface Cable 8 ft
NT8D80AF	NT8D80BF	CPU/MDU Interface Cable 10 ft
NT8D80AG	NT8D80BG	CPU/MDU Interface Cable 12 ft
NT8D80AJ	NT8D80BJ	CPU/MDU Interface Cable 16 ft

Table 23
Meridian 1 cable vintage correlation (Part 2 of 2)

Old Cables	New Cables	Description
NT8D80AL	NT8D80BL	CPU/MDU Interface Cable 20 ft
NT8D80AP	NT8D80BP	CPU/MDU Interface Cable 25 ft
NT8D80AZ	NT8D80BZ	CPU/MDU Interface Cable 5 ft
NT8D85AB	NT8D85BB	Network to PE Cable 2 ft
NT8D85AC	NT8D85BC	Network to PE Cable 4 ft
NT8D85AD	NT8D85BD	Network to PE Cable 6 ft
NT8D85AE	NT8D85BE	Network to PE Cable 8 ft
NT8D85AF	NT8D85BF	Network to PE Cable 10 ft
NT8D85AJ	NT8D85BJ	Network to PE Cable 16 ft
NT8D85AL	NT8D85BL	Network to PE Cable 20 ft
NT8D85AP	NT8D85BP	Network to PE Cable 25 ft
NT8D85AV	NT8D85BV	Network to PE Cable 35 ft
NT8D85AZ	NT8D85BZ	Network to PE Cable 5 ft
NT8D86AD	NT8D86BD	Network to PE Cable 6 ft

Table 24
Discontinued cables

Discontinued	Replacement	Description
NT8D75AC	NT8D77BC	Clock Controller to Clock Controller
NT8D75AD	NT8D77BD	Clock Controller to Clock Controller
NT8D75AL	NT8D76BP	InterGroup to Junctor Cable 20 ft
NT8D80AB	NT9J80BC	CPU Interface Cable 2 ft

Table 25 references the old cable apparatus code to the new PEC.

Table 25
Old apparatus to new PEC code (Part 1 of 3)

Old apparatus	New PEC	Description
NE-A18QA	NT8D99AB	Equivalent PEC
NE-A18QA	NT8D99AC	Equivalent PEC
NE-A18QA	NT8D99AD	Equivalent PEC
NE-A25A	NT9J94AB	Equivalent PEC
QCAD36	NT8D95AJ	Equivalent PEC
QCAD37	NT8D95AW	Equivalent PEC
QCAD110A		No Equivalent PEC
QCAD110B	NT8D74AF	Equivalent PEC
QCAD120	NT8D82AC	Equivalent PEC
QCAD122A	NT8D76AC	Equivalent PEC
QCAD122B	NT8D76AD	Equivalent PEC
QCAD122C	NT8D76AF	Equivalent PEC
QCAD122D		No Equivalent PEC
QCAD122E	NT8D76AL	Equivalent PEC
QCAD122F	NT8D76AP	Equivalent PEC
QCAD122G	NT8D76AE	Equivalent PEC
QCAD123A	NT8D80AB	Equivalent PEC
QCAD123B		No Equivalent PEC
QCAD123C	NT8D80AC	Equivalent PEC
QCAD123D	NT8D80AD	Equivalent PEC
QCAD123E	NT8D80AF	Equivalent PEC

Table 25
Old apparatus to new PEC code (Part 2 of 3)

Old apparatus	New PEC	Description
QCAD123G	NT8D80AL	Equivalent PEC
QCAD123H	NT8D80AP	Equivalent PEC
QCAD124A		No Equivalent PEC
QCAD124B	NT8D85AC	Equivalent PEC
QCAD124C	NT8D85AD	Equivalent PEC
QCAD124D	NT8D85AF	Equivalent PEC
QCAD124E		No Equivalent PEC
QCAD124F	NT8D85AL	Equivalent PEC
QCAD124G	NT8D85AP	Equivalent PEC
QCAD124H	NT8D85AT	Equivalent PEC
QCAD124J	NT8D85AV	Equivalent PEC
QCAD124K		No Equivalent PEC
QCAD124L	NT8D85AZ	Equivalent PEC
QCAD124M	NT8D85AE	Equivalent PEC
QCAD125		No Equivalent PEC
QCAD130	NT8D79AF	Equivalent PEC
QCAD133	NT8D97AX	Equivalent PEC
QCAD240	NT8D78AA	Equivalent PEC
QCAD311A1	NT9J98AC	Equivalent PEC
QCAD311A2	NT9J98AD	Equivalent PEC
QCAD311A3	NT9J98AE	Equivalent PEC

Table 25
Old apparatus to new PEC code (Part 3 of 3)

Old apparatus	New PEC	Description
QCAD311A4	NT9J96AC	Equivalent PEC
QCAD311A5	NT9J96AD	Equivalent PEC
QCAD311A6	NT9J96AE	Equivalent PEC
QCAD312A	NT8D73AD	Equivalent PEC
QCAD312B	NT8D73AF	Equivalent PEC
QCAD317	NT8D83AC	Equivalent PEC
QCAD317	NT8D83AD	Equivalent PEC
QCAD320A	NT8D77AA	Equivalent PEC
QCAD320B	NT8D77AD	Equivalent PEC
QCAD333	NT8D96AB	Equivalent PEC

Table 26 references the new PEC to the old cable apparatus code.

Table 26
New PEC to old apparatus code (Part 1 of 5)

New PEC	Old apparatus	Description
NT8D73AD	QCAD312A	Equivalent Apparatus Code
NT8D73AF	QCAD312B	Equivalent Apparatus Code
NT8D73AL		No Equivalent Apparatus Code
NT8D73AS		No Equivalent Apparatus Code
NT8D74AC		No Equivalent Apparatus Code
NT8D74AD		No Equivalent Apparatus Code
NT8D74AE		No Equivalent Apparatus Code
NT8D74AF	QCAD110B	Equivalent Apparatus Code
NT8D74AJ		No Equivalent Apparatus Code
NT8D75AC		No Equivalent Apparatus Code
NT8D75AD		No Equivalent Apparatus Code
NT8D76AC	QCAD122A	Equivalent Apparatus Code
NT8D76AD	QCAD122B	Equivalent Apparatus Code
NT8D76AE	QCAD122G	Equivalent Apparatus Code
NT8D76AF	QCAD122C	Equivalent Apparatus Code
NT8D76AG		No Equivalent Apparatus Code
NT8D76AJ		No Equivalent Apparatus Code
NT8D76AL	QCAD122E	Equivalent Apparatus Code
NT8D76AP	QCAD122F	Equivalent Apparatus Code
NT8D77AA	QCAD320A	Equivalent Apparatus Code
NT8D77AB		No Equivalent Apparatus Code

Table 26
New PEC to old apparatus code (Part 2 of 5)

New PEC	Old apparatus	Description
NT8D77AB		No Equivalent Apparatus Code
NT8D77AD	QCAD320B	Equivalent Apparatus Code
NT8D78AA	QCAD240	Equivalent Apparatus Code
NT8D79AB		No Equivalent Apparatus Code
NT8D79AC		No Equivalent Apparatus Code
NT8D79AD		No Equivalent Apparatus Code
NT8D79AE		No Equivalent Apparatus Code
NT8D79AF	QCAD130	Equivalent Apparatus Code
NT8D80AB	QCAD123A	Equivalent Apparatus Code
NT8D80AC	QCAD123C	Equivalent Apparatus Code
NT8D80AD	QCAD123D	Equivalent Apparatus Code
NT8D80AE		No Equivalent Apparatus Code
NT8D80AF	QCAD123E	Equivalent Apparatus Code
NT8D80AG		No Equivalent Apparatus Code
NT8D80AJ		No Equivalent Apparatus Code
NT8D80AL	QCAD123G	Equivalent Apparatus Code
NT8D80AP	QCAD123H	Equivalent Apparatus Code
NT8D80AZ		No Equivalent Apparatus Code
NT8D81AA		No Equivalent Apparatus Code
NT8D82AC	QCAD120	Equivalent Apparatus Code
NT8D82AD		No Equivalent Apparatus Code
NT8D83AC	QCAD317	Equivalent Apparatus Code

Table 26
New PEC to old apparatus code (Part 3 of 5)

New PEC	Old apparatus	Description
NT8D83AD	QCAD317	Equivalent Apparatus Code
NT8D84AA		No Equivalent Apparatus Code
NT8D85AB		No Equivalent Apparatus Code
NT8D85AC	QCAD124B	Equivalent Apparatus Code
NT8D85AD	QCAD124C	Equivalent Apparatus Code
NT8D85AE	QCAD124M	Equivalent Apparatus Code
NT8D85AF	QCAD124D	Equivalent Apparatus Code
NT8D85AJ		No Equivalent Apparatus Code
NT8D85AL	QCAD124F	Equivalent Apparatus Code
NT8D85AP	QCAD124G	Equivalent Apparatus Code
NT8D85AT	QCAD124H	Equivalent Apparatus Code
NT8D85AV	QCAD124J	Equivalent Apparatus Code
NT8D85AZ	QCAD124L	Equivalent Apparatus Code
NT8D86AC		No Equivalent Apparatus Code
NT8D86AD		No Equivalent Apparatus Code
NT8D87AC		No Equivalent Apparatus Code
NT8D88AC		No Equivalent Apparatus Code
NT8D88AD		No Equivalent Apparatus Code
NT8D89AX		No Equivalent Apparatus Code
NT8D90AF		No Equivalent Apparatus Code
NT8D91AC		No Equivalent Apparatus Code
NT8D91AD		No Equivalent Apparatus Code

Table 26
New PEC to old apparatus code (Part 4 of 5)

New PEC	Old apparatus	Description
NT8D91AE		No Equivalent Apparatus Code
NT8D91AF		No Equivalent Apparatus Code
NT8D91AG		No Equivalent Apparatus Code
NT8D91AJ		No Equivalent Apparatus Code
NT8D91AP		No Equivalent Apparatus Code
NT8D91AT		No Equivalent Apparatus Code
NT8D91AV		No Equivalent Apparatus Code
NT8D92AB		No Equivalent Apparatus Code
NT8D93AJ		No Equivalent Apparatus Code
NT8D93AW		No Equivalent Apparatus Code
NT8D95AJ	QCAD36	Equivalent Apparatus Code
NT8D95AT		No Equivalent Apparatus Code
NT8D95AW	QCAD37	Equivalent Apparatus Code
NT8D96AB	QCAD333	Equivalent Apparatus Code
NT8D97AX	QCAD133	Equivalent Apparatus Code
NT8D98AD		No Equivalent Apparatus Code
NT8D98AF		No Equivalent Apparatus Code
NT8D98AL		No Equivalent Apparatus Code
NT8D98AS		No Equivalent Apparatus Code
NT8D98AT		No Equivalent Apparatus Code
NT8D99AB	NE-A18QA	Equivalent Apparatus Code
NT8D99AC	NE-A18QA	Equivalent Apparatus Code

Table 26
New PEC to old apparatus code (Part 5 of 5)

New PEC	Old apparatus	Description
NT8D99AD	NE-A18QA	Equivalent Apparatus Code
NT9J93AD		No Equivalent Apparatus Code
NT9J94AB	NE-A25A	Equivalent Apparatus Code
NT9J95AJ		No Equivalent Apparatus Code
NT9J96AC	QCAD311A4	Equivalent Apparatus Code
NT9J96AD	QCAD311A5	Equivalent Apparatus Code
NT9J96AE	QCAD311A6	Equivalent Apparatus Code
NT9J96AG		No Equivalent Apparatus Code
NT9J96AH		No Equivalent Apparatus Code
NT9J96AJ		No Equivalent Apparatus Code
NT9J97AC		No Equivalent Apparatus Code
NT9J97AD		No Equivalent Apparatus Code
NT9J97AE		No Equivalent Apparatus Code
NT9J97AG		No Equivalent Apparatus Code
NT9J97AH		No Equivalent Apparatus Code
NT9J97AJ		No Equivalent Apparatus Code
NT9J98AC	QCAD311A1	Equivalent Apparatus Code
NT9J98AD	QCAD311A2	Equivalent Apparatus Code
NT9J98AE	QCAD311A3	Equivalent Apparatus Code
NT9J99AC		No Equivalent Apparatus Code
NT9J99AD		No Equivalent Apparatus Code
NT9J99AE		No Equivalent Apparatus Code

Index

A

AE modules, intra-module cabling, 28
apparatus codes, cross-reference to PECs (Product Engineering Codes), 117, 120

B

battery power, 43

C

cabinets for modules, 39
cable connectors, 14
cabling

- assignment tables, 83
- cross-reference from old apparatus codes to new PECs, 117, 120
- external equipment to I/O panel, 47
- inter- versus intra-module, 21
- inter-module external, 39
- inter-module internal, 31
- intra-module, 24
- routing options, 11
- system monitor, 35

column height recommendations for modules, 16
core modules

- cabling, 33
- described, 26

CPC codes, 61
CPU modules

- placement as bottom modules, 16

D

DC power, 43
documentation, related, 7

E

EMI noise avoidance, 11, 39
external equipment

- cabling to I/O panel, 47

F

full-group network modules

- described, 16

H

half-group network modules, 32

I

intergroup modules, placement, 16
inter-module versus intra-module cabling, 21
intra-module cabling, 21
I/O panels

- cabling to external equipment, 47
- described, 22
- Universal, 22

IPE modules

- intra-module cabling for, 24
- I/O connector panels, 25
- placement, 16

M

Meridian 1 systems

- module configurations available, 9
- related documentation, 7
- system types, 15

- upgrading, 16
- Meridian Link Module
 - cabling, connectors and slot assignment, 116
 - intra-module cabling, 28
- Meridian Mail modules
 - cabling to network modules, 45
 - intra-module cabling, 27
 - placement, 16
- modules
 - available for Meridian 1 systems, 9
 - column height recommendations, 16
 - See also* cabling

N

- network modules
 - cabling to another network module, 31
 - cabling to Meridian Mail, 45
 - intra-module cabling for, 24
 - junctur cabling, connectors and slot assignment, 115
 - placement, 16
- NT1R03 25DB M/F Extension Cable, 62
- NT1R03 25DB M/M Extension Cable, 62
- NT1R03 Max to IPE Modem Cable, 62
- NT1R03 Shielded 4 Port Cable, 61
- NT1R03 Shielded 4 Port with Ethernet Cable, 61
- NT1R03 Shielded LAM Extension Cable, 62
- NT1R04 Clock Controller to I/O Panel Cable, 62
- NT1R05 Intercabinet Module Cable, 62
- NT4R20 RSM Adapter Cable, 63
- NT6D39 CPU/Network Module
 - intra-module cabling, 24
- NT6D44 Meridian Mail module, 27
- NT6D4405 CRT Cable, 63
- NT6D4406 RSM Cable, 63
- NT6D4407 GSP Cable, 63
- NT6D4408 NVP Cable, 63
- NT6D4410 CSL Cable, 63
- NT6D4411 DVS Bus Node to Node Cable, 64
- NT6D4412 DVS Bus Internal Cable, 64
- NT6D4413 DVS Bus ESBC Terminator, 64
- NT6D4414 DVS Bus Node 1 to 2 Cable, 64
- NT6D4415 DVS Bus HABC Terminator, 64
- NT6D4416 DVS Bus, Node 2 to 3 Cable, 64
- NT6D54 QBL15 Field Wiring Kit (DC), 64
- NT6D60 Core Module, intra-module cabling, 26
- NT6P0110 Four-Port Cable, 64
- NT7D18 AE Module, intra-module cabling, 28
- NT7D19 Meridian Link Module
 - cabling, connectors and slot assignment, 116
- NT7D61Ax VME SDI I/O Intercable, 65
- NT7D89 RS-232 to I/O Panel Cable, 65
- NT7D90 Ethernet to I/O Panel Cable, 65
- NT7D94 VME Transceiver Cable, 65
- NT7D95 VME Transition Cable, 65
- NT8D22 System Monitor, cabling, 35
- NT8D34 CPU Module
 - cabling, connectors and slot assignment, 83
- NT8D35 Network Module
 - cabling to another network module, 31
 - cabling, connectors and slot assignment, 114
 - intra-module cabling, 24
- NT8D36 InterGroup Module, 32
- NT8D37 IPE Module, 86, 88, 90
 - intra-module cabling, 24
 - SL1 loop cabling, connectors and slot assignment, 111
 - SL2 loop cabling, connectors and slot assignment, 112
 - SL3 loop cabling, connectors and slot assignment, 113
 - SLO loop cabling, connectors and slot assignment, 110
- T&R Cable E cabling, connectors and slot assignment, 92
- T&R Cable F cabling, connectors and slot assignment, 94
- T&R Cable G cabling, connectors and slot assignment, 96
- T&R Cable K cabling, connectors and slot assignment, 98
- T&R Cable L cabling, connectors and slot assignment, 100

-
- T&R Cable M cabling, connectors and slot assignment, 102
 - T&R Cable R cabling, connectors and slot assignment, 104
 - T&R Cable S cabling, connectors and slot assignment, 106
 - T&R Cable T cabling, connectors and slot assignment, 108
 - NT8D46AA System Monitor Stack Cable, 65
 - NT8D46AB System Monitor Jumper Cable, 66
 - NT8D46AD System Monitor Quad Serial Data Interface Cable, 66
 - NT8D46AF System Monitor Remote Serial Data Interface Cable, 66
 - NT8D46AG System Monitor to Extended Serial Data Interface Cable, 66
 - NT8D46AJ UPS Alarm Cable (AC), 66
 - NT8D46AK UPS Alarm Cable (AC), 66
 - NT8D46AL System Monitor Serial Link Cable, 66
 - NT8D46AN XDF to PFT Cable, 67
 - NT8D46AP System Monitor Serial Link Cable, 67
 - NT8D46AQ UPS Alarm Cable (AC), 67
 - NT8D46AS System Monitor Inter-CPU Cable, 67
 - NT8D46AT System Monitor/QBL15 Cable (DC), 67
 - NT8D46AU UPS Alarm Cable (AC), 67
 - NT8D46AV System Monitor/QCA13 Cable (DC), 67
 - NT8D46AW System Monitor/QBL12 Cable (DC), 67
 - NT8D46AX System Monitor CE/PE ST Upgrade Cable, 68
 - NT8D46AY System Monitor XPE ST Upgrade Cable, 68
 - NT8D46BA ST Upgrade QCA136 Internal Cable, 68
 - NT8D46BB ST Upgrade QCA136 Internal Cable with Expansion, 68
 - NT8D46BC ST Upgrade QCA137 External Cable, 68
 - NT8D46BD ST Upgrade QCA136 External Adapter Cable, 68
 - NT8D46BE ST Upgrade QCA136 External Cable, 68
 - NT8D46BF ST/RT Upgrade System Monitor External Adapter Cable, 68
 - NT8D46BG RT Upgrade QCA147 Internal Cable, 69
 - NT8D46BH System Monitor to MDF Cable, 69
 - NT8D46BJ Upgrade QCA147 Internal Cable with Expansion, 69
 - NT8D46BK RT Upgrade QCA137 External Cable with Expansion, 69
 - NT8D46BL RT Upgrade QCA147 w/Expnsn Ext. Adapter Cable, 69
 - NT8D46BM ST Upgrade QCA136 w/Expnsn Ext. Adapter Cable, 69
 - NT8D46CD System Monitor to AEM Cable, 69
 - NT8D46CH RT Upgrade QCA147 External Cable, 70
 - NT8D46DH/EH System Monitor to MDF Cable, 70
 - NT8D46FH System Monitor to SL-100 Cable, 70
 - NT8D7205 PRI to I/O Panel Cable, 70
 - NT8D73 Network I/O to Network I/O Intercabinet Cable, 70
 - NT8D74 Clock Controller to Junctor Cable, 70
 - NT8D75 Clock Controller to Clock Controller Cable, 70
 - NT8D76 InterGroup Switch to Junctor Cable, 71
 - NT8D77 Floppy Disk Interface to Floppy Drive Unit Cable, 71
 - NT8D78 CPU Cable, 71
 - NT8D79 DTI to Clock Controller Cable, 71
 - NT8D80 CPU Interface Cable, 72
 - NT8D81 B/P Tip and Ring to I/O Cable, 72
 - NT8D82 SDI to I/O Cable, 72
 - NT8D83 DTI to I/O Cable, 72
 - NT8D84 XSDI to I/O Cable, 72
 - NT8D85 Network to PE Cable, 73
 - NT8D86 Network to I/O Cable, 73
 - NT8D88 Superloop Network Card to I/O Cable, 73
 - NT8D90 SDI Multiple Port Extension Cable, 73
 - NT8D91 Superloop Network to Peripheral Controller Cable, 74
 - NT8D92 I/O to Peripheral Controller Cable, 74
-

NT8D93 XSDI I/O to DTE or DCE Cable, 74
NT8D95 SDI I/O Panel to DTE or DCE Cable, 74
NT8D96 SDI Multiple Port Cable, 74
NT8D98 Superloop Network I/O to Superloop
Network I/O Intercabinet Network Cable,
75
NT8D99 CPU to Network Cable, 75
NT9J93 DTI Echo Canceler to I/O Cable, 76
NT9J94 RPE to I/O Cable, 76
NT9J95 Peripheral Controller Maintenance Cable,
76
NT9J96 Network to I/O Intracabinet Network
Cable, 76
NT9J97 Superloop Network to I/O Intracabinet
Network Cable, 77
NT9J98 Network to ST I/O Intracabinet Network
Cable, 77
NT9J99 Superloop Network to ST I/O Intracabinet
Network Cable, 77
NTAK0410 Battery Cable, 77
NTAK19 SDI 2 Port Cable, 77
NTBK04 1.5MB Carrier/Clock Cable, 78
NTBK04 1.5MB DTI/PRI Carrier Cable, 78
NTBK04 1.5MB DTI/PRI T1 Cable, 77
NTBK05 2MB DTI/PRI Coax Carrier Cable, 78
NTBK05 SDT12 120-OHM E1 Cable, 78
NTND11 CMB to CMB Cable, 78
NTND13 SCSI Cable, 78
NTND14 CNI to 3PE Cable, 79
NTND26 MDSL to DCHI Cable, 79
NTND27 MSDL SDI/AM2 Cable, 79
NTND27 MSDL to I/O Panel Cable, 79
NTND28 Network Expansion Intercabinet Cable,
79
NTND29 Network Expansion CPU Interface Cable,
80
NTND30 Network Expansion Junctor to I/O
Housing Cable, 80
NTND37 Dual SDI Cable, 80
NTND71 BRA Clock Reference to Clock Controller
Cable, 80
NTND72 Clock Reference to Clock Controller
Cable, 80

NTND82 Printer to LIU Cable, 80
NTND91 CSL Cable, 80
NTND91 Extension-25DB Cable, 81
NTND94 Cable, 81
NTND94 CNI to I/O Panel Cable, 81
NTND95 EMI Box to 3PE Cable, 81

O

option 51/51C
described, 15
option 61/61C
described, 15
upgrade to option 81, 49
option 71
upgrade to option 81, 49
option 81
configuration, 20
described, 15
upgrading from option 61/61C, 49
upgrading from option 71, 49

P

P0715058 Universal I/O panel, 22
PE modules
cabling to network modules, 33
PEC (Product Engineering Code), 61
cross-reference from old apparatus codes, 117,
120
printers, cabling to I/O panel, 47

Q

QCAD309 Cable, 61
QCAD328 DCHI Interface Cable, 61

R

RFI noise avoidance, 11, 39
routing options for cabling, 11

S

SL-1 systems, upgrading to Meridian 1 systems, 55
system monitors, cabling, 35, 42

T

- T&R Cable A cabling, connectors and slot assignment, 86
- T&R Cable B cabling, connectors and slot assignment, 88
- T&R Cable C cabling, connectors and slot assignment, 90
- terminals
 - cabling to I/O panel, 47

U

- UEMs (universal equipment modules), 9
 - See also* modules
- Universal I/O panels, 22
- upgrading, 16
- UPS (uninterruptible power supply) units, 43

Meridian 1

Cabling Guide

Copyright © 1994– 2000 Nortel Networks

All Rights Reserved

Information is subject to change without notice. Nortel Networks reserves the right to make changes in design or components as progress in engineering and manufacturing may warrant. This equipment has been tested and found to comply with the limits for a Class A digital device pursuant to Part 15 of the FCC rules, and the radio interference regulations of Industry Canada. These limits are designed to provide reasonable protection against harmful interference when the equipment is operated in a commercial environment. This equipment generates, uses and can radiate radio frequency energy, and if not installed and used in accordance with the instruction manual, may cause harmful interference to radio communications. Operation of this equipment in a residential area is likely to cause harmful interference in which case the user will be required to correct the interference at their own expense.

SL-1 and Meridian 1 are trademarks of Nortel Networks.

Publication number: 553-3001-109

Document release: Standard 6.00

Date: April 2000

Printed in Canada



How the world shares ideas.