Meridian 1

System Installation Procedures

Document Number: 553-3001-210
Document Release: Standard 16.00
Date: January 2002

Copyright © 1990–2002 Nortel Networks
All Rights Reserved

Printed in Canada

Information is subject to change without notice. Nortel Networks reserves the right to make changes in design or components as progress in engineering and manufacturing may warrant. This equipment has been tested and found to comply with the limits for a Class A digital device pursuant to Part 15 of the FCC rules, and the radio interference regulations of Industry Canada. These limits are designed to provide reasonable protection against harmful interference when the equipment is operated in a commercial environment. This equipment generates, uses and can radiate radio frequency energy, and if not installed and used in accordance with the instruction manual, may cause harmful interference to radio communications. Operation of this equipment in a residential area is likely to cause harmful interference in which case the user will be required to correct the interference at their own expense.

SL-1 and Meridian 1 are trademarks of Nortel Networks. Intel and Pentium are trademarks of Intel Corporation. cPCI is a trademark of PCI Industrial Computer Manufacturers Group. Hilti is a trademark of the Hilti Corporation. Ramset and RedHead are trademarks of ITW Ramset/RedHead and Illinois Tool Works Inc. IBDN and BIX are trademarks of NORDX/CDT Inc.

Revision history

January 2002

Standard 16.00. This document is up-issued to support Meridian 1 Release 25.40 systems. This document is up-issued to include Call Processor Pentium (CP PII) and Fibre Network Fabric (FNF) for Option 81C.

April 2000

Standard 15.00. This is a global document and is up-issued for X11 Release 25.0x. Document changes include removal of: redundant content; references to equipment types except Options 11C, 51C, 61C, and 81C; and references to previous software releases.

June 1999

Standard, release 14.00. Includes references to the new 68060E NT5D03 Call Processor card, and the new AC and DC PDUs.

October 1997

Standard, release 13.00. Includes references to the new 68060 NT5D10 Call Processor and NT5D61 IODU/C cards. Changes are noted by revision bars in the margins.

August 1996

Standard, release 12.00. Reissued for technical content. Includes references to the new NT9D19 48 MB Call Processing Card and a new procedure to install software. Changes to technical content are noted by revision bars in the margins.

December 1995

Standard, release 11.00. Reissued for technical content. Includes information on System 600/48 Power Plant.

July 1995

Standard, release 10.00. Reissued to include international information to create a global NTP, Option 81, Option 81C, and minor text and graphic changes. Changes to technical content are noted by revision bars in the margins.

December 1994

Standard, release 9.00. Reissued for technical content.

December 1994

Standard, release 8.00. This document is reissued to include updated information on the Small systems Multi-Disk Unit (SMDU), Option 51C, NTND01CA 12MB ICM card. Changes to technical content are noted by revision bars in the margins.

April 1994

Standard, release 7.00. New information and changes to technical content are noted by revision bars in the margins.

August 1993

Standard, release 6.00. New information and changes to technical content are noted by revision bars in the margins.

April 1993

Standard, release 5.00. Due to the extent of the changes, revision bars are not used.

December 1992

Standard, release 4.00. New information and changes to technical content are noted by revision bars in the margins.

December 1991

Standard, release 3.00. This document is reissued to include technical content updates. Due to the extent of the changes, revision bars are not used.

February 1990

Standard, release 2.00.

January 1990

Standard, release 1.00.

Contents

About this document	7
Introduction	9
Initial Meridian 1 installation	15
Preparing equipment for installation	21
Placing the fourth module on a column	29
Positioning and leveling equipment	33
Installing overhead cable tray kits	37
Installing AC power	39
Installing DC power	49
Planning and designating the Modular Distribution Frame (MDF)	71
Installing PFTUs	87
Configuring the system monitor	93
Connecting a system terminal (or modem)	105
Cabling common equipment	123

Cabling network modules and loops	157
Cabling lines and trunks	185
Powering up the system and initial loading	221
Performing acceptance tests	247
Installing earthquake bracing	257
Adding a module to a column	275
Appendix A: NT0R72, NT6D82, QBL12, QBL15, QCA13	295
Appendix B: Backplane cabling in NT8D37 modules	339
Appendix C: Customer supplied power equipment	361
List of terms	369
Index	377

About this document

This document applies to Meridian 1 Internet Enabled systems.

This document is a global document. Contact your system supplier or your Nortel Networks representative to verify that the hardware and software described is supported in your area.

This document provides installation and acceptance testing procedures for Meridian 1 system Options 51C, 61C, and 81C.

Who should use this document

This document is intended for individuals responsible for System installation.

How this document is organized

To use this document, you should have a basic knowledge of Meridian 1 equipment and operation. (Contact Nortel Networks Training Centers for information on installation courses.) You should also read and fully understand the *System Overview* (**553-3001-100**) before you install a system.

Introduction

Content list

This section contains information on the following topics:

Meridian 1 equipment	9
Equipment handling precautions	10
Unloading equipment	11
Power equipment	11
Circuit cards	11
Cable routing guidelines	12

Meridian 1 equipment

In Meridian 1 systems, modules are stacked one on top of another to form a column. Each column contains a pedestal, a top cap, and up to four modules that can include the:

- NT5D21 Core/Network Module
required for Options 51C, and 61C
- NT4N41 cPCI[®] Core/Network Module
required for Options 81C
- NT8D35 Network Module
required for Option 81C
- NT8D37 Intelligent Peripheral Equipment (IPE) Module
required for Options 51C, 61C, and 81C

In addition, modules that house application specific equipment, such as Meridian Mail and Meridian Link modules, can be included in a column.

Each pedestal houses a blower unit, air filter, power distribution unit (PDU), and system monitor.

The top cap provides airflow exits, input/output (I/O) cable access, and overhead cable-rack mounting. Thermal sensor assemblies for the column are attached to a perforated panel, which is placed on top of the highest module in the column, under the top cap.

A system can have one column or multiple columns. For compliance with EMI/RFI standards, spacer kits are provided to interconnect the columns in a multiple-column system.

The procedures in this document apply to the following system options:

- Option 51C: enhanced common control complex with single CPU, half network group
- Option 61C: enhanced common control complex with dual CPU, full network group
- Option 81C: enhanced common control complex with dual CPU, multiple network groups

All system options are available in both AC- and DC-powered versions.

Meridian 1 system architecture and each type of module are described in *System Overview* (553-3001-100). The components of AC-powered systems, DC-powered systems, and reserve power options for both are described in *Power Engineering* (553-3001-152).

Equipment handling precautions

To avoid personal injury and equipment damage, review the following guidelines before handling Meridian 1 equipment.

Unloading equipment

Special ramps, packed inside the pallet holding Column 0, must be used to move the equipment off the pallet. Follow the instructions provided with the ramps.



CAUTION

Damage to Equipment

Never pry up the pedestal to lift the column. This could cause major damage to the pedestal. Manually slide the column down the ramps provided.

Power equipment

There are no user-repairable components in the power system. If a power supply fails, the complete unit must be replaced. Do *not* disassemble a power supply under any circumstances.



DANGER OF ELECTRIC SHOCK

To avoid the danger of electric shock, be very careful when you work with power equipment and connections. Warning notices are displayed and *must* be heeded.

External power equipment, such as a UPS, power plant, or batteries, may be very heavy and may require special handling procedures and additional personnel for unloading and installation. Also, be aware of weight distribution and keep the equipment room floor from being overly stressed.

Circuit cards

Handle cards as follows:

- Unpack or handle cards away from electric motors, transformers, or similar machinery.
- Handle cards by the edges only. Do not touch the contacts or components.

- Set cards on a protective antistatic bag. If an antistatic bag is not available, hand-hold the card, or set it in a card cage unseated from the connectors.
- Store cards in protective packing. Do not stack cards on top of each other unless they are packaged.

To avoid card damage from static discharge, wear a properly connected antistatic wrist strap when you work on Meridian 1 equipment. If a wrist strap is not available, regularly touch one of the bare metal strips in the module to discharge static. Figure 1 on page 12 shows connection points for the wrist strap and the bare metal strips you should touch.

Figure 1
Static discharge points

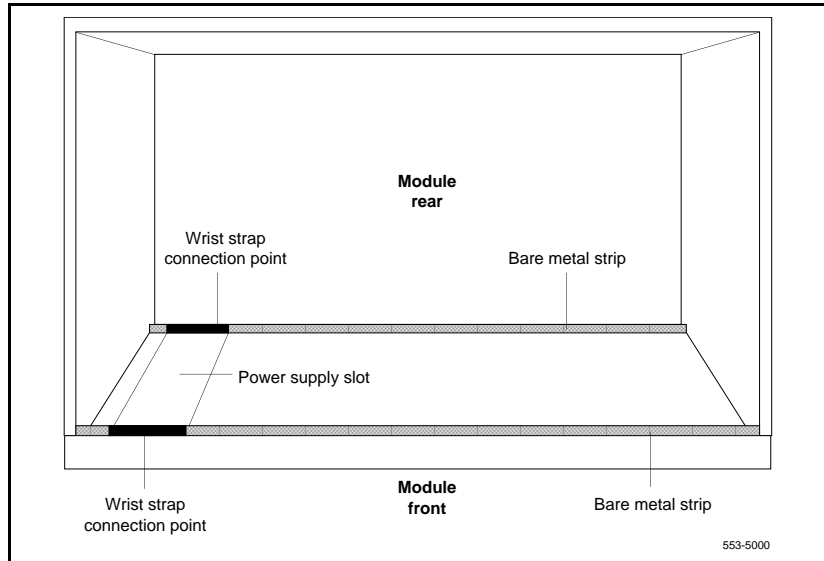

Cable routing guidelines

A system layout, preconfigured at the factory, is included in the software box with each system shipment. Before you route cables, refer to the “to-from” cable connections in the system layout. Note that there are a variety of cable lengths. Make sure you install the designated cable for each connection.

Because the cable troughs (see Figure 2 on page 14) and spaces on the sides of each module are within the EMI shielding of the system, unshielded cables can be routed in those areas. The corner vertical channels in the rear of the module are outside of the EMI shield. Cables routed in the vertical channels must be shielded, and must enter and exit the EMI-shielded area through I/O panels and adapters.

As space permits, cables can be routed

- horizontally in the cable troughs at the front, rear, and sides of the module

Note: In a DC-powered module, because there is no MPDU, there is room to route cables horizontally from front to rear on the left side (front view) of the module.

- vertically on the sides of the module

vertically in the corner channels in the rear of the module (shielded cables only).



CAUTION

Damage to Equipment

Cables must be routed as perpendicular as possible to any nearby power cables. Avoid routing cables near power cables if alternate routing is available. (At the rear of the module, cables routed between the I/O panel and the rear cover can be parallel to the power cables because the panel provides EMI shielding.)

Figure 2
Cable routing troughs—front view of module

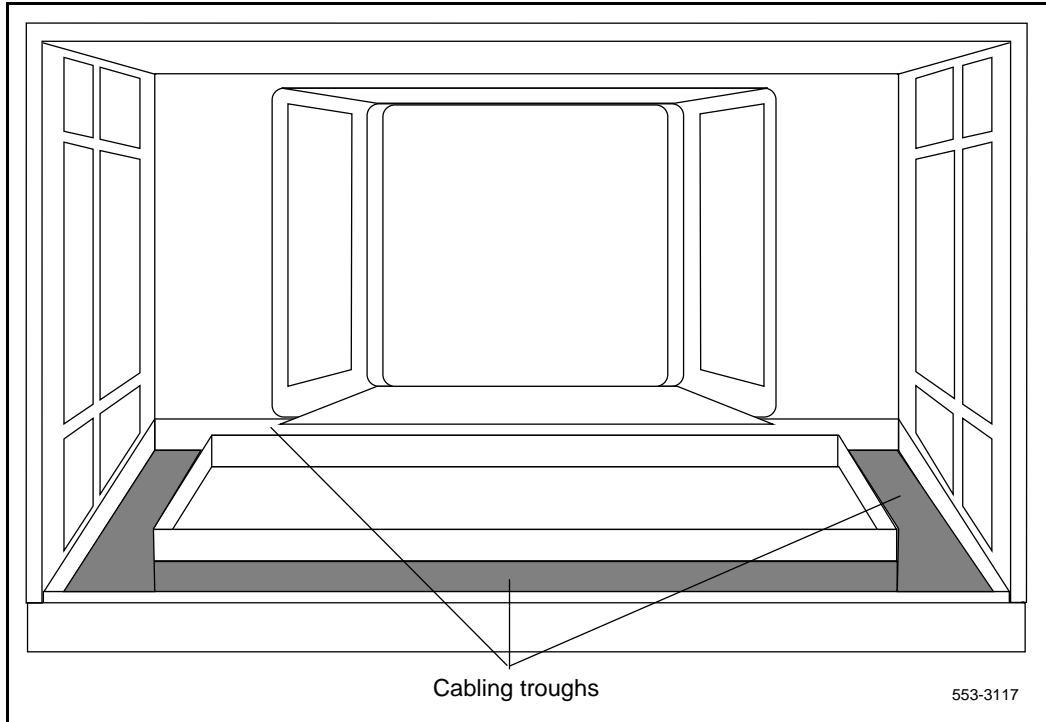

Initial Meridian 1 installation

Content list

The following are the topics in this section:

Reference list	15
Requirements	15
System installation procedures	16

Reference list

The following are the references in this section:

- *Installation Planning* (553-3001-120)
- *Telephone and Attendant Console: Installation* (553-3001-215)
- *Hardware Upgrade Procedures* (553-3001-258)
- *Circuit Card: Installation and Testing* (553-3001-211)

Requirements

Before Meridian 1 equipment is delivered to the installation site, you must consider

- fire protection and safety requirements
- equipment room requirements
- grounding and power requirements
- cable requirements

Specifications for these requirements and for developing the equipment room floor plan are provided in *Installation Planning* (553-3001-120).

For proper installation, perform the steps in this procedure in the order given. If you go to a subsection to perform a step, return to the next step in this procedure when the tasks in the subsection are completed. For example, when you complete Step 3 “position and level equipment,” return to Step 4 in this procedure. See Table 1 on page 19 for a list of tasks in subsections.

Whenever possible, install external power equipment before the system installation. If reserve power equipment is used, install it according to the manufacturer’s instructions.

To install telephones and attendant consoles, see *Telephone and Attendant Console: Installation* (553-3001-215).

System installation is to be performed by qualified personnel only.

System installation procedures

- 1 Prepare equipment for installation; go to “Preparing equipment for installation” on page 21.
- 2 Place the fourth module on a column (if required); go to “Placing the fourth module on a column” on page 29.
- 3 Position and level equipment; go to “Positioning and leveling equipment” on page 33.
Note: If earthquake bracing is required, go to “Installing earthquake bracing” on page 257 to install column and floor bracing and to position and level equipment. When those procedures are complete, return to Step 4 or Step 5 (as applicable) in this procedure.
- 4 Install overhead cable tray kits (if required); go to “Installing overhead cable tray kits” on page 37.
- 5 Install power supplies in all modules:
 - a. Make sure the system is disconnected from any power source.
 - b. Set switches and breakers on all module power supplies or module power distribution units (MPDUs) to OFF.
 - c. Insert each power supply into the appropriate card cage and hook the locking devices.

- 6** Install the disk drive unit in a Core/Net Module, for Options 51C, and 61C. Install the cPCI Multi-Media Disk Unit in a cPCI Core/Net Module, for Option 81C.
- Note:** In the Option 61C there are two disk drive units. Install a disk drive unit in each Core/Network. In the Options 81C there are two cPCI Multi-Media Disk Units. Install a cPCI Multi-Media Disk Unit in each cPCI Core/Network.
- 7** Install power equipment and ground wiring:
- For AC-powered systems, go to “Installing AC power” on page 39.
 - For DC-powered systems, go to “Installing DC power” on page 49.
- 8** Plan and designate the main distribution frame (MDF); go to “Planning and designating the Modular Distribution Frame (MDF)” on page 71.
- 9** Install power fail transfer units (PFTUs) (if required); go to “Installing PFTUs” on page 87.
- 10** Configure the system monitor; go to “Configuring the system monitor” on page 93.
- 11** Connect a system terminal (or modem); go to “Connecting a system terminal (or modem)” on page 105.
- 12** Install cabling:
- To cable common equipment, go to “Cabling common equipment” on page 123.
 - To cable network loops, go to “Cabling network modules and loops” on page 157.
 - To cable IPE Modules to the MDF and to connect lines and trunks, go to “Cabling lines and trunks” on page 185.
- 13** Power up the system and load the system software; go to “Powering up the system and initial loading” on page 221. However, if you are upgrading your system, do not install new software, but return to the upgrade procedures in *Hardware Upgrade Procedures* (553-3001-258).

- 14 Perform acceptance tests; go to “Performing acceptance tests” on page 247.

Note: To test circuit cards, see “Acceptance tests” in *Circuit Card: Installation and Testing* (553-3001-211). To test telephones and attendant consoles, see *Telephone and Attendant Console: Installation* (553-3001-215).

- 15 Replace all covers and grills on the front and rear of the system.

Table 1
Initial system installation—list of tasks in subsections

Task	Go to
Prepare equipment for installation	page 21
Place the fourth module on a column	page 29
Position and level equipment	page 33
Install overhead cable tray kits	page 37
Install power supplies in all modules*	—
Install the disk drive unit(s)*	—
Install power equipment and ground wiring	
AC power	page 39
DC power	page 49
Plan and designate the MDF	page 71
Install PFTUs	page 87
Configure the system monitor	page 93
Connect a system terminal (or modem)	page 105
Cable common equipment	page 123
Cable network loops	page 157
Cable lines and trunks	page 185
Power up the system and load system software	page 221
Perform acceptance tests	page 247
* See "System installation procedures" on page 16 and 2-3 for details on tasks that are not described in subsections.	

Preparing equipment for installation

Content list

The following are the topics in this section:

Reference list	21
Equipment room floor plan	21
Universal Equipment Modules	22
UEMs are stacked in columns	22
Columns are grouped together in rows	23
UEMs are identified by function	24
The card cage	25

Reference list

The following are the references in this section:

- *Installation Planning* (553-3001-120)
- *Circuit Card: Installation and Testing* (553-3001-211)

Equipment room floor plan

Use the equipment room floor plan to position equipment. See *Installation Planning* (553-3001-120) to prepare the equipment room and floor plan.



WARNING

A fully loaded column weighs 274.4 kg (605 lbs). More than one person is required to remove equipment from shipping pallets.



WARNING

Module covers are *not* hinged; do not let go of the cover. Lift the cover away from the module and set it out of the work area.

Universal Equipment Modules

Universal Equipment Modules (UEMs) are the building blocks of the Meridian 1 communications system. Each UEM is a generic case containing sets of equipment used in Meridian 1 operations. See Figure 3 on page 23.

UEMs are stacked in columns

UEMs are stacked in columns, up to four modules high. These UEMs are numbered 0 to 3 from the bottom up. See Figure 3 on page 23.

Pedestals

Each column sits on a pedestal that contains power, cooling and monitoring equipment, as follows:

- A Power Distribution Unit (PDU) in the back of the pedestal supplies either AC or DC power to the column.
- A System Monitor checks the column's cooling and power systems.
- A blower unit (accessible from the front of the pedestal) forces air up through the modules to cool the circuit cards.

Top Caps

A top cap is mounted on the top module of each column, and contains the following:

- Air exhaust grills in the cap that release air from the blowers in the pedestal.
- A heat sensor that monitors the temperature of the column.
- A red LED in the front of the cap's exhaust grill that lights if the system overheats or if a power outage occurs.

Figure 3
Universal Equipment Modules

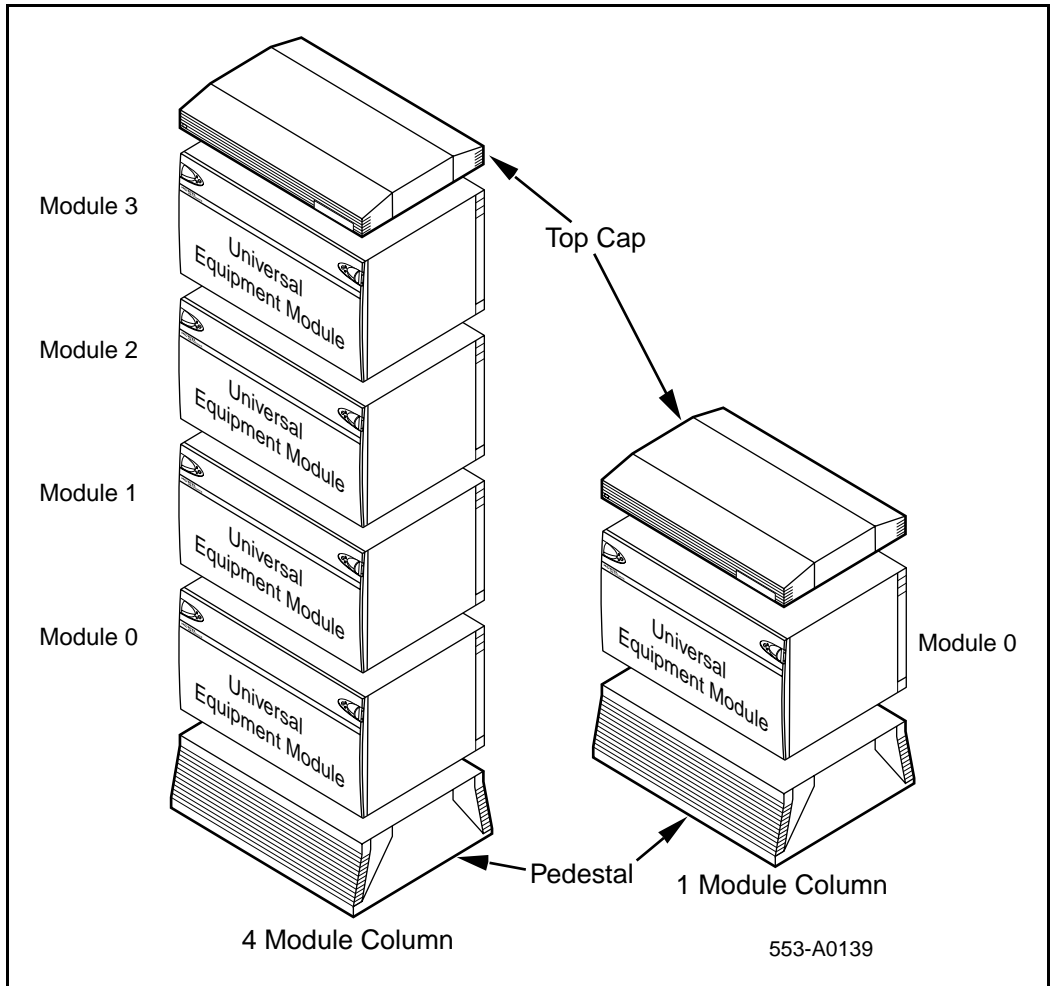

- Ladder racks for routing cables, can also be fitted to the top caps.

Columns are grouped together in rows

Columns are attached in rows. Column 0 is always the Column containing the “Core/Net 0” module. Column 1 is placed to the left of Column 0 and ALWAYS contains the “Core/Net 1” module.

Column 0 and Column 1 are placed at the far left of the row (front view).
Column numbering continues to the right of Core 0. See Figure 4 on page 24.

Additional rows are configured with the lowest numbered column on the far left and the highest numbered column on the far right (front view).

Figure 4
Column row

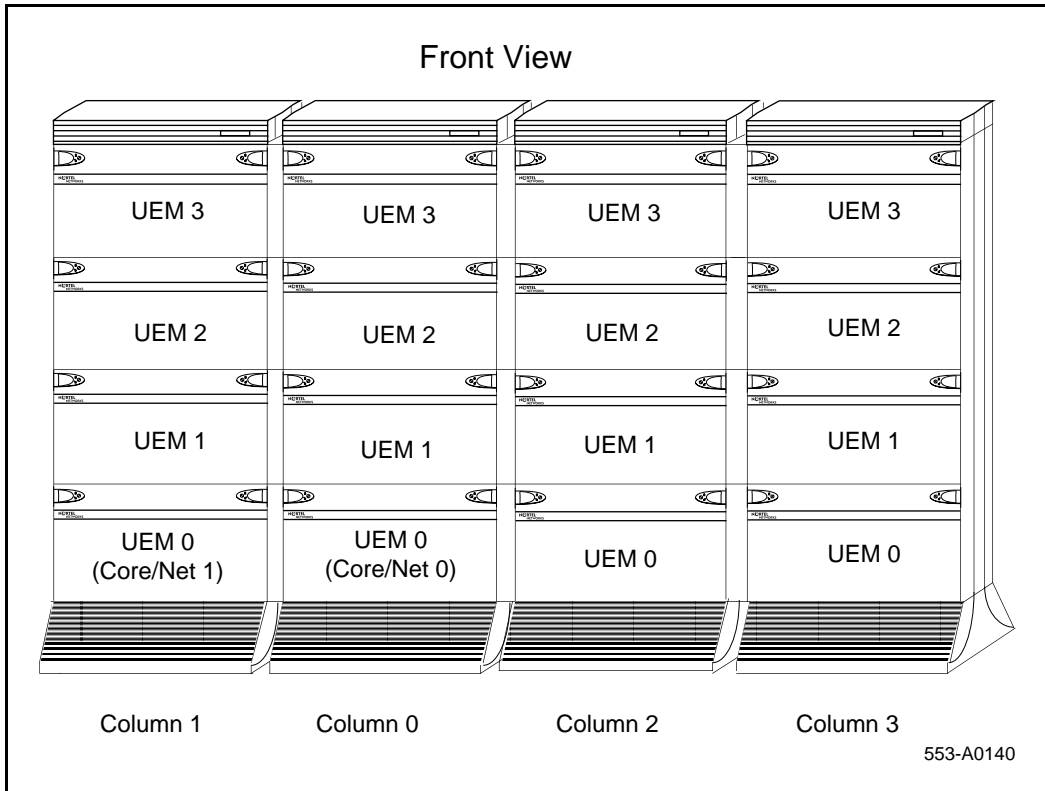

UEMs are identified by function

Each UEM contains a specialized set of equipment to digitalize, process, and route phone calls and voice messages.

Figure 5
UEMs identified by function

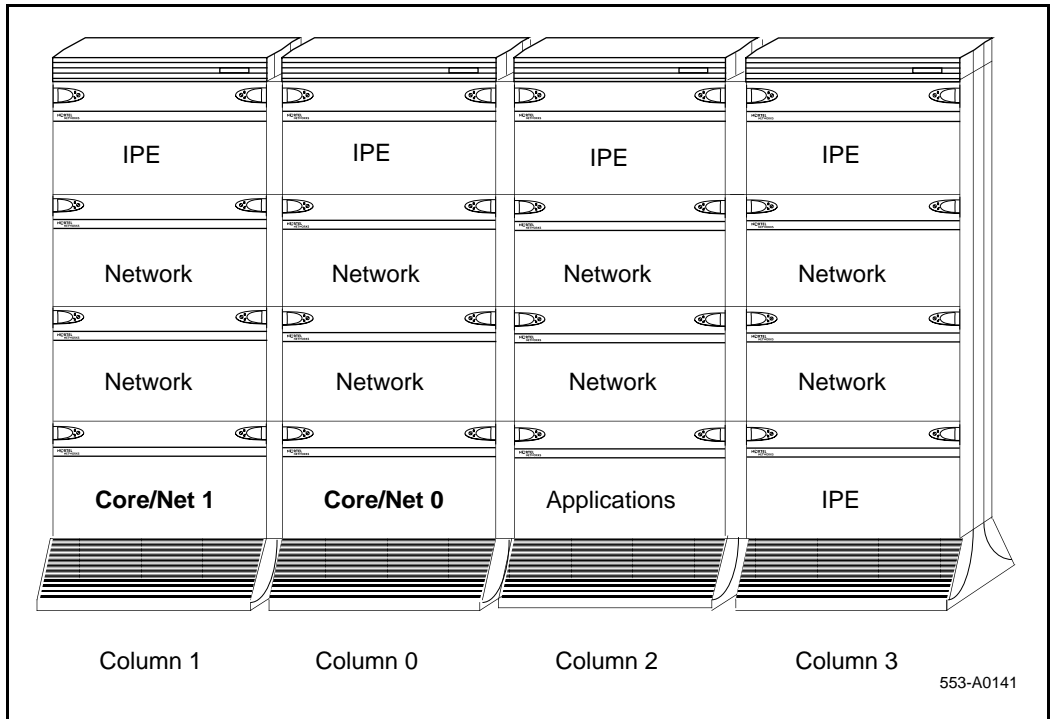

The card cage

Inside each UEM is a metal card cage. This card cage holds the circuit cards, power card and related equipment for that module. UEMs are named for the function of that card cage.

Card cages are bolted inside the UEM case and can be removed and replaced for repairs or upgrades.

- 1 Remove equipment from the shipping pallets; follow the unpacking instructions that come with the packaging material.
- 2 Remove the front and rear covers from each module:
 - a. With a flat blade screwdriver, turn the lock clockwise on the two locking latches (see Figure 6 on page 26).

- b. Simultaneously push the latches toward the center of the cover and pull the cover toward you while lifting it away from the module.
- c. Set the covers aside until the installation is complete.

Figure 6
Locking latches on the module cover

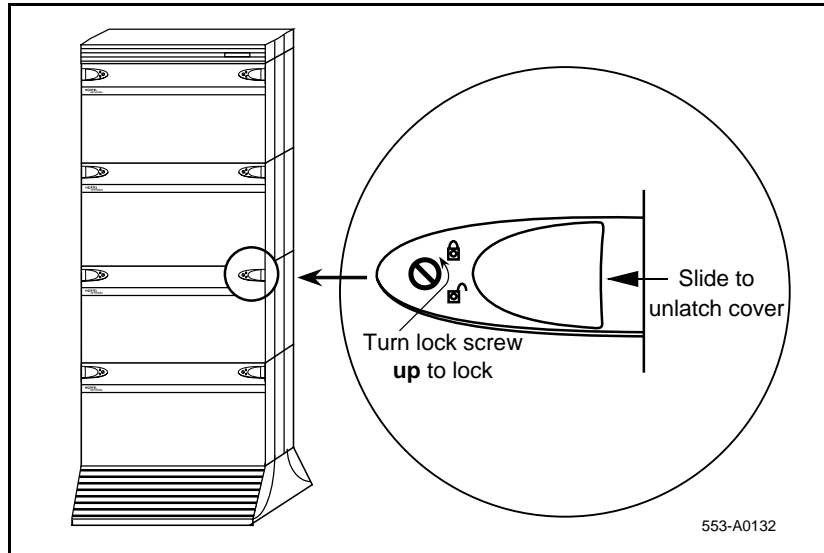

- 3 Remove the front and rear grills from each pedestal:
 - a. Loosen the two captive screws that secure the grill.
 - b. Pull the grill forward and lift it out of the base of the pedestal (see Figure 7 on page 27).
 - c. Set the grills aside until the installation is complete
- 4 Make sure all of the items on the system order form are on the packing slip that comes with the equipment.
- 5 Inspect all equipment for physical damage. Report any damage to your supplier.

Figure 7
Removing the pedestal grill

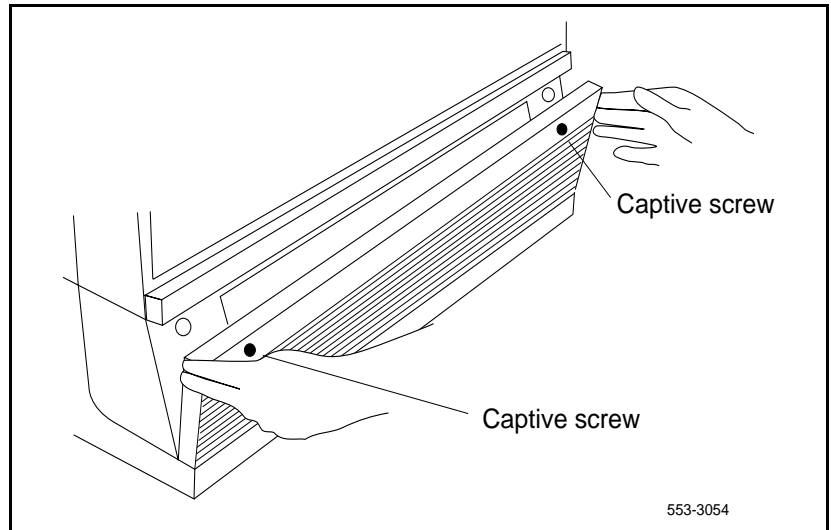

- 6 Check the option settings on all cards that have a switch symbol on the faceplate. For a list of all option switch and jumper settings, refer to *Circuit Card: Installation and Testing* (553-3001-211).

Note: In Options 51C, 61C, and 81C, there is a single jumper in the NT5D21 Core/Network Module. The jumper is located on the front of the backplane behind card slot 14 (see Figure 8 on page 28).

- Verify that the jumper is closed (there is a plug over both pins).

Figure 8
Location of the backplane jumper in the NT5D21 Core/Network Module
(Options 51C, 61C, and 81C)

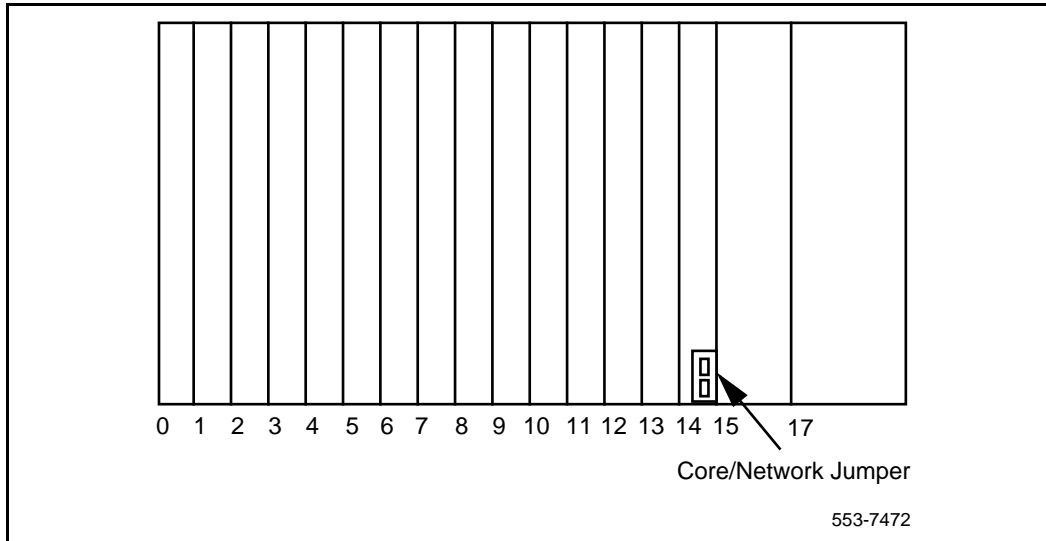

Placing the fourth module on a column

A four-module column is shipped in two segments. One shipping pallet carries the pedestal and three modules. Another shipping pallet carries the fourth module and top cap. Starting at the bottom of the column, modules are numbered from zero to three in each column. Use this procedure to place the fourth module (and top cap) on the column.

**CAUTION**
System Failure

Never add a common equipment module in the third or the fourth tier in an Meridian 1 column.

To add a module to a column that is already powered, see the procedures in “Adding a module to a column” on page 275.

**WARNING**

A fully loaded module weighs approximately 58.9 kg (130 lbs). More than one person is required to place a module on a column.

- 1 Position and secure the fourth module:
 - a. Locate the positioning guides on the third module (see Figure 9 on page 30).
 - b. Position the fourth module so it faces the same direction as the column.
 - c. Remove the front and rear module covers on the fourth module and rear module cover on the third module.

- d. Place the fourth module on top of the column and adjust it until it is seated securely on the positioning guides.
- e. Remove the I/O safety panel in the fourth module to gain access for installing the center mounting bolt.
- f. Use a 9/16-in. socket wrench to secure the fourth module with five mounting bolts (see Figure 10 on page 31).

Figure 9
Module positioning guides

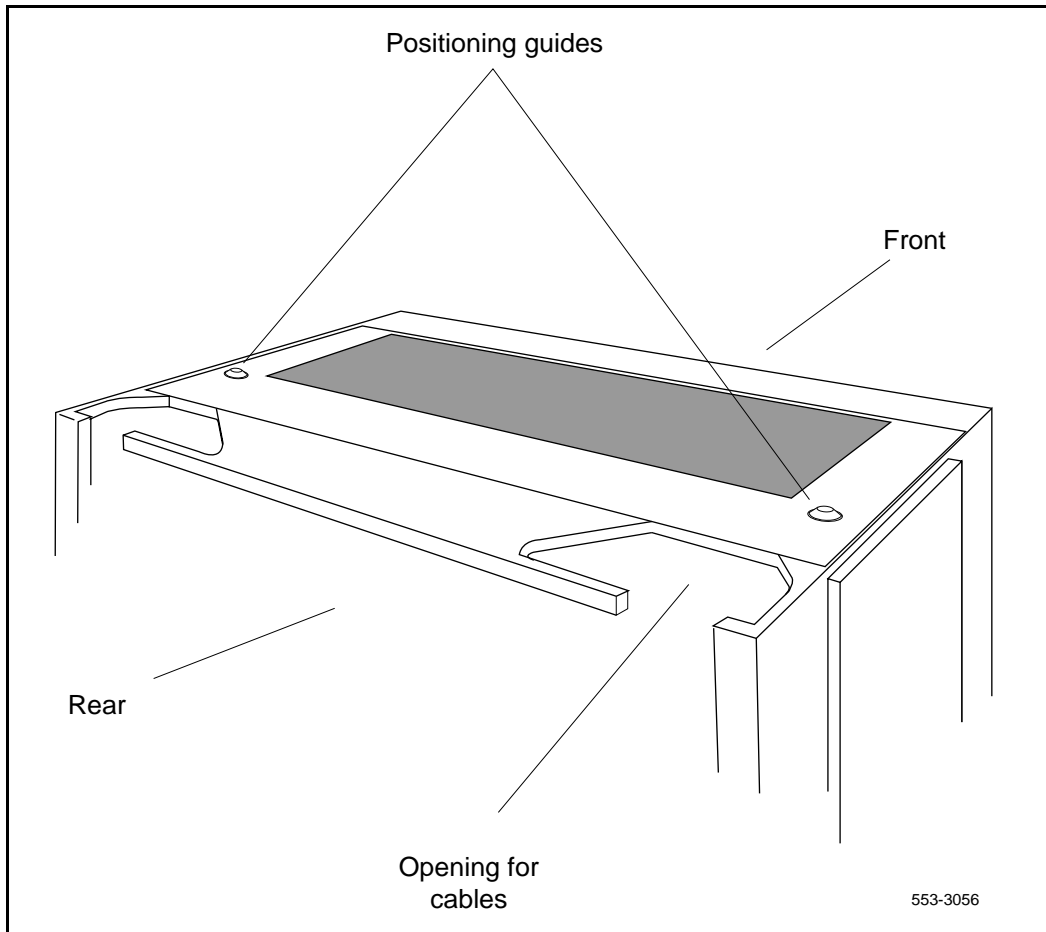
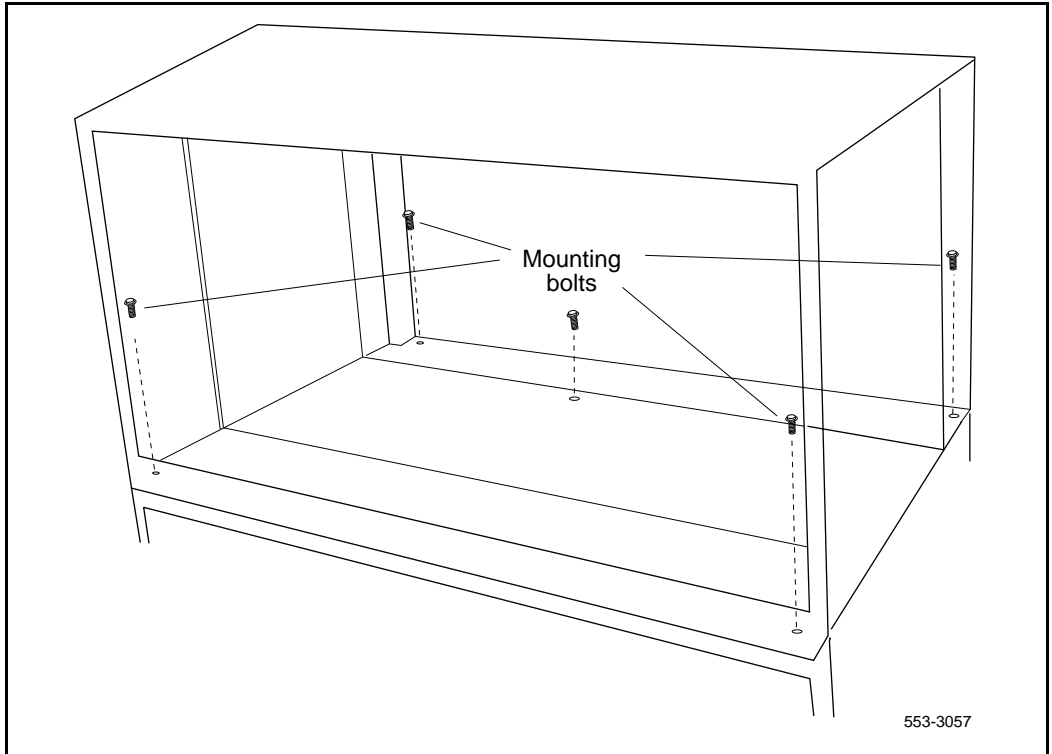
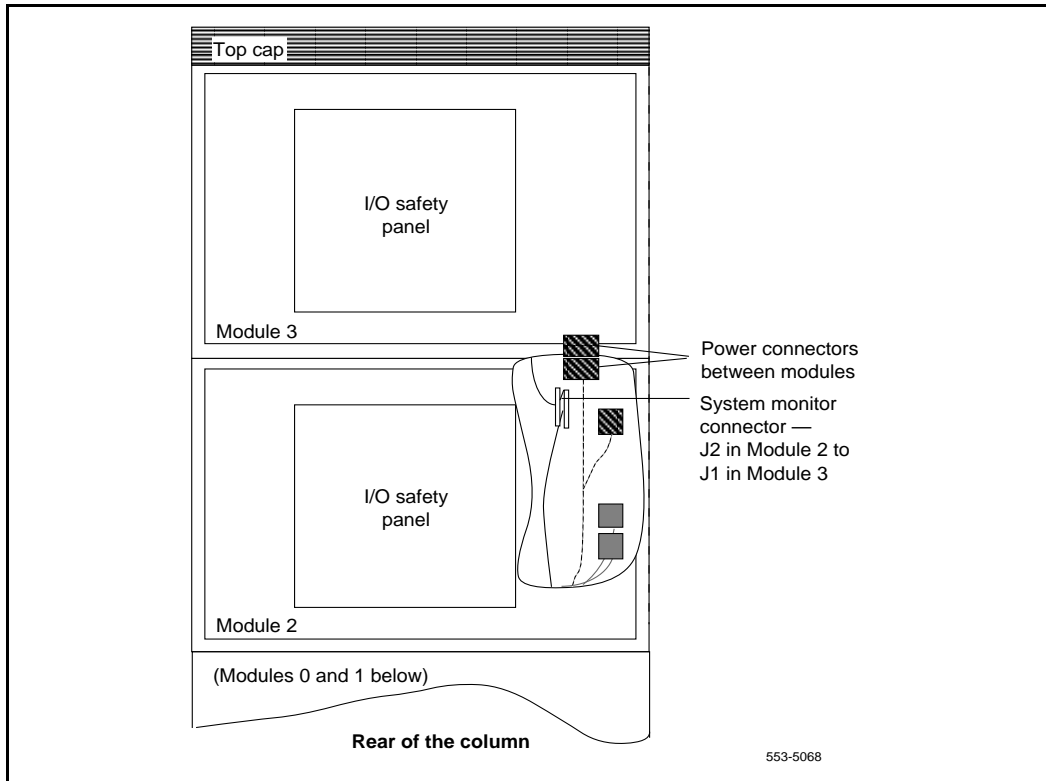

Figure 10
Module mounting bolts



- 2** Connect the module-to-module power and system monitor cables:
 - a.** Connect the power connectors between the modules (see Figure 11 on page 32).
 - b.** Connect the system monitor cable from connector J2 on the third module to J1 on the fourth module.
- 3** Reinstall the I/O safety panel in each module.
- 4** Replace the module covers.

Figure 11
Power and system monitor connections



Positioning and leveling equipment

Columns normally stand on adjustable feet that provide leveling capability and ground isolation. However, casters are available and can be used for two-tier columns. If a third module is added to a column with casters, the casters must be replaced with leveling feet.

Note: If earthquake bracing is required, go to “Installing earthquake bracing” on page 257 to install column and floor bracing and to position and level equipment. When those procedures are complete, return to Step 4 or Step 5 (as applicable) in the initial installation procedure.

Use the following procedure to position and level the equipment:

- 1 Check the equipment room floor plan to position columns.
- 2 Do the following to level a column:
 - a. Remove the front and rear exhaust grills.
 - b. Remove the front and rear air intake grills.
 - c. Position a level across the top module cover on the front of the column.
 - d. Loosen the locking nuts on the feet.
 - e. Adjust the feet on each pedestal up or down to level the column.
 - f. Tighten the locking nuts.
 - g. Perform steps a - e for leveling the rear of the system.

Note: Leave at least 1.27 cm (1/2 in.) between the floor and the bottom of the pedestal for air flow required by the blower unit.

- 3 **For a multiple-column system**, install NT8D49 Spacer Kits between columns:

- a. Remove the front and rear module covers.
- b. Remove the front and rear intake grills, if not already removed.
- c. Remove the trim plates from the module side where the spacer will be attached by removing the four screws securing the trim plates to the module.
- d. Remove the side panel from the module's side where the spacer is being attached by removing the four screws securing the side panel to the module.
- e. Attach gaskets to both sides in the front section of each spacer (see Figure 12 on page 35).
- f. Attach a spacer to one side of each module, except the end column (see Figure 13 on page 35 and Figure 14 on page 36).
 - Position a spacer against the module.
 - Insert one standoff between the spacer and module.
 - Insert the one screw and tighten.
 - Repeat the process for the remaining standoff and screws.



CAUTION

Damage to Equipment

Do not try to adjust the horizontal position of a column by tightening the spacer screws. Tightening the screws with the columns too far apart will warp the spacer.

- g. One at a time, push columns together, level, align, and attach the other side of the spacers.

Figure 12
Positioning spacer gaskets

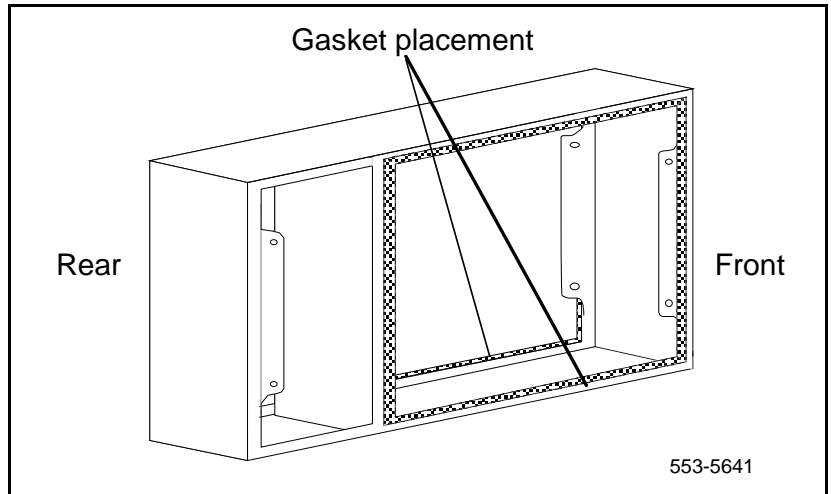

Figure 13
Spacer positioning

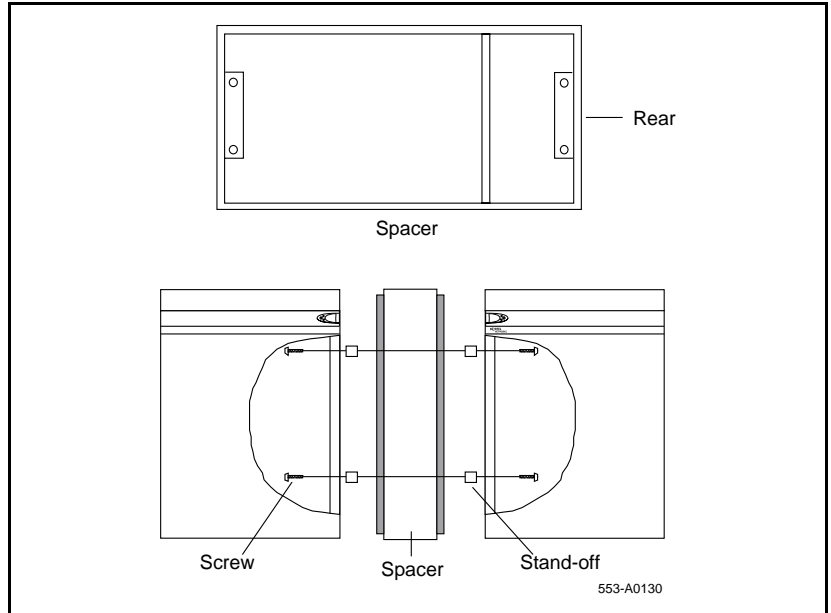
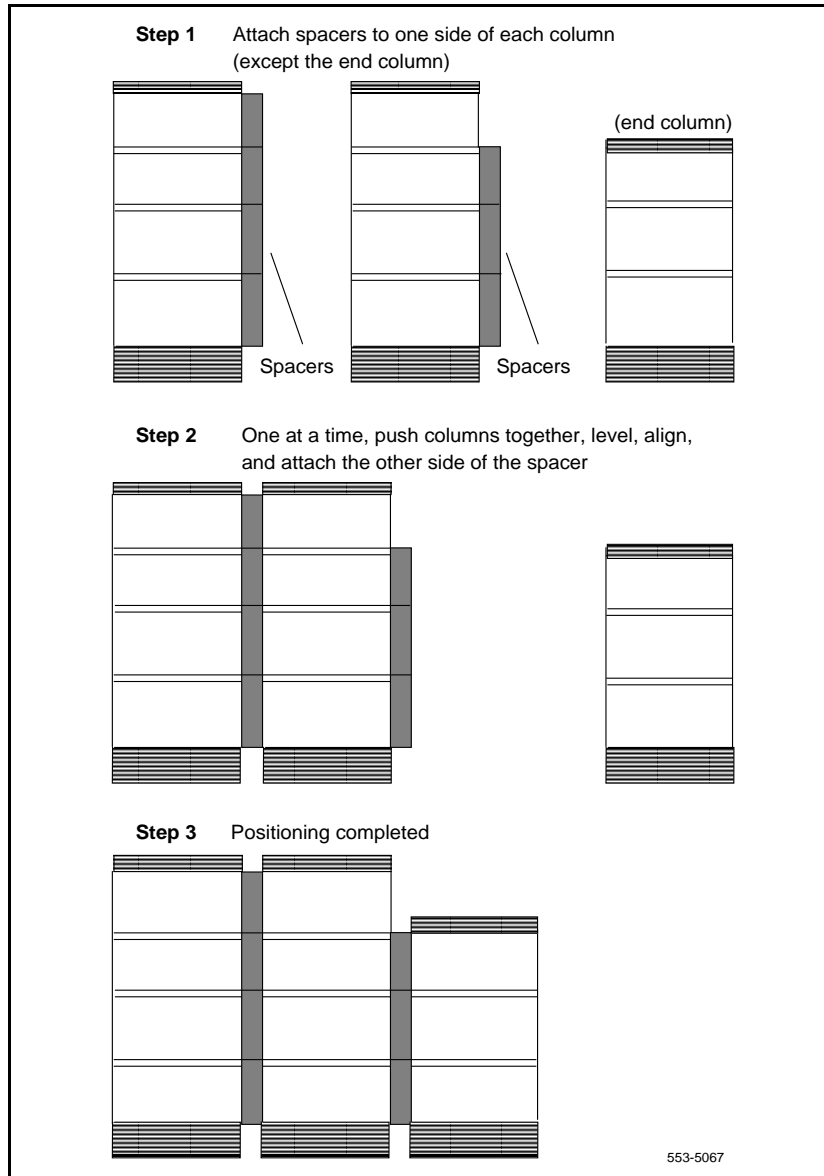

Figure 14
Column positioning with spacers



Installing overhead cable tray kits

Cable trays (also called ladder racks) can hang from a ceiling, or they can be mounted across the tops of the Meridian 1 columns.

If ceiling-hung racks are used, the rear top cap grill on each column must be replaced with a P0699851 Top Cap Cable Egress Panel, which provides cutouts for cable routing. The cable trays and the equipment required to hang them must be provided by the customer and installed according to the manufacturer's instructions.

Nortel Networks offers an NT8D63 Overhead Cable Tray Kit that provides equipment for mounting cable trays on the Meridian 1 columns. The kit includes two support brackets and front and rear exhaust grills with cutouts for cable routing. The cable tray itself must be provided by the customer; it is not included in the kit. Use this procedure to install the NT8D63 kit.

**CAUTION****System Failure**

Column frames must be insulated from contact with building structures such as concrete walls, floors, and ceilings. Whether the cable racks are column-mounted or ceiling-hung, the installation must maintain the integrity of the Meridian 1 grounding architecture.

- 1 Remove air exhaust grills at the front and rear of the top cap. Pull forward on the two clips underneath the front edge of each grill and lift up to remove the grill (see Figure 15 on page 38).
- 2 Mount a support bracket at the front and rear of the module (see Figure 16 on page 38). Using two bolts, secure each support to the threaded holes in the top of the module.

Figure 15
Removing top cap grills

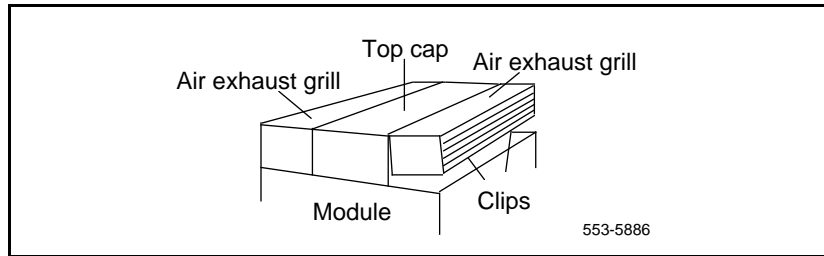

- 3 Install the front and rear air exhaust grills that come with the kit.
- 4 Place the cable rack on top of the support brackets and fasten it to the supports with the J-bolts as shown in Figure 16 on page 38.

Figure 16
Overhead cable tray kit

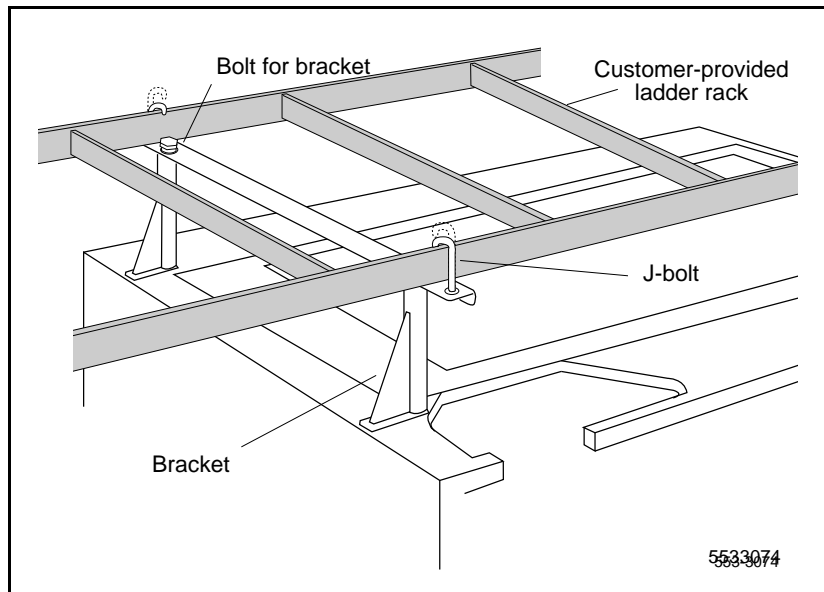

Installing AC power

Content list

The following are the topics in this section:

Reference list	39
AC-powered systems	39
Safety ground/protective earth and logic return wiring	40
Installation procedures	43

Reference list

The following are the references in this section:

- *Installation Planning* (553-3001-120)

AC-powered systems

For AC-powered systems, use this procedure to install safety ground/protective earth and logic return wiring and to install ground and alarm cabling for a UPS.

For AC-powered systems without reserve power, one input receptacle is required per column, within 2.4 m (8 ft) of each pedestal. One IG-L6-30 or L6-30 receptacle is required for each column.

Instead of using the power plug provided, the PDU can be hard-wired to the power source. In this case, #10 AWG conductors routed through 3/4-in. conduit are generally used. The leads connect to the L1, L2, and GND terminations on the field wiring terminal block on the PDU.

Note: Do not use ground fault circuit interrupt (GFCI) devices on Meridian 1 AC power feeds.

Systems that use reserve power plug into the UPS, which in turn plugs into the power source (associated batteries can be located within the UPS or installed externally). Consult the UPS documentation for receptacle requirements.

As a safety precaution, all AC service panels should be located in an area that is easily accessible at all times to allow for emergency shutdown. Additionally, each circuit breaker within a panel should be clearly marked to identify the system component or components it services. An optimal location would be near, or just outside the entry to the room containing the Meridian 1 (or the UPS, if equipped).

Safety ground/protective earth and logic return wiring

A separate safety ground/protective earth connection is required. The safety ground/protective earth wire must be #6 AWG or larger and must connect the pedestal to the single-point ground (SPG) in the service panel. The single-point ground can be an isolated ground (IG) bus or AC equipment ground (ACEG) bus in the service panel or transformer. Figure 17 on page 41, Figure 18 on page 41, and, Figure 19 on page 42 show an ACEG as the single-point ground.

Depending on the distances between columns, the location of the service panel, and the availability of panel SPG connection points, safety ground/protective earth wiring can be daisy-chained or run independently from each column to the service panel. Figure 18 on page 41 and Figure 19 on page 42 show safety ground/protective earth wiring in daisy-chain configurations.

Note: Refer to *Installation Planning* (553-3001-120) for a complete description of approved ground sources and methods. Insulated ground wire must be used for system grounding.

Multiple-column systems use a logic return equalizer (LRE) as the point where the logic return wires from different columns are consolidated before connecting to the single-point ground. The NT6D5304 small LRE (usually used with AC power systems) is available from Nortel Networks.

Figure 17
Single column—ground and logic return distribution

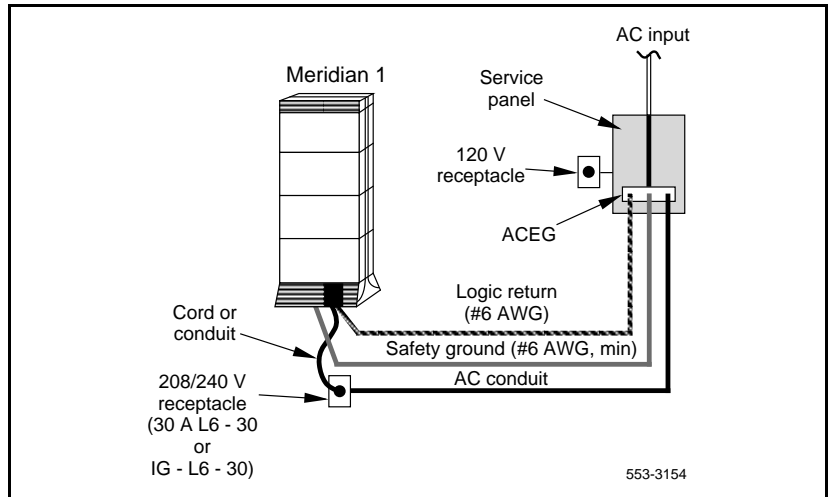

Figure 18
Multiple column—ground and logic return distribution

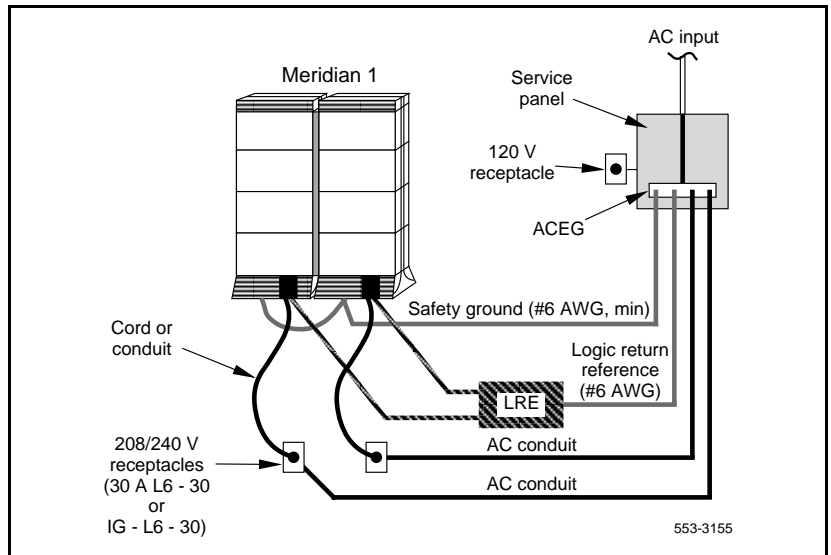
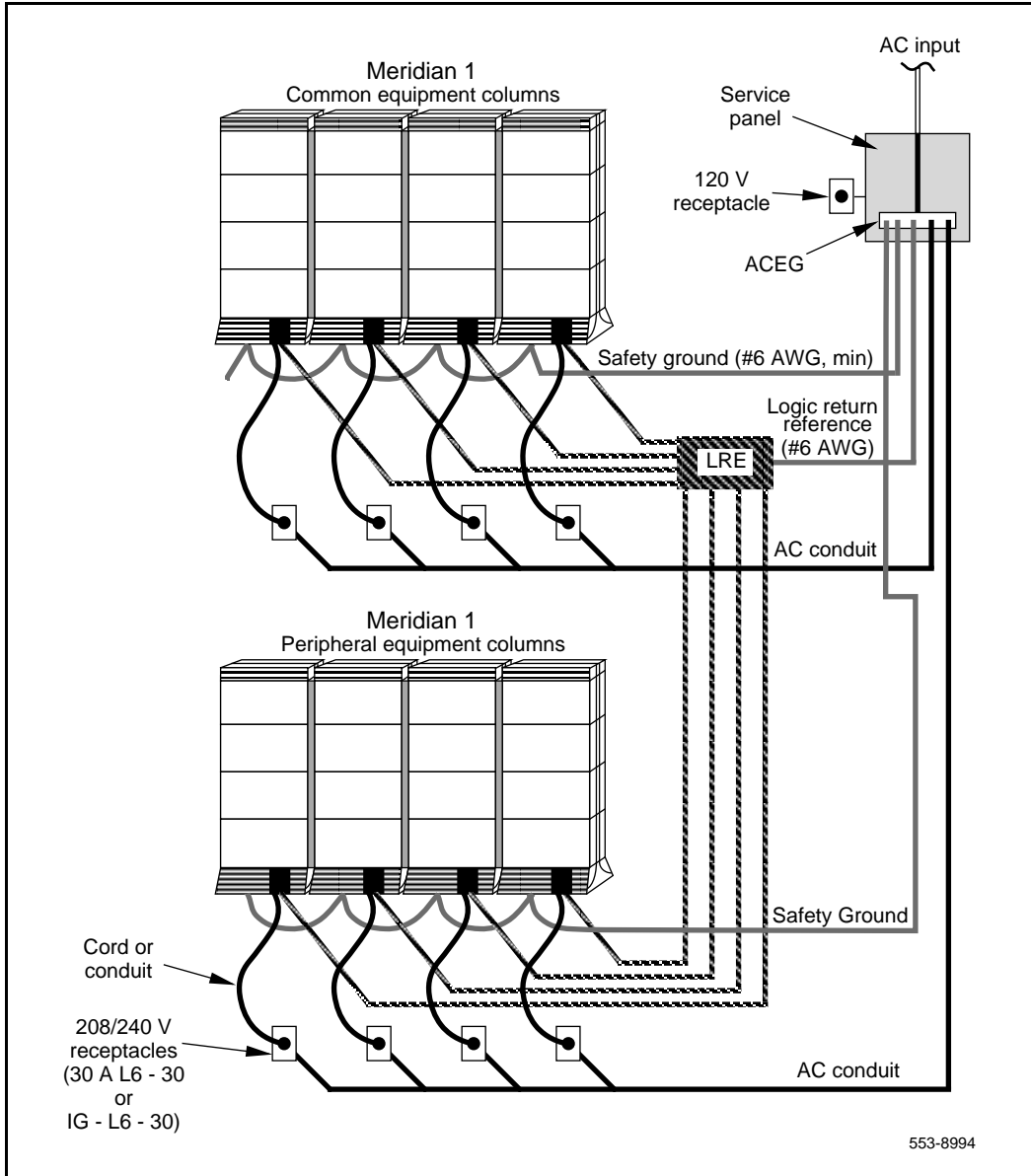

Figure 19
Multiple-column, multiple-row—ground and logic return distribution



Installation procedures

Installing safety ground/protective earth and logic return wiring



CAUTION

System Failure

Failure to follow grounding procedures can result in unsafe or faulty equipment. See *Installation Planning* (553-3001-120) for a complete description of approved ground sources and methods.

- 1 Make sure the power cord is disconnected from the power source.
Note: As a safety precaution, disable the circuit of each column at the service panel.
- 2 Remove the air intake grill.
- 3 Using a volt/ohm meter, measure the resistance between the ground pin on the power plug and a ground lug on the rear of the pedestal (see Figure 20 on page 43).
Note: The resistance should be 0 ohms; if it is greater than 0.5 ohms, check the power cord connections.

Figure 20
PDU ground lug locations

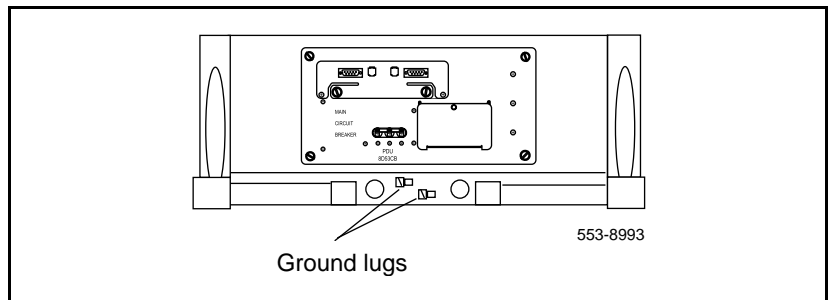

- 4 Connect the safety ground/protective earth wire (insulated ground wire *must* be used for system grounding):
 - a. **For a single-column system**, connect a #6 AWG wire from the ground source in the service panel to a ground lug on the pedestal.

- b. **For a multiple-column system**, connect a #6 AWG wire from the ground source in the service panel to a ground lug on the closest column. Daisy-chain #6 AWG ground wires from one pedestal to the next as illustrated in Figure 21 on page 44, connecting all of the columns together. You can also run a #6 AWG wire from the ground source to each column individually. If the columns are not bolted together, physically separated groups of columns should be grounded individually as shown in Figure 19 on page 42.

Figure 21
AC column ground lug daisy chain connection

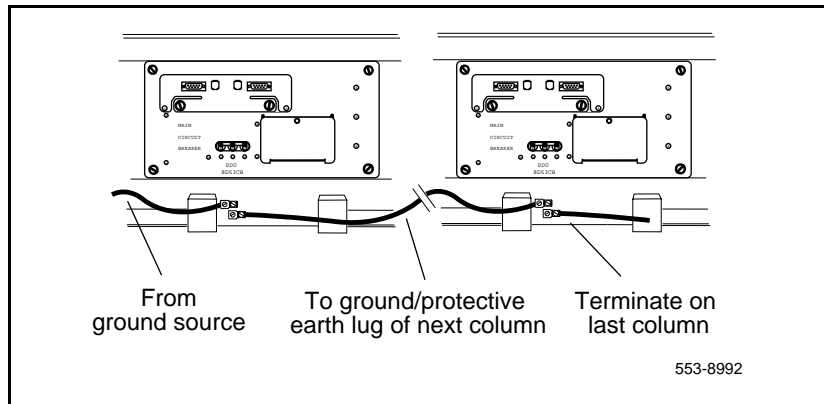

- 5 Place a warning tag (WARNING—TELEPHONE SYSTEM GROUND CONNECTION—DO NOT DISCONNECT) on the connection at the ground source.
- 6 Using a volt/ohm meter, measure the resistance between the ground pin on the power plug and the ground terminal on the power outlet.
- 7 The resistance should be 0 ohms. If the resistance is greater than 0.5 ohms, check the power outlet ground and safety ground/protective earth connections.
- 8 Remove the PDU field wiring access plate.
- 9 Connect the logic return wire.
 - a. Starting at the LRE, connect a #8 AWG wire and route it to the column and up or down the I/O channel area, as appropriate. Then route the wire through the conduit hole in the pedestal to LRTN on the field wiring block (see Figure 22 on page 45).

- 10 Replace the PDU field wiring access plate.

Figure 22
Logic return connection for each column

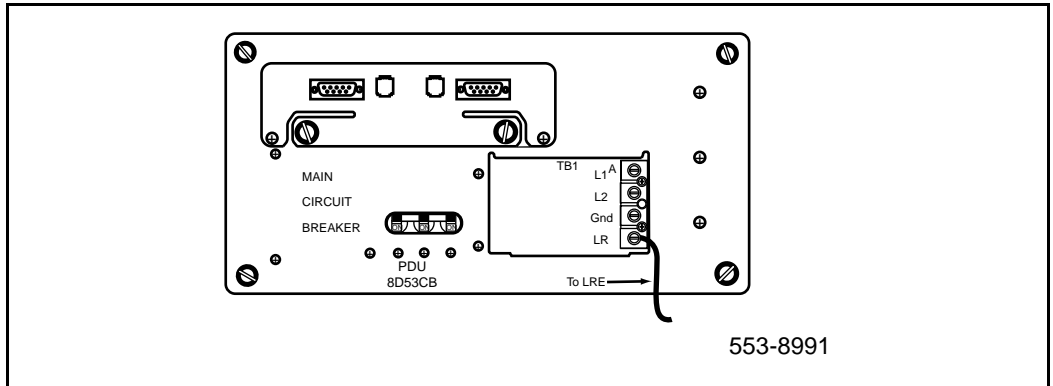

UPS ground cabling

Use the manufacturer's documents to install and cable a UPS. If the UPS does not contain an integral bypass switch, add one externally during initial UPS wiring. Figure 23 on page 46 is a block diagram of a UPS installation and associated wiring.

Note: Because UPS installation can be complex, Nortel Networks recommend that installers attend vendor training programs.



CAUTION

Damage to Equipment

Take care when connecting battery leads to the UPS. A battery reversal can result in severe damage to the UPS.

- 1 Make sure the safety ground/protective earth wire is connected on all Meridian 1 columns.
- 2 Daisy-chain ground cables to each UPS (see Figure 24 on page 47) using #6 AWG wire.

Figure 23
AC reserve power configuration

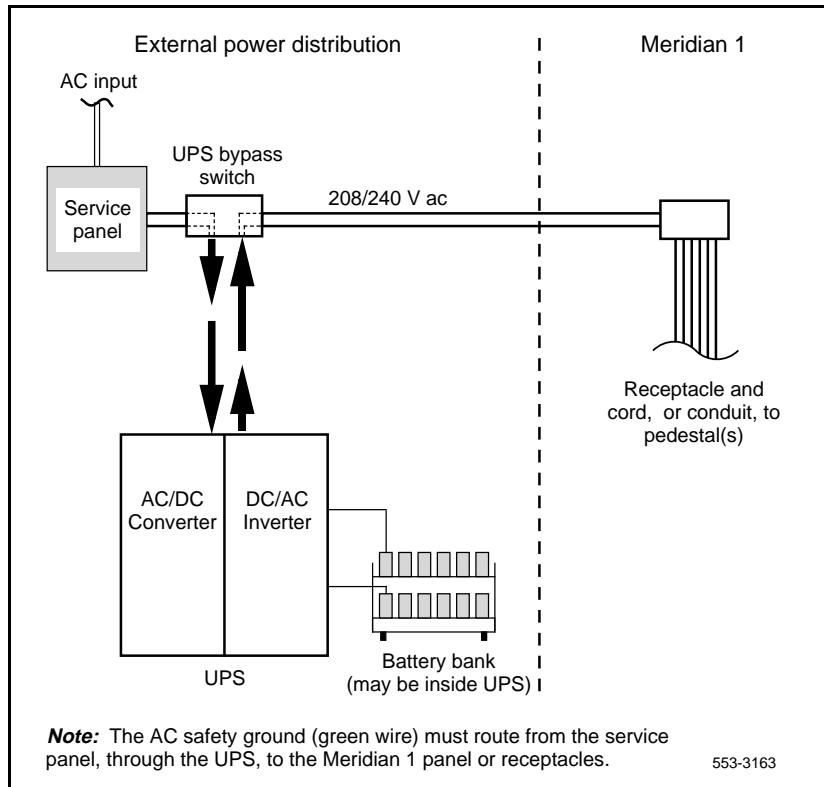

- 3 Daisy-chain ground cables to each bypass switch (if equipped) using #6 AWG wire.
- 4 Run a #6 AWG wire between the ground lug on the rear of the pedestal, the bypass switch, and the UPS to a common frame ground point.
- 5 Run a #6 AWG wire between the common ground point and the ground bus in the service panel.

Figure 24
UPS grounding diagram

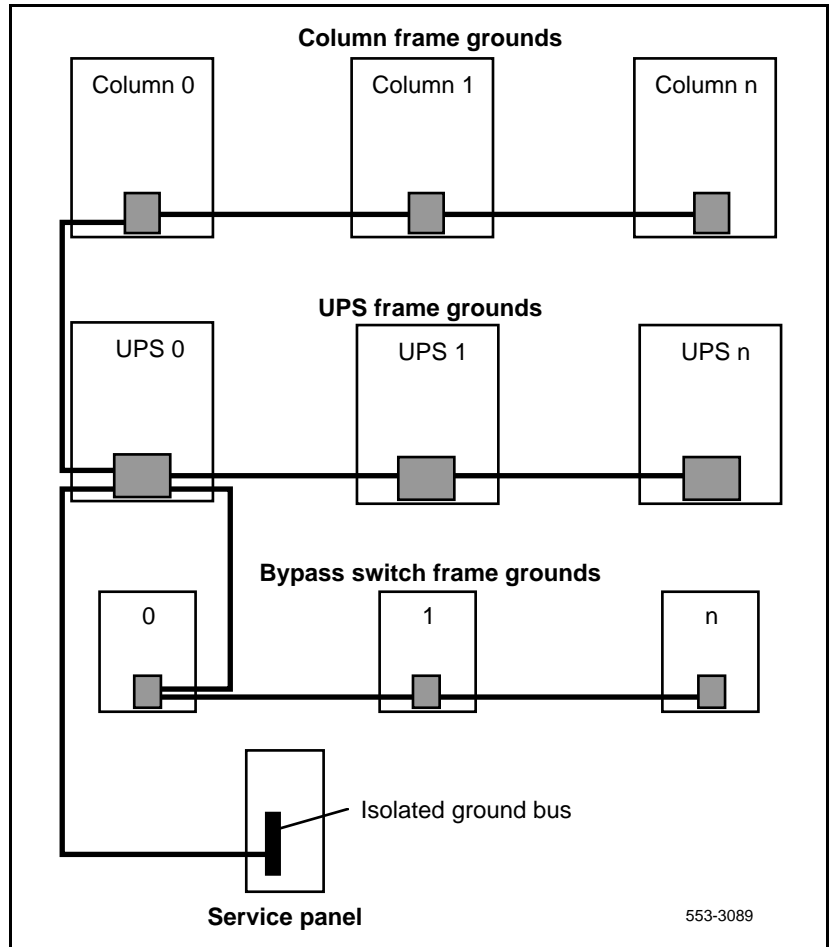

Installing DC power

Content list

The following are the topics in this section:

Reference list	49
DC-powered systems	49
External DC power equipment	50
Safety ground/protective earth and logic return wiring	53
PDU connections	56
Installation procedures	61

Reference list

The following are the references in this section:

- *Installation Planning* (553-3001-120)
- *Power Engineering* (553-3001-152)

DC-powered systems

Use this chapter to install safety ground/protective earth and logic return wiring, configure system monitors, and connect PFTUs for DC-powered systems using an MFA150 or 600/48 power system.

Note: The procedures in this chapter apply to the global power distribution unit (PDU). Throughout this document, the global PDU is referred to as the “NT4N50AA PDU.”

To install reserve power equipment (batteries), follow the instructions provided with the equipment. To comply with safety requirements, consult the following articles before working with any battery systems:

- Read the “Material Safety Data Sheet” that must be posted to meet OSHA requirements. This article outlines appropriate reserve battery handling procedures.
- Refer to National Electric Code 645-10. This article outlines requirements that call for the installation of AC- and DC-power kill switches to battery systems in certain environments.

As a safety precaution, all AC service panels should be located in an area that is easily accessible at all times to allow for emergency shutdown. Additionally, each circuit breaker within a panel should be clearly marked to identify the system component or components it services. An optimal location would be near, or just outside the entry to the room containing the DC power system for Meridian 1.

See Appendix A: “NT0R72, NT6D82, QBL12, QBL15, QCA13” on page 295 in this document to perform one of the following tasks:

- connect an NT6D82 Power System
- install and connect a QBL12 Power Distribution Box
- install and connect a power plant consisting of a
 - QBL15 Power Distribution Box
 - NT6D52 or NT0R72 Switched Mode Rectifier (NT0R72 replaces NT6D52)
- connect a QCA13 Power System

External DC power equipment

The MFA150 Modular Power System and the System 600 Power Plant are considered “external” power equipment because they are not housed in Meridian 1 columns.

DC-powered systems generally require one input receptacle per rectifier, within 1.8 m (6 ft) of each rectifier. The commercial power receptacles required are determined by the number and type of rectifiers used.

MFA150 Modular Power System

The MFA150 is a DC power system for Options 51C, 61C, and 81C. It replaces the rectifier/rack assembly consisting of the NT6D52 or NT0R71 Rectifier and QBL15 Power Distribution Unit.

The MFA150 is a modular, front access power system with a positive ground and –48 V dc output capacity of 150 amps, provided in 25-amp increments using plug-in rectifier modules. The MFA150 is suitable for any system with power requirements of less than 150 amps. One MFA150 is required per DC system (configured with one to six NT5C06 rectifiers, as required by system power consumption), installed in one or two MPS75 shelves.

The ordering codes for the complete power plant are NT5C90EF and NT5C90EG. Each of these configurations is a complete power bay with an NT6C14GB Control and Distribution Panel mounted on an NT6C40DC Seismic Rack:

- NT5C90EF is a single MPS75 shelf, with a capacity of 75 amps.
- NT5C90EG is a dual-shelf configuration, with a capacity of 150 amps.

The MFA150 power system requires one 50-amp power feed per shelf.

System 600/48 Power Plant

The System 600/48 Power Plant is a positive ground, –48 V dc, 600-A power plant. It can be used with all Meridian 1 DC-powered systems, but is optimized for larger system configurations such as system Option 81C. Other switchroom equipment that requires –48 V dc power may also be powered from the System 600 Power Plant, as long as there are sufficient output circuit breakers or auxiliary fuses, the total load does not exceed 600 A, and a consistent, single-point ground topology is maintained for all associated equipment.

The System 600 Power Plant consists of either the NT6C32AD main bay (for loads requiring up to 300 A) or the NT6C32AD main bay and the NT6C32AE supplemental bay (for loads up to 600 A), a front access common equipment panel, one front access controller, one front access circuit breaker panel, and two rectifier shelves that can contain up to six NT5C07AC rectifiers. Included with the supplemental bay are all DC cables and signal wires to connect the supplemental bay to the main bay.

The System 600/48 Power Plant utilizes up to twelve 50-A switch mode rectifiers (NT5CO7AC) as building blocks connected in parallel to reach the maximum capacity of 600 A. This maximum capacity may be attained without power interruption to the load.

The rectifiers operate on single-phase 50 or 60 hertz AC service from either 208 V or 240 V nominal input. The power system may operate with or without -48 V dc batteries for reserve power. If batteries are connected, the rectifiers can operate in either the float or equalize mode.

The System 600/48 Power Plant is designed with access from the front. All operational controls are accessible from the front of the unit. It is designed for seismic environments to Zone 4 (Bellcore) free standing configurations, with no external bracing required.

The System 600/48 Power Plant has a variety of monitoring and alarm features, such as high and low voltage alarms, fuse and breaker alarms, rectifier failure alarms, and low voltage disconnect. An interface to the NT8D22 System Monitor provides a subset of these alarms.

NT6D53 Junction Box

If a rectifier is positioned at a distance from the Meridian 1, the NT6D53 Junction Box can provide an interim connection between the rectifier and the field wiring terminal block in the pedestal. One junction box supports one column. The junction box can be used with the NT4N50AA PDU, but it is not required.

The junction box is equipped with a 3-m (10-ft) flexible conduit that contains all the wiring needed to connect the rectifier to the pedestal. (Make sure the junction box is installed close enough to the pedestal for the conduit to reach the terminal block in the pedestal.)

On the input side, the junction box has allowance for up to four #4 AWG pairs and one logic return, and up to two 1-1/4 in. conduit fittings (one fitting is supplied). On the output side, the junction box is prewired with four #10 AWG pairs (one pair per module) and a logic return. This wiring is routed in a 3-m (10-ft) length of 3/4-in. conduit that connects to the pedestal.

The junction box connects to the pedestal as follows:

- For distances of up to 30 m (100 ft), there are
 - four split feeds per column with nine #10 AWG conductors in a single 3/4-in. conduit
 - two 30-amp feeds from the distribution point to the junction box with five #4 AWG conductors in a single 1-1/4 in. conduit
- For distances of up to 60 m (200 ft), there are
 - four split feeds per column with nine #10 AWG conductors in a single 3/4-in. conduit
 - two 30-amp feeds from the distribution point to the junction box, with nine #4 AWG conductors in two 1-1/4 in. conduits

Safety ground/protective earth and logic return wiring

The single-point ground (SPG) required by the system can be an isolated ground (IG) bus or AC equipment ground (ACEG) bus in the service panel or transformer. The system must be connected to safety ground/protective earth in accordance with NEC requirements. For international use, the system must be connected to safety ground/protective earth in accordance with Paragraph 2.5 of EN60950/IEC950.

Note: Refer to *Installation Planning* (553-3001-120) and *Power Engineering* (553-3001-152) for a complete description of approved ground sources and methods. Insulated ground wire must be used for system grounding.

Depending on the distances between columns, the location of the service panel, and the availability of panel SPG connection points, safety ground/protective earth wiring can be daisy-chained or run independently from each Meridian 1 column to the SPG or alternately to a logic return equalizer (LRE). Figure 26 on page 55 and Figure 26 on page 55 show safety ground/protective earth wiring in daisy-chain configurations. For the MFA150, safety ground is daisy-chained between columns and then run directly to the ACEG in the service panel. For the System 600/48 Power Plant, safety ground is daisy-chained between columns and then run to the ACEG. The System 600/48 safety ground is connected to the AC panel through the AC input conduit.

Multiple-column systems use an LRE as the point where the logic return wires from different columns are consolidated before connecting to the single-point ground. The LRE used with the MFA150 and System 600/48 is a copper bus bar mounted in the control/distribution panel of the power system.

Figure 25
Ground and logic return distribution—MFA150 Modular Power System

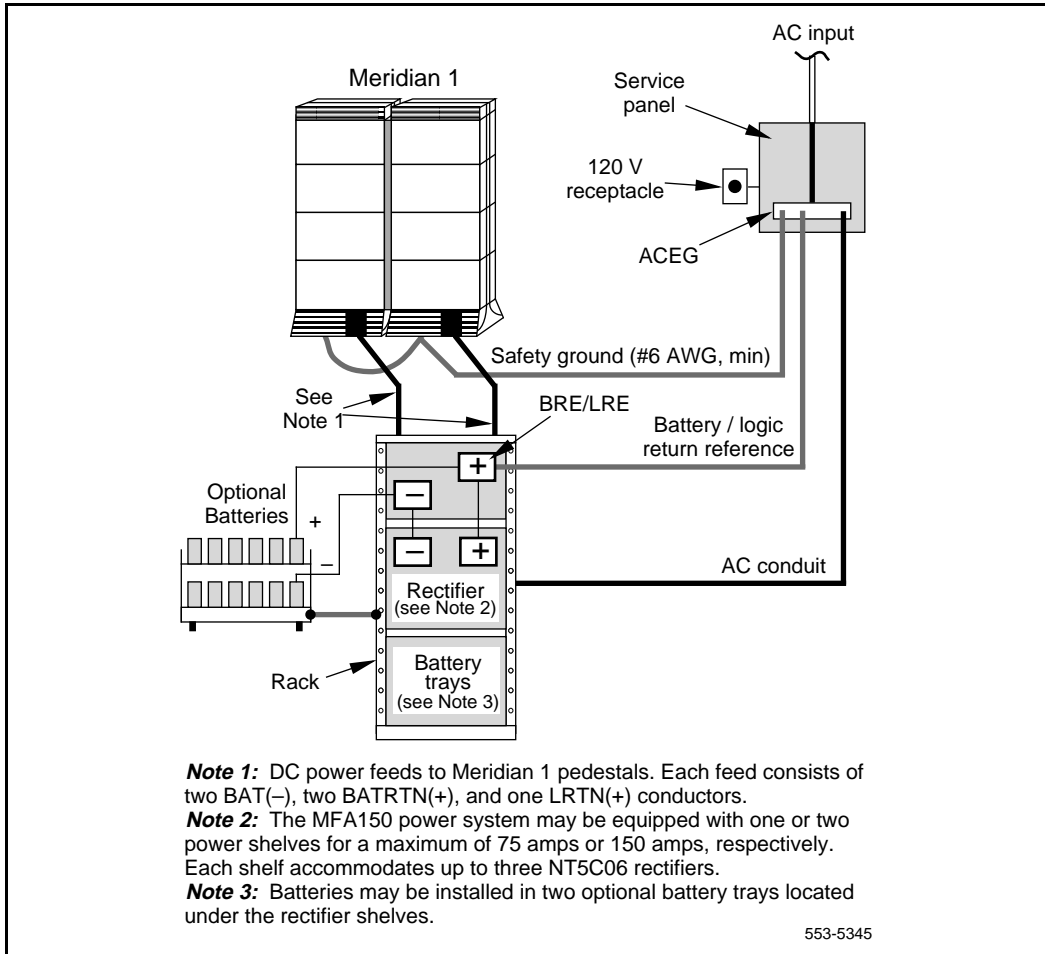
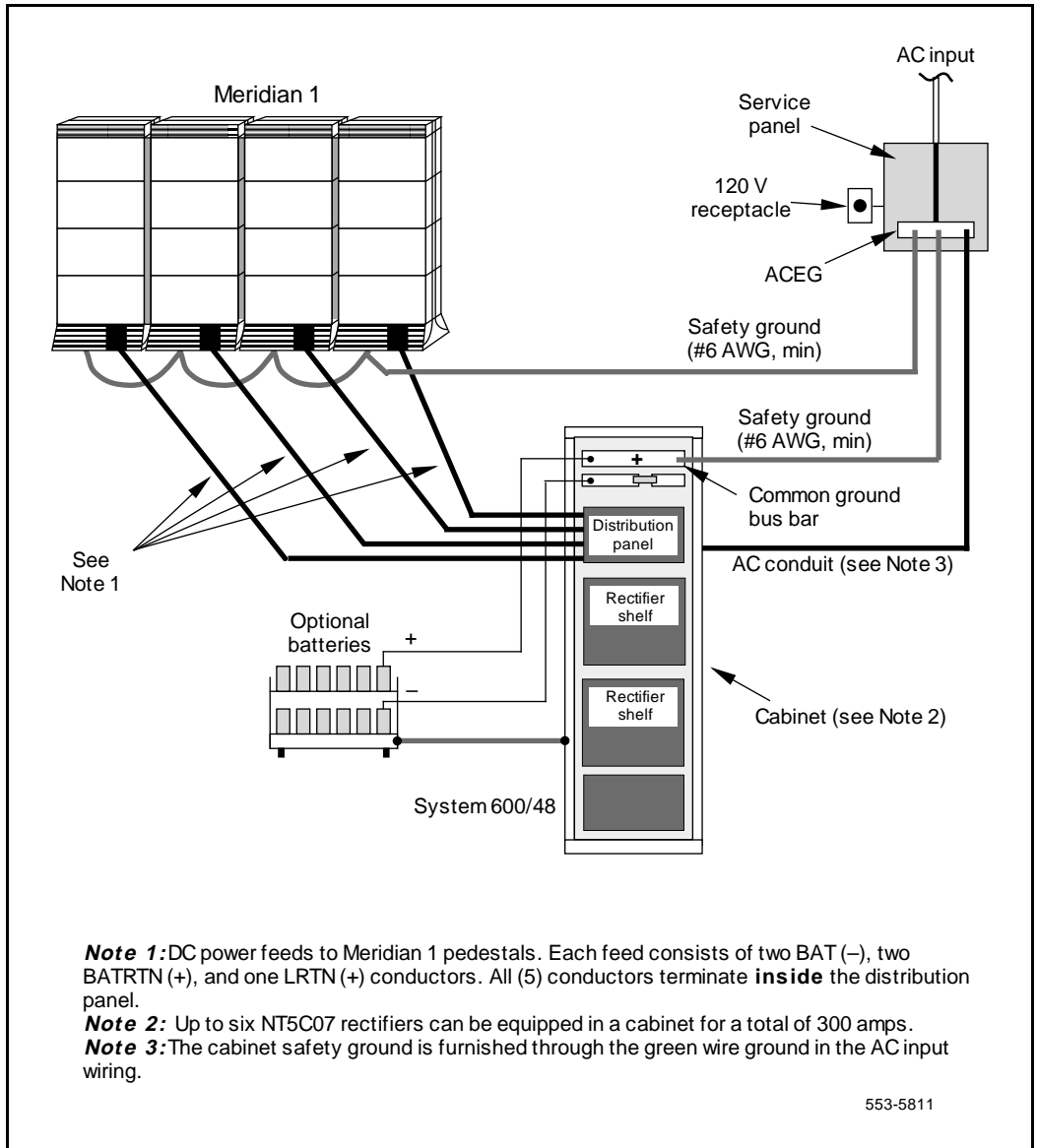

Figure 26
Ground and logic return distribution—System 600/48 Power Plant



PDU connections

A readily accessible disconnect device for input power is required.



CAUTION

Damage to Equipment

DC power for the NT7D09 pedestal must be provided with circuit protection of 30 amps for the -BAT 0/1 and -BAT 2/3 feeds (see Figure 26 on page 55).

Circuit breakers must be located next to each other and labeled to show that both must be shut off to remove all power to the system.

Figure 27
PDU circuit protection

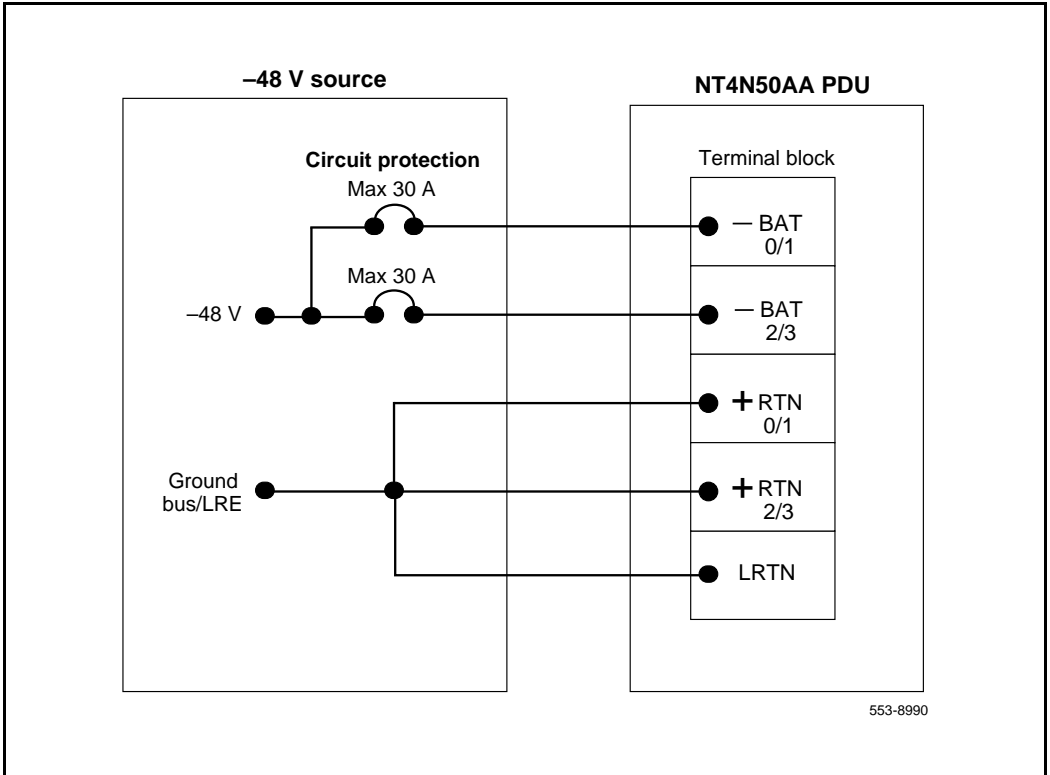

A maximum loop drop of two volts is allowed between the pedestal, or junction box, and the external power equipment. See Table 2 on page 58 for allowable wire sizes. See *Power Engineering* (553-3001-152) for detailed information on calculating wire size.

Table 2
Wire gauge requirements with two 30-amp feeds (five wires)

Length	#8 AWG	#6 AWG	Single #4 AWG	Double #4 AWG
0–3 m (10 ft)	Yes	Yes	Yes	Yes
3–6 m (20 ft)	Yes	Yes	Yes	Yes
6–9 m (30 ft)	Yes	Yes	Yes	Yes
9–12 m (40 ft)	Yes	Yes	Yes	Yes
12–15 m (50 ft)	Yes	Yes	Yes	Yes
15–18 m (60 ft)	No	Yes	Yes	Yes
18–21 m (70 ft)	No	Yes	Yes	Yes
21–24 m (80 ft)	No	Yes	Yes	Yes
24–27 m (90 ft)	No	No	Yes	Yes
27–30 m (100 ft)	No	No	Yes	Yes
30–60 m (200 ft)	No	No	No	Yes
over 60 m (200 ft)	No	No	No	No

Note 1: Two 30-amp feeds are typically adequate for a column with four modules (five wires total—two 30-amp feed pairs plus logic return).

Note 2: If dual conduit is used, the wires must be run in battery/battery return pairs, with one pair in one conduit and the other pair, plus logic return, in the other conduit.

Legend: Yes= Wire size is adequate for the distance.
 No= Wire size has too high a voltage drop and is inadequate for the distance.

The following equipment is located in the rear of each pedestal (see Figure 28 on page 59) in Meridian 1 columns:

- The PDU distributes power to the entire column.
- The field wiring terminal provides the connection point for wiring brought into the pedestal.
- A circuit breaker is provided for each module in the column and for the blower unit

Note: All column circuit breakers will trip if a column thermal overload is detected or a DC-power low-voltage condition is sensed.

- The system monitor checks the column temperature, cooling system status, and system voltage status, and controls alarms and line transfer states accordingly.

Figure 28
DC-power equipment in the rear of the pedestal—NT4N50AA PDU

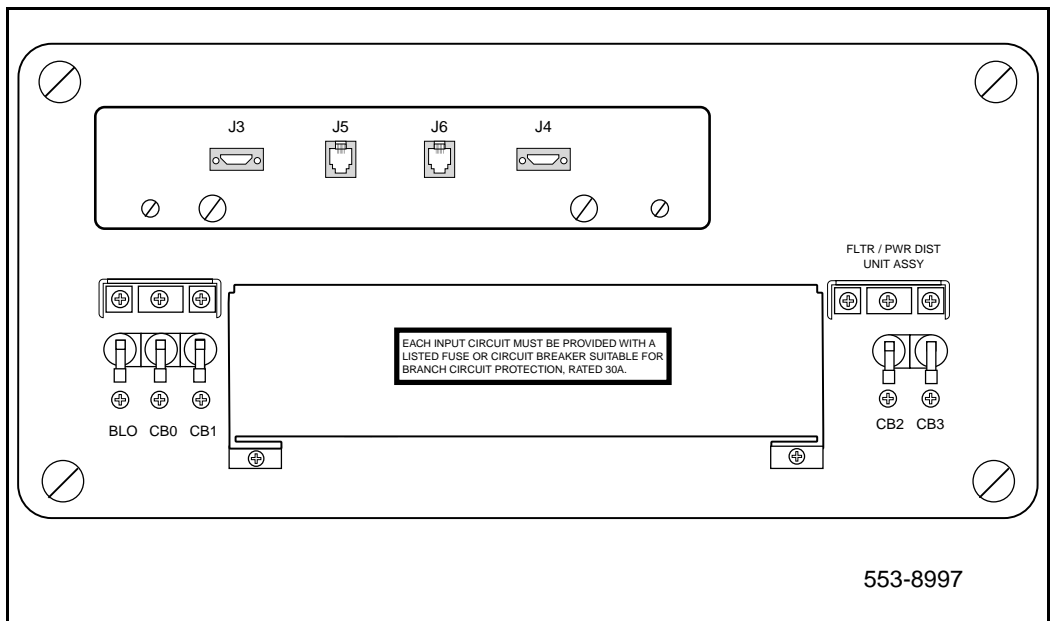

With the NT4N50AA PDU, the safety ground/protective earth wires and all wiring to the terminal block in the PDU must be neatly routed within the cable-tie saddles and under the cable restraint bar at the base of the pedestal (see Figure 29 on page 60). This ensures that there is room to install the PDU cover, safety cover, and rear grill.

Conduit is not required with the NT4N50AA PDU. However, 1-1/4 or 3/4 in. conduit can be used if local codes or individual installations require it. Conduit can be routed down through the column from overhead racks or up through the floor. Conduit clamps and the hardware to fasten the conduit are provided in the pedestal. If the NT7D0902 Rear Mount Conduit Kit is used, conduit can enter from the rear of the column (above the floor).

Figure 29
Cable routing in the rear of the pedestal—NT4N50AA PDU

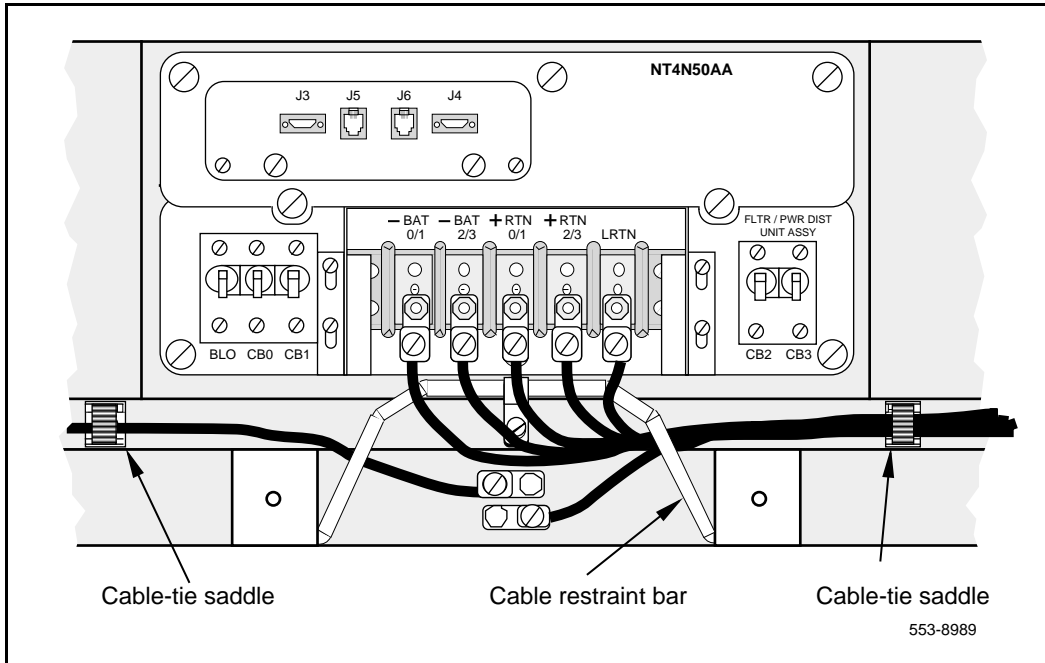

Installation procedures

Installing safety ground/protective earth wiring

**CAUTION****System Failure**

Failure to follow grounding procedures can result in unsafe or faulty equipment. See *Installation Planning* (553-3001-120) for a complete description of approved ground sources and methods.

- 1 Remove the associated 30-amp fuse or set circuit breakers to the OFF position in the power plant, to disconnect each pedestal from the power source.
- 2 Remove the air intake grill from the rear of the pedestal.
- 3 At the rear of the pedestal, use a Phillips screwdriver to remove the metal cover over the terminal block to access the safety ground/protective earth lugs. Leave the cover off until all pedestal connections are made.
- 4 Connect the safety ground/protective earth wire:
 - Note:** Use only insulated ground wire for system grounding.
 - a. **For a single-column system**, connect a #6 AWG wire from the ground source in the service panel to a ground lug on the pedestal.
 - b. **For a multiple-column system**, connect a #6 AWG wire from the ground source in the service panel to a ground lug on the closest column. Daisy-chain #6 AWG ground wires from one pedestal to the next as illustrated in Figure 30 on page 62, connecting all of the columns together (or run a #6 AWG wire from the ground source to each column individually)

Note: The safety ground/protective earth wire must be routed within the cable-tie saddles and under the cable restraint bar at the base of the pedestal.
- 5 Place a warning tag (WARNING—TELEPHONE SYSTEM GROUND CONNECTION—DO NOT DISCONNECT) on the connection at the ground source.

Figure 30
DC Column ground lug daisy chain connection

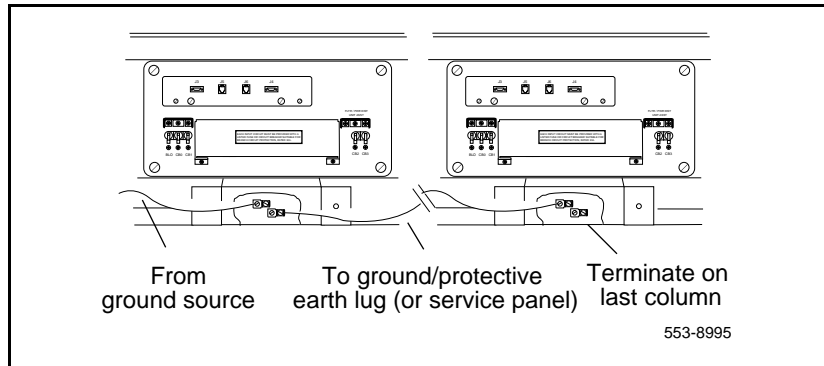

Preparing the NT4N50AA PDU

When a system is shipped, a set of screws secures the leveling bracket at the rear of the NT4N50AA PDU to protect it from vibration damage during transit. The shipping screws should be removed during initial installation.

- 6 For access to the rear of the PDU, temporarily remove the blower unit in the front of the pedestal:
 - a. Turn the screws on the front of the blower unit counterclockwise.
 - b. Grasp the lip at the top edge of the blower unit. Slide the unit out of the glides and onto the bottom ledge of the pedestal. Lift the unit out of the pedestal. (Keep the blower unit in an upright position.)
- 7 Remove the two shipping screws holding the PDU to the vertical shield in the pedestal.
- 8 Reinstall the blower unit:
 - a. Set the blower unit on the bottom ledge of the pedestal.
 - b. Tilt the back of the blower unit up slightly so it will slide into the pedestal glides (you may need to lift the unit). Gently push the unit into position.
 - c. Tighten the screws on the front of the blower unit.

Connecting power from the power plant to the NT4N50AA PDU

Note 1: On columns which have only two modules, run five wires to facilitate future expansion to a four module column.

Note 2: If only two modules are used in the column, set the CB2 and CB3 circuit breakers to off.

- 9 Ensure that power to the power plant is removed from the service panel.
- 10 Remove the air intake grill from the rear of the column pedestal being wired:
 - Remove the two screws securing the air intake grill to the pedestal.
- 11 Use a Phillips screwdriver to remove the PDU safety cover.
- 12 Remove the top cover from the power plant:
 - a. Remove the six screws from the top of the power plant.
 - b. Release the captive screw on the front control panel.
 - c. Lay the control panel down and remove the top cover.
- 13 Route the wires between the power plant and the pedestal of the column being wired.
- 14 Using a junction box:
 - a. If a junction box is used, insert the conduit from the junction box into one of the conduit access holes in the pedestal.
 - b. Route the wires within the cable-tie saddles and under the cable restraint bar at the base of the pedestal.
 - c. Connect the wires to the matching connections on the terminal block on the junction box:
 - Connect the red wires to BAT 0,1 and BAT 2, 3
 - Connect the black wires to BATRTN 0,1 and BATRTN 2, 3
 - Connect the orange or white wire to LRTN.
- 15 Without a junction box:
 - a. Route two red wires between the power plant and the pedestal of the column being wired.

Figure 31
PDU to MFA150 connections

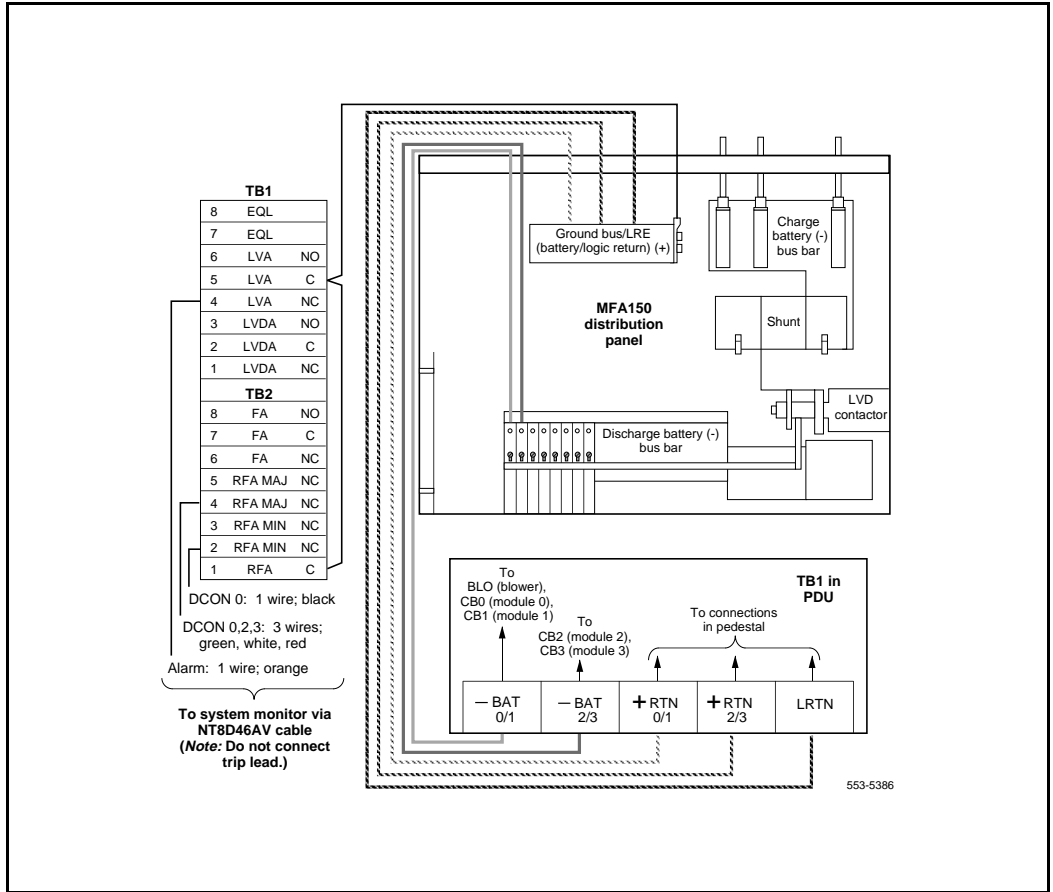
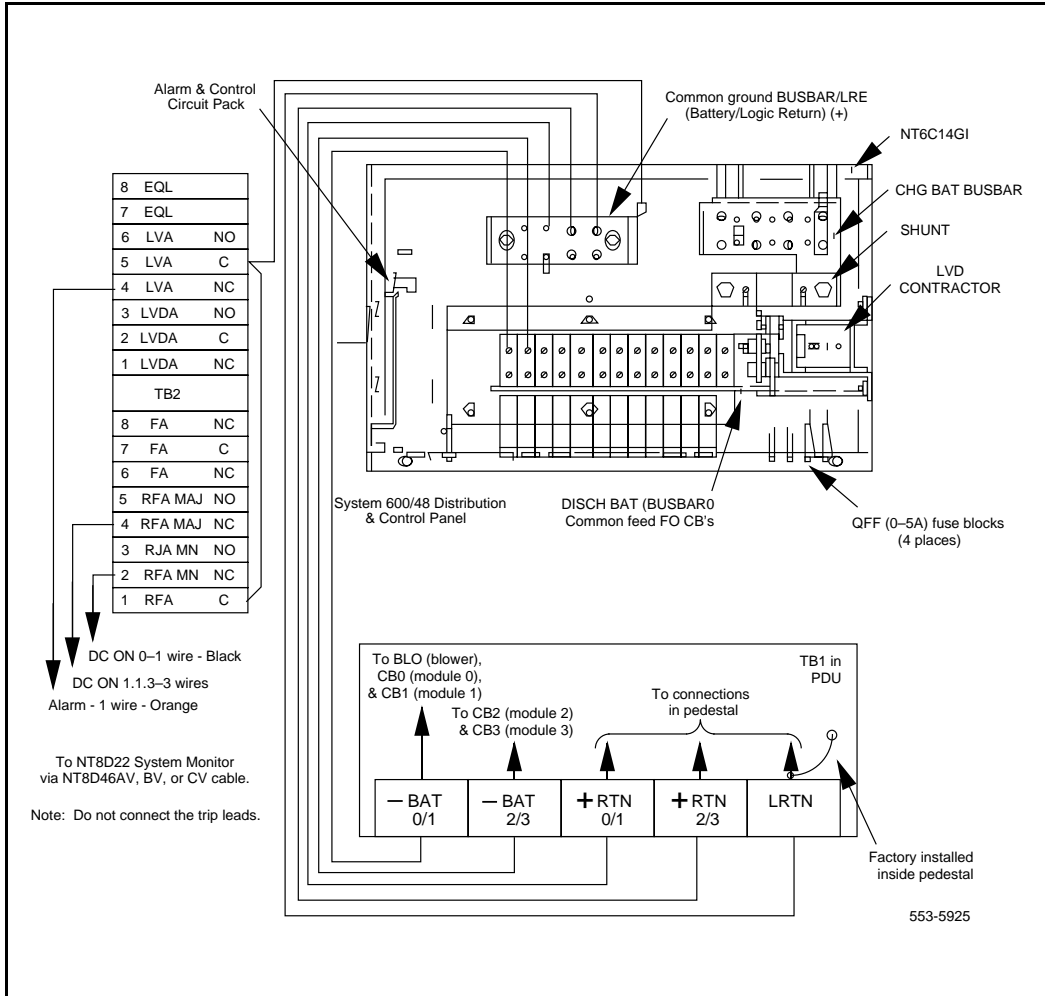

Figure 32
PDU to System 600/48 Power Plant connections



Connecting UK power to the NT4N50AA PDU

To connect the external power system to the pedestal, use the following procedure for each column (this procedure gives the connections for a four-module column).

Note: All wiring to the PDU must be routed within the cable-tie saddles and under the cable restraint bar at the base of the pedestal.

- 1 Open the front door of the 8B/2R or 8B/4R master power cabinet
- 2 If a junction box is used, insert the conduit from the junction box into one of the conduit access holes in the pedestal.

Connect the wires from the junction box to the matching connections on the terminal block on the PDU:

- a. Connect the red wires BAT0 through BAT3.
- b. Connect the black wires RTN0 through RTN3.
- c. Connect the remaining LRTN wire (orange or white wire).

Note: If a junction box is used, the connections described in Steps 2 through 4 apply to the junction box rather than the pedestal.

- 3 Connect the red BAT (–48V) wires:
 - a. At the 8B/2R or 8B/4R master power cabinet, connect wires to the first two terminals on the –ve distribution rail (see Figure 31 on page 65).
 - b. At the PDU, connect the wires to the terminal block (one wire feeds two modules):
 - for modules 0 and 1 connect to -BAT 0/1
 - for modules 2 and 3 connect to -BAT 2/3
- 4 Connect the black BATRTN (+48V) wires:
 - a. At the 8B/2R or 8B/4R master power cabinet, connect wires to the +ve bus
 - b. At the PDU, connect the wires to the terminal block (one wire feeds two modules):
 - for modules 0 and 1 connect to +RTN 0/1
 - for modules 2 and 3 connect to +RTN 2/3

- 5 Connect an orange #8 AWG (10 sq mm) LRTN wire from the logic return equalizer (LRE) in the rear of the master power cabinet to LRTN on terminal block TB1 in the pedestal. (See Figure 31 on page 65.)
- 6 Reinstall the metal safety cover over the terminal block:
 - a. Lower the front panel over the mounting screws on the PDU.
 - b. Tighten the screws holding the cover.
- 7 Close the covers on the 8B/2R or 8B/4R master power cabinet.

System monitor connections

When connecting to an 8B/2R or 8B/4R master power cabinet, one NT8D46AT cable is required to extend the alarm terminal to the master system monitor in the pedestal. See Figure 31 on page 65.

The orange colored wire on NT8D46AT marked “ALARM” extends from any of three alarm terminals on the top of the power cabinet to connector marked J4 in the system monitor. The remaining “Trip” and “DC ON” wires on the NT8D46AT cable are not used and should be snipped before installing the cable.

Figure 33
UEM to 8B/2R or 8B/4R master power cabinet 2R or
8B/4R master power cabinet connections

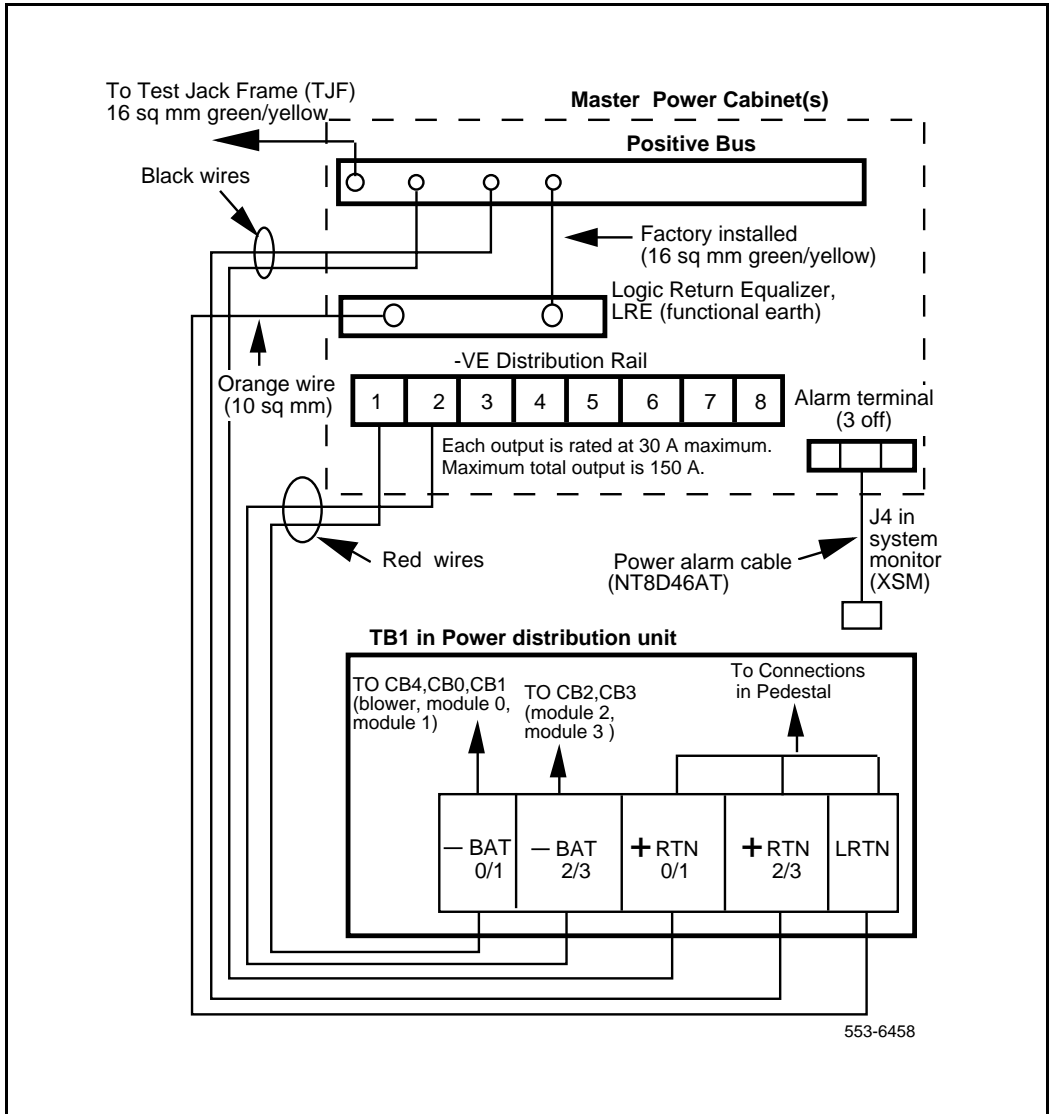

Planning and designating the Modular Distribution Frame (MDF)

Content list

The following are the topics in this section:

Meridian 1 terminations	71
BIX installation and designation	73
Backplane cable expansion	78
Krone cross connect system (UK)	78

Meridian 1 terminations

All Meridian 1 terminations are cross-connected on frame-mounted or wall-mounted BIX Modules and connecting blocks. The layout of the blocks can vary to meet the requirements of the site.



DANGER OF ELECTRIC SHOCK

Tip, ring, A, B, E, M, ESC, and ESCG connections can be considered to be Telecommunications Network Voltages (TNV).

Table 3 on page 72 lists part numbers for BIX designation labels.

Table 3
Order codes for BIX designation strips

Label	Part number
NT8D11 CE/PE Module (basic label)	P0711373
NT8D37 IPE Module (basic label)	P0711372
NT8D37 IPE Module (fully expanded label)	P0711371
NT8D14 Universal Trunk Card (RAN)	P0711376
NT8D14 Universal Trunk Card (paging)	P0711378
NT8D14 Universal Trunk Card (CO/FX/WATS and all other modes)	P0711380
NT8D15 E&M Trunk Card (2-wire, type 1)	P0711379
NT8D15 E&M Trunk Card (2-wire, paging)	P0711377
NT8D15 E&M Trunk Card (4-wire, type 1)	P0711374
NT8D15 E&M Trunk Card (4-wire, type 2)	P0711375
A0355200 PFTU:Dees Model 154A	P0711382
Gordon-Kapes Model BP-2-48	P0711383

BIX installation and designation

- 1 Install BIX cross-connect blocks according to the installation procedure described in *BIX Installation and Servicing* (631-4511-200).
 - The BIX Module includes one QMBIX10A mount, ten QCBIX1A connectors, and five QSBIX20A designation strips. A QMBIX12E mount, which holds 12 QCBIX1A connectors, is also available.
 - Figure 34 on page 74 shows a wall-mounted BIX Module.
 - Figure 35 on page 75 shows the recommended BIX Module layout for NT8D37 IPE Modules.
- 2 Attach the adhesive designation labels for lines to the BIX designation strips. Figure 36 on page 76 shows samples of the basic BIX designation labels for NT8D11 CE/PE and NT8D37 IPE Modules.
- 3 Attach the labels for trunks on top of the basic labels according to the assignments shown on the work order. The transparent window on the trunk labels allows the card number on the basic labels to be seen.
 - Figure 37 on page 76 shows samples of the overlay BIX designation labels for all NT8D14 Universal Trunk modes.
 - Figure 38 on page 77 shows samples of the overlay BIX designation labels for all NT8D15 E&M Trunk modes.
- 4 Attach the labels for the P1, P2 (from the PFTU), and P3 (alarm) cable connections. Figure 39 on page 77 shows samples of the BIX designation labels for the PFTU.
- 5 Attach the labels for incoming trunks, telephones, and riser cables according to the work order.

Figure 34
BIX Module

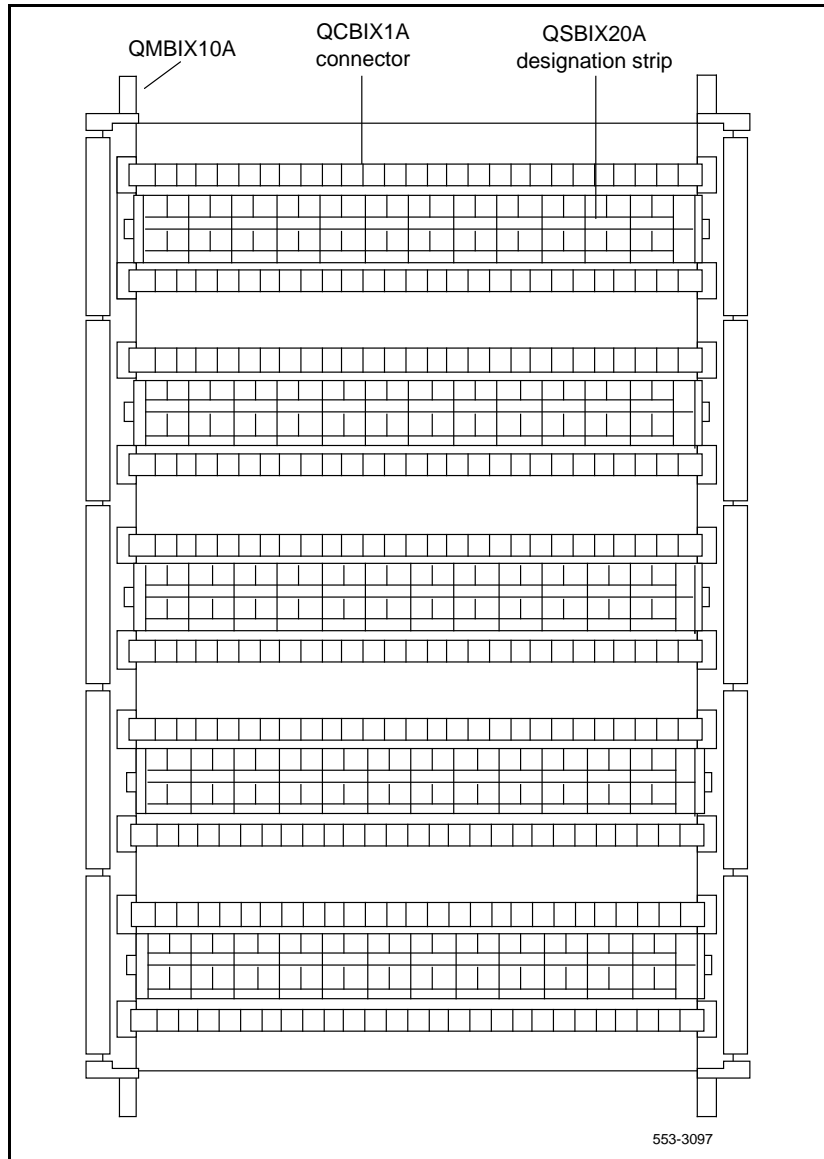

Figure 35
Recommended BIX layout for NT8D37 IPE Modules

Cable terminations for one NT8D37 IPE Module	
From I/O panel	Cable A
	Cable B
	Cable C
	Cable D (Note)
	Cable E
	Cable F
	Cable G
	Cable H (Note)
	Cable K
	Cable L
	Cable M
	Cable N (Note)
	Cable R
	Cable S
Cable T	
Cable U (Note)	
Spare	
Spare	
Spare	
Spare	

Note: In NT8D37DC IPE Modules, these slots are not used. They are used in NT8D37EC IPE Modules.

553-3099

Figure 36
Sample basic BIX labels—NT8D37 IPE Modules

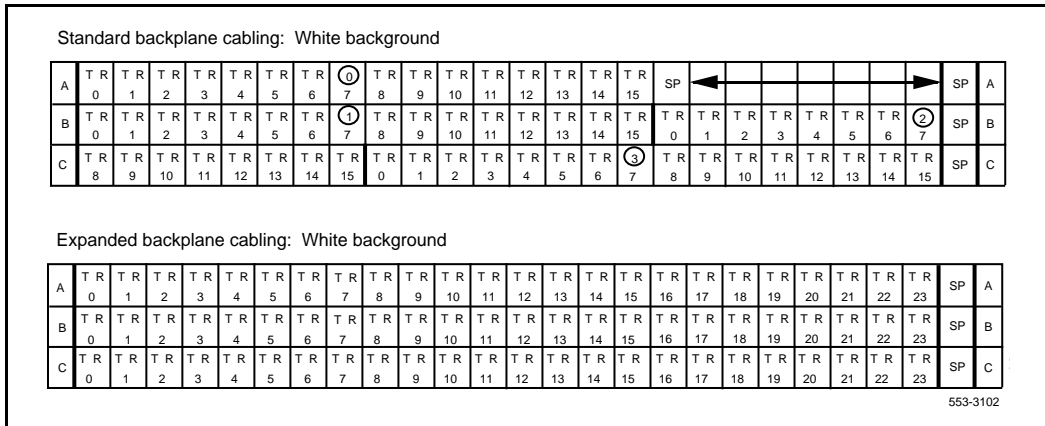

Figure 37
Sample overlay BIX labels—NT8D14 Universal Trunk Card

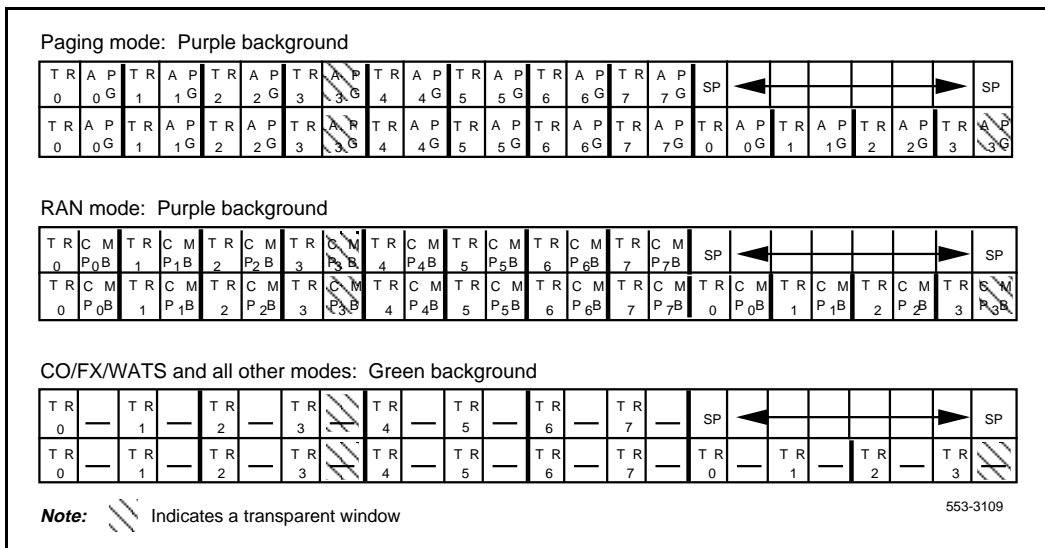

Figure 38
Sample overlay BIX labels—NT8D15 E&M Trunk Card

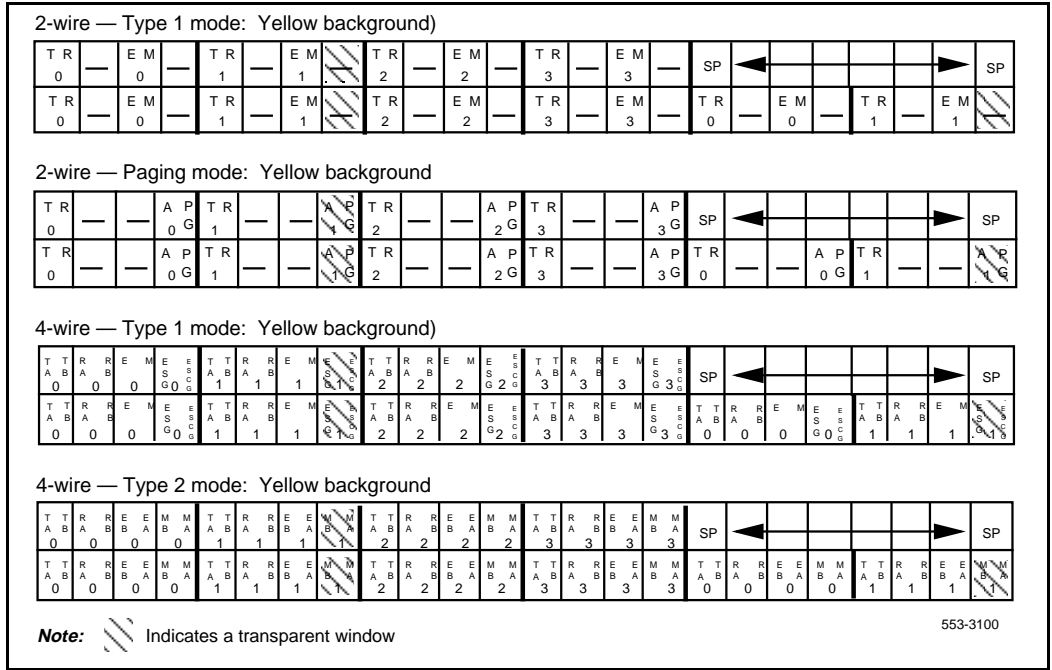
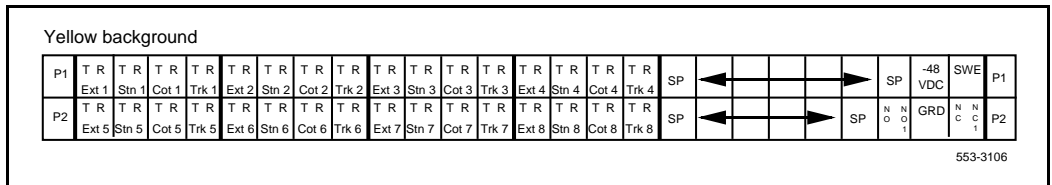

Figure 39
Sample BIX labels—PFTU



Backplane cable expansion

In the backplane configuration in NT8D11AC or NT8D11DC CE/PE and NT8D37AC or NT8D37DC IPE Modules, only some of the slots on the backplane are fully cabled to accommodate 24 tip and ring pairs (three cable connectors). Most of the backplane slots accommodate 16 pairs (two cable connectors). By adding and reconfiguring cable ends in the backplane slots, 24 pairs can be connected to each backplane slot.

With the 12-cable backplane configuration in the NT8D37AC and NT8D37DC IPE Modules, cable designations D, H, N, and U on the I/O panel are reserved for expansion (as shown in Figure 35 on page 75). Those cable designations are utilized in the 16-cable expanded configuration in NT8D37BA and NT8D37EC Modules.

When backplane slots are reconfigured for expanded cabling, the labeling for NT8D37 IPE Modules must be changed at the MDF to reflect the change in the backplane slots. Figure 36 on page 76 gives a sample of the basic BIX labels for NT8D37 IPE Modules with the standard backplane cabling configuration and with the expanded backplane cabling configuration.

Krone cross connect system (UK)

In the Krone cross connect system, one terminating strip holds 10 pairs of cable. When cross connecting a 25-pair cable on this system, 8 of the 10 terminating points are used on each strip. One 25-pair cable, therefore, occupies three terminating strips:

$$8 \text{ pairs per strip} \times 3 \text{ strips} = 24 \text{ pairs}$$

Card allocations

Figure 40 on page 79 and Figure 41 on page 80 provide module card allocations for the Krone cross connect system.

Labels

Terminating strips on the Krone cross connect must be labeled if they contain wiring. The labels that attach to the terminating strips have two sides: the front side shows the name of the card and the card number, the reverse side (flip-up side) shows pair designations for that card.

Figure 40
IPE module card allocation—Krone cross connect system

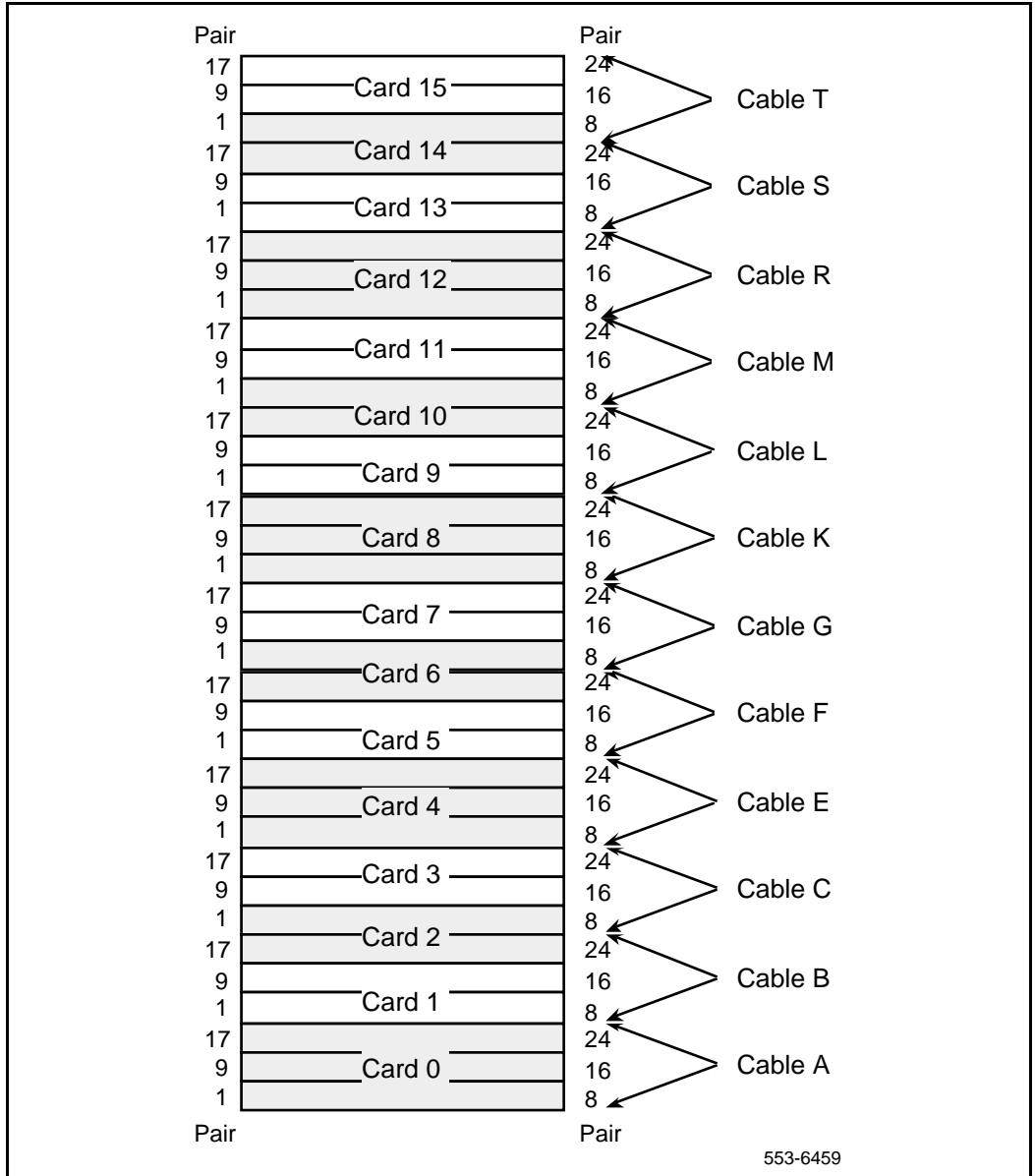
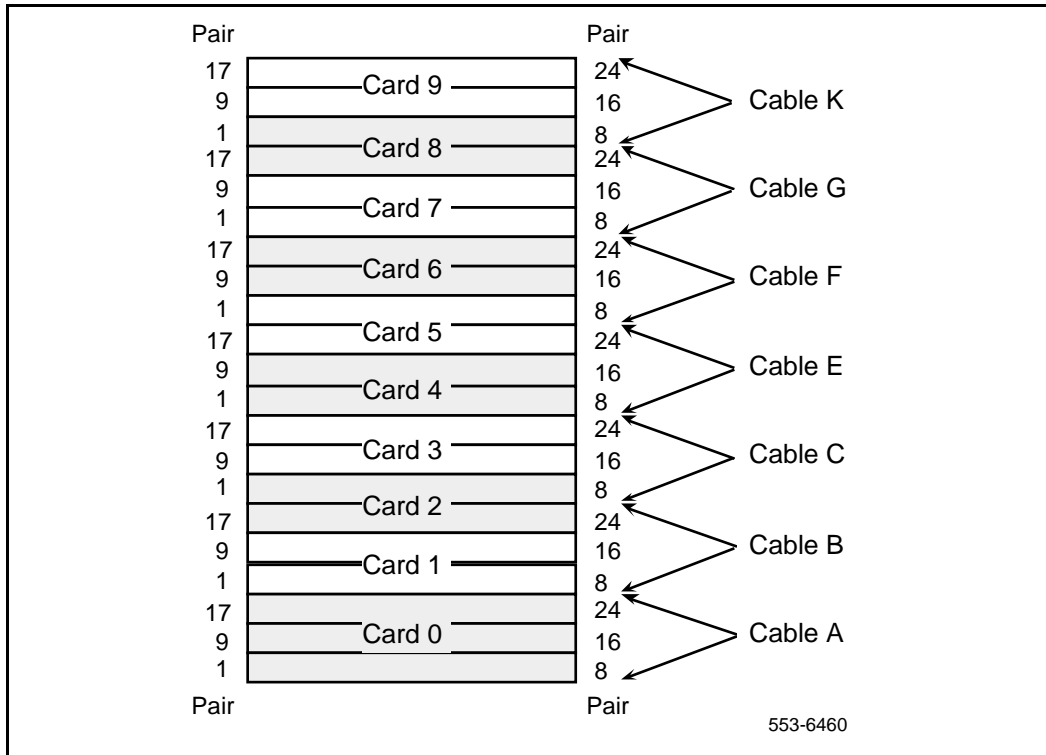

Figure 41
CE/PE module card allocation—Krone cross connect system



There are two types of mandatory labels: those with safety warnings and those without. Mandatory labels with safety warnings are required for the following cards:

- NT5K02 analog line card
- NT5K19 analog tie trunk card
- QUA6 Power Fail Transfer Unit (PFTU)

Labels are mandatory for the following cards but they do not need safety warnings:

- NT5K18 Exchange line card
- NT5K17 Direct Dial Inwards (DDI) card

Figure 42 on page 81 through Figure 48 on page 85 show labels for the Krone cross connect system.

Figure 42
Label for analog line card

SAFETY WARNING										LOOP.....
SEE INSTRUCTIONS FOR USE : ANALOGUE TELEPHONES										SHELF.....
										CARD.....
0	1	2	3	4	5	6	7	DIR. NO.'S		
T R	T R	T R	T R	T R	T R	T R	T R	T R	T R	
SAFETY WARNING										LOOP.....
SEE INSTRUCTIONS FOR USE : ANALOGUE TELEPHONES										SHELF.....
										CARD.....
8	9	10	11	12	13	14	15	DIR. NO.'S		
T R	T R	T R	T R	T R	T R	T R	T R	T R	T R	
SAFETY WARNING										LOOP.....
SEE INSTRUCTIONS FOR USE : ANALOGUE TELEPHONES										SHELF.....
										CARD.....
0	1	2	3	4	5	6	7	DIR. NO.'S		
T R	T R	T R	T R	T R	T R	T R	T R	T R	T R	

553-6461

Figure 45
Label for Power Fail Transfer Unit

SAFETY WARNING										POWER FAIL TRANSFER UNIT CABLE J1.					
SEE INSTRUCTIONS FOR USE															
A L M	G N D	P F T	G T N S D	T C	PFT 1										
								EXT	LINE CARD	CO TRK.	COT CARD				
T	R	T	R	T	R	T	R	T	R	T	R	T	R	T	R
SAFETY WARNING										POWER FAIL TRANSFER UNIT CABLE J1.					
SEE INSTRUCTIONS FOR USE															
PFT 2				PFT 3											
EXT	LINE CARD	CO TRK.	COT CARD	EXT	LINE CARD	CO TRK.	COT CARD								
T	R	T	R	T	R	T	R	T	R	T	R	T	R		
SAFETY WARNING										POWER FAIL TRANSFER UNIT CABLE J1.					
SEE INSTRUCTIONS FOR USE															
PFT 4				PFT 5				52	52						
EXT	LINE CARD	CO TRK.	COT CARD	EXT	LINE CARD	CO TRK.	COT CARD	V	V						
T	R	T	R	T	R	T	R	T	R	T	R	T	R		

553-6464

Figure 46
Label for Digital line card (NT8D02)

SAFETY WARNING										LOOP..... SHELF..... CARD.....			
SEE INSTRUCTIONS FOR USE : DIGITAL TELEPHONES													
								DIR. NO.'S					
0	1	2	3	4	5	6	7	T	R	T	R		
T	R	T	R	T	R	T	R	T	R	T	R	T	R
SAFETY WARNING										LOOP..... SHELF..... CARD.....			
SEE INSTRUCTIONS FOR USE : DIGITAL TELEPHONES													
								DIR. NO.'S					
8	9	10	11	12	13	14	15	T	R	T	R		
T	R	T	R	T	R	T	R	T	R	T	R	T	R

553-6465

Figure 47
Label for Exchange line trunk card (NT5K18)

EXCHANGE LINES					LOOP..... SHELF..... CARD.....
0 T R	1 T R	2 T R	3 T R	EXCHANGE NO.'S	
EXCHANGE LINES					LOOP..... SHELF..... CARD.....
4 T R	5 T R	6 T R	7 T R	EXCHANGE NO.'S	
EXCHANGE LINES					LOOP..... SHELF..... CARD.....
0 T R	1 T R	2 T R	3 T R	EXCHANGE NO.'S	

553-6466

Figure 48
Label for Direct Dial Inward trunk card (NT5K17)

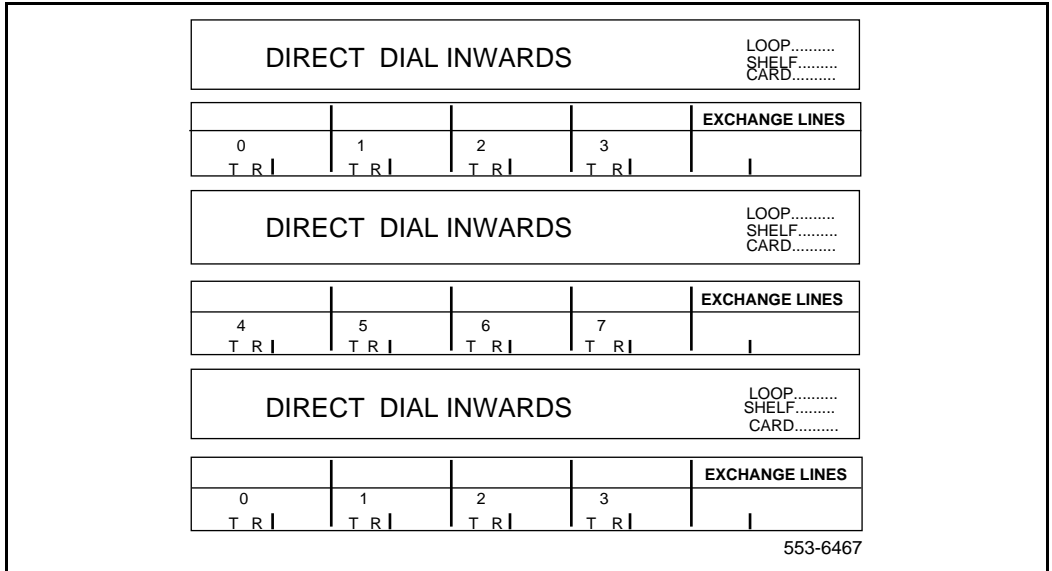

Installing PFTUs

Content list

The following are the topics in this section:

PFTU configurations	87
Connecting trunks and telephones	91
Installing QUA6 PFTUs (UK installations)	92

PFTU configurations

Use the PFTU manufacturer's instructions and this procedure to install and connect A0355200 Power Fail Transfer Units. In AC-powered systems, PFTUs are powered by the A0367916 Auxiliary –48V Power Supply (up to six PFTUs can be supported by one power supply). In DC-powered systems, PFTUs are powered from an auxiliary –48 V dc fused output from the external power equipment.

Figure 49 on page 88 shows a high-level view of PFTU alarm connections. For PFTU operation, wiring from the following equipment cross-connects through termination areas at the MDF:

- PFTU
- auxiliary power supply
- system monitor
- attendant console (optional)
- designated telephones (DTMF or rotary dial types)
- central office trunks

Figure 49
MDF terminations for typical PFTU operation

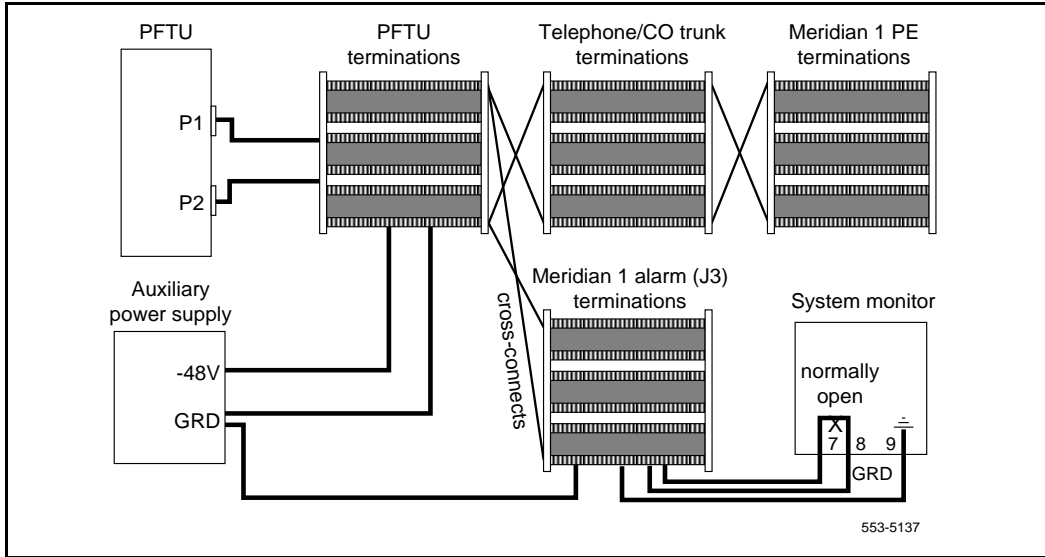

- 3 Attach the yellow PFTU label to the BIX designation strip, indicating the top BIX connector as P1 and the bottom connector as P2.
- 4 Install two NE-A25B type 25-pair cables from connectors P1 and P2 on the front of the PFTU to the PFTU termination area at the MDF.
- 5 Cross-connect wiring for PFTU operation as shown in Table 4 on page 90.

Table 4
MDF cross-connections for PFTU operations

Description	Connection
-48 V dc + return (GND)	PFTU connector P1, pin 49 PFTU connector P2, pin 49 and MDF GND
All grounds on system monitor cable	MDF GND
Console cable pin 11 Console cable pin 36	PFTU connector P1, pin 25 MDF GND
LFBEN (line forced bypass enable) LFBENR (line forced bypass enable return)	PFTU connector P1, pin 50 MDF GND
MDF GND	PFTU connector P2, pin 24
<p>Note: At connector P1 on the PFTU, pins 25 and 50 are labeled SWE for “switch enable.” When pin 25 is grounded by the attendant console or pin 50 is grounded by the system monitor, line transfer is activated.</p>	

- 6 For AC-powered systems, install the A0367916 auxiliary power supply:
- Attach the unit to the wall using screws in the four mounting holes.
 - Connect a #24 (or larger) AWG wire from the –48 V connection on the auxiliary power supply to the PFTU termination area on the MDF.
 - Connect a #24 (or larger) AWG wire from the ground (GND) connection on the auxiliary power supply to the PFTU termination area on the MDF.
 - Connect a second #24 (or larger) AWG wire from the GND connection on the auxiliary power supply to the Meridian 1 alarm termination area on the MDF.
 - Plug in the A0367916 auxiliary power supply:

If a UPS is used, you must plug the power supply into an auxiliary output on the UPS.

Without a UPS, plug the power supply into an outlet in the equipment room.

- 7 For DC-powered systems, power the PFTU from the fused low-current auxiliary power outputs on the DC power system. One 1.33-amp fuse supports up to six PFTUs.

Connecting trunks and telephones

The “ground start” feature on 500/2500-type telephones connected to CO trunks requiring a ground start condition is not required. Automatic ground start is performed by the PFTU. However, rotary dials (dial pulse) are required on telephones assigned to trunks that are not equipped to recognize tone pulses (touch tone).

See the PFTU documentation for MDF cable terminations for telephones and trunks associated with the PFTU. If the connections are not designated on the connecting blocks, mark the blocks as shown in the documentation or install the appropriate designation strips.

- 1 For each telephone assigned to the PFTU:
- Connect the tip and ring of the line card to the first pair of the assigned PFTU.
 - Connect the tip and ring of the telephone to the second pair of the assigned PFTU.

- 2 For each trunk assigned to the PFTU:
 - Connect the tip and ring of the CO card to the third pair of the assigned PFTU.
 - Connect the tip and ring of the trunk to the fourth pair of the assigned PFTU.

Installing QUA6 PFTUs (UK installations)

QUA6 PFTUs are used in United Kingdom Meridian 1 installations. The QUA6 PFTU is powered from an auxiliary –48V dc fused output from the external power equipment.

Figure 49 on page 88 shows a high-level view of QUA6 PFTU alarm connections. For PFTU operation, wiring from the following equipment cross-connects through termination areas at the MDF:

- PFTU
- auxiliary –48 V dc
- system monitor
- attendant console (optional)
- designated telephones
- Central Office trunks

Configuring the system monitor

Content list

The following are the topics in this section:

Reference list	93
Configuring the NT8D22 System Monitor	93
Cabling the NT8D22 System Monitor	97

Reference list

The following are the references in this section:

- *Circuit Card: Installation and Testing* (553-3001-211)

Configuring the NT8D22 System Monitor

The master NT8D22 System Monitor interfaces with a Serial Data Interface (SDI) port in the column with CPU 0.

- 1 Set the baud rate for the SDI port associated with the system monitor to 1200 baud in DTE mode.
- 2 In the rear of the pedestal, loosen the two retaining screws on the system monitor and remove it from the PDU.
- 3 Set the option switches for each system monitor. (See *Circuit Card: Installation and Testing* (553-3001-211) for a detailed description of switch setting options.)
 - a. **For a single-column system**, set the switches as shown in Table 5 on page 94.

Note: Connect and cable the system monitor in a single-column system like a master system monitor for the rest of this procedure.

Table 5
NT8D22 switch settings for a single-column system

Switch	1	2	3	4	5	6	7	8
SW1	off	off	*	on**	off	off	off	off
SW2	on	off	on	on	on	on	on	on
SW3	on	on	on	on				
*	Set to on for a DC-powered system; set to off for an AC-powered system.							
**	Set to off if the system is not equipped with a PFTU.							

- b. **For a multiple-column system**, set the system monitor in the column with CPU 0 as the master, using the settings shown in Table 6 on page 94 and Table 8 on page 95.
- c. Set option switches on slave system monitors as shown in Table 7 on page 95 and, Table 9 on page 96. If CPU 0 and CPU 1 are in different columns, set the system monitor in the column with CPU 1 as slave unit 1. Number the slaves sequentially wherever possible.

Table 6
Switch settings for *master* in multiple-column system

Switch	1	2	3	4	5	6	7	8
SW1	off	off	*	on**	off	off	off	off
SW2	on	off	To set positions 3–8, see Table 8 on page 95					
SW3	on	on	on	on				
*	Set to on for a DC-powered system; set to off for an AC-powered system.							
**	Set to off if the system is not equipped with a PFTU.							

Table 7
Switch settings for *slaves* in multiple-column system

Switch	1	2	3	4	5	6	7	8
SW1	off	off	*	**	off	off	off	off
SW2	off	off	To set positions 3–8, see Table 9 on page 96					
SW3	off	off	off	off				
* Set to on for a DC-powered system; set to off for an AC-powered system. ** Set to on to enable PFTU (if equipped) during over-temperature condition. Set to off to disable PFTU during over-temperature condition.								

Table 8
SW2 on *master*—total number of slaves in the system (Part 1 of 2)

How many slave units	Switch position						How many slave units	Switch position					
	3	4	5	6	7	8		3	4	5	6	7	8
0	on	on	on	on	on	on	32	off	on	on	on	on	on
1	on	on	on	on	on	off	33	off	on	on	on	on	off
2	on	on	on	on	off	on	34	off	on	on	on	off	on
3	on	on	on	on	off	off	35	off	on	on	on	off	off
4	on	on	on	off	on	on	36	off	on	on	off	on	on
5	on	on	on	off	on	off	37	off	on	on	off	on	off
6	on	on	on	off	off	on	38	off	on	on	off	off	on
7	on	on	on	off	off	off	39	off	on	on	off	off	off
8	on	on	off	on	on	on	40	off	on	off	on	on	on
9	on	on	off	on	on	off	41	off	on	off	on	on	off
10	on	on	off	on	off	on	42	off	on	off	on	off	on
11	on	on	off	on	off	off	43	off	on	off	on	off	off
12	on	on	off	off	on	on	44	off	on	off	off	on	on
13	on	on	off	off	on	off	45	off	on	off	off	on	off
14	on	on	off	off	off	on	46	off	on	off	off	off	on
15	on	on	off	off	off	off	47	off	on	off	off	off	off
16	on	off	on	on	on	on	48	off	off	on	on	on	on
17	on	off	on	on	on	off	49	off	off	on	on	on	off
18	on	off	on	on	off	on	50	off	off	on	on	off	on

Table 8
SW2 on *master*—total number of slaves in the system (Part 2 of 2)

How many slave units	Switch position						How many slave units	Switch position					
	3	4	5	6	7	8		3	4	5	6	7	8
19	on	off	on	on	off	off	51	off	off	on	on	off	off
20	on	off	on	off	on	on	52	off	off	on	off	on	on
21	on	off	on	off	on	off	53	off	off	on	off	on	off
22	on	off	on	off	off	on	54	off	off	on	off	off	on
23	on	off	on	off	off	off	55	off	off	on	off	off	off
24	on	off	off	on	on	on	56	off	off	off	on	on	on
25	on	off	off	on	on	off	57	off	off	off	on	on	off
26	on	off	off	on	off	on	58	off	off	off	on	off	on
27	on	off	off	on	off	off	59	off	off	off	on	off	off
28	on	off	off	off	on	on	60	off	off	off	off	on	on
29	on	off	off	off	on	off	61	off	off	off	off	on	off
30	on	off	off	off	off	on	62	off	off	off	off	off	on
31	on	off	off	off	off	off	63	off	off	off	off	off	off

Table 9
SW2 on each *slave*—unit number for the slave (Part 1 of 2)

Slave unit address	Switch position						Slave unit address	Switch position					
	3	4	5	6	7	8		3	4	5	6	7	8
1	on	on	on	on	on	off	33	off	on	on	on	on	off
2	on	on	on	on	off	on	34	off	on	on	on	off	on
3	on	on	on	on	off	off	35	off	on	on	on	off	off
4	on	on	on	off	on	on	36	off	on	on	off	on	on
5	on	on	on	off	on	off	37	off	on	on	off	on	off
6	on	on	on	off	off	on	38	off	on	on	off	off	on
7	on	on	on	off	off	off	39	off	on	on	off	off	off
8	on	on	off	on	on	on	40	off	on	off	on	on	on
9	on	on	off	on	on	off	41	off	on	off	on	on	off
10	on	on	off	on	off	on	42	off	on	off	on	off	on
11	on	on	off	on	off	off	43	off	on	off	on	off	off
12	on	on	off	off	on	on	44	off	on	off	off	on	on
13	on	on	off	off	on	off	45	off	on	off	off	on	off

Table 9
SW2 on each *slave*—unit number for the slave (Part 2 of 2)

Slave unit address	Switch position						Slave unit address	Switch position					
	3	4	5	6	7	8		3	4	5	6	7	8
14	on	on	off	off	off	on	46	off	on	off	off	off	on
15	on	on	off	off	off	off	47	off	on	off	off	off	off
16	on	off	on	on	on	on	48	off	off	on	on	on	on
17	on	off	on	on	on	off	49	off	off	on	on	on	off
18	on	off	on	on	off	on	50	off	off	on	on	off	on
19	on	off	on	on	off	off	51	off	off	on	on	off	off
20	on	off	on	off	on	on	52	off	off	on	off	on	on
21	on	off	on	off	on	off	53	off	off	on	off	on	off
22	on	off	on	off	off	on	54	off	off	on	off	off	on
23	on	off	on	off	off	off	55	off	off	on	off	off	off
24	on	off	off	on	on	on	56	off	off	off	on	on	on
25	on	off	off	on	on	off	57	off	off	off	on	on	off
26	on	off	off	on	off	on	58	off	off	off	on	off	on
27	on	off	off	on	off	off	59	off	off	off	on	off	off
28	on	off	off	off	on	on	60	off	off	off	off	on	on
29	on	off	off	off	on	off	61	off	off	off	off	on	off
30	on	off	off	off	off	on	62	off	off	off	off	off	on
31	on	off	off	off	off	off	63	off	off	off	off	off	off
32	off	on	on	on	on	on	58	off	off	off	on	off	on

Cabling the NT8D22 System Monitor

- 1 Remove the I/O safety panel in the rear of the module with CPU 0.
- 2 Connect the master system monitor to the SDI port.
 - a. **For Options 51C and 61C**, connect the narrow ribbon on one of the cables listed below from connector J2 on the backplane to the assigned port on the SDI card (see Figure 51 on page 98).
 - To connect an NT8D41 SDI Paddle Board, use an NT8D46AG cable.
 - To any other type of SDI card, use an NT8D46AD cable.
 - b. For Option 81C

Figure 51
Options 51C and 61C—
cable master system monitor to SDI port

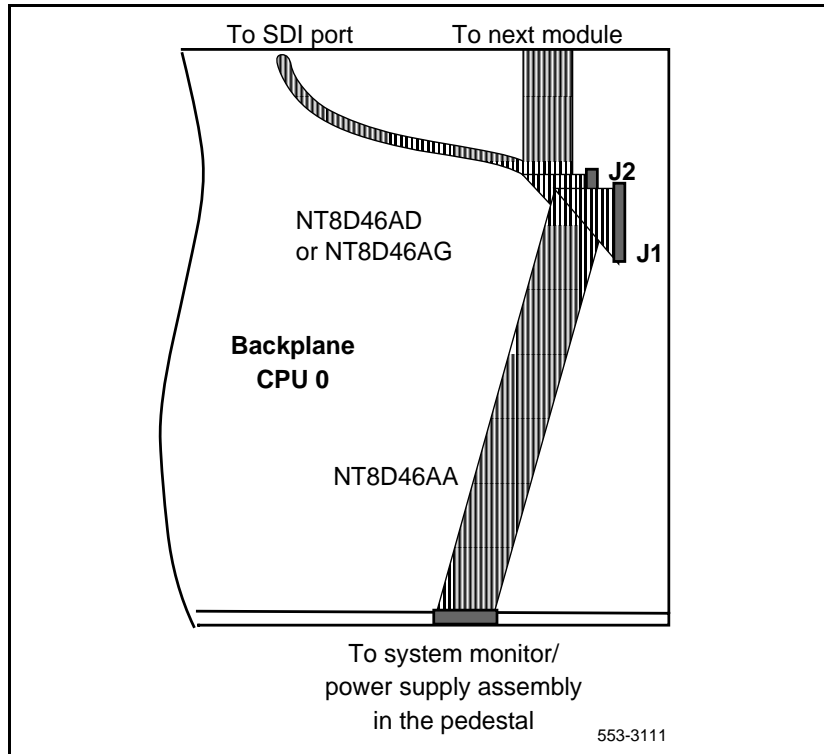

— Connect the master system monitor to slave unit 1 with an NT8D46AS cable.

— Connect the narrow ribbon on an NT8D46AD cable from connector J2 in the module with CPU 0 to the assigned port on the SDI card (see Figure 52 on page 99).

- 3 Daisy-chain slave system monitors to the master.
 - a. **For a single-column system**, skip this step.

Figure 52
Option 81C—cabling for master system monitor to slave unit 1 and SDI port

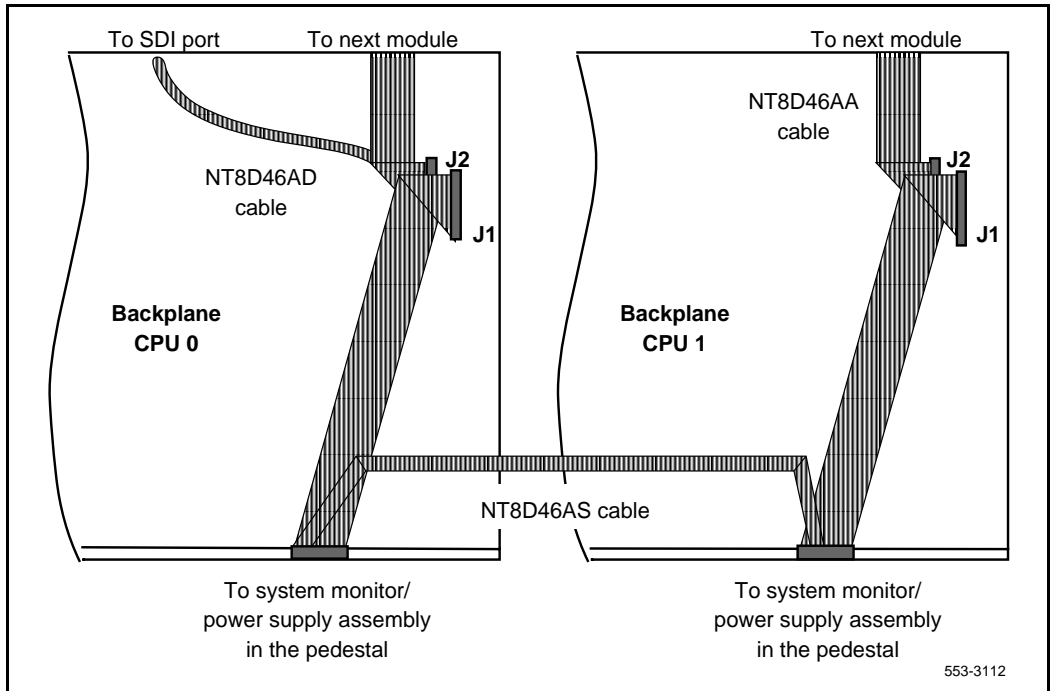

- b. For a multiple-column system**, beginning with the master system monitor, cable in series (slave 1 to slave 2, slave 2 to slave 3, and so on) from connector J6 to connector J5 on each system monitor (see Figure 53 on page 100). Terminate at connector J5 on the last column.

- If columns are adjacent, use an NT8D46AL cable.
- If columns are not adjacent, use an NT8D46AP cable.

- 4** For PFTU or external alarm cabling, connect a system monitor to MDF cable:

- Connect a system monitor to MDF cable to connector J3 on the master system monitor.
- Connect the cable at the Meridian 1 alarm termination area at the MDF. See Table 10 on page 101 for the terminating sequence.

Figure 53
Multiple-column system monitor connections

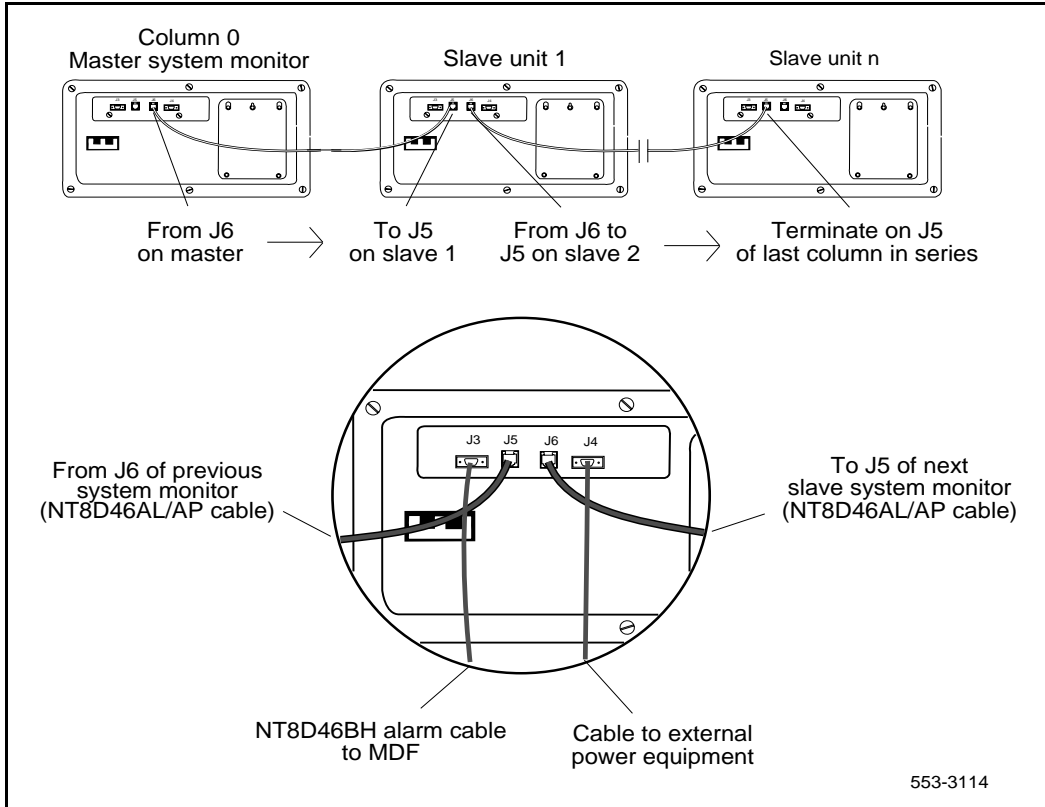

Note 1: The system monitor to MDF cable is available in three lengths: NT8D46BH (32 ft), NT8D46EH (100 ft), and NT8D46DH (150 ft).

Note 2: If additional contact closures are required through the J3 REMALMA or REMALMB leads (for a hard alarm in case a column loses power, for example), additional system monitor to MDF cables can be ordered.

Table 10
NT8D22 System Monitor— pin assignments at J3

Pin	Direction	Color	Signal name	Description
1	out	BL/W	REMALMA	Remote major alarm (connect for external alarm)
2	out	OR/W	REMALMB	Remote major alarm return (connect for external alarm)
3	out	GR/W	CE-SYSLT	CE system line transfer (upgraded systems only)
4	—	BR/W	MDF0/GND	MDF return (ground)
5	in	SL/W	CEALMIN	CE alarm (upgraded systems only)
6	—	BL/R	SYSLTIN	System line transfer in (upgraded systems only)
7	out	W/BL	LFBEN	Line forced bypass enable (connect for PFTU operation)
8	out	W/OR	LFBENR	Line forced bypass enable return (connect for PFTU operation)
9	—	W/GR	GND	Ground

Note: Pins 6, 8, and 9 should be connected and grounded at the MDF.

- 5 For AC-powered systems with a UPS:
 - Connect the appropriate cable (see the following list) from connector J4 on the system monitor in the column with CPU 0 (the master system monitor) to the associated UPS. Table 11 on page 102 gives the pin assignments and signal descriptions for the alarm cables.
 - a. For a Best Inc. UPS, use an NT8D46AJ alarm cable.

- b. For an Exide UPS, use an NT8D46AQ alarm cable.
- c. For an Alpha UPS, use an NT8D46AU alarm cable.
- Connect the cable to the UPS as specified by the manufacturer.
- Repeat this step for each system monitor with an associated UPS (see Figure 54 on page 103).

Table 11
NT8D22 System Monitor— pin assignments at J4

Pin	Signal description
1	Not used
2	Not used
3	Not used
4	Not used
5	Alarm 1 (AC fail; to UPS)
6	Alarm 1 return
7	Alarm 2 (Power sense; from UPS)
8	Alarm 2 return
9	Not used

Figure 54
UPS alarm cabling

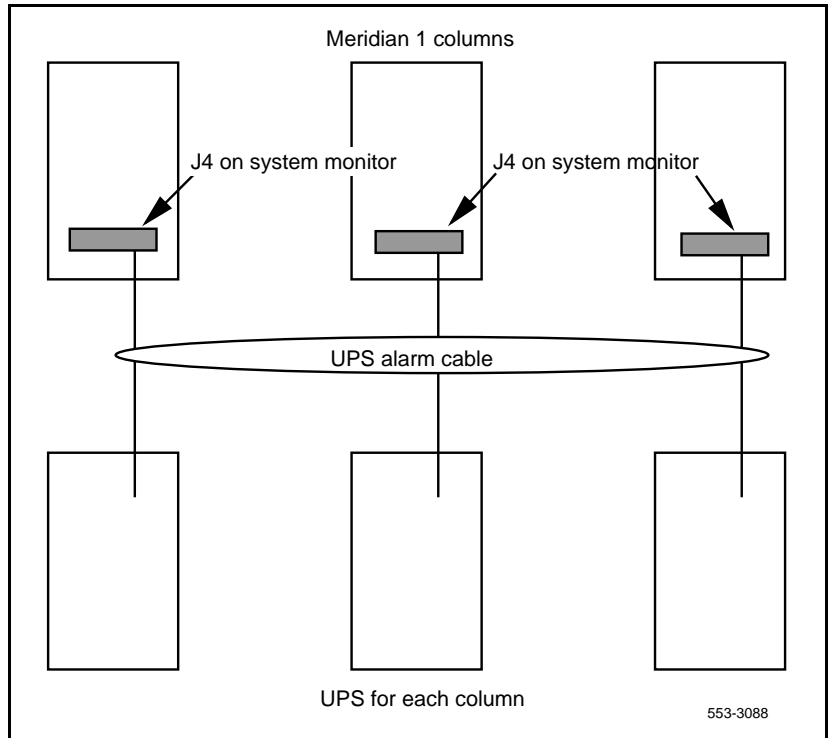

- 6** For DC-powered systems, extend the alarm and trip leads from connector J4 on the system monitor in the column with CPU 0 (the master system monitor) to the external power equipment using an NT8D46AV cable (Table 12 on page 104).

Note 1: Conduit is not required.

Note 2: An NT8D46BV cable, 20 m (64 ft), or NT8D46CV cable, 33 m (100 ft), can be used instead of the NT8D46AV cable. Connections are the same as the NT8D46AV cable.

Table 12
Alarm and trip lead connections—NT8D46AV cable

Color	Description	Connection at control and distribution panel	
		Terminal block No	Pwr Sys Alarm Name
OR	Alarm	TB2 Position 6	Low Float
BL	DCON 0	TB4 Position 8	Rectifier Fail Alarm
R	DCON 1*	TB5 Position 2	Major Alarm
W	DCON 2*	TB5 Position 2	Major Alarm
GR	DCON 3*	TB5 Position 2	Major Alarm

* Connect the red, white, and green wires together at MJA.

The System 600/48 Power Plant produces a Major Alarm for the following faults:

- High voltage shut down (HVSD)
- High voltage (HV)
- Battery on discharge (BOD)
- Low voltage (LV)
- Low voltage disconnect (LVD)
- Alarm busy supply (ABSF)
- Internal fuse alarm (INT FA)
- Fuse alarm (FA)
- Rectifier fail alarm (RFA)

Connecting a system terminal (or modem)

Content list

The following are the topics in this section:

Reference list	105
System Terminal	105
Options 51C, 61C, and 81C terminal and modem connections	107
Configuring the US Robotics 33.5 Data/Fax modem	115
Connecting a modem to an SDI port	116
Connecting a modem to a switch box, CPSI/COM 2 and SDI ports	118

Reference list

The following are the references in this section:

- *Circuit Card: Installation and Testing* (553-3001-211)

System Terminal

At this point in the installation, a terminal must be connected to a serial data interface (SDI) port to provide an I/O interface to the system. When the installation is complete, a terminal (for local access) or a modem (for remote access) must remain permanently connected to an SDI port to provide a constant I/O interface to the system (see Figure 55 on page 106).

During the initial installation of a dual CPU system, you may want to temporarily install additional terminals for split mode monitoring, or programming, or both.

Figure 55
Terminal connection diagram

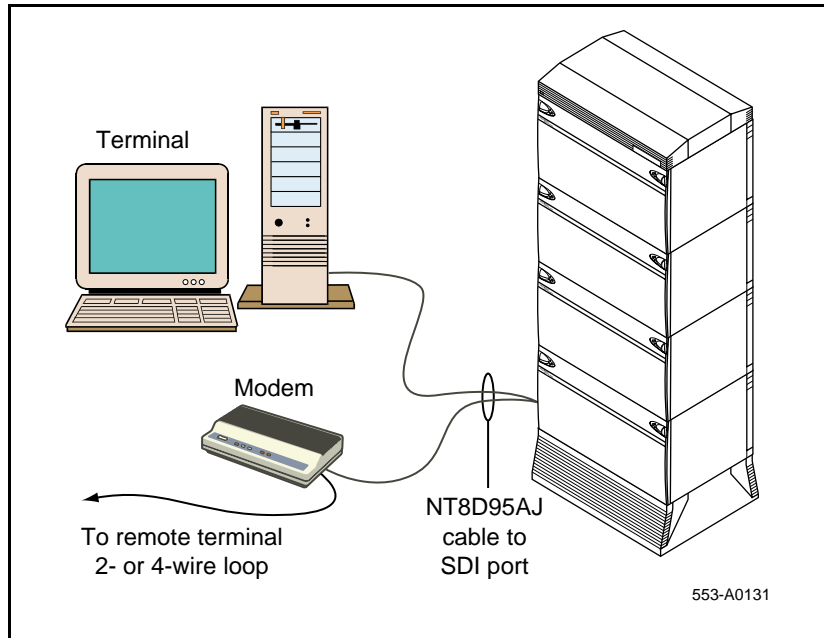

Note: In Options 51C, 61C, and 81C, I/O ports on the Call Processing (CP) Cards can be used to monitor CPU operations. These configurations should not be used as the permanent I/O connection for the system because the port is only active when the associated CPU, or CPU, is active.

Options 51C, 61C, and 81C terminal and modem connections

During the system installation and for continuing system operation, a terminal must be connected to an SDI port in a network slot to provide an I/O interface to the active CPU in the system. In addition, a data terminal equipment (DTE) port and a data communication equipment (DCE) port on each CP Card card can be used for direct access to the Core/Network Module of Option 51C, and 61C. The COM 1 (DTE port) or COM 2 (DCE port) on the Call Processor Pentium II (CP PII) card can be used for direct access of the cPCI Core/Network Module of the Option 81C. Typically, the CP card ports (CPSI ports) ports or COM1 and COM2 are preconfigured on I/O addresses four and five.

The CCPSI/COM1 and COM2 ports are active only when the CPU associated with the CP card is active. Therefore, the CPSI/COM1 and COM2 ports should not be used as the only I/O connection for the system.

When the initial installation is complete, you must leave a terminal or a modem connected to the system. One SDI port in a network slot must be permanently connected to a terminal or modem. On the CPSI/COM1 and COM2 ports you can:

- disconnect the ports
- leave terminals connected for local monitoring
- connect modems for remote monitoring

The Black Box ABCDE-Switch, which provides up to four-to-one switching, is available from Nortel Networks as part number A0377992. The switch box can be used to connect the SDI and CPSI/COM1 and COM2 ports to a terminal or a modem. If used, one switch box must be used for terminals and one for modems.

Options 51C, 61C, and 81C terminal guidelines

During an installation, you can connect terminals to the CPSI/COM1 ports for split mode monitoring, or programming, or both. (Due to the speed of the system messages displayed, personal computers are useful for file capture and review.) Terminals connected to the CPSI/COM1 ports can be installed as follows:

- one terminal connects to a CPSI/COM1 port in one CPU (the cable is switched from module to module as needed); one terminal is required in addition to the terminal for the SDI port connection (see Figure 56 on page 109)
- one terminal connects to a switch box that connects to a CPSI/COM1 port in each CPU: one terminal and a switch box are required in addition to the terminal for the SDI port connection (see Figure 57 on page 111)
- one terminal connects to a switch box that connects to an SDI port and to a CPSI/COM1 port in each CPU: one terminal and a switch box are required (see Figure 58 on page 113)

The Option 51C has only one CPU module and requires only one CPSI terminal connection and one SDI port connection. A single terminal with a switch box can be used.

Connecting a terminal to a CPSI port

Use the following procedure to connect a CPSI/COM1 port directly (no switch box) to a terminal (see Figure 56 on page 109):

- 1** Set the terminal to 9600 baud, 7 data, space parity, one stop bit, full duplex, XON.
- 2** Connect an NT8D95 cable to a matching connector on the terminal.
- 3** Connect the NT8D95 cable to J25 on the I/O panel in the rear of the Core/Network Module or cPCI Core/Network Module.
- 4** If you are using only one terminal for both CPSI/COM1 ports, switch the cable as needed. The terminal connected to the SDI port will always communicate with whichever CPU is active.

Figure 56
One terminal for the CPSI/COM1 ports

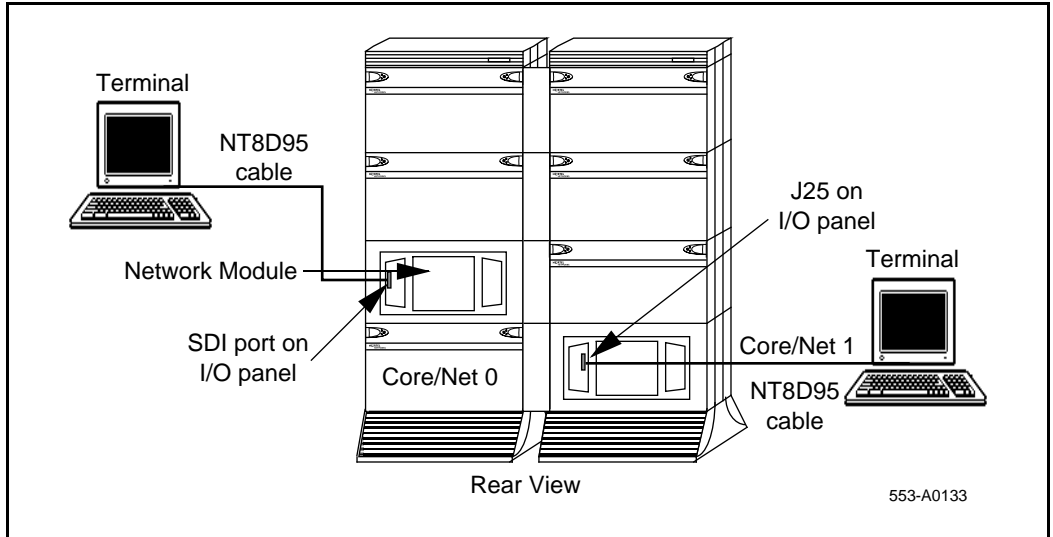

Connecting a switch box and terminal to CPSI/COM1 and COM2 ports

Use the following procedure to connect CPSI/COM1 ports to a switch box and a terminal (see Figure 57 on page 111):

- 1 Set the terminal to 9600 baud, 7 data, space parity, one stop bit, full duplex, XON.
- 2 Connect an NT8D95 cable to the terminal and to the switch box.
- 3 Connect NT8D95 cables to a matching connector on the switch box.
 - a. If you are using an A0377992 ABCDE box, connect cables as follows:
 - Connect CPU 0 to connector A.
 - Connect CPU 1 to connector B.
- 4 Connect the NT8D95 cables from the switch box to J25 on the I/O panel in the rear of the Core/Network Modules or cPCI Core/Network Modules.
- 5 To communicate directly with a CPSI/COM1 port, switch the cable as needed. The terminal connected to the SDI port will always communicate with whichever CPU is active.

Figure 57
One terminal and a switch box to two CPSI/COM1 ports

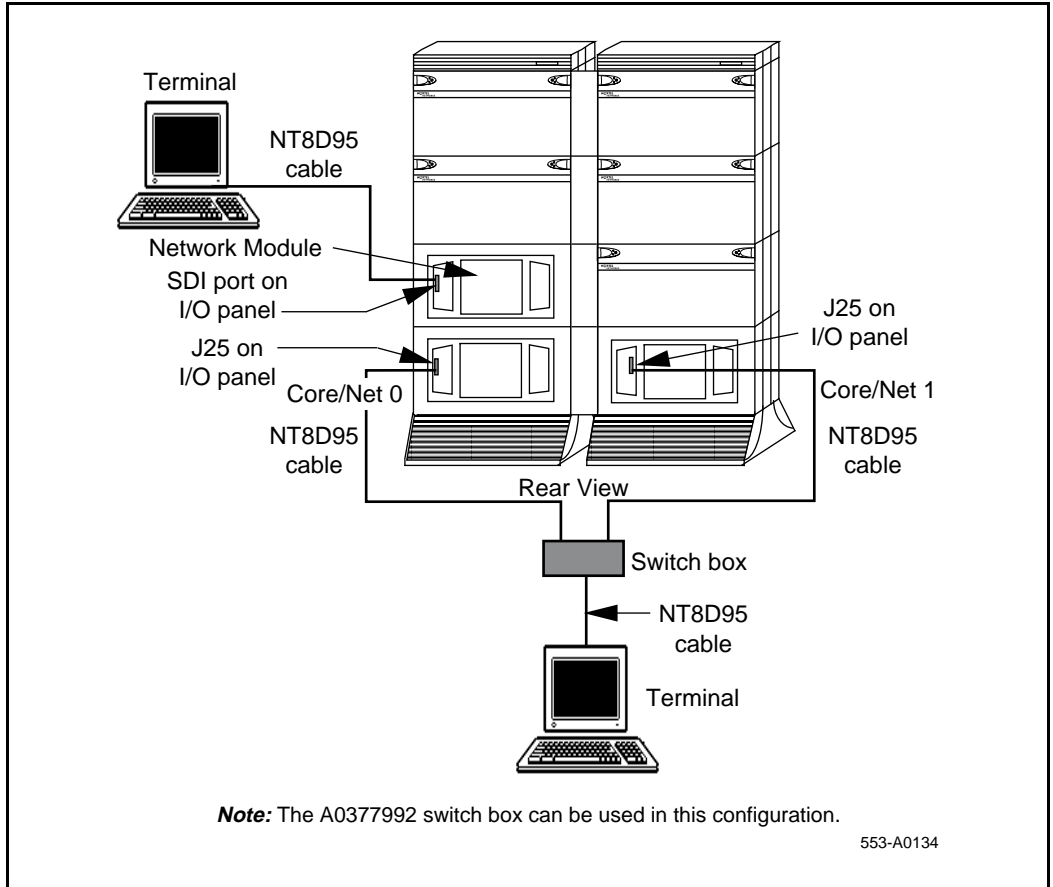

Connecting a switch box and terminal to the SDI and CPSI/COM1 ports

Use the following procedure to connect CPSI/COM1 ports to a switch box and a terminal (see Figure 57 on page 111 and Figure 58 on page 113):

- 1 Set the terminal to 9600 baud, 7 data, space parity, one stop bit, full duplex, XON.
- 2 Connect an NT8D95 cable to the terminal and to the switch box.
- 3 Connect NT8D95 cables to a matching connector on the switch box.
 - a. If you are using an A0377992 ABCDE box, connect cables as follows:
 - Connect CPU 0 to connector A.
 - Connect CPU 1 to connector B.
 - Connect the SDI port to connector D (connector C is common).
- 4 Connect NT8D95 cables from the switch box to J25 on the I/O panel in the rear of each Core/Network Module or cPCI Core/Network Modules.
- 5 Connect an NT8D95 cable from the switch box to the I/O panel slot for the SDI card.
- 6 To communicate with the system in general, set the switch box to the SDI port. To communicate directly with a CPSI COM1 port, switch the cable as needed.

Figure 58
One terminal and a switch box to the SDI and CPSI/COM 1 ports

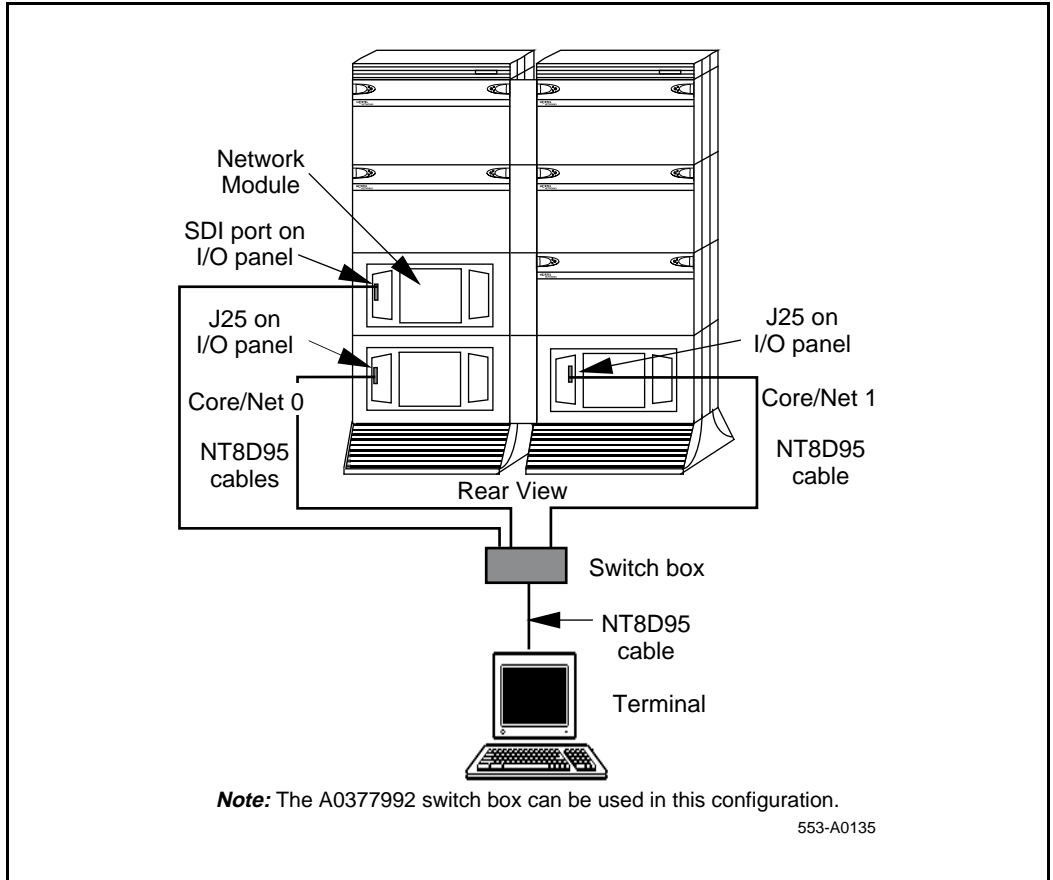

Options 51C, 61C, and 81C modem guidelines

You can connect a modem to an SDI port to remotely monitor general system operation. Or you can connect a modem to the CPSI ports for debugging and patch downloading (through your Nortel Networks representative). Or you may want a remote connection to both the SDI and CPSI/COM 2 ports.

At the Meridian 1 end (the local end), modems must be set to dumb mode (command recognition OFF, command echo OFF). Modems at the local end can be connected as follows:

- one modem connects to the SDI port and the cable is switched to each CPSI/COM 2port as needed (see Table 59 on page 117)
- one modem connects to a switch box that connects to the SDI and CPSI/COM 2 ports (see Table 60 on page 120)

Note: The second method listed here is preferred. Other configurations, such as a separate modem for each port, are possible.

At the remote end, at least one modem (which can be set to smart mode), one terminal, and one RS-232 cable are required in all modem configurations.

Modems at the local end must meet the following required specifications to be compatible with options 51C, 61C, and 81C. Modems that meet the following recommended specifications must also meet the required specifications.

- *Required:* true, not buffered, 9600 baud support (required for remote Nortel Networks technical support)
- *Required:* CCITT V.32 or V.32bis compliance
- *Recommended:* the ability to adjust to lower and higher speeds, depending on line quality, while maintaining 9600 baud at local DTE
- *Recommended:* V.42 error correction
- *Recommended:* V.42 bis data compression

A dispatch or call back modem, normally connected to the SDI port, can be used if it meets the requirements. If you want to use a modem of this type that does not meet the requirements, the modem can only be used in addition to a modem that does meet specifications.

Any modem that meets the required specifications should be compatible with options 51C, 61C, and 81C. The US Robotics, Sportster External 33.5 Data/Fax modem model is tested and verified as compatible. The US Robotics, Sportster External 33.5 Data/Fax modem is available through Nortel Networks as part number A0663901.

Configuring the US Robotics 33.5 Data/Fax modem

Use the following procedure to configure a US Robotics, Sportster External 33.5 Data/Fax modem for operation with Options 51C, 61C, 81, and 81C. This procedure must be done before you connect the modem to the Meridian 1 system. You need a terminal such as a PC computer, to configure the modem.

- 1** Turn the modem off.
- 2** Set the modem DIP switches as follows:
 - DIP switches 1, 3, 7, and 8 to ON (down).
 - DIP switches 2, 4, 5, and 6 to OFF (up).
- 3** Connect an RS-232 cable to the modem and to a terminal.
- 4** Set the terminal with the following values:
 - 9600 baud
 - 8 bits
 - 1 stop bit
 - no parity

- 5 Turn the modem on and enter each command listed below with a carriage return (press Enter or Return key):
- AT&F Load active profile
 - AT&H0 Flow control disabled
 - AT&D3 Resets on receipt of DTR
 - AT&S1 Modem controls DSR
 - ATS0=1 Answer after 1 ring
 - ATS2=128Escape character = ASCII 128
 - ATS7=60Pause 1s for carrier detection
 - ATQ1 Quiet mode
 - AT&W Store active profile

The modem responds **OK** to every command (except for the last two commands ATQ1 and AT&W).

- 6 Disconnect the power cord and serial from the modem.
- 7 Set DIP switches 1 and 4 to ON (down) and the remaining switches OFF (up).

Connecting a modem to an SDI port

Use the following procedure to connect an SDI port directly (no switch box) to a modem (see Figure 59 on page 117):

- 1 At the remote end, connect an RS-232 cable to the terminal and to the modem.
- 2 At the remote end, connect the cable from the modem to an RJ11 telephone jack. (If a cable is required, connect an NT8D46 cable to the modem and to the RJ11 jack.)
- 3 At the local end, configure the modem:
 - Follow the manufacturer's instructions to set the modem for 9600 baud, autoanswer, dumb mode, command recognition OFF, command echo OFF.
- 4 At the local end, connect an NT8D95 cable to the SDI port on the I/O panel in the rear of the module and to the modem.

- 5 At the local end, connect the cable from the modem to an RJ11 telephone jack. (If a cable is required, connect an NT8D46 cable to the modem and to the RJ11 jack.)
- 6 To communicate with a CPSI/COM 2 port, switch the cable from the modem to the port as needed:
 - For debugging or monitoring, connect the cable to the *active* CPU at J21 on the I/O panel in the rear of the Core/Network Module or cPCI Core/Network Module.
 - For patch downloading, connect the cable to the *inactive* CPU at J21 on the I/O panel in the rear of the Core/Network Module or cPCI Core/Network Module.

Figure 59
Modem to SDI port

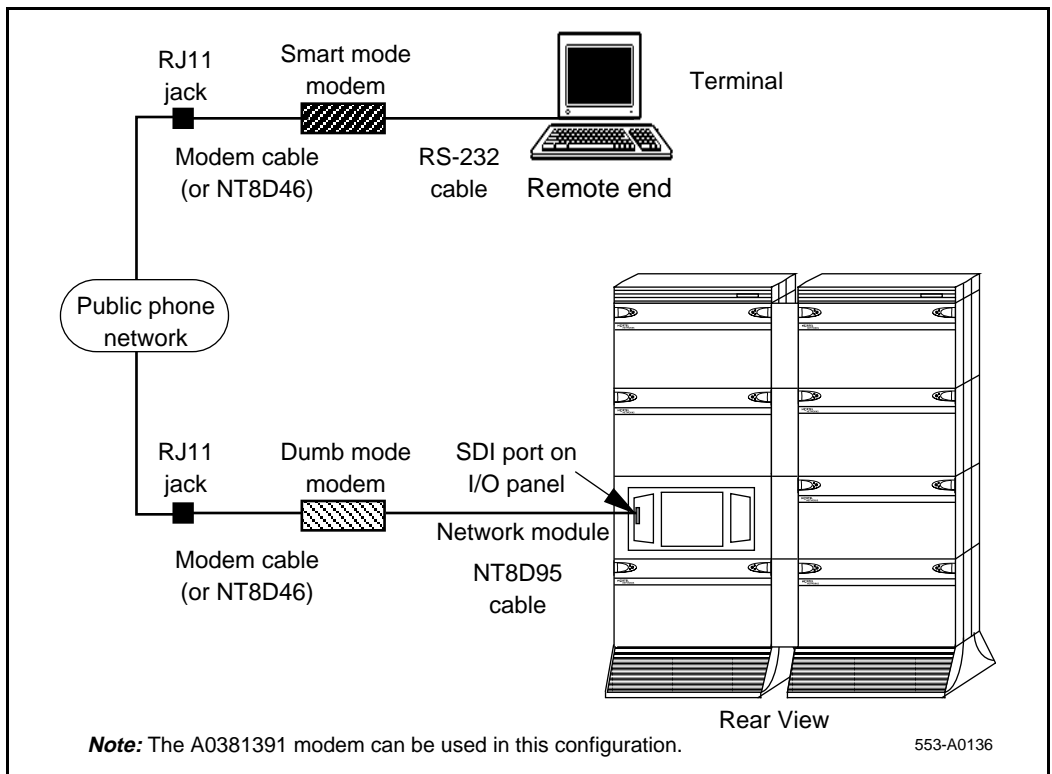

Connecting a modem to a switch box, CPSI/COM 2 and SDI ports

Use the following procedure to connect SDI and CPSI/COM 2 ports to a switch box and a modem (see Figure 60 on page 120 and Figure 61 on page 121):

- 1 At the remote end, connect an RS-232 cable to the terminal and to the modem.
- 2 At the remote end, connect the cable from the modem to an RJ11 telephone jack. (If a cable is required, connect an NT8D46 cable to the modem and to the RJ11 jack.)
- 3 At the local end, configure the modem:
 - Follow the manufacturer's instructions to set the modem for 9600 baud, autoanswer, dumb mode, command recognition OFF, command echo OFF.
- 4 At the local end, connect NT8D95 cables to
 - J21 on the I/O panel in the rear of the Core or Core/Network Modules
 - the SDI port on the I/O panel in the rear of the Network module
- 5 At the local end, connect NT8D84 cables to
 - the SDI Paddle Board at the Core/Network backplane to the I/O panel in the rear of the Core/Network Module or cPCI Core/Network Module.
- 6 At the local end, connect NT8D95 cables from the I/O panels to a matching connector on the switch box.
 - a. If you are using an A0377992 ABCDE box, connect cables as follows:
 - Connect CPU 0 to connector A.
 - Connect CPU 1 to connector B.
 - Connect the SDI port to connector D (connector C is common).
- 7 At the local end, connect an NT8D95 cable from the switch box to the modem.

- 8** At the local end, connect the cable from the modem to an RJ11 telephone jack. (If a cable is required, connect an NT8D46 cable to the modem and to the RJ11 jack.)
- 9** At the local end, set the switch box as needed to communicate with the CPSI/COM 2 ports:
 - During normal operation, set the switch to the SDI port.
 - For debugging, set the switch to the *active* CPU.
 - For patch downloading, set the switch to the *inactive* CPU.

Figure 60
Modem to a switch box and SDI and CPSI/COM 2 ports (dual-column systems)

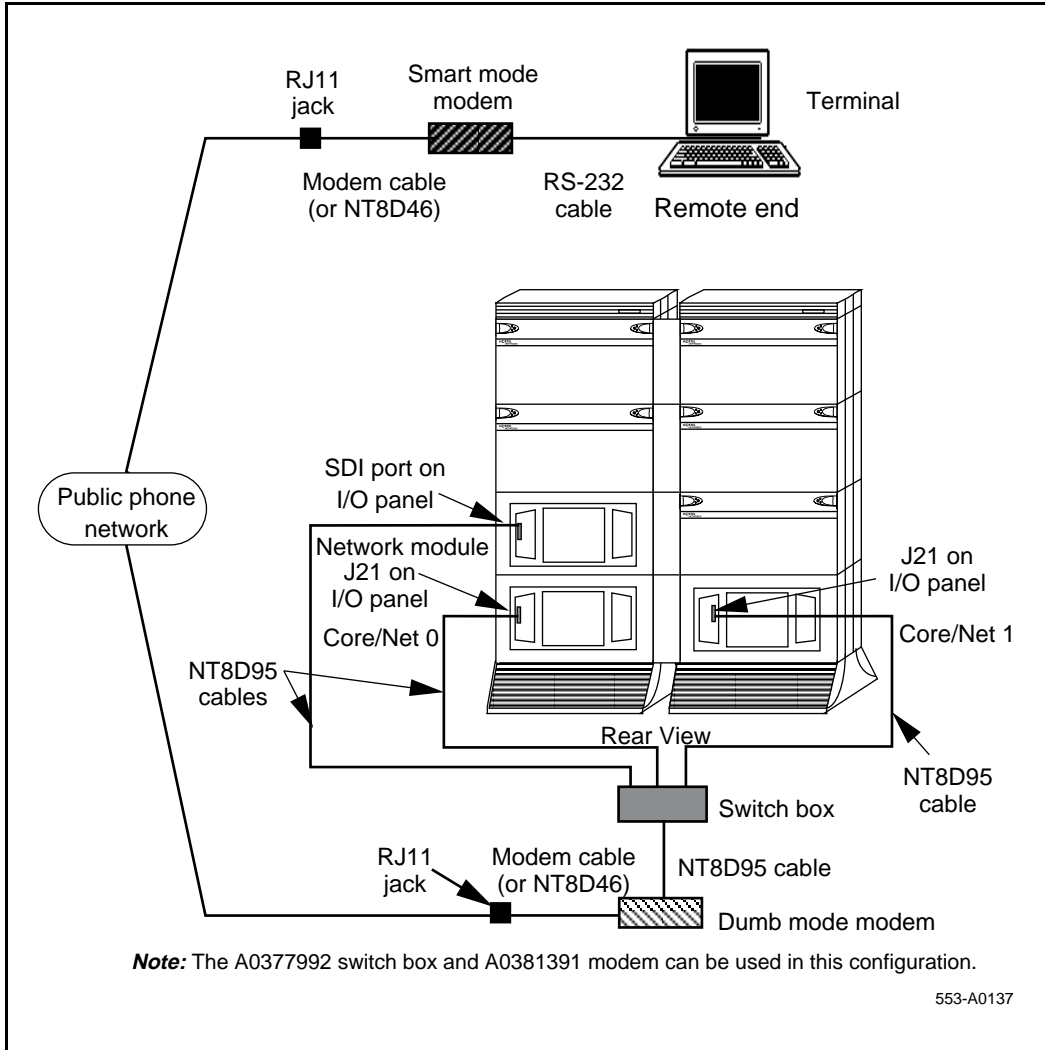
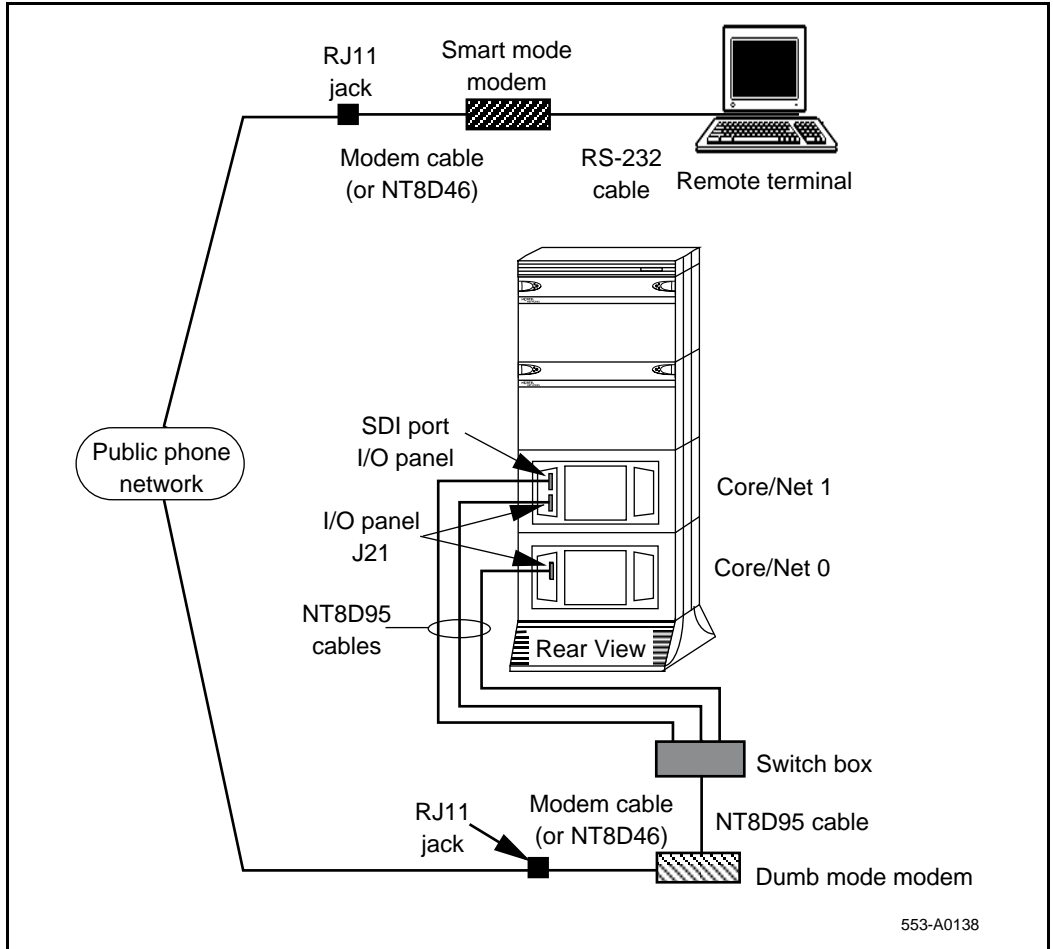

Figure 61
Modem to a switch box and SDI and CPSI/COM 2 ports (single-column systems)



Cabling common equipment

Content list

The following are the topics in this section:

Reference list	123
System Option 61C	124
CNI configuration	125
Cable installation guidelines	126
Cable installation procedures	129
System Option 81C	133
Review Core/Net module placement	133
Review required Core cards	133
Check that the Core cards (front side) are installed	135
Check that the Core Transition cards are installed	137
Cable the Core shelves	139
Cable the Dual Ring Fiber Network	145
Connect the FIJI to FIJI cables	153

Reference list

The following are the references in this section:

- *ISDN PRI: Installation (553-2901-201)*

Note: This procedure does not apply to the Option 51C system.

Use the following guidelines for routing common equipment cables for Options 61C and 81C:

- When routing CNI to 3PE cables, store any excess cable length near the associated Network Module. Do not store excess cable in the Core/Net Module.
- When routing DIGS to intergroup cables, store excess length near the InterGroup Module.

Because the cable troughs and spaces on the sides of a module are within the EMI shielding of the system, unshielded cables can be routed in those areas. As space permits, common equipment cables can be routed:

- horizontally in the cable troughs at the front, rear, and sides of the module

Note: In a DC-powered module, because there is no MPDU, there is room to route cables horizontally from front to rear on the left side (front view) of the module.

- vertically on the sides of the module



CAUTION
System Failure

Cables must be routed as perpendicular as possible to any nearby power cables. Avoid routing cables near power cables if alternate routing is available. (At the rear of the module, cables routed between the I/O panel and the rear cover can be parallel to the power cables because the panel provides EMI shielding.)

System Option 61C

Option 61C is a dual CPU system with standby processing capability, fully redundant memory, and a full network group. Two Core/Net Modules and one IPE Module are required. Additional IPE Modules, PE Modules, RPE Modules, and application modules can be used.

Figure 62 on page 125 shows a basic configuration.

Figure 62
Option 61C dual CPU, full network group

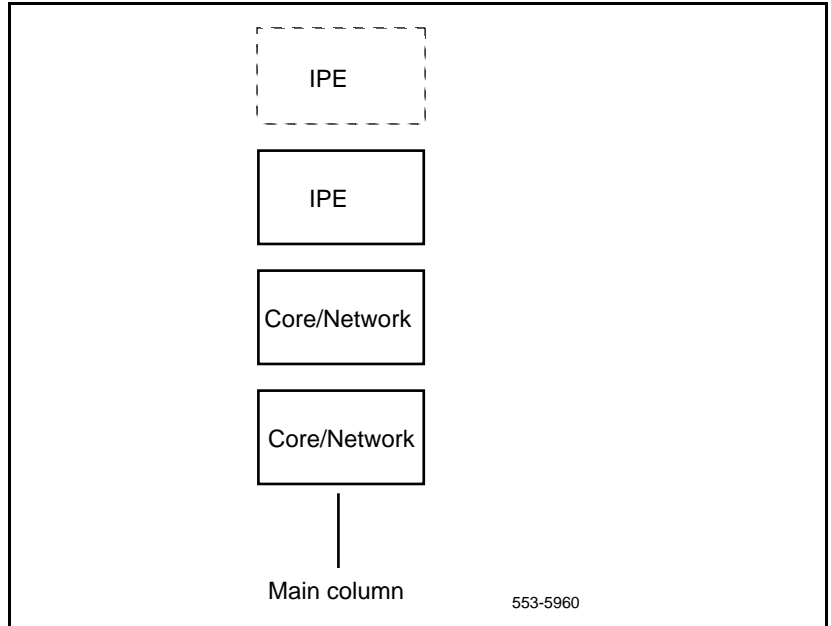

CNI configuration

In the NT5D21 Core/Net Module, port 0 on the NT6D65 Core to Network Interface (CNI) Card in slot 12 must be configured as “group 0.” Communication between the CNI and 3PE cards for group 0 is accomplished through the backplane; no cable is required.

Since only one network group is supported in Option 61C, only one CNI card is required. The CNI card must be installed in slot 12 in the Core/Net Module, and Port 0 is dedicated to “group 0.”

Cable installation guidelines

Core/Net module backplanes, like all circuit boards, have a primary side and a secondary side. The primary side, which faces the front of the module, contains the primary shrouds, which provide mechanical guidance for the pins of the card edge connectors. The secondary side of the backplane, which faces the rear of the module, contains the secondary shrouds, which provide mechanical guidance for cable connectors.

The columns of secondary backplane shrouds are designated 18 through 12 from left to right (facing the rear of the backplane). This numbering matches the card slots in the front of the module. The connector rows of secondary backplane shrouds are designated A through F from top to bottom.

Before you connect cables to the backplane, visually inspect the backplane shroud connectors to make sure there are no bent pins. To connect cables:

- 1 Orient the cable connector so the strain relief paddle is to the right.
- 2 Partially insert the cable connector so its guides mate to the corresponding backplane connector.
- 3 Apply a small amount of pressure to push the cable connector straight into the backplane connector. You will feel a detent click when the connector seats.



CAUTION

Damage to Equipment

Pins may be bent or broken if you try to insert the cable connector at an angle. Do not push the connector in any further after you hear the detent click.

Using the cable extraction tool

To disconnect cables from the Core/Net Module backplane, you will be required to use the P0741489 Extraction Tool provided, located in the rear of the module (behind the I/O safety panel).

**CAUTION****Damage to Equipment**

You must use the extraction tool to disconnect cables from the backplane in NT5D21 Core/Net Modules to avoid bending or breaking backplane pins. Do not improvise with common hand tools.

**CAUTION****Damage to Equipment**

You must use the P0741489 Extraction Tool to disconnect cables from the backplane shrouds in NT9D11 Core/Network Modules.

Follow the procedure below to avoid bending or breaking pins when removing cable connectors from the backplane shrouds. Do not insert the extraction tool unless the cable connector is locked into the shroud. Do not force the extraction tool deeper than the detent on the cable connector.

Follow the procedure below to remove cable connectors from the backplane. Use extreme caution to avoid bending or breaking backplane pins. Do not insert the extraction tool unless the cable connector is locked into the securing clip; a gentle tug on the cable will allow you to determine whether or not the connector is secured. Do not force the extraction tool deeper than the tab on side of the cable connector hood.

- 1 Grasp the cable connector by the strain relief tab.
- 2 Center the long flat edge at the angled end of the tool between the cable connector hood and the securing clip.

Note: If the straight end of the tool is notched, use that end if the connector can be accessed straight-on. If you must approach the connector from any angle at all, use the angled end.

- 3 Gently insert the extraction tool and gradually apply pressure in the direction directly toward the backplane while gently pulling the cable away from the backplane. A gentle side-to-side rocking motion may be used on the cable if needed.



CAUTION

Damage to Equipment

Do not pry the against the connector with the extraction tool. Simply inserting the tool between the connector and the securing clip is sufficient to unlock the connector. Prying may cause damage to the connector or the backplane pins.

- 4 Stop applying pressure as soon as the cable connector comes loose from the backplane.
- 5 Slowly remove the extraction tool and the cable connector.

Cable installation procedures

A P0738866 label kit is included in all Option 61C packages. The kit is included in all packages because the preprinted labels may be useful. Use of the labels is optional.

- 1 Connect network half-group 0 in Core/Net 0 to half-group 1 in Core/Net 1:
 - Cable the D connectors (on the rear of the backplane) together with an NT8D99AB cable.
 - Cable the E connectors (on the rear of the backplane) together with another NT8D99AB cable.
 - Figure 63 on page 129 shows the D and E connectors on the backplane of the NT5D21 Core/Net Module and the cables required.

Figure 63
NT5D21 Core/Net Module (rear view)—location of D and E connectors

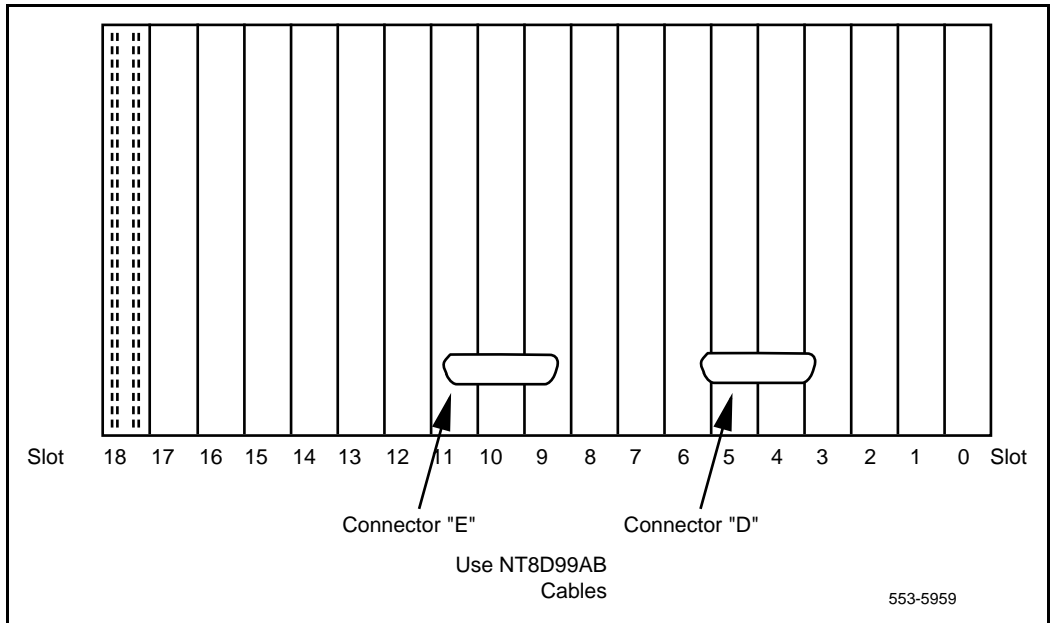

- 2 At the rear of the module, remove the left I/O panels. Verify that the following cables are installed in both Core/Net Modules (see Figure 64 on page 130):
 - An NT7D89 RS-232 cable (CP to I/O panel) should be connected to backplane connector position 15D and to ports J21 and J25 on the I/O panel. Check the labeling on the cables to identify the J21 and J25 connectors.
 - An NT7D90 Ethernet cable should be connected to backplane connector position 17F and to port J28 on the I/O panel.

Figure 64
NT5D21 Core/Net Module (rear)—pre-installed backplane connections

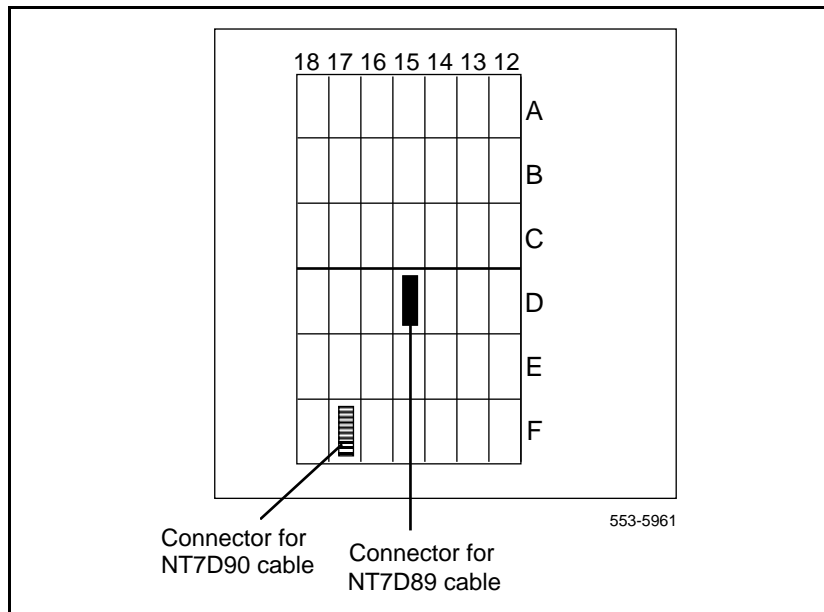

- 3 On the faceplates of the 3PE cards in the Core/Net Modules:
 - connect an NT8D80BZ cable from J4 in Core/Net 0 to J4 in Core/Net 1
 - connect another NT8D80BZ cable from J3 in Core/Net 0 to J3 in Core/Net 1.
- 4 In the rear of the Core/Net Modules, connect the cables between Core/Net 0 and Core/Net 1 (see Figure 65 on page 131):

Note 1: The following cables may already be connected in one of the modules. If so, leave them connected and attach the loose end.

Note 2: The cables must be routed as perpendicular as possible to nearby power cables.

- Connect the NTND13 IOP to IOP SCSI Cable from backplane connector position 17A in Core/Net 0 to backplane connector position 17A in Core/Net 1 (see Figure 65 on page 131).
- Connect one NTND11 CP to CP Cable from backplane connector position 15C in Core/Net 0 to backplane connector position 15C in Core/Net 1 (see Figure 65 on page 131).
- Connect another NTND11 cable from backplane connector position 15A in Core/Net 0 to backplane connector position 15A in Core/Net 1 (see Figure 65 on page 131).
- Reinstall the left I/O panels in both Core/Net Modules. Use and tighten all eight screws.

Figure 65
NT5D21 Core/Net Module (rear)—connections for IOP/CMDU to IOP/CMDU and CP to CP cables

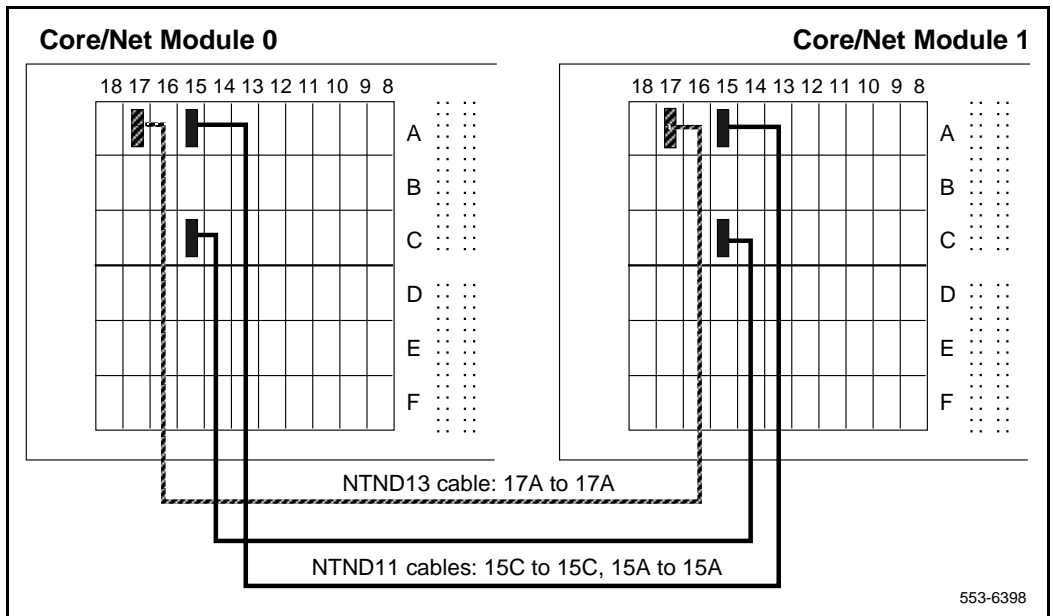

- 5 Interconnect the clock controller cards in both Core/Net Modules (see Figure 66 on page 132).
 - Connect an NT8D75 (BC or BD length as needed) from the faceplate connector on the clock controller card in Core/Net 0 to the faceplate connector on the clock controller card in Core/Net 1.

Figure 66
NT5D21 Core/Net Module (front)—clock controller card connections

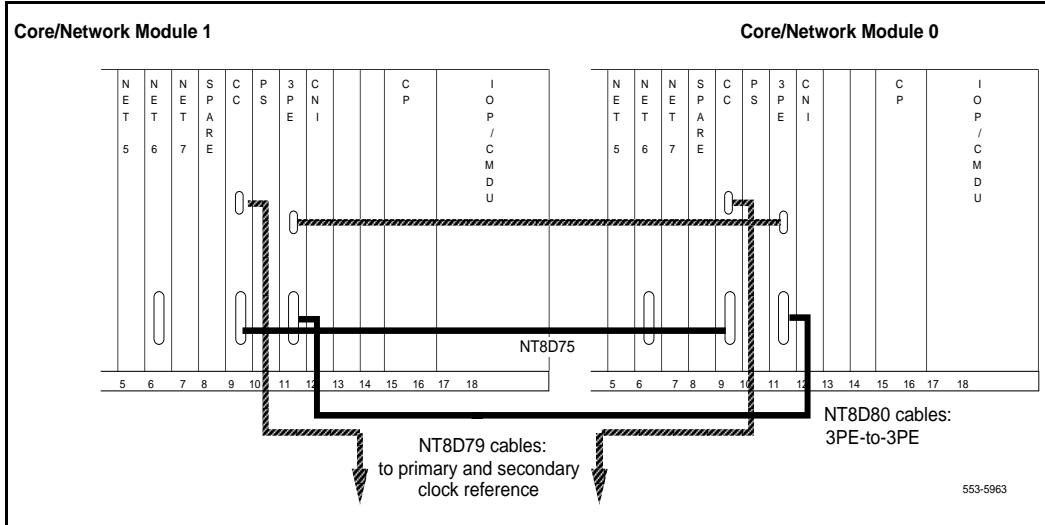

- 6 If PRI/DTI cards are equipped in the Core/Net Modules, connect the faceplate cables.

Note: For detailed instructions on PRI/DTI connections, see *ISDN PRI: Installation* (553-2901-201).

- Connect a QCAD133 cable from connector J4 on the card to the I/O panel.
- Connect an NT8D85 cable from connector J3 on the card to the selected QPC414 Network Card.
- If needed, connect two NT8D79 cables from connectors J1 and J2 on the card to the respective clock controller cards in each Core/Net Module.

System Option 81C

The Core/Net modules contain two distinct sets of circuit cards: Core cards and Network cards. See Figure 67 on page 134. This chapter contains instructions on how to configure the Core side of the CP PII Core/Net modules. To configure the Network side of the Core/Net modules, follow the instructions in “Cabling network modules and loops” on page 157.

Review Core/Net module placement

Core/Net modules are installed side by side on top of separate pedestals, for power and cooling redundancy. Core/Net 1 is always on the left. Core/Net 0 is always on the right. See Figure 67 on page 134.

Switches on the side of the System Utility Transition card identify the Core/Net modules as Core 0 or Core 1.

Review required Core cards

All Core cards are installed in the factory. See Table 13 on page 135 for the Core card requirements for each Core/Net module.

Figure 67
Side by side placement of CP PII Core/Net modules

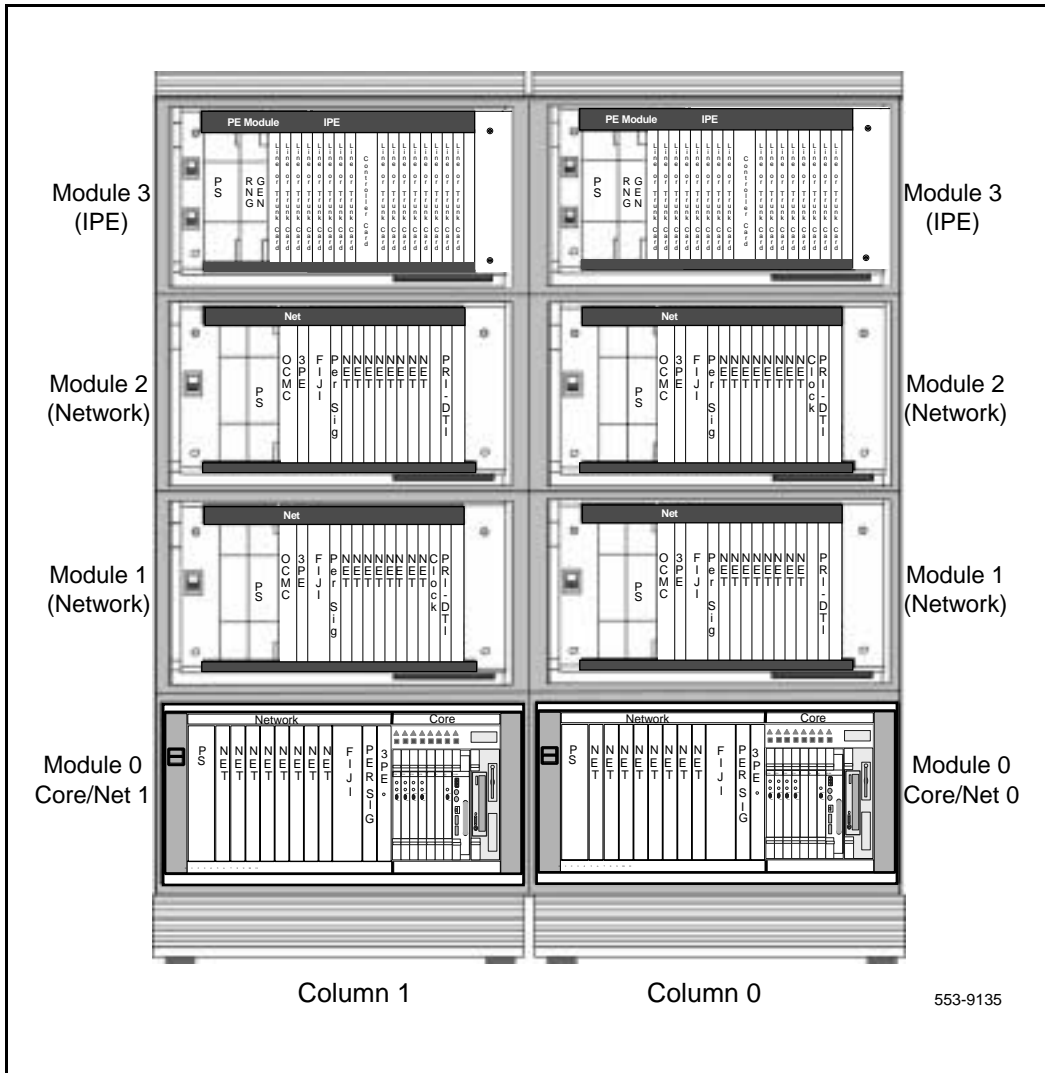

Refer to “Universal Equipment Modules” on page 22 for module and card descriptions.

Table 13
Required Core cards (minimum per Core/Net module)

Card part number	Description	Number required per Core/Net module	Backplane side
NT4N65AB	cCNI: cPCI Core Network Interface Card	1 to 4 ¹	front
NT4N66AB	cCNI Transition card ² : cPCI Core Network Interface Transition Card	4	back
NT4N67AA	System Utility Card	1	front
NT4N68AA	System Utility Transition Card ²	1	back
A0810496	CP PII Call Processor Card (128MB memory)	1	front
NT4N43BA	cPCI Multimedia Disk Unit (MMDU)	1	front

Note 1: Each cCNI card supports two Network groups. The number of cCNI cards in each system depends on the number of Network groups installed in the system. See the System Layout plan to determine the number and placement of cCNI cards.

Note 2: Transition cards are factory installed on the back of the he data bus backplane. These cards add functionality and cable connections to the front side cards.

Check that the Core cards (front side) are installed

All Core cards are factory installed. The Core cards (front side) are:

- **NT4N65AB cPCI Core Network Interface (cCNI) cards:** Each system contains between one and four NT4N65 cCNI cards per Core/Net Module. The cCNI cards are located in slots c9-c12. If not already installed, install a P0906308 cPCI Card Slot Filler Panel to cover any of slots, c10 - c 12, which do not contain cCNIs.
- Slots c13 and c14 are left empty. If not already installed, install a P0906308 cPCI Card Slot Filler Panel in each slot.
- **NT4N67AA System Utility (Sys Util) card** is located in slot c15.

- **A0810496 Call Processor PII (CP PII)** is located in the slot marked CP.
- **NT4N43AA cPCI Multi-Media Disk Unit (MMDU)** is located in the extreme right hand slot next to the CP PII card. The MMDU contains the Hard drive, floppy drive and CD-ROM drive.

Figure 68
Core card placement in the NT4N41 Core/Net Module (front)

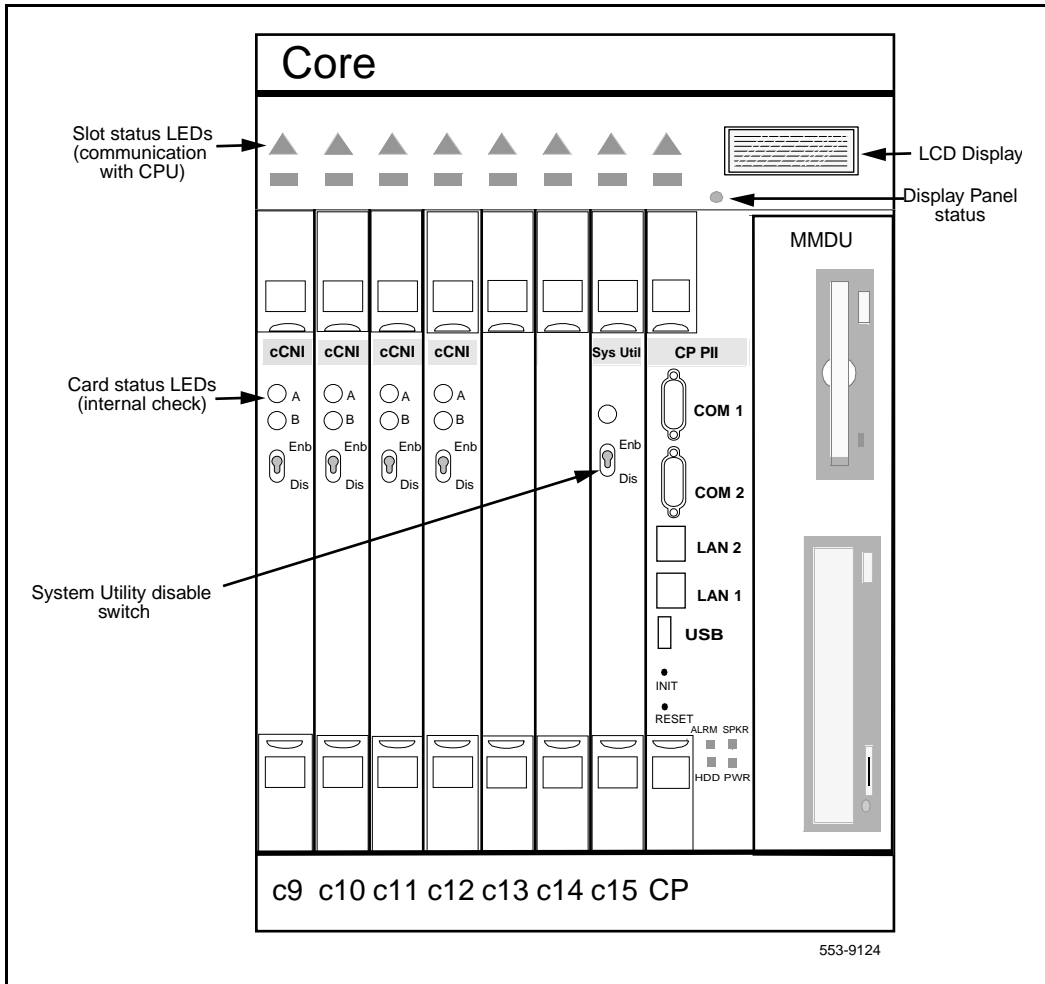

Figure 68 on page 136 shows Core card (front side) placement.

If the Core cards are not installed, see Figure 68 on page 136 and add or replace cards.

Check that the Core Transition cards are installed

Transition cards are factory installed on the back side of the Core backplane. See Figure 69 on page 138. These cards add functionality and cable connections to the front side cards.

There are two types of Transition cards:

- **cCNI Transition cards:** these cards provide the cCNI to 3PE cable connections. Four cCNI Transition cards are installed directly behind the cCNI card slots on the back side of each Core backplane, regardless of the number of cCNI main cards.
- **Sys Util Transition cards:** this card provides data, security and system monitoring connections for the Core shelf. One card is installed directly behind the System Utility card in each Core/Net module.

Figure 69
Transition card layout (back side of the Core backplane)

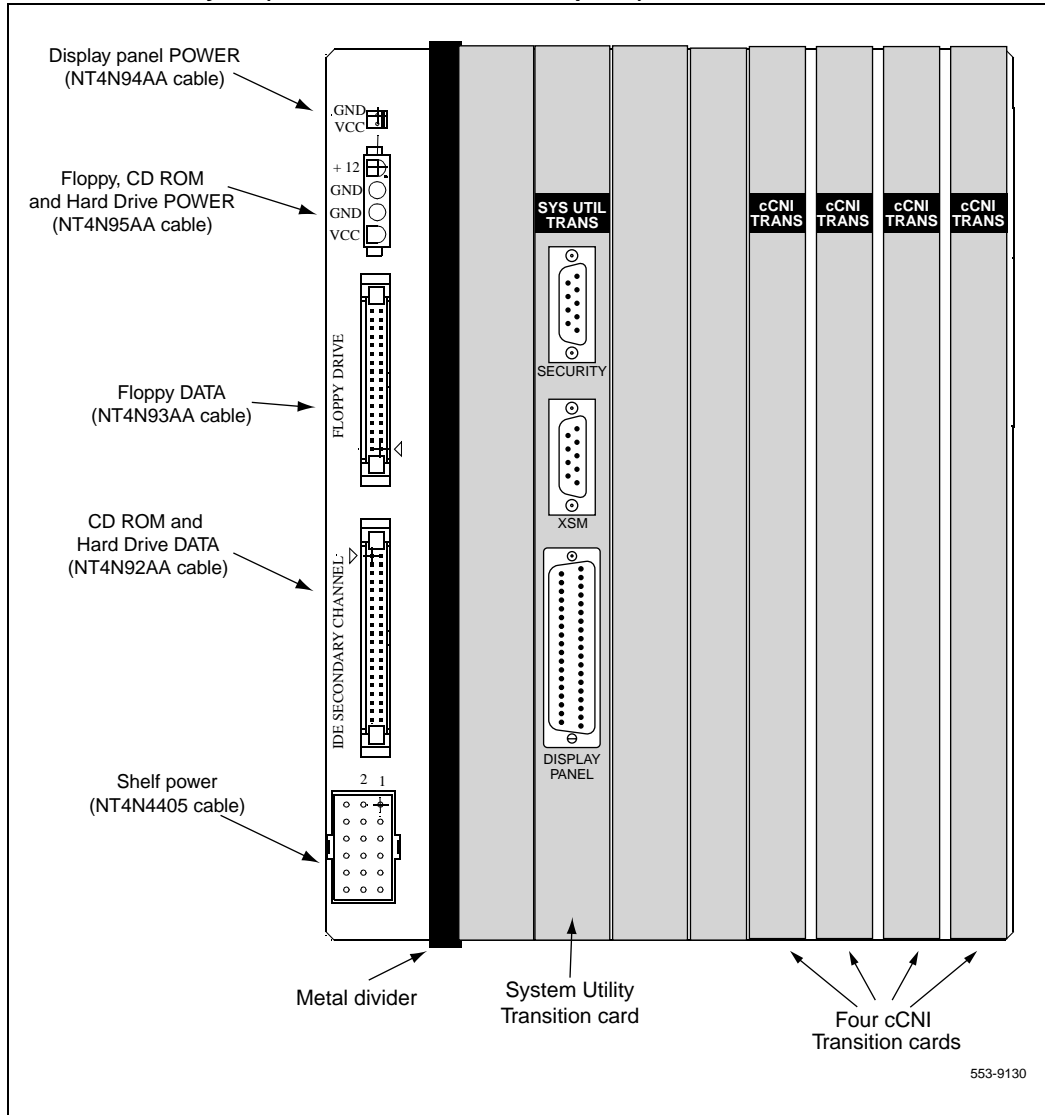

Cable the Core shelves

This section describes installation of the *internal* Core cables. Cables for Core to non-Core modules are described in subsequent sections.

Required Core cables

Table 14 on page 139 lists field installed cables. Cables in Table 15 on page 139 are factory installed.

Table 14
Field installed Core cables (internal)

Cable part number	Description	Number required per system
NT4N88AA	COM 1 (DTE/terminal)	2
NT4N88BA	COM 2 (DCE/modem)	2
NT4N90AA	Ethernet (CP PII card to I/O panel)	2
NTRC17AA	Crossover Ethernet cable (Core to Core)	2
customer supplied	Standard Ethernet cable (Core to LAN hub)	2

Table 15
Factory installed Core cables (internal)

Cable part number	Description	Number required per system
NT4N4405	Shelf Power: Net backplane to Core backplane	2
NT4N89AA	System Utility card to XSM	2
NT4N91AA	LED/LCD Data	2
NT4N92AA	CD-ROM/HDD Data	2
NT4N93AA	FDD Data	2
NT4N94AA	LED/LCD Power	2
NT4N95AA	Core/Net FDD/HDD/CD ROM Power	2

Figure 70
Core/Net cable connections (top view)

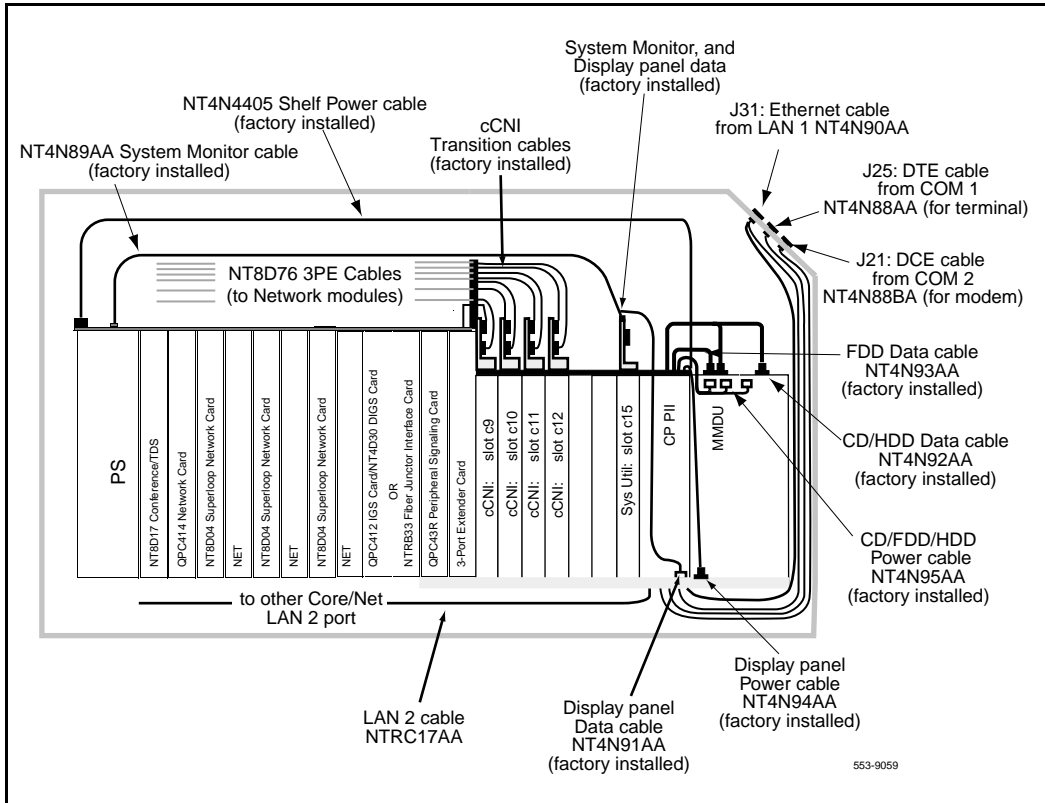

Install the CP PII to I/O panel cables

Connect the cables from the CP PII card faceplate to the I/O panel on the back of the Core/Net modules:

- COM 1 is used to connect a terminal.
- COM 2 is used to connect a modem.
- LAN 1 is used to connect the system to a LAN hub.
- LAN 2 is used to connect Core 0 to Core 1 for system redundancy.

Figure 70 on page 140 displays the COM and LAN cable connections.

**CAUTION****Loss of Data**

Label all cables on both ends before installation. Labels help ensure that the cables are properly routed and connected. Cable labels also help installers to troubleshoot problems and replace equipment.

- 1 Connect **COM1** on the CP PII faceplate to **J25** on the I/O panel with cable **NT4N88AA**.
- 2 Connect **COM2** on the CP PII faceplate to **J21** on the back of the I/O panel with cable **NT4N88BA**.
- 3 Connect the **Dual Ethernet Adapter** (RJ45) for I/O Panel (NTRE40AA) to **J31**. Secure the adapter to J31 with the two screws included in the shipment.
- 4 Connect **LAN 1** (Ethernet) on the CP PII faceplate to **J31 (top)** of the I/O panel with cable **NT4N90AA**.
This connection can only be made *after* the Dual Ethernet Adapter is installed (see step 3 above).
Note: If a LAN hub is not used, connect LAN 1 in Core 0 to LAN 1 in Core 1. See Figure 72 on page 144.
- 5 Connect a **crossover Ethernet cable (NTRC17AA)** from the **LAN 2** port in Core 0 to the **LAN 2** port Core 1. This connection is for Core redundancy.
Note: To ensure EMI shielding, route the cable along the front of the card cage and through the sides of the Core/Net modules.
- 6 Repeat steps 1 through 4 in the second Core/Net module.

Figure 71
CP PII to I/O panel connections

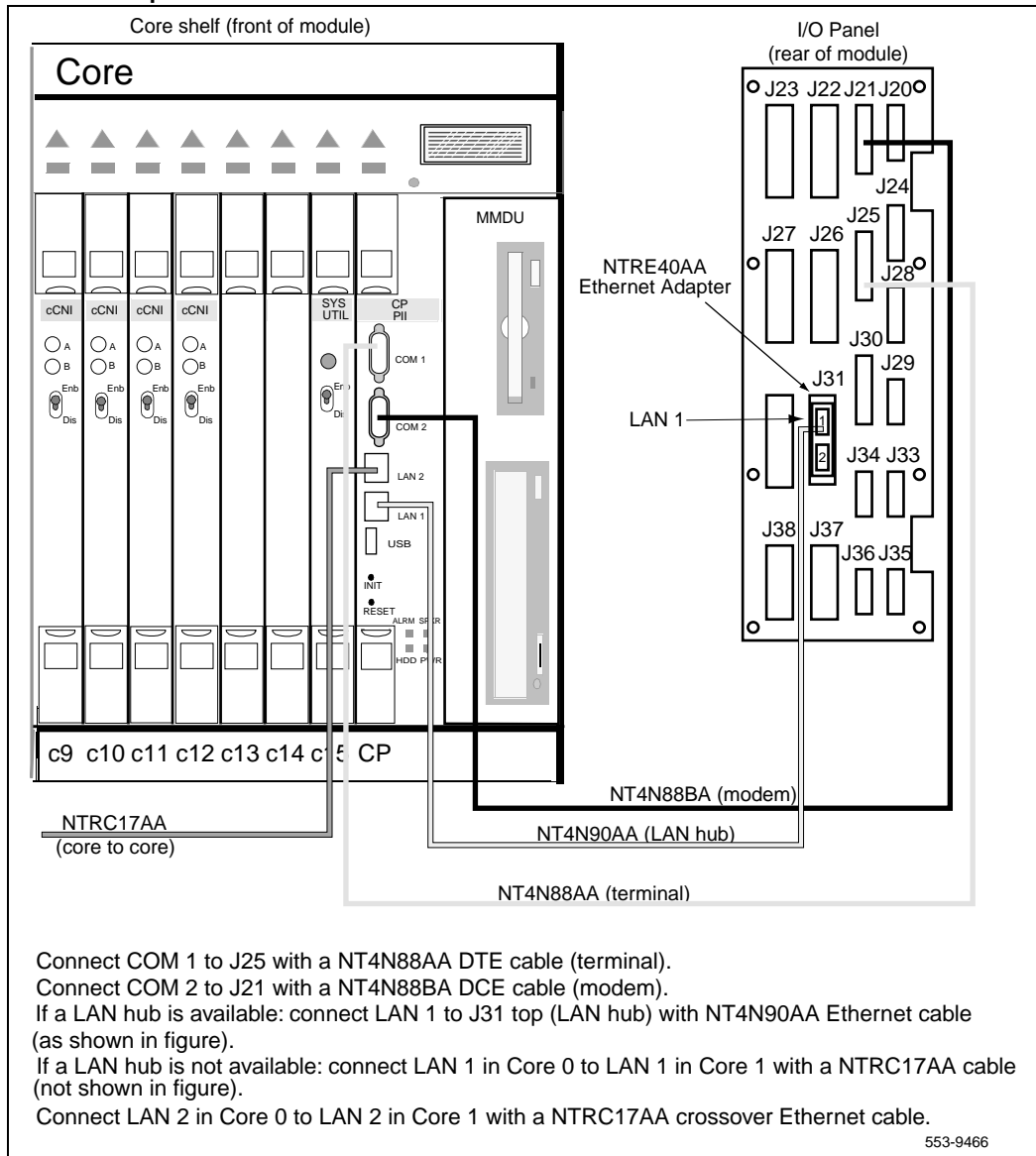

553-9466

Connect the Core modules to a local area network

Connect each Core/Net module to a local area network (LAN). This connection provides a communication channel for LAN based administration tools such as MAT. This connection also supplies additional redundancy capabilities. See Figure 72 on page 144.

Note 1: If a LAN is not available, connect the second NTRC17AA crossover Ethernet cable (included in the basic package) between the J31 ports in Core/Net 0 and Core/Net 1.

Note 2: The Core/Net I/O panel cables must be installed as described on "Install the CP PII to I/O panel cables" on page 140 before the Ethernet connections can be completed.

- 1 Label both sides of two *customer supplied* Ethernet cables.
- 2 Connect an Ethernet cable from J31 (top) on the Core/Net 0 I/O panel to the LAN hub.
- 3 Connect a second Ethernet cable from J31 (top) on the Core/Net 1 I/O panel to the LAN hub.

Figure 72
Options for LAN 1 connections

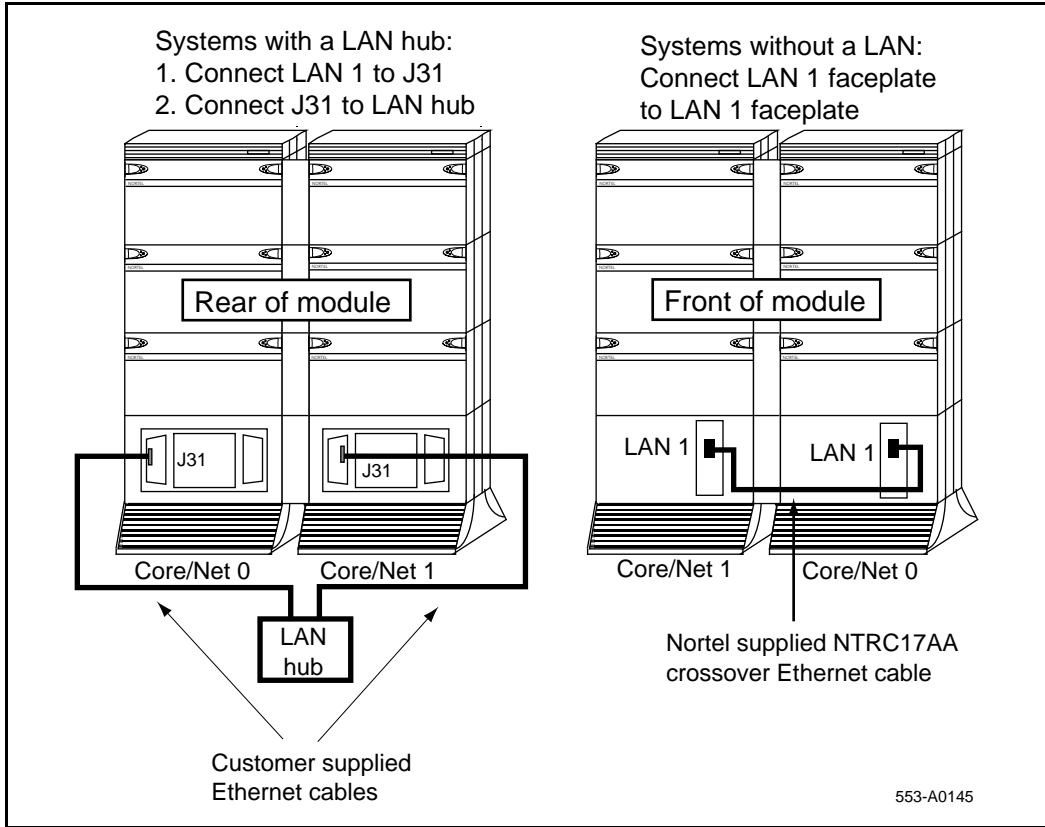

553-A0145

Cable the Dual Ring Fiber Network

The FIJI cards in the Network modules are connected to form a Dual Ring Fiber Network. This allows calls to be routed between Network groups.

The Fiber Network consists of two separate rings: one ring connects all the Network shelf 0's while the second ring connects all the Network shelf 1's (Figure 73 on page 146). Four steps are required to configure the Fiber Network:

- “Install the shelf 0 fiber optic ring (ascending)” on page 151.
- “Install the shelf 1 fiber optic ring (descending)” on page 152.
- “Connect the FIJI to FIJI cables” on page 153
- “Configure the Clock Controllers” on page 154

Figure 73
Dual Ring Fiber Network

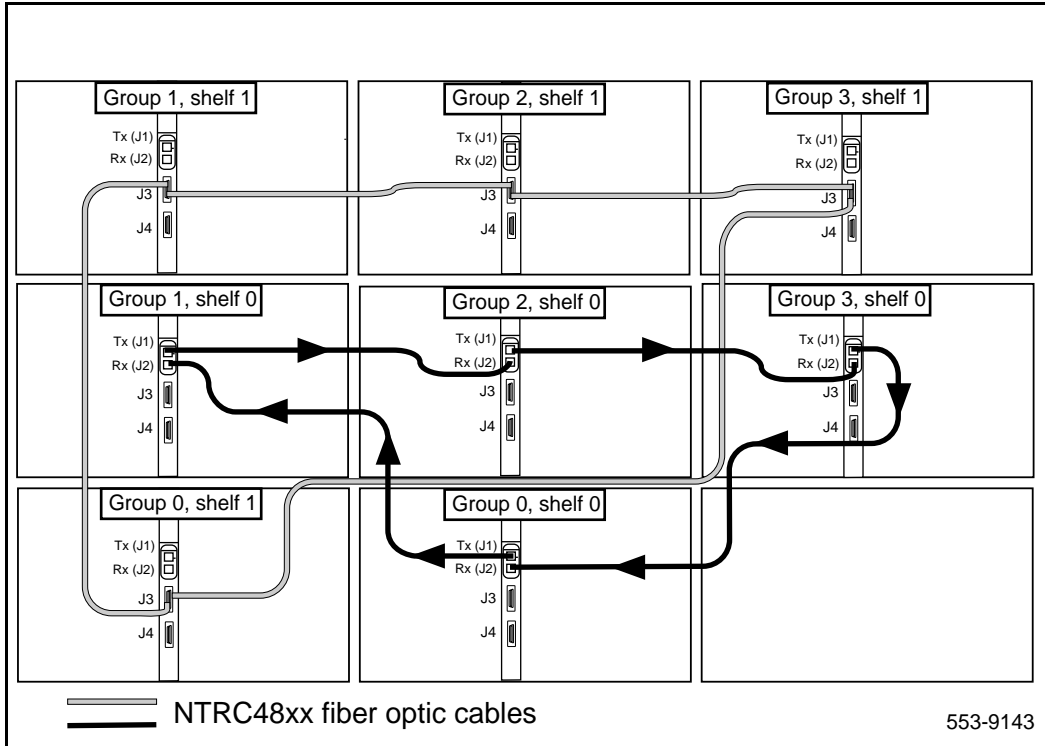

Required cards

The number of circuit cards required by each system depends on system configuration.

Table 16
Fiber Network required cards

Quantity	Part number	Description
1 per Network module	NTRB33	Fiber Junctor Interface (FIJI) card
1 per Network module, as needed	NTRE39	Optical Cable Management Card (OCMC)
8 per system (4 per Core), as needed	NT4N65AA	compact Core Network Interface (cCNI-3) cards
2 per system	QPC471*	Clock Controller cards
2 per system	QPC775**	Clock Controller cards
2 per system	NTRB53	Global Clock Controller cards
<p>* Systems installed in the United States. **Systems installed outside the United States.</p> <p>Note: Either Clock Controller can be installed, but QPC471 and QPC775 Clock cards cannot be combined in one system.</p>		

Required cables

Cable lengths will vary depending on system configuration.

Table 17
Required cables

Cable type	Quantity	Part number	Description
Fiber Ring cable	1 per FIJI card	NTRC48AB	6 ft. fiber optic cable
		NTRC48BB	10 ft. fiber optic cable
		NTRC48CB	12 ft. fiber optic cable
		NTRC48DA	14 ft. fiber optic cable
		NTRC48EA	19 ft. fiber optic cable
		NTRC48FA	26 ft. fiber optic cable
		NTRC48GA	32 ft. fiber optic cable
		NTRC48HA	50 ft. fiber optic cable
Clock to FIJI	2 per system	NTRC46AB	4 ft.-13.5 ft.*
		NTRC46BB	5.5 ft. - 8 ft.*
		NTRC46CB	22 ft.-22 ft.*
Clock to Clock	1 per system	NTRC49AA	6 ft.
		NTRC49BA	20 ft.
FIJI to FIJI Sync	1 per network group	NTRC47AA	5 ft.
* indicates the lengths of the two "Y" terminations.			

FIJI card description

Fiber Network is enabled by the installation of one NTRB33 Fiber Junctor Interface (FIJI) card in each Core/Net or Network module. FIJI cards require two slots; they are installed in slots 2 and 3 of each Network module, or in slots 8 and 9 of each Core/Net module. The LCD display shows the Network group and shelf. If an error occurs, this window displays an Alarm code.

Figure 74
FIJI card faceplate

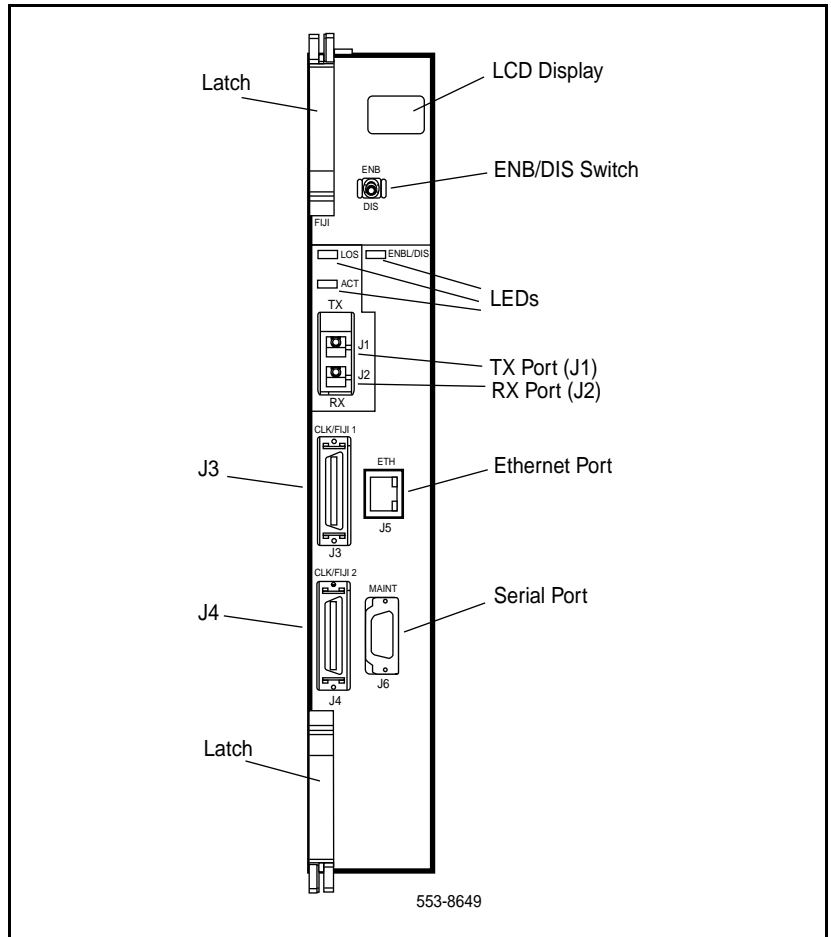

Optical Cable Management Card (OCMC)

Because fiber optic cables are easily damaged if bent, the NTRE39 Optical Cable Management Card (OCMC) is installed in Network modules to store and protect excess cable length. The OCMC card ensures that the fiber cable is not bent beyond a 30 mm bend radius (Figure 75 on page 150).

The OCMC contains no electronic components and is not powered by the backplane. This card is used primarily in upgrades where the intergroup cable distances vary greatly.

OCMC is a single width card installed between the Power supply and slot 1 of a Network module (see Figure 75 on page 150).

Figure 75
OCMC: the Optical Cable Management Card

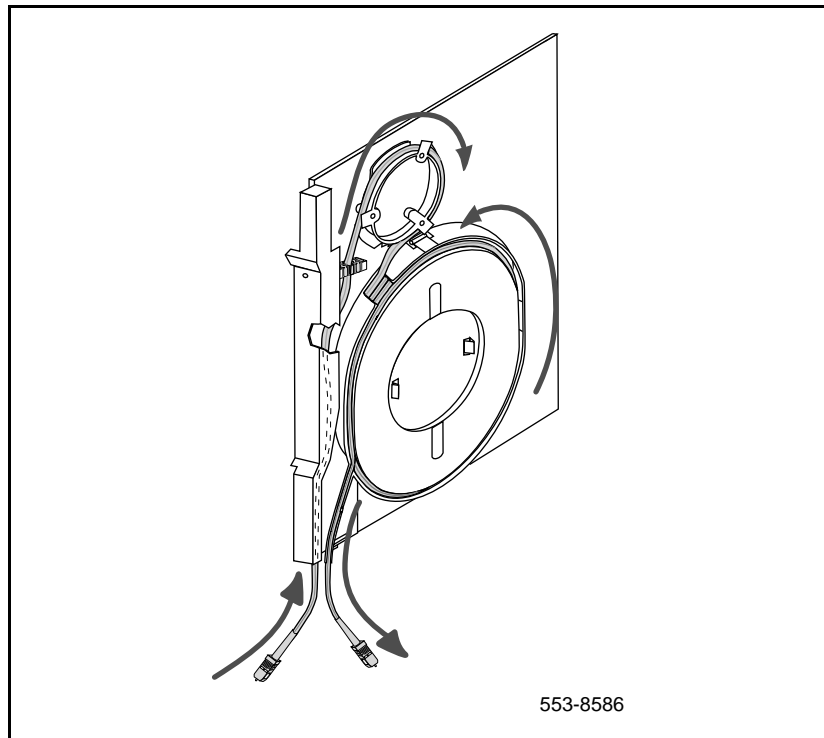

Install the shelf 0 fiber optic ring (ascending)

To create the shelf 0 fiber optic loop, connect the FIJI cards in each Network shelf 0 in *ascending* order (Figure 76 on page 151):

- 1 Start with the Tx (J1) port in group 0, shelf 0.
- 2 Connect a NTRC48xx FIJI Fiber Ring Cable of the appropriate length from the Tx (J1) port of the FIJI card in **Group 0, shelf 0** to the Rx (J2) port of the FIJI card in **Group 1, shelf 0**.
- 3 Connect a NTRC48xx FIJI Fiber Ring Cable of the appropriate length from the Tx (J1) port of the FIJI card in **Group 1, shelf 0** to the Rx (J2) port of the FIJI card in **Group 2, shelf 0**.
- 4 Continue to connect NTRC48xx FIJI Fiber Ring Cables of the appropriate length from the Tx (J1) port to the Rx (J2) port in shelf 0 of each Network group. Connect these cables in **ascending** order of Network groups.
- 5 To complete the ring, connect a final cable from the Tx (J1) port in the **highest number group** back to the Rx (J2) port in **Group 0, shelf 0**.

Figure 76
Shelf 0 fiber optic ring

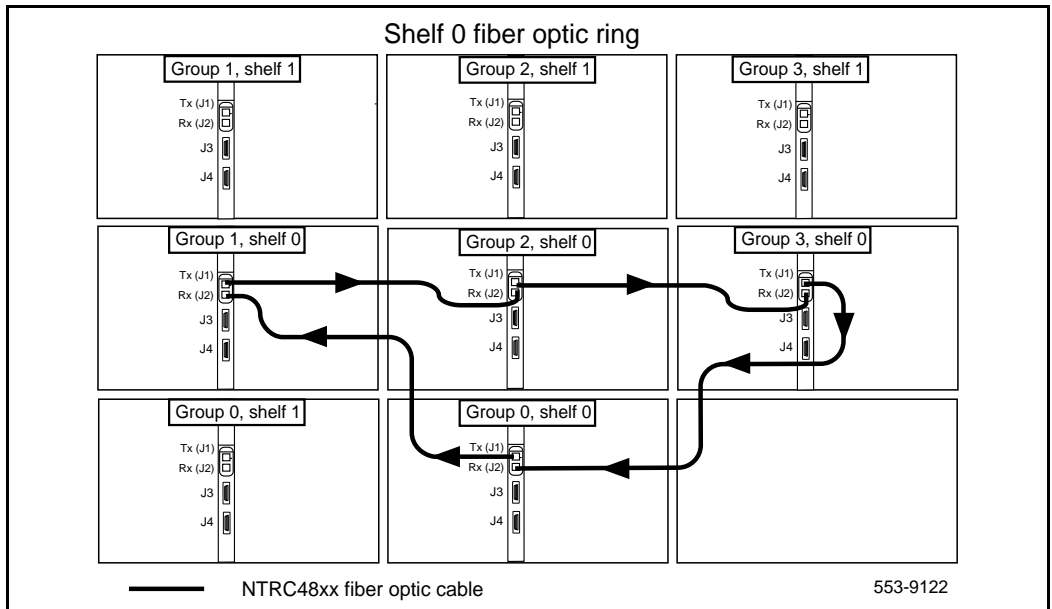

Install the shelf 1 fiber optic ring (descending)

To create the shelf 1 fiber optic loop, connect the FIJI cards in each Network shelf 1 in *descending* order (Figure 77 on page 152).

- 1 Start with the Tx (J1) port in group 0, shelf 1.
- 2 Connect a NTRC48xx FIJI Fiber Ring Cable of the appropriate length from the Tx (J1) port of the FIJI card in **Group 0, shelf 1** to the Rx (J2) port of the FIJI card in the **highest Network group, shelf 1**. This is the longest NTRC48xx cable that came with the shipment.
- 3 Connect a NTRC48xx cable from the Tx (J1) port of the FIJI card from the Tx (J1) port in the **highest Network group, shelf 1** to the Rx (J2) port in the **second highest Network group, shelf 1**.
- 4 Continue to connect NTRC48xx FIJI Fiber Ring Cables of the appropriate length from the Tx (J1) port to the Rx (J2) port in shelf 1 of each Network group. Connect these cables in **descending** order of Network groups.
- 5 To complete the ring, connect a final cable from Tx in **Group 1, shelf 1** to Rx in Group 0, shelf 1.

Figure 77
Shelf 1 fiber optic ring

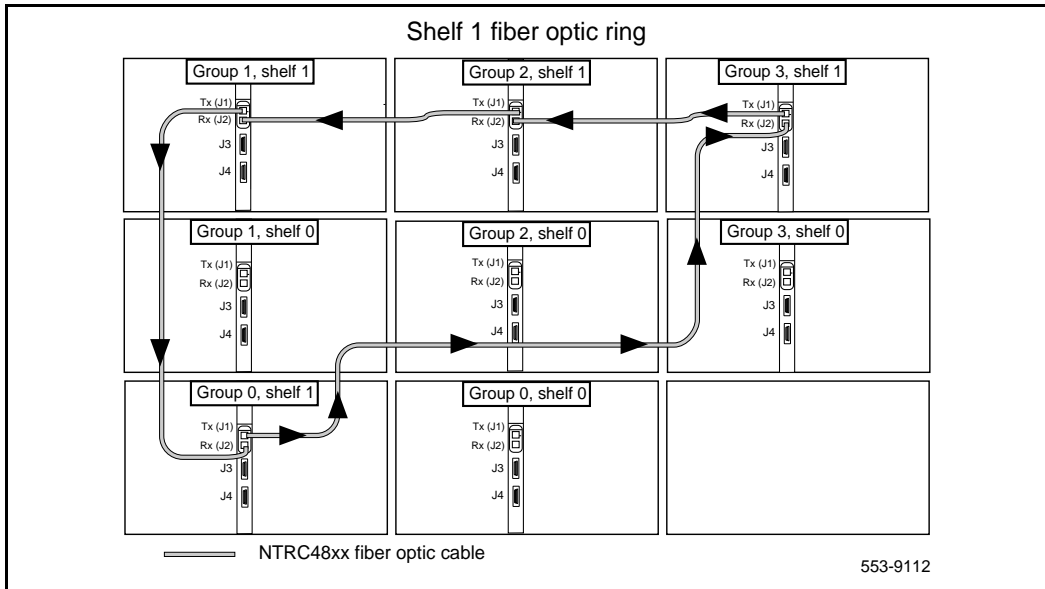

Connect the FIJI to FIJI cables

The FIJI cards in shelf 0 and shelf 1 of each Network group (except group 0) must be directly connected with a NTRC47AA FIJI to FIJI Synch Cable cable.

- 1 Connect a NTRC47AA cable from J4 to J4 of the FIJI cards in each Network group, except group 0 (Figure 78 on page 153).
- 2 **Do NOT connect a cable in group 0.** The FIJI to FIJI connection in group 0 is made as part of the Clock Controller connections described on page 154.

Figure 78
FIJI shelf 0 to FIJI shelf 1 connections

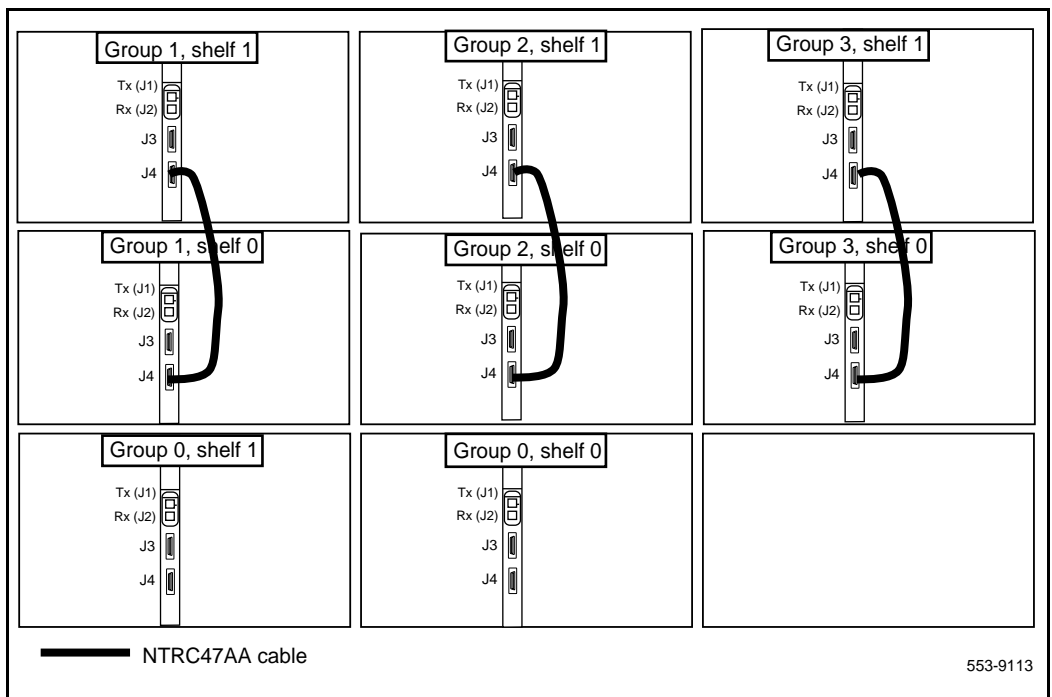

Configure the Clock Controllers

Two Clock Controller cards are required in each system. These cards synchronize Meridian 1 functions.

The Clock Controllers are installed based on the rules listed below.

Figure 79 on page 155 shows the two Clock Controllers installed in a two-column system.

Cards must be installed based on the rules below:

- Two Clock Controller cards are installed in each system. The Clocks are connected to each other and to the FIJI cards in Network group 0.
- The two Clock Controllers must be installed in Slot 13 of any Network module.
- One Clock must be installed in a Network shelf 0. The second Clock Controller must be installed in a Network shelf 1.
- Clock Controllers are installed in different Network groups.
- Clock Controllers are installed in separate columns for power and cooling redundancy.

Connect the Clock Controller cables

Connect the cables to the Clock Controllers as shown in Figure 80 on page 156:

- 1 Connect the Clock to Clock cable:
 - a. Connect P1 of the NTRC49 cable to port J3 of Clock Controller 0.
 - b. Connect P2 of the NTRC49 cable to port J3 of Clock Controller 1.
- 2 Connect the Clock to Clock and Clock to FIJI cables:
 - a. At Clock 0: Connect the “**J1 Clock**” end of a Clock to FIJI cable (NTRC46Ax) to the **J1** end of the Clock to Clock cable.
 - b. At Clock 1: Connect the “**J1 Clock**” end of a second Clock to FIJI cable (NTRC46Ax) to the **J2** end of the Clock to Clock cable.
- 3 Connect the Clock 0 to FIJI cable:
 - a. Connect P1 of the NTRC46 cable from Clock 0 to **J4** of the FIJI card in group 0, **shelf 0**.

- b. Connect P2 of the NTRC46 cable from Clock 0 to **J4** of the FIJI card in group 0, **shelf 1**.
- 4** Connect a Clock 1 to FIJI cable:
- a. Connect P1 of the NTRC46 cable from Clock 1 to **J3** of the FIJI card in group 0, **shelf 0**.
 - b. Connect P2 of the NTRC46 cable from Clock 1 to **J3** of the FIJI card in group 0, **shelf 1**.

Figure 79
Clock Controller placement

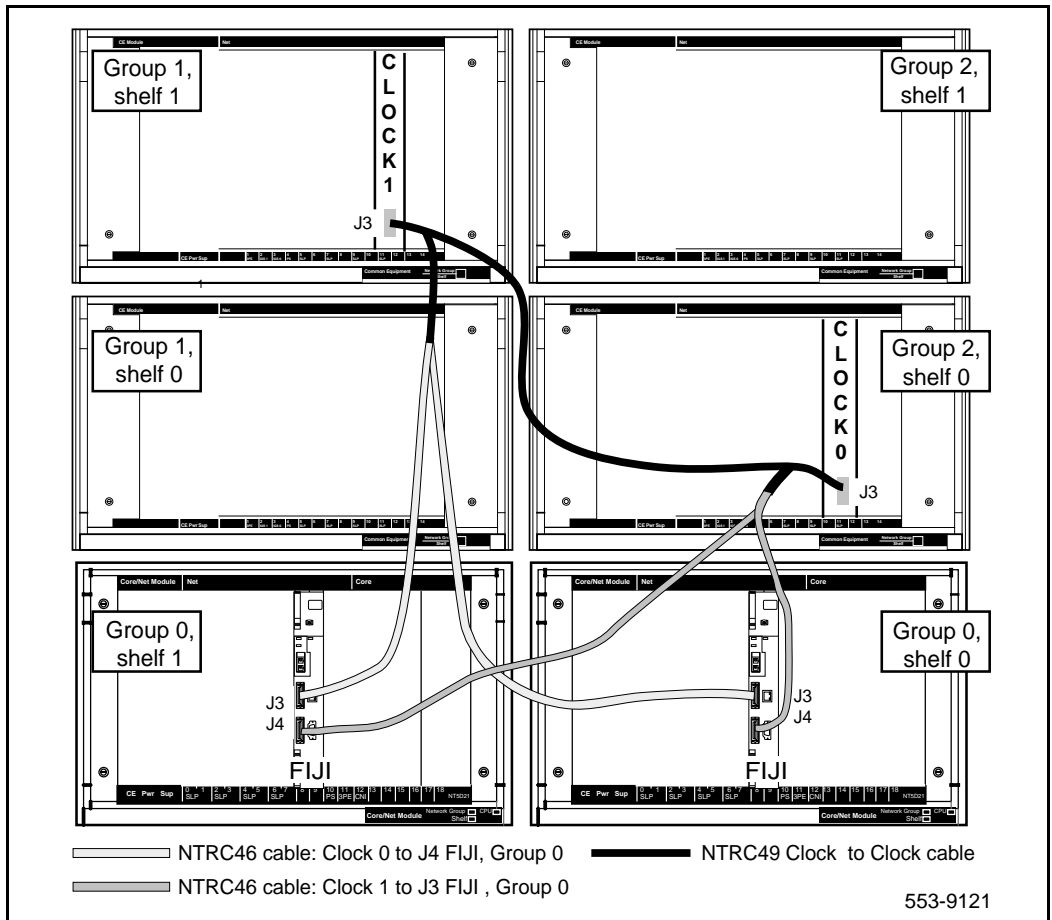
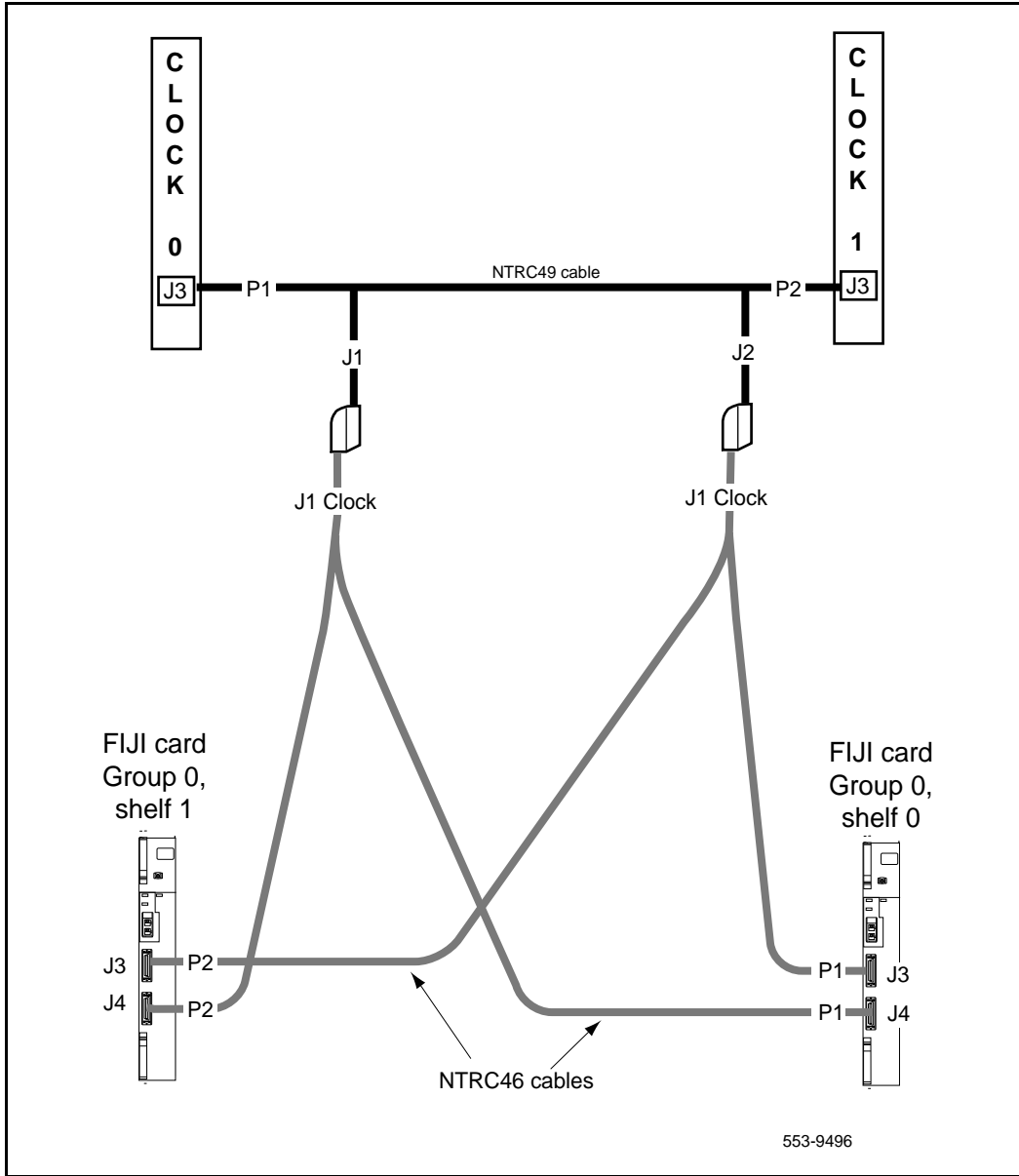

Figure 80
Clock Controller cable configuration



Cabling network modules and loops

Content list

The following are the topics in this section:

Option 81C network module connections	157
Connect network group 0: shelf 0 to shelf 1	157
Connect groups 1 through 7: shelf 0 to shelf 1	160
Connect the Network modules to the Core/Net modules	161
Option 61C and 81C network card connections	169
NT8D04 Superloop Network Card	169
QPC414 Network Card	178

Reference list

The following are the references in this section:

- *Administration* (553-3001-311)

Option 81C network module connections

Each Option 81C system contains between two and eight Network groups. Group 0 is contained in the Core/Net modules. Groups 1 through 7 are contained in the Network modules. Each Network group is comprised of two Network shelves: shelf 0 and shelf 1.

Connect network group 0: shelf 0 to shelf 1

The Core/Net modules contain Network group 0: shelf 0 is in Core/Net 0, shelf 1 is in Core/Net 1.

Shelf 0 must be connected to shelf 1 for Network group 0 to operate correctly. Complete the two steps below:

- 1 "Connect the 3PE faceplates in the Core/Net modules" on page 158.
- 2 "Connect the Core/Net backplanes" on page 159.

Connect the 3PE faceplates in the Core/Net modules

The 3PE cards in the Core/Net modules must be directly connected with an NT8D80 cable. See Figure 81 on page 158. This connection is only made between the group 0 shelves (in the Core/Net modules).

- 1 Connect a NT8D80 cable from the J4 port in the Core/Net 0 3PE card to J4 port in the Core/Net 1 3PE card.
- 2 Connect a second NT8D80 cable from the J3 port in Core/Net 0 to the J3 port in Core/Net 1.

Note: The 3PE cards are located in Core/Net slot 11.

Figure 81
3PE faceplate connection between the Core/Net modules

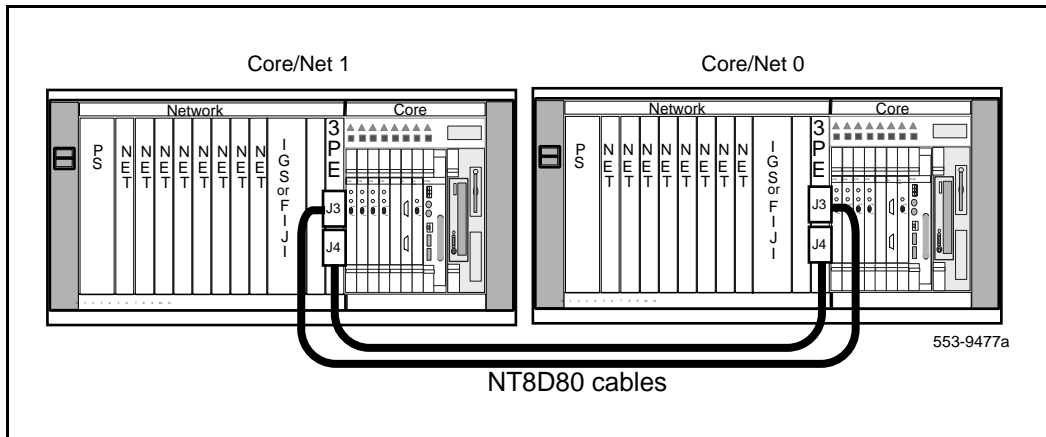

Connect the Core/Net backplanes

In group 0 only, the shelf 0 and shelf 1 backplanes must be connected with two NT8D99AD cables (Core/Net modules only).

- 1 Connect one NT8D99AD cable from the “E” port in Core/Net 0 to the “E” port in Core/Net 1.
- 2 Connect a second NT8D99AD cable from the “D” port in Core/Net 0 to the “D” port in Core/Net 1. See Figure 82 on page 159.

Figure 82
Network group 0: shelf 0 to shelf 1 backplane connections

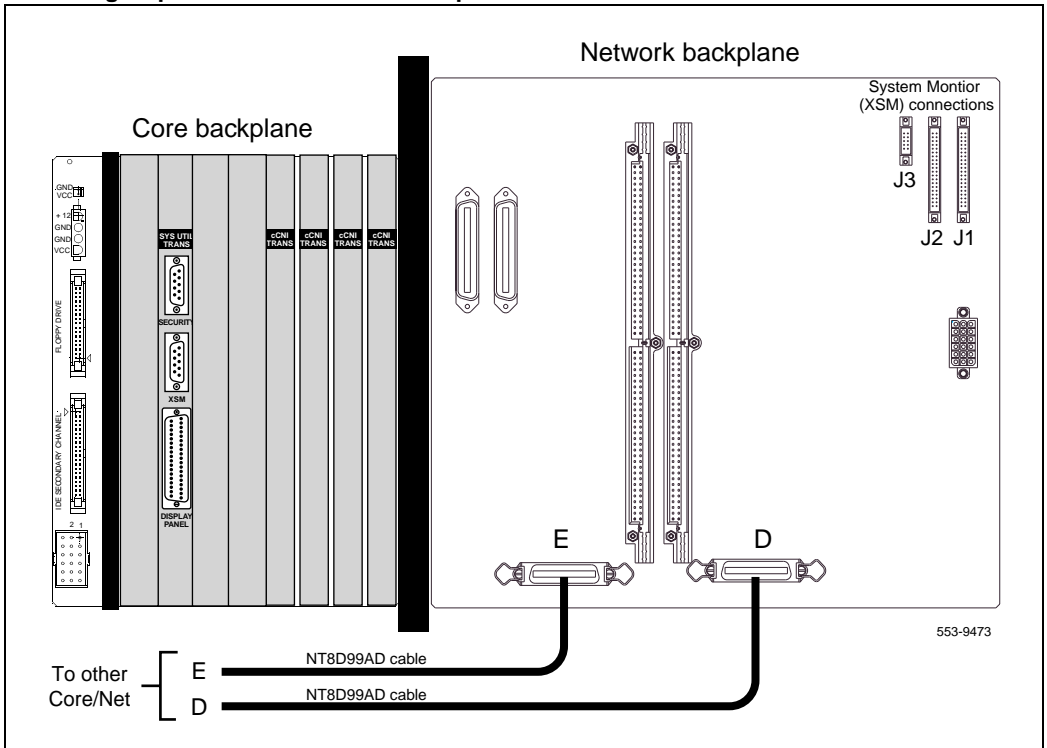

Connect groups 1 through 7: shelf 0 to shelf 1

On the back of each Network module backplane are five connectors: A, B, C, D and E. See Figure 83 on page 161. The connectors from shelf 0 of each Network group 1 through 7 must be connected to the connectors in shelf 1 of the same Network group.

Note: In North American systems, these connections are made in the factory. In shipments outside North America, the Network shelves are shipped separately. These connections must be made in the field

This connection is NOT made for Network group 0 in the Core/Net modules.

- 1 Connect an NT8D99AB cable from the **A** connector in shelf 0 of Network group 1 to the **A** connector in shelf 1 Network group 1.
- 2 Connect the **B** connector in shelf 0 to the **B** connector in shelf 1.
- 3 Connect the **C** connector in shelf 0 to the **C** connector in shelf 1.
- 4 Connect the **D** connector in shelf 0 to the **D** connector in shelf 1.
- 5 Connect the **E** connector in shelf 0 to the **E** connector in shelf 1.
- 6 Connect the A, B, C, D, and E connectors between shelf 0 and shelf 1 for all other Network groups in the system (except group 0)

Note: All connections are made with an NT8D99AB cable.

Figure 83
Network shelf 0 to shelf 1 backplane connections (groups 1 through 7)

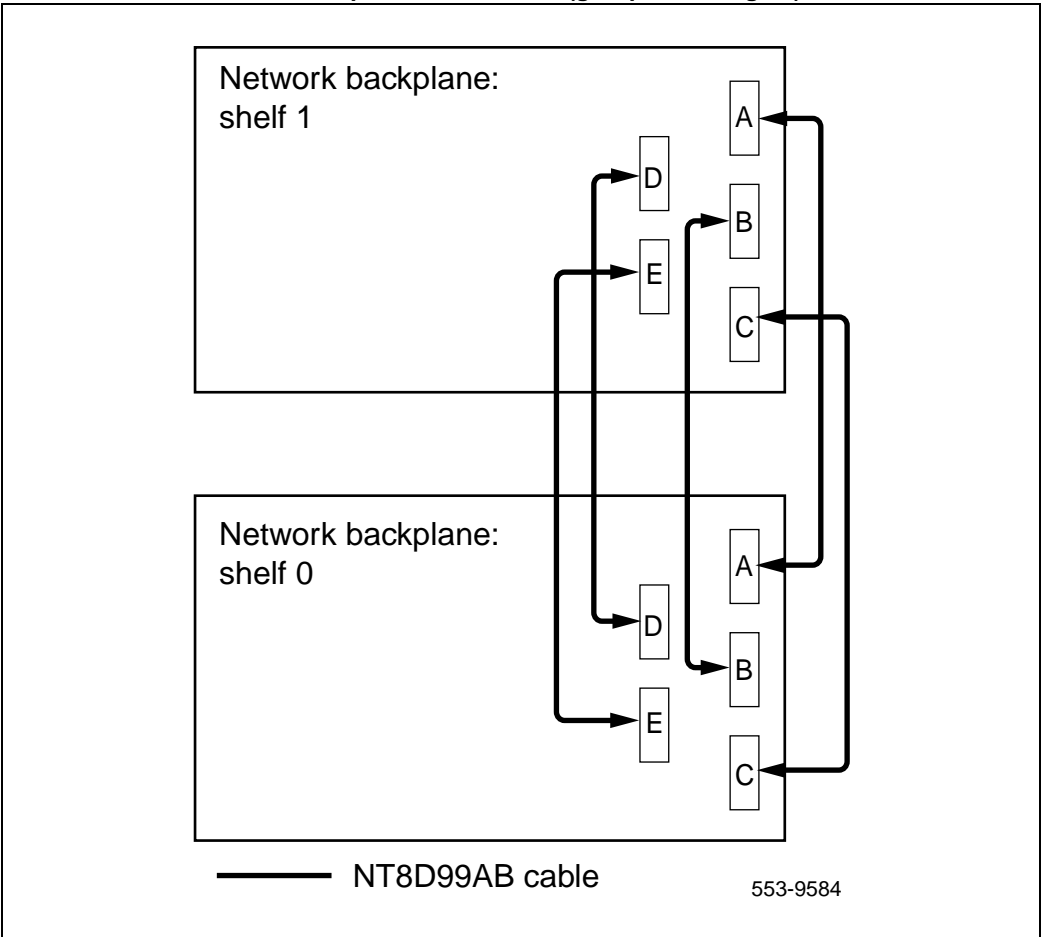

Connect the Network modules to the Core/Net modules

Each Network shelf contains one 3PE card. These 3PE cards are connected to the Termination Panel in the back of the Core/Net shelves.

Figure 84 on page 162, Figure 85 on page 163 and Figure 85 on page 163 show the location of the Termination Panel and 3PE cables on the Core/Net backplane.

Figure 84
3PE Termination Panel in the Core/Net module (top view)

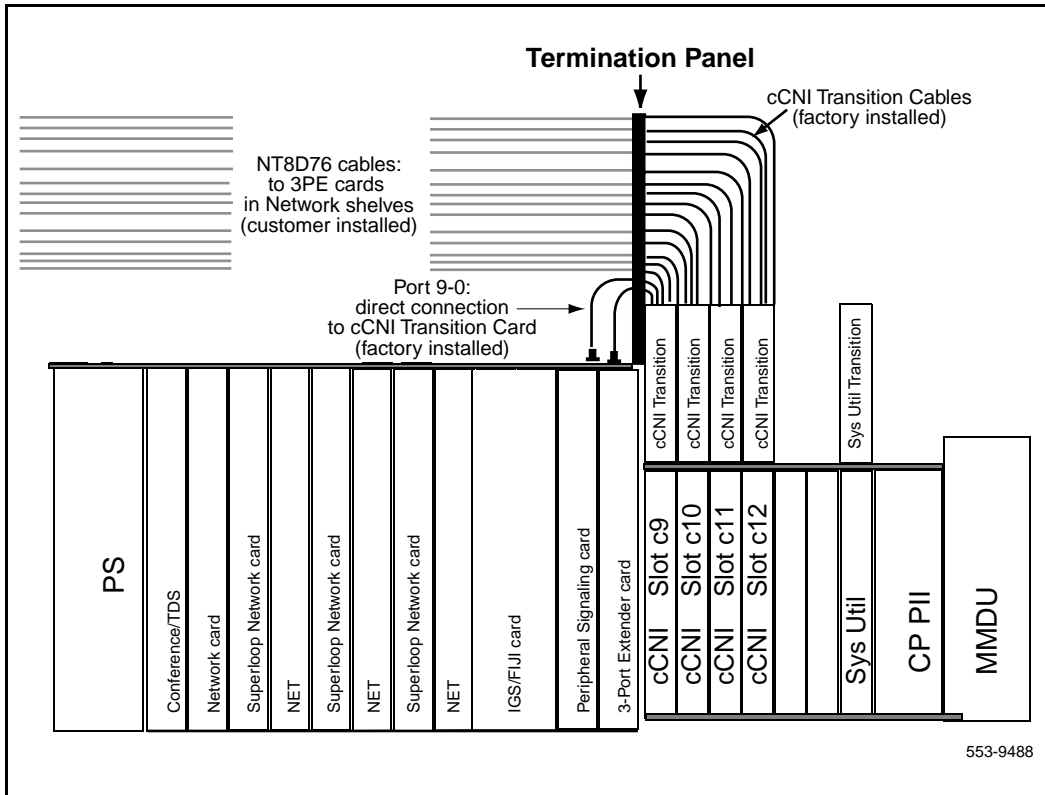

cCNI slot and port assignments

Each system contains a minimum of one and a maximum of four CNI cards. Each cCNI card contains two ports to support up to two Network groups.

cCNI cards are identified by slot and port. Each port is assigned in software to a specific Network group. Use the System Layout Plan to determine the connections for your system.

- Each 3PE card has two faceplate connections: J3 and J4. Two cables are used for each card.

Figure 85
Core/Net backplane (rear view)

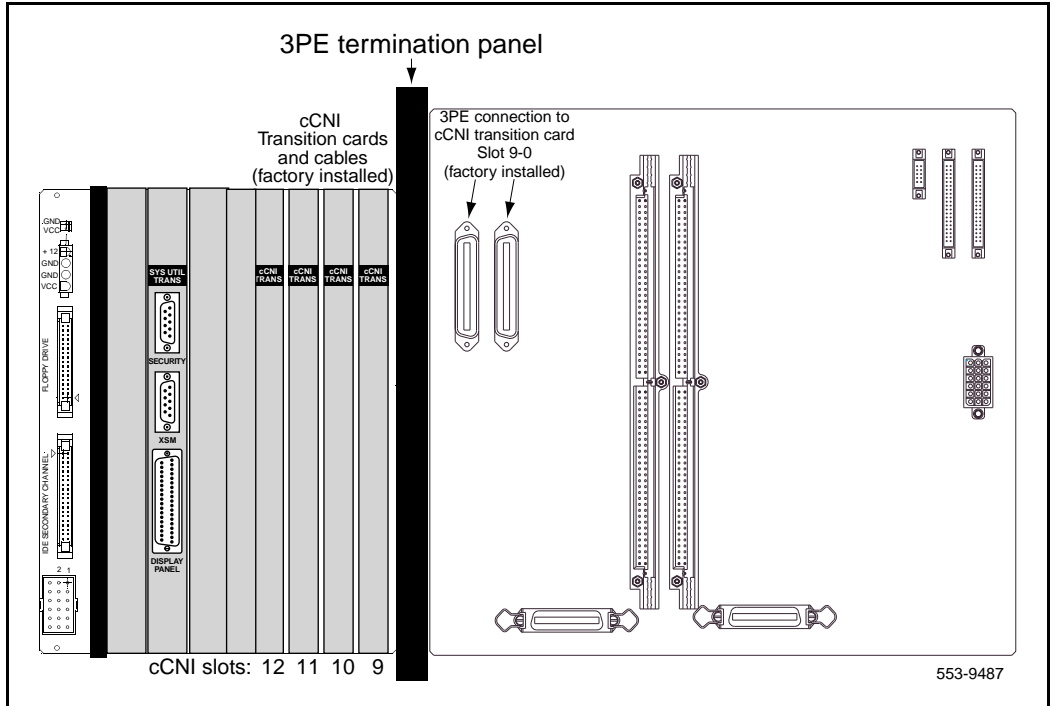

- 3PE cards in Network shelves “0” are connected to the 3PE Termination Panel in Core/Net 0.
- 3PE cards in Network shelves “1” are connected to the 3PE Termination Panel in Core/Net 1.

Figure 86
3PE Termination Panel (rear module view)

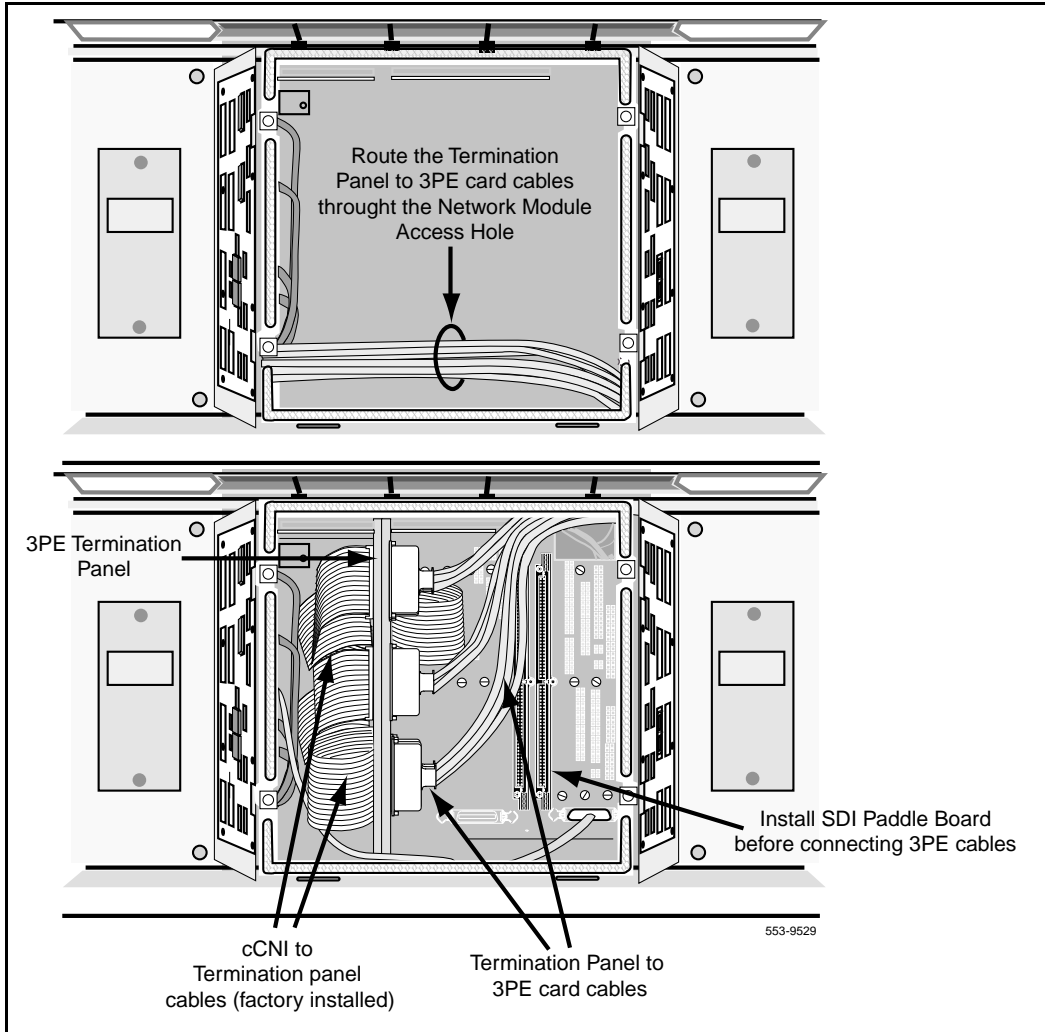

Table 18 on page 165 specifies the Network group assignments for each cCNI slot and port. These designations can not be changed in software.

Table 18
cCNI Network group designations

cCNI card slot	cCNI card port	3PE Termination Panel label	Connected to Network group
c9	0	N/A (factory installed directly to the Core/Net backplane)	0
c9	1	Port 9-1	1
c10	0	Port 10-0	2
c10	1	Port 10-1	3
c11	0	Port 11-0	4
c11	1	Port 11-1	5
c12	0	Port 12-0	6
c12	1	Port 12-1	7

cCNI to 3PE Termination Panel cable connections

The cCNI slot and port connections are labeled on the 3PE Termination Panel. See Figure 87 on page 166. Each 3PE card is connected with two cables: one to J3 and one to J4. Table 18 on page 165 specifies the Network group that connects to each slot.

Connect the 3PE cables to the 3PE Termination Panels

Two NT8D76 cables connect from J3 and J4 of each 3PE faceplate to the 3PE Termination Panel. See Figure 88 on page 168.

Refer to Table 18 on page 165 for cCNI port and slot assignments. Connect shelf 0 3PE cards to the Core/Net 0 panel; connect shelf 1 3PE cards to the Core/Net 1 panel. The 3PE cables for Network group 0 are factory installed.

Figure 87
3PE Termination Panel (Core/Net module)

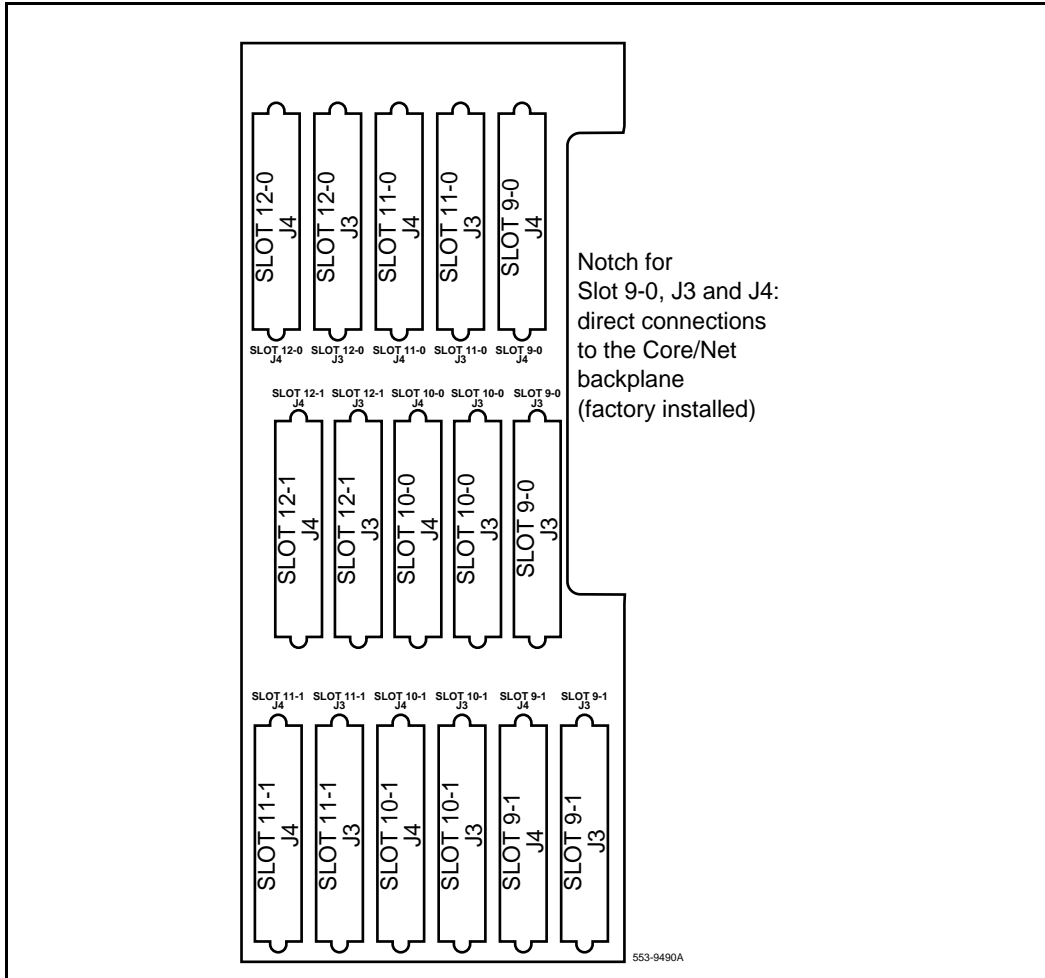

Connect the Network shelf 0 3PE cards to Core/Net 0

- 1 Connect a NT8D76 cable of the appropriate length from J3 on the 3PE card faceplate in **Network group 1, shelf 0** to the **Port 9-1, J3** connection on the 3PE Termination Panel in **Core/Net 0**.
- 2 Connect a NT8D76 cable of the appropriate length from J4 on the 3PE card faceplate in **Network group 1, shelf 0** to the **Port 9-1, J4** connection on the 3PE Termination Panel in **Core/Net 0**.
- 3 Connect a NT8D76 cable of the appropriate length from J3 on the 3PE card faceplate in **Network group 2, shelf 0** to the **Port 10-0, J3** connection on the 3PE Termination Panel in **Core/Net 0**.
- 4 Connect a NT8D76 cable of the appropriate length from J4 on the 3PE card faceplate in **Network group 2, shelf 0** to the **Port 10-0, J4** connection on the 3PE Termination Panel in **Core/Net 0**.
- 5 Install the remaining cables according to the assignments in Table 18 on page 165.

Connect the Network shelf 1 3PE cards to Core/Net 1

- 1 Connect a NT8D76 cable of the appropriate length from J3 on the 3PE card faceplate in **Network group 1, shelf 1** to the **Port 9-1, J3** connection on the 3PE Termination Panel in **Core/Net 1**.
- 2 Connect a NT8D76 cable of the appropriate length from J4 on the 3PE card faceplate in **Network group 1, shelf 1** to the **Port 9-1, J4** connection on the 3PE Termination Panel in **Core/Net 1**.
- 3 Connect a NT8D76 cable of the appropriate length from J3 on the 3PE card faceplate in **Network group 2, shelf 1** to the **Port 10-0, J3** connection on the 3PE Termination Panel in **Core/Net 1**.
- 4 Connect a NT8D76 cable of the appropriate length from J4 on the 3PE card faceplate in **Network group 2, shelf 1** to the **Port 10-0, J4** connection on the 3PE Termination Panel in **Core/Net 1**.
- 5 Install the remaining cables according to the assignments in Table 18 on page 165.

Figure 88
Example of 3PE faceplate to 3PE Termination Panel connection

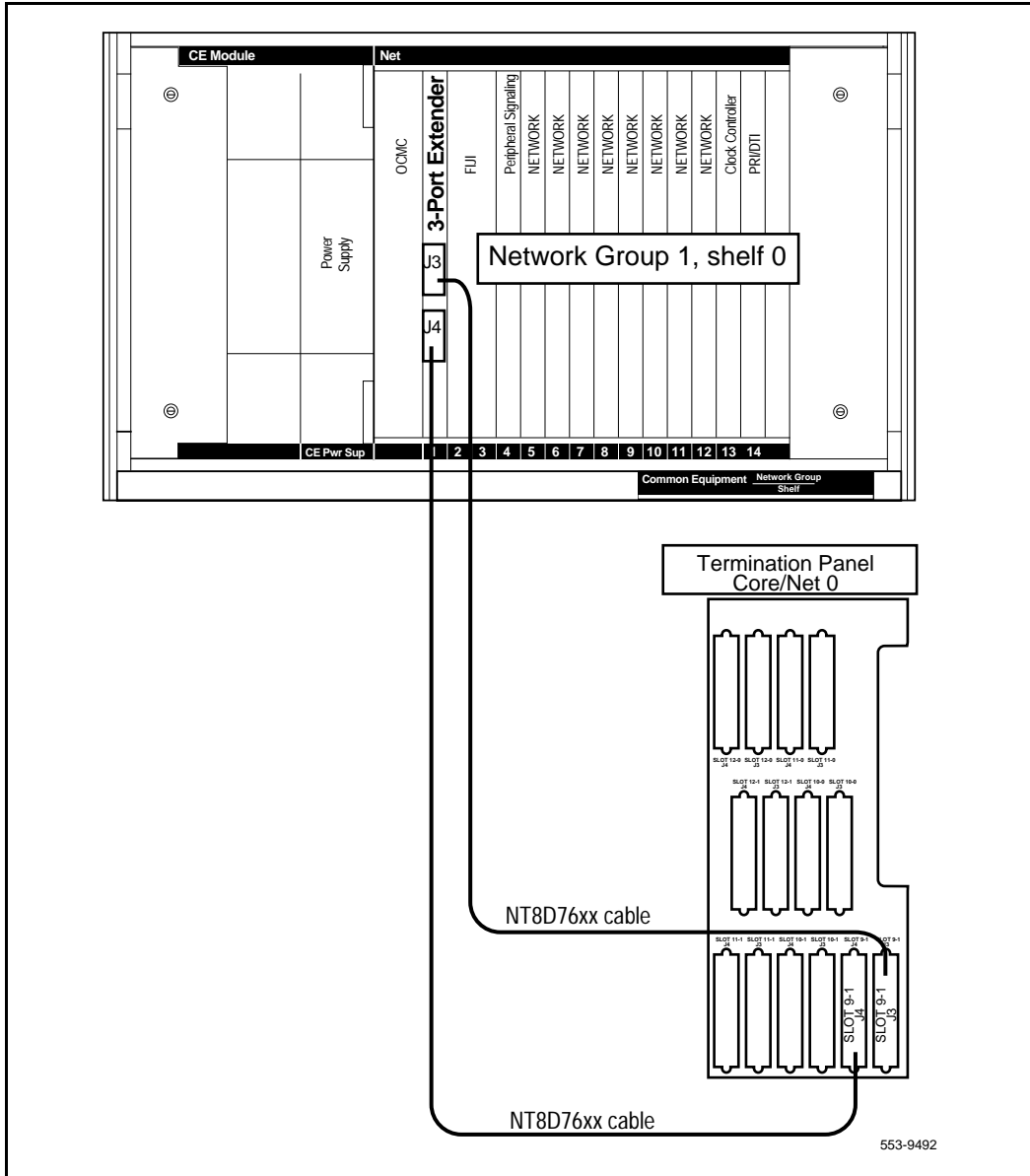

Option 61C and 81C network card connections

NT8D04 Superloop Network Card

Depending on whether your system is configured as a single row of columns or double row of columns, proceed with ““Basic cabling for single-row network connections” on page 169,” below, or “Basic cabling for multiple-row network connections” on page 172.

**CAUTION**
System Failure

Due to the possibility of EMI/RFI noise, do not route cables from front to rear next to the power supply unit.

Basic cabling for single-row network connections

- 1 Refer to the work order and the cabling layout shipped with the system to determine:
 - each loop number assigned
 - the module and slot assignments for the NT8D04 Superloop Network Card associated with each loop
 - the location of NT8D37 IPE Modules that contain NT8D01 Controller Cards associated with each loop
- 2 Set the Enb/Dis switch on each superloop network card to Dis.
- 3 Cable network loops from the faceplate connector on the superloop network card to the backplane for associated controller cards (see Table 19 on page 177).
 - Label both ends of an NT8D91 cable with the loop number, then connect one end of the cable to the superloop network card faceplate connector:
 - J1 for shelf 1

— J2 for shelf 0

- On the backplane for the controller card, connect the cable to the SL0, SL1, SL2, or SL3 connector assigned to the loop.

Note: The key (polarizing tab) on the side of the cable connector must be inserted into the keyway on the left side, facing the backplane, of the backplane connector. Blue and white wires should show through the top of the cable connector and, if there is a directional label, the arrow on the cable connector should be located at the top right.

- Figure 89 on page 171 shows the superloop network card faceplate connectors, the backplane connectors for the controller card, and the cables required.

- 4 Seat and secure all connectors.
- 5 Set the Enb/Dis switch on each network card to Enb.
- 6 During system software configuration, use the *Administration* (553-3001-311) to enter loop assignments.

Figure 89
NT8D04 Superloop Network Card network loops—connectors for single-row connections

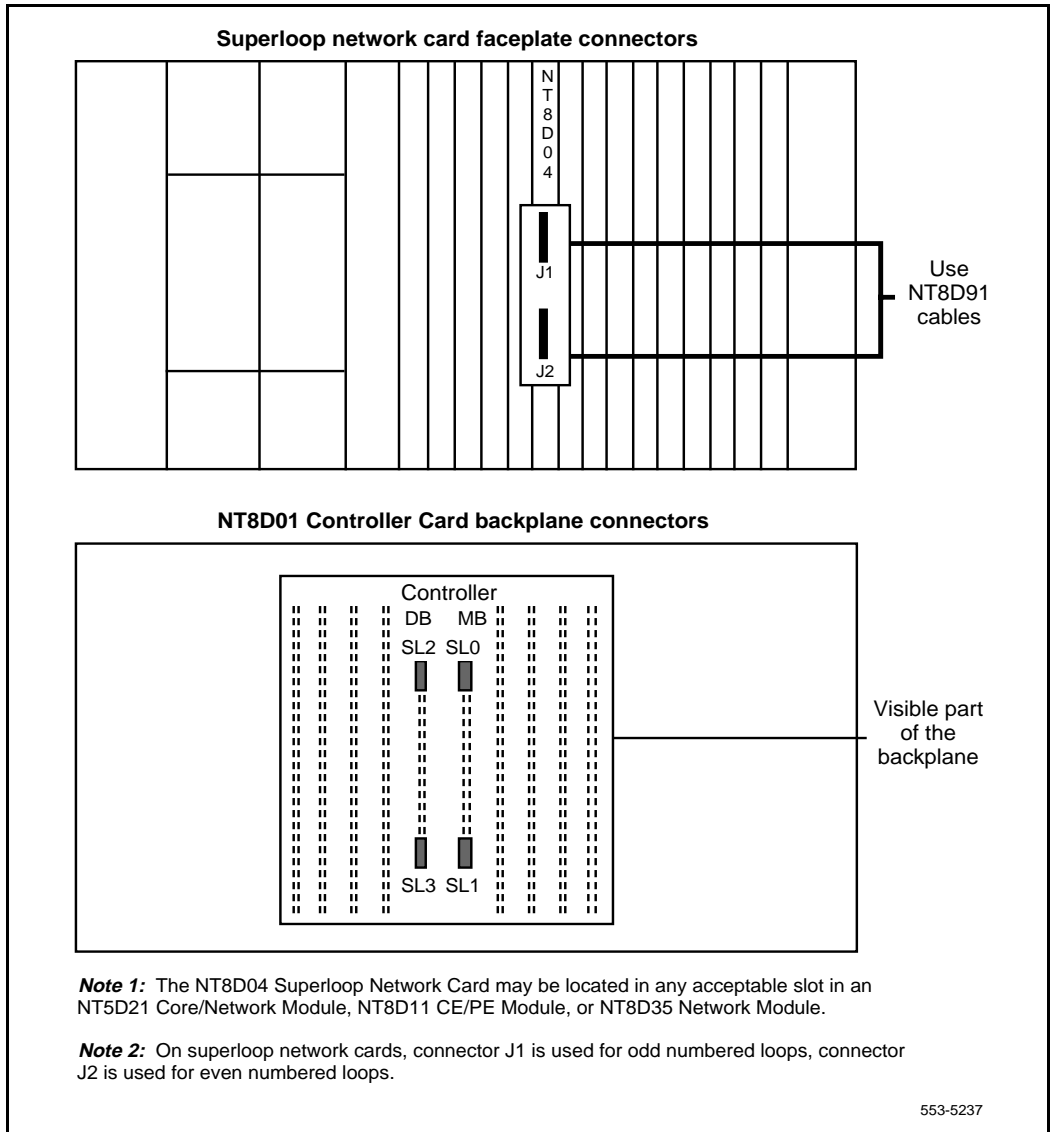

Basic cabling for multiple-row network connections

- 1 Refer to the work order and the cabling layout shipped with the system to determine
 - each loop number assigned
 - the module and slot assignments of the NT8D04 Superloop Network Card associated with each loop
 - the location of NT8D37 IPE Modules that contain NT8D01 Controller Cards associated with each loop
- 2 Set the Enb/Dis switch on the faceplate of each network card to Dis.
- 3 Install NT8D1107 Superloop Adapter Plates on universal I/O panels (P0715058), if required. The superloop adapter plate reduces a QPC414 network loop cutout to the size for a superloop connection.

The recommended order for installing superloop adapter plates is over I/O panel locations J2, J6, J10, J22, J26, J31.

- Position the adapter plate over the QPC414 cutout and install the screw and washer at the bottom of the plate.
 - Position the cable connector on the adapter plate and install one screw and washer at the top and one screw and washer at the bottom of the connector.
 - Figure 90 on page 173 shows mounting details for the superloop adapter plate.
- 4 Cable network loops from the faceplate connector on the network card to the I/O panels on the rear of the Core/Net or Network Module.
 - Label both ends of an NT8D88AD cable with the loop number, then connect one end of the cable to the network card faceplate connector:
 - J1 for shelf 1
 - J2 for shelf 0
 - Route the cable around the card cage to the I/O panel and mount the cable connector in one of the cutouts in the panel.
 - the recommended order for connections is J16, J17, J37, J38, then, with superloop adapter plates, J2, J6, J10, J22, J26, J31
 - Figure 91 on page 175 shows the network card faceplate connectors, the I/O panel connectors, and the cables required.

Figure 90
Installing a superloop adapter plate

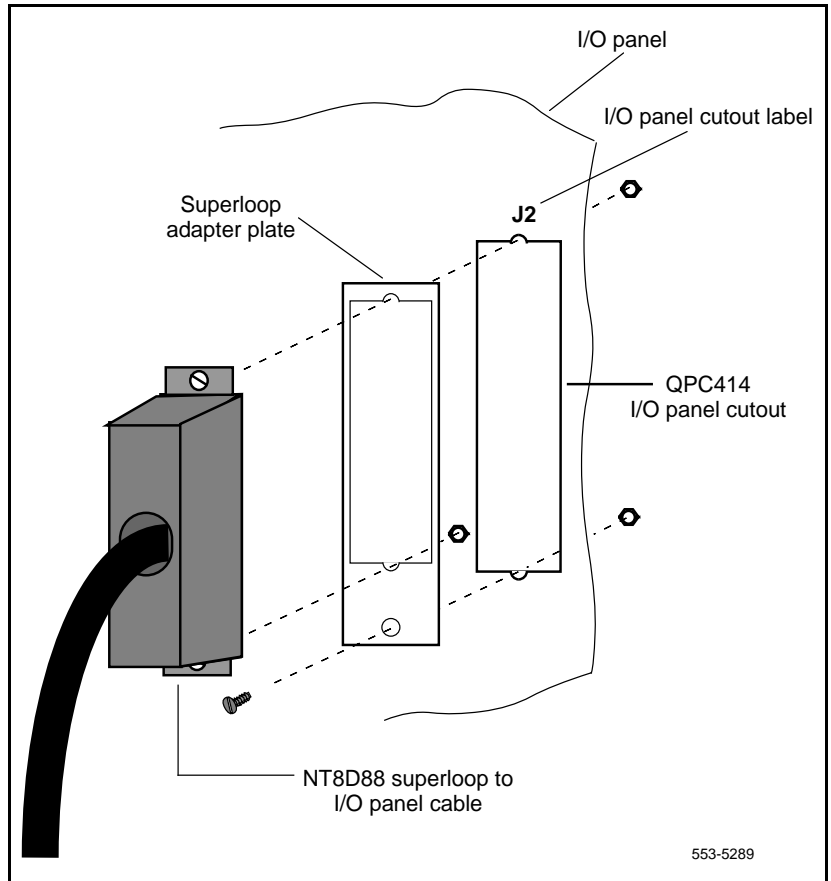

- 5 Cable the backplane connectors (SL0, SL1, SL2, SL3) for the controller card to the I/O panels on the rear of the IPE Module.
- Label both ends of an NT8D92 cable with the loop number, then connect one end of the cable to the backplane connector.
 - Mount the connector on the other end of the cable in one of the cutouts in the I/O panels. The recommended order for connections is:
 - SL0 to J2

- SL1 to J3
 - SL2 to J4
 - SL3 to J5
- Figure 92 on page 176 shows the controller card backplane connectors and the I/O panels for the IPE Module.
- 6 Complete the network loop connection (see Table 19 on page 177).
 - Connect one end of an NT8D98 cable to the I/O panel connector for the network card.
 - Connect the other end of the cable to the I/O panel connector for the associated controller card.
 - 7 Seat and secure all connectors.
 - 8 Set the Enb/Dis switch on each network card to Enb.
 - 9 During system software configuration, use the *Administration* (553-3001-311) to enter loop assignments.

Figure 91
NT8D04 Superloop Network Card network loops—network card to I/O panel connections

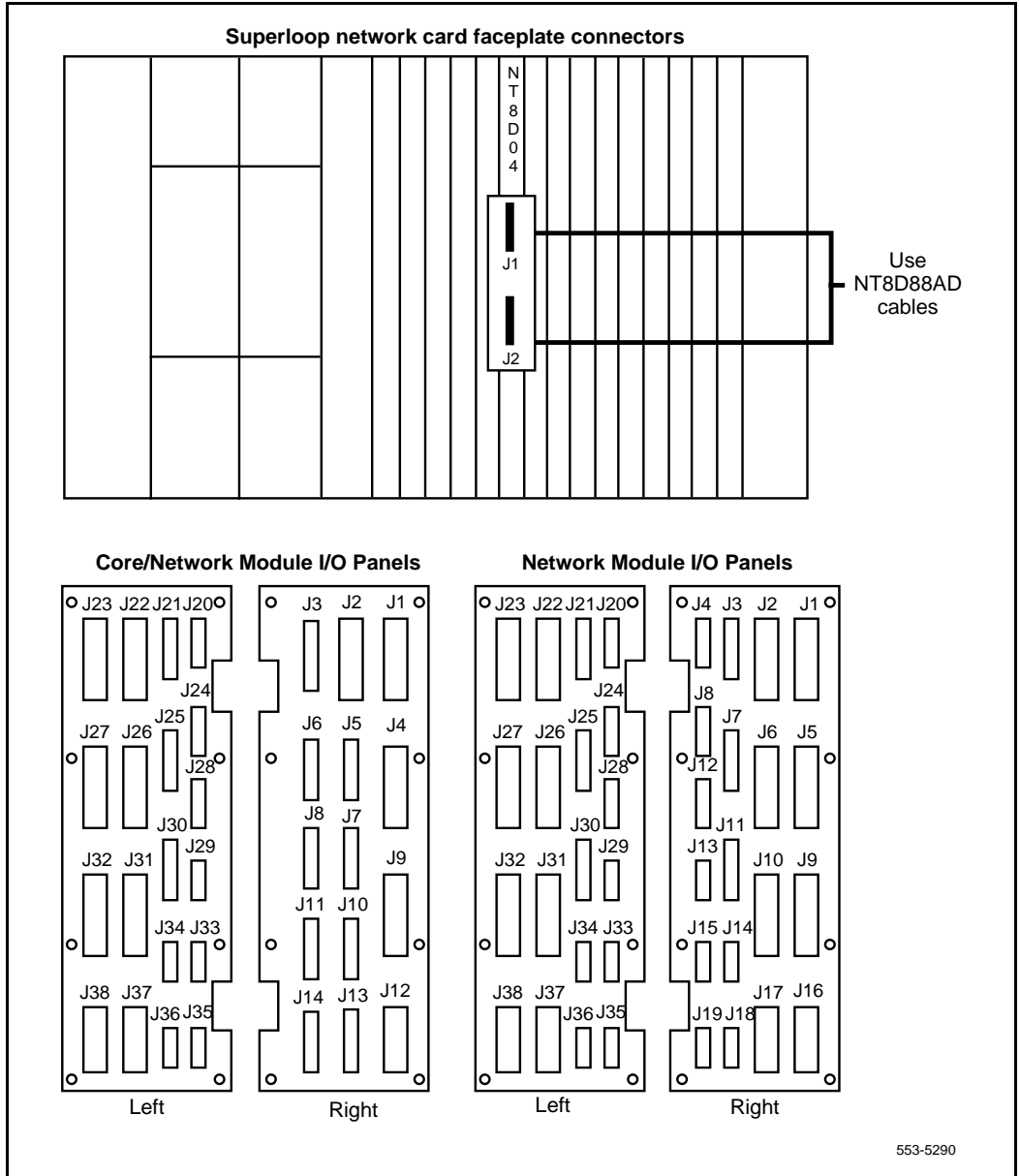

Figure 92
NT8D04 Superloop Network Card network loops—controller card to I/O panel connections

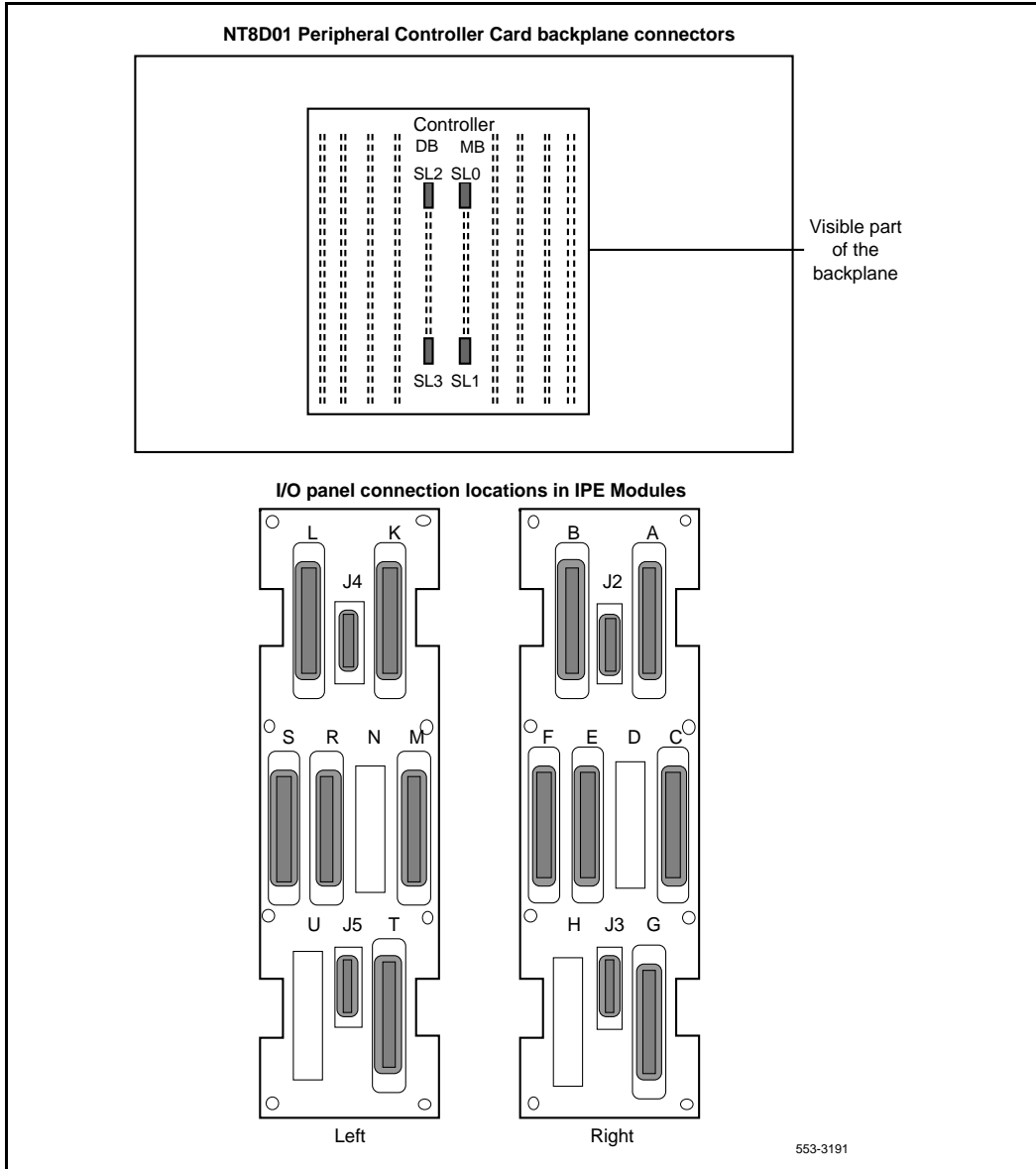

Table 19
NT8D04 network loop configurations

	FROM		TO	
	Superloop network card	Faceplate connector	Controller card	Backplane connector
One segment per superloop	NT8D04 #1	J2	NT8D01AC #1	SL0
	NT8D04 #2	J2	NT8D01AC #1	SL1
	NT8D04 #3	J2	NT8D01AC #1	SL2
	NT8D04 #4	J2	NT8D01AC #1	SL3
Two segments per superloop	NT8D04 #1	J2	NT8D01AD #1	SL0
	NT8D04 #2	J2	NT8D01AD #1	SL1
Four segments per superloop	NT8D04 #1	J2	NT8D01AD #1	SL0
Eight segments per superloop	NT8D04 #1	J2	NT8D01AD #1	SL0
	NT8D04 #1	J1	NT8D01AD #2	SL0
One segment per superloop/three segments per another superloop	NT8D04 #1	J2	NT8D01AD #1	SL0
	NT8D04 #2	J2	NT8D01AD #1	SL1
Two segments per superloop/six segments per another superloop	NT8D04 #1	J2	NT8D01AC #1	SL0
	NT8D04 #2	J2	NT8D01AC #2	SL0
	NT8D04 #2	J1	NT8D01AC #2	SL1
Note:	NT8D01AC is a controller-4 NT8D01AD is a controller-2			

QPC414 Network Card

Depending on whether your system is configured as a single row of columns or double row of columns, proceed with ““Basic cabling for single-row network connections” on page 178,” below, or “Basic cabling for multiple-row network connections” on page 180.



CAUTION

System Failure

Due to the possibility of EMI/RFI noise, do not route cables from front to rear next to the power supply unit.

Basic cabling for single-row network connections

- 1 Refer to the work order and the cabling layout shipped with the system to determine
 - each loop number assigned
 - the module and slot assignments for the QPC414 Network Card associated with each loop
- 2 Set the Enb/Dis switch on the faceplate of each network card to Dis.
- 3 Cable network loops from the faceplate connector on the network card to the faceplate connector on the associated DLB card.
 - Label both ends of an NT8D85 cable with the loop number, then connect one end of the cable to the network card faceplate connector:
 - J1 for shelf 0
 - J2 for shelf 1
 - On the DLB card, connect the cable to the LPX or LPY connector assigned to the loop.
 - Figure 93 on page 179 shows the network card and DLB card connectors and the cables required.
- 4 Seat and secure all connectors.
- 5 Set the Enb/Dis switch on each network card to Enb.

Figure 93
QPC414 Network Card network loops—connectors and cables for single-row connections

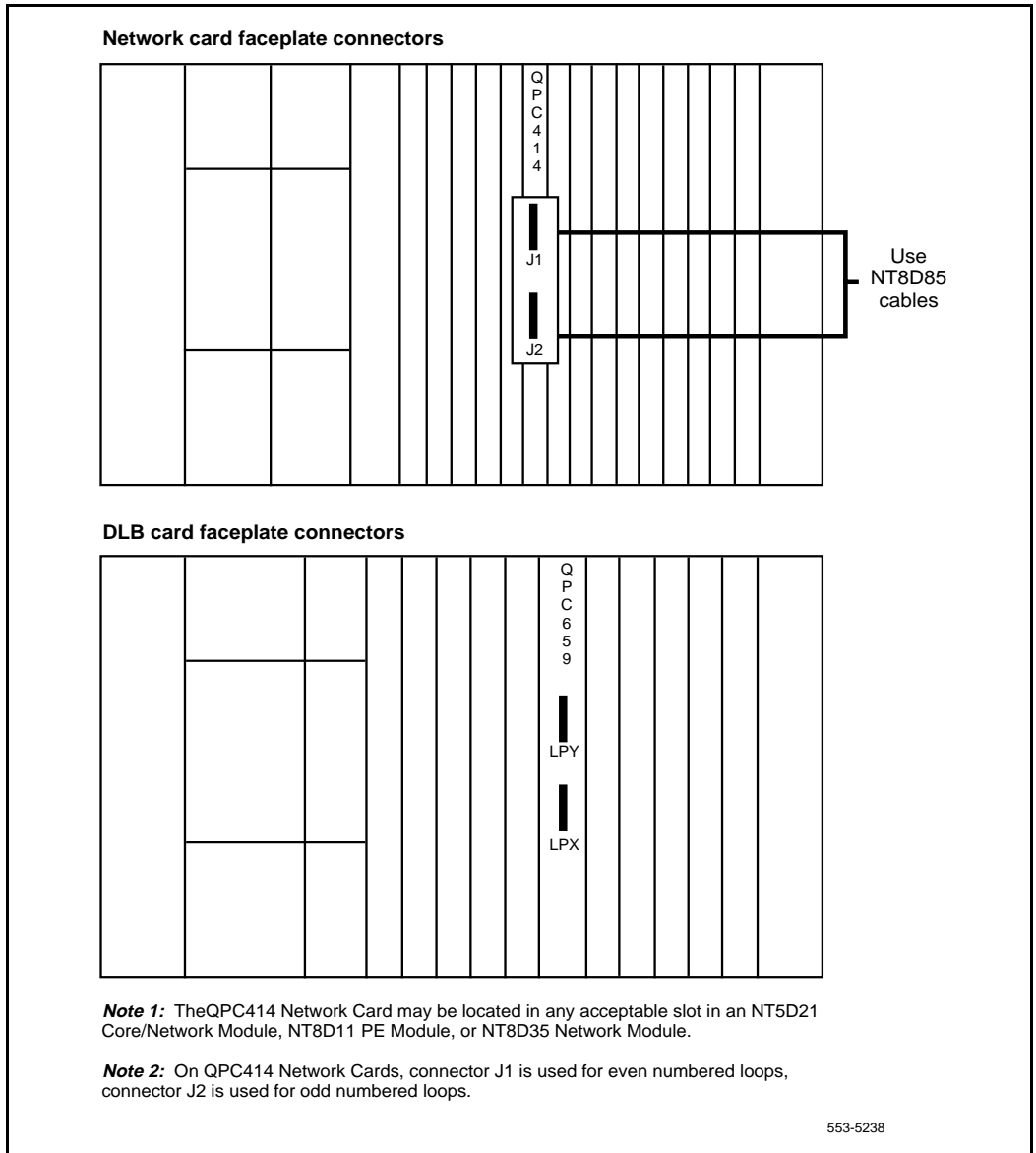

- 6 During system software configuration, use the *Administration* (553-3001-311) to enter loop assignments.

Basic cabling for multiple-row network connections

- 1 Refer to the work order and the cabling layout shipped with the system to determine
 - each loop number assigned
 - the module and slot assignments of the QPC414 Network Card associated with each loop
- 2 Set the Enb/Dis switch on the faceplate of each network card to Dis.
- 3 Cable network loops from the faceplate connector on the network card to the I/O panels on the rear of the Network Module.
 - Label both ends of an NT8D86AD cable with the loop number, then connect one end of the cable to the network card faceplate connector:
 - J1 for shelf 0
 - J2 for shelf 1
 - Route the cable around the card cage to the I/O panel and mount the cable connector in one of the cutouts in the panel.

the recommended order for connections is J1, J2, J5, J6, J9, J10, J22, J23, J26, J27, J31, J32
 - Figure 94 on page 181 shows the network card faceplate connectors, the universal I/O panel connectors, and the cables required.
- 4 Cable the DLB card to the I/O panels on the rear of the PE Module.
 - Label both ends of an NT8D86AD cable with the loop number, then connect one end of the cable to the assigned LPX or LPY faceplate connector on the DLB card.
 - Mount the connector on the other end of the cable in one of the cutouts in the I/O panels:
 - LPX to J1
 - LPY to J2
 - Figure 95 on page 182 shows the DLB card connectors, the I/O panels for the PE Module, and the cables required.

Figure 94
QPC414 Network Card network loops—network card to I/O panel connections

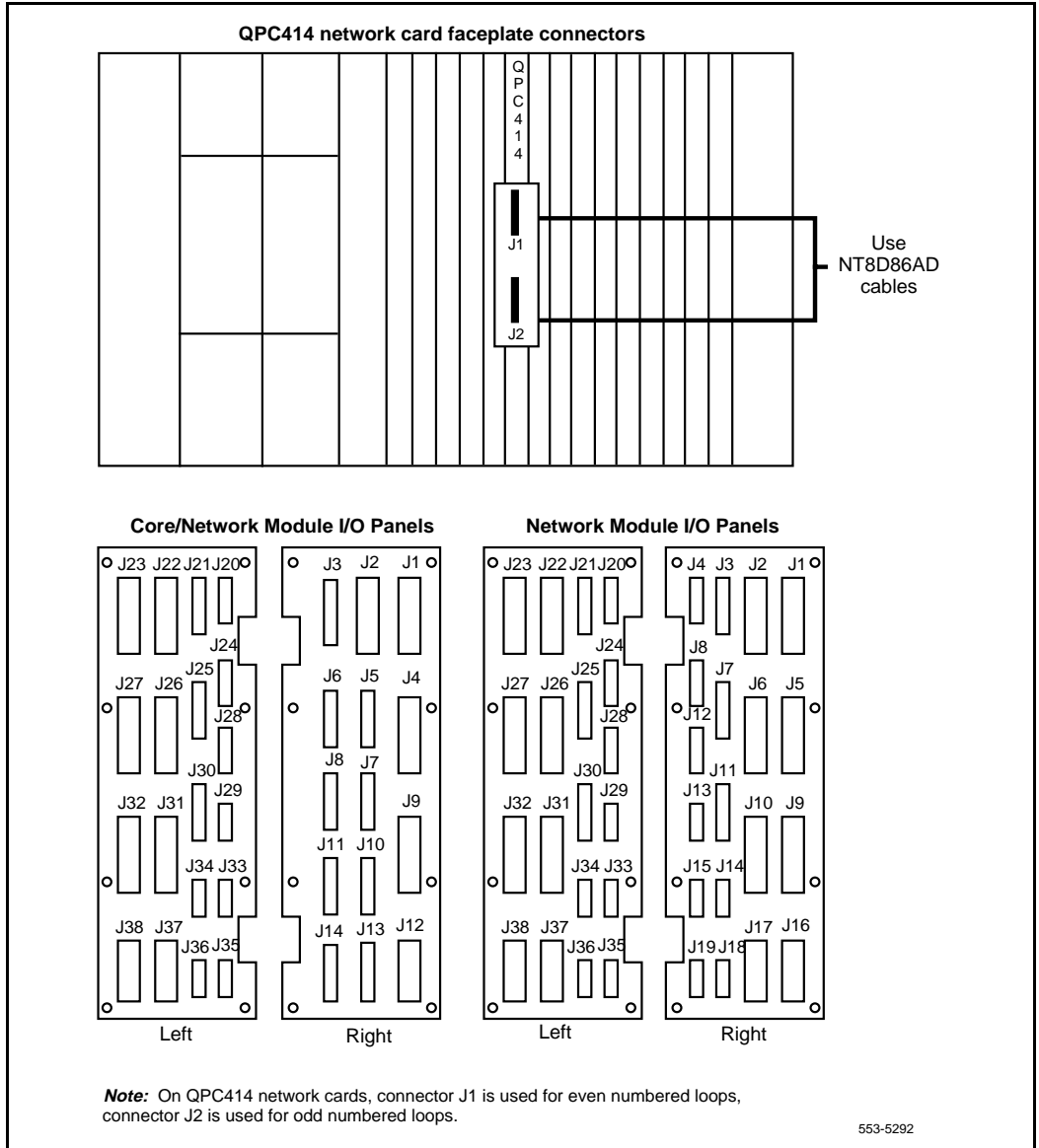
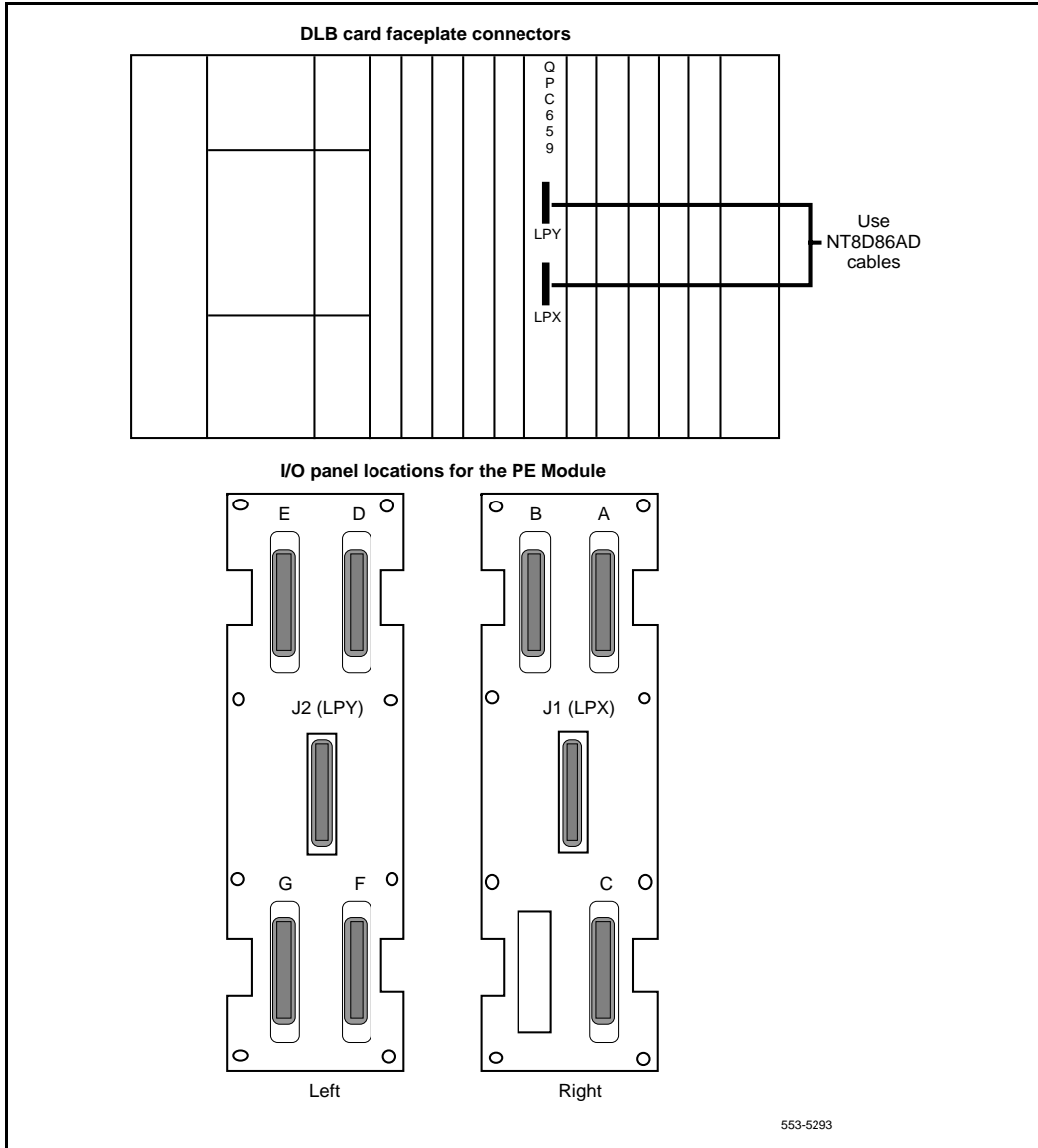

Figure 95
QPC414 Network Card network loops—DLB card to I/O panel connections



- 5 Complete the network loop connection.
 - Connect one end of an NT8D73 cable to the I/O panel connector for the network card.
 - Connect the other end of the cable to the I/O panel connector for the associated DLB card.
- 6 Seat and secure all connectors.
- 7 Set the Enb/Dis switch on each network card to Enb.
- 8 During system software configuration, use the *Administration* (553-3001-311) to enter loop assignments.

Cabling lines and trunks

Reference list

The following are the references in this section:

- *Administration* (553-3001-311)

Cables are designated by the letter of the I/O panel cutout (A, B, C, and so on) where the 50-pin cable connector is attached. Each cable has three 20-pin connectors (16 positions are used), designated 1, 2, and 3, that attach to the backplane. Using the designations described, the backplane ends of the first cable are referred to as A-1, A-2, and A-3.

The locations of the cable connectors on the backplane are designated by the slot number (L0 through L15 for NT8D37) and the shroud row (1, 2, and 3). Using these designations, the slot positions in the first slot are referred to as L0-1, L0-2, and L0-3.

In NT8D37BA and NT8D37EC (and later vintage) IPE Modules, all 16 IPE card slots support 24-pair cable connections. Table 20 on page 186 shows the cable connections from the backplane to the inside of the I/O panel. Figure 96 on page 187 shows the designations for the backplane end of the cables, the backplane slot designations for the cable connections, and the associated network segments for the backplane slots.

Table 20
NT8D37 cable connections

Backplane slots—shroud rows	I/O panel/cable designation
L0-1, 2, 3	A
L1-1, 2, 3	B
L2-1, 2, 3	C
L3-1, 2, 3	D
L4-1, 2, 3	E
L5-1, 2, 3	F
L6-1, 2, 3	G
L7-1, 2, 3	H
L8-1, 2, 3	K
L9-1, 2, 3	L
L10-1, 2, 3	M
L11-1, 2, 3	N
L12-1, 2, 3	R
L13-1, 2, 3	S
L14-1, 2, 3	T
L15-1, 2, 3	U

Note: To cable lines and trunks in NT8D11AC or DC modules (7-cable configuration), and in NT8D37AA or DC modules (12-cable configuration), go to Appendix C.

Figure 96
NT8D37 backplane cable designations

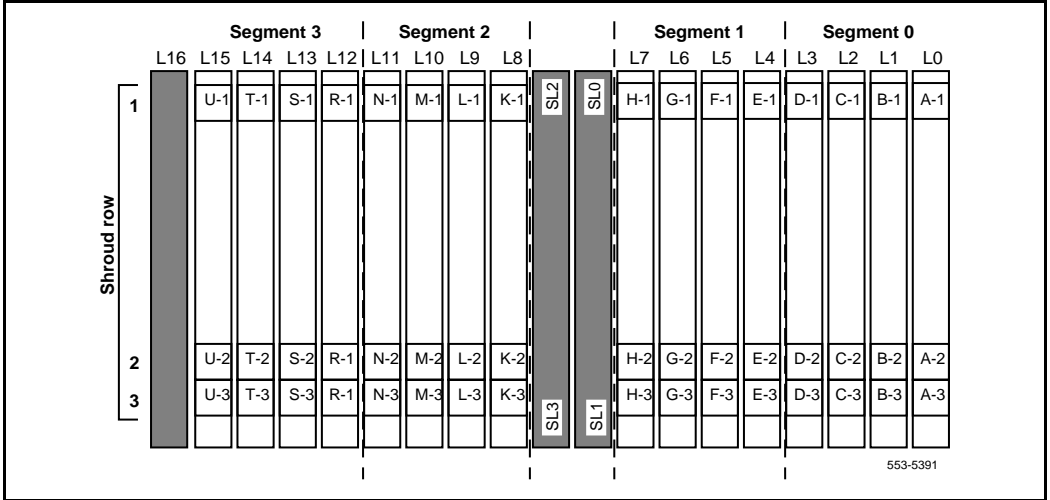

I/O panel connections

Use this procedure to cable NT8D37 IPE Modules.

Note: The corner vertical channels in the rear of the module are outside of the EMI shield. Cables in those vertical channels must be shielded, and must enter and exit the EMI-shielded area through I/O panels and adapters.



DANGER OF ELECTRIC SHOCK

Tip, ring, A, B, E, M, ESC, and ESCG connections may be considered to be Telecommunications Network Voltages (TNV).

- 1 Select an appropriate number of NE-A25B (or equivalent) cables long enough to run from the I/O panels on the rear of the module to the MDF.
 - Figure 97 on page 189 shows the I/O panels on the NT8D37 IPE Module.
- 2 Attach a tag that shows the module number and the I/O connector designation to both ends of each cable.
- 3 Connect each cable to the appropriate connector on the I/O panel and run the cables to the MDF.
- 4 Terminate each cable on the cross-connect block designated with the appropriate module number.

Note: For information on the MDF layout see “Planning and designating the Modular Distribution Frame (MDF)” on page 71.
- 5 Make sure all cables are neatly run, properly seated, and secured with cable ties.

Figure 97
NT8D37 IPE Module I/O panels

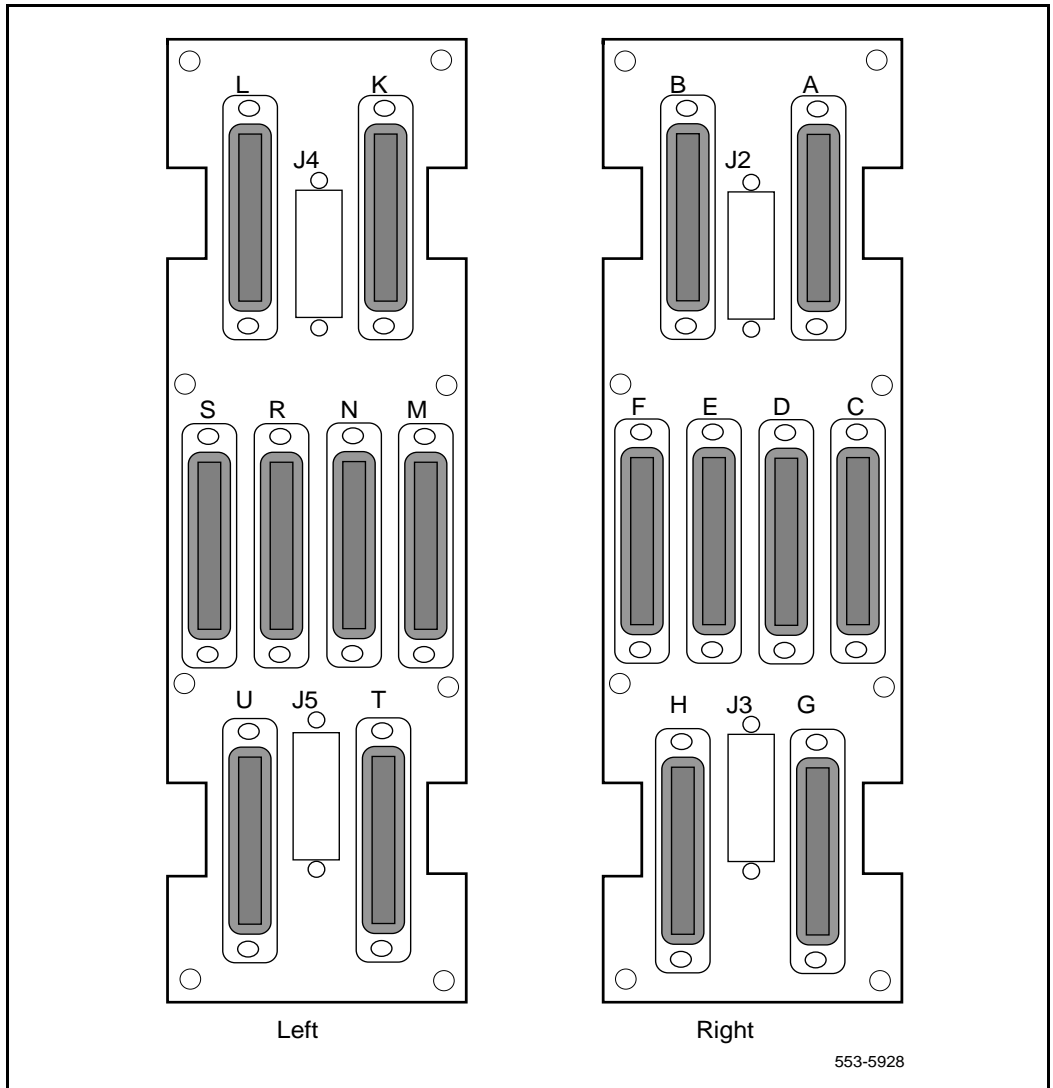

Connecting lines and trunks

Throughout this procedure, make sure wiring is not reversed and is on the proper terminals. Allow enough slack in the wiring to allow tracing and to reconnect wires if they break at the terminal.

- 1 Extend incoming wiring (such as cables from the central office or wiring from a recorded announcement machine) to the MDF and terminate them on separate connecting blocks.
- 2 Assign and record terminal numbers (TNs) for each line or trunk. Determine the location of the line or trunk connection and its assigned TN from the work order or assignment records.
- 3 Connect each line and trunk to the TN using cross-connecting wire (typically 24 AWG type-Z wire). Table 21 on page 190 lists pair-termination tables for line and trunk cards in NT8D37 IPE Modules.

Cross-connect incoming wiring and lines and trunks at the MDF..

Table 21
Line and trunk pair-termination tables

NT8D37 IPE Module	
Line cards	Table 22
Trunk cards	NT8D14 Universal Trunk Card: Table 23 NT8D15 E&M Trunk Card: Figures 24 through 26 NT5K17 DDI Trunk card; Tables 28 through 30 NT5K18 Flexible Central Office Trunk card; Tables 31 through 33 NT5K19 Flexible E&M Trunk card; Tables 34 through 46

Table 22
NT8D37 IPE Module: line card pair-terminations

Pair	Pin numbers	Pair color	Unit 24/card
1T/1R	26/1	W-BL/BL-W	0
2T/2R	27/2	W-O/O-W	1
3T/3R	28/3	W-G/G-W	2
4T/4R	29/4	W-BR/BR-W	3
5T/5R	30/5	W-S/S-W	4
6T/6R	31/6	R-BL/BL-R	5
7T/7R	32/7	R-O/O-R	6
8T/8R	33/8	R-G/G-R	7
9T/9R	34/9	R-BR/BR-R	8
10T/10R	35/10	R-S/S-R	9
11T/11R	36/11	BK-BL/BL-BK	10
12T/12R	37/12	BK-O/O-BK	11
13T/13R	38/13	BK-G/G-BK	12
14T/14R	39/14	BK-BR/BK-BR	13
15T/15R	40/15	BK-S/S-BK	14
16T/16R	41/16	Y-BL/BL-Y	15
17T/17R	42/17	Y-O/O-Y	16
18T/18R	43/18	Y-G/G-Y	17
19T/19R	44/19	Y-BR/BR-Y	18
20T/20R	45/20	Y-S/S-Y	19
21T/21R	46/21	V-BL/BL-V	20
22T/22R	47/22	V-O/V-O	21
23T/23R	48/23	V-G/G-V	22
24T/24R	49/24	V-BR/BR-V	23
25T/25R	50/25	V-S/S-V	Spare

Note: Each of the following I/O panel connectors is cabled as shown above: connectors A, B, C, D, E, F, G, H, K, L, M, N, R, S, T, and U. These connectors are associated with backplane slots 0 through 15, sequentially.

Table 23
NT8D37 IPE Module: NT8D14 Universal Trunk Card pair-terminations

Lead designations			Pin numbers	Pair color	Unit
RAN mode	Paging mode	Other modes			
0T/0R CP/MB	0T/0R A/PG	0T/0R	26/1 27/2	W-BL/BL-W W-O/O-W	0
1T/1R CP/MB	1T/1R A/PG	1T/1R	28/3 29/4	W-G/G-W W-BR/BR-W	1
2T/2R CP/MB	2T/2R A/PG	2T/2R	30/5 31/6	W-S/S-W R-BL/BL-R	2
3T/3R CP/MB	3T/3R A/PG	3T/3R	32/7 33/8	R-O/O-R R-G/G-R	3
4T/4R CP/MB	4T/4R A/PG	4T/4R	34/9 35/10	R-BR/BR-R R-S/S-R	4
5T/5R CP/MB	5T/5R A/PG	5T/5R	36/11 37/12	BK-BL/BL-BK BK-O/O-BK	5
6T/6R CP/MB	6T/6R A/PG	6T/6R	38/13 39/14	BK-G/G-BK BK-BR/BK-BR	6
7T/7R CP/MB	7T/7R A/PG	7T/7R	40/15 41/16	BK-S/S-BK Y-BL/BL-Y	7

Note 1: Each of the following I/O panel connectors is cabled as shown above: connectors A, B, C, D, E, F, G, H, K, L, M, N, R, S, T, and U. These connectors are associated with backplane slots 0 through 15, sequentially.

Note 2: Use LD 14 to select trunk termination impedance (600 ohm or 900 ohm). See the *Administration* (553-3001-311) for information on LD 14.

Table 24
NT8D37 IPE Module: NT8D15 E&M Trunk Card 2-wire paging mode
pair-terminations

Pair	Pin numbers	Pair color	Unit
0T/0R A/PG	26/1 29/4	W-BL/BL-W W-BR/BR-W	0
1T/1R A/PG	30/5 33/8	W-S/S-W R-G/G-R	1
2T/2R A/PG	34/9 37/12	R-BR/BR-R BK-O/O-BK	2
3T/3R A/PG	38/13 41/16	BK-G/G-BK Y-BL/BL-Y	3
<p>Note: Each of the following I/O panel connectors is cabled as shown above: connectors A, B, C, D, E, F, G, H, K, L, M, N, R, S, T, and U. These connectors are associated with backplane slots 0 through 15, sequentially.</p>			

Table 25
NT8D37 IPE Module: NT8D15 E&M Trunk Card 2-wire type 1 mode
pair-terminations

Pair	Pin numbers	Pair color	Unit
0T/0R E/M	26/1 28/3	W-BL/BL-W W-G/G-W	0
1T/1R E/M	30/5 32/7	W-S/S-W R-O/O-R	1
2T/2R E/M	34/9 36/11	R-BR/BR-R BK-BL/BL-BK	2
3T/3R E/M	38/13 40/15	BK-G/G-BK BK-S/S-BK	3
<p>Note: Each of the following I/O panel connectors is cabled as shown above: connectors A, B, C, D, E, F, G, H, K, L, M, N, R, S, T, and U. These connectors are associated with backplane slots 0 through 15, sequentially.</p>			

Table 26
NT8D37 IPE Module: NT8D15 E&M Trunk Card 4-wire type 1 and type 2 mode
pair-terminations

Lead designations		Pin numbers	Pair color	Unit
Type 1	Type 2			
TA/TB	TA/TB	26/1	W-BL/BL-W	0
RA/RB	RA/RB	27/2	W-O/O-W	
E/M	EA/EB	28/3	W-G/G-W	
ESC/ESCG	MA/MB	29/4	W-BR/BR-W	
TA/TB	TA/TB	30/5	W-S/S-W	1
RA/RB	RA/RB	31/6	R-BL/BL-R	
E/M	EA/EB	32/7	R-O/O-R	
ESC/ESCG	MA/MB	33/8	R-G/G-R	
TA/TB	TA/TB	34/9	R-BR/BR-R	2
RA/RB	RA/RB	35/10	R-S/S-R	
E/M	EA/EB	36/11	BK-BL/BL-BK	
ESC/ESCG	MA/MB	37/12	BK-O/O-BK	
TA/TB	TA/TB	38/13	BK-G/G-BK	3
RA/RB	RA/RB	39/14	BK-BR/BR-BK	
E/M	EA/EB	40/15	BK-S/S-BK	
ESC/ESCG	MA/MB	41/16	Y-BL/BL-Y	

Note 1: Each of the following I/O panel connectors is cabled as shown above: connectors A, B, C, D, E, F, G, H, K, L, M, N, R, S, T, and U. These connectors are associated with backplane slots 0 through 15, sequentially.

Note 2: TA/TB is the transmit pair; RA/RB is the receive pair.

Table 27
NT8D37 IPE Module: NT8D15 E&M Trunk Card 4-wire type 1 and type 2 mode
pair-terminations

Lead designations		Pin numbers	Pair color	Unit
Type 1	Type 2			
TA/TB	TA/TB	26/1	W-BL/BL-W	0
RA/RB	RA/RB	27/2	W-O/O-W	
E/M	EA/EB	28/3	W-G/G-W	
ESC/ESCG	MA/MB	29/4	W-BR/BR-W	
TA/TB	TA/TB	30/5	W-S/S-W	1
RA/RB	RA/RB	31/6	R-BL/BL-R	
E/M	EA/EB	32/7	R-O/O-R	
ESC/ESCG	MA/MB	33/8	R-G/G-R	
TA/TB	TA/TB	34/9	R-BR/BR-R	2
RA/RB	RA/RB	35/10	R-S/S-R	
E/M	EA/EB	36/11	BK-BL/BL-BK	
ESC/ESCG	MA/MB	37/12	BK-O/O-BK	
TA/TB	TA/TB	38/13	BK-G/G-BK	3
RA/RB	RA/RB	39/14	BK-BR/BR-BK	
E/M	EA/EB	40/15	BK-S/S-BK	
ESC/ESCG	MA/MB	41/16	Y-BL/BL-Y	

Note 1: Each of the following I/O panel connectors is cabled as shown above: connectors A, B, C, D, E, F, G, H, K, L, M, N, R, S, T, and U. These connectors are associated with backplane slots 0 through 15, sequentially.

Note 2: TA/TB is the transmit pair; RA/RB is the receive pair.

Table 28
NT5K17 Direct Dial Inward Trunk connections for NT8D37 I/O panel connectors A, E, K, R

Lead designations	Pins	Pair color	I/O panel connectors				Unit number
			A	E	K	R	
T0 R0	26 1	W-BL BL-W	Slot 0	Slot 4	Slot 8	Slot 12	Unit 0
	27 2	W-O O-W					
T1 R1	28 3	W-G G-W					Unit 1
	29 4	W-BR BR-W					
T2 R2	30 5	W-S S-W					Unit 2
	31 6	R-BL BL-R					
T3 R3	32 7	R-O O-R					Unit 3
	33 8	R-G G-R					
T4 R4	34 9	R-BR BR-R					Unit 4
	35 10	R-S S-R					
T5 R5	36 11	BK-BL BL-BK					Unit 5
	37 12	BK-S S-BK					
T6 R6	38 13	BK-G G-BK					Unit 6
	39 14	BK-BR BR-BK					
T7 R7	40 15	BK-S S-BK					Unit 7
	41 16	Y-BL BL-Y					

Table 29

NT5K17 Direct Dial Inward Trunk connections for NT8D37 I/O panel connectors B, F, L, S
(Part 1 of 2)

Lead designations	Pins	Pair color	I/O panel connectors				Unit number
			B	F	L	S	
T0 R0	26 1	W-BL BL-W	Slot 1	Slot 5	Slot 9	Slot 13	Unit 0
	27 2	W-O O-W					
T1 R1	28 3	W-G G-W					Unit 1
	29 4	W-BR BR-W					
T2 R2	30 5	W-S S-W					Unit 2
	31 6	R-BL BL-R					
T3 R3	32 7	R-O O-R					Unit 3
	33 8	R-G G-R					
T4 R4	34 9	R-BR BR-R					Unit 4
	35 10	R-S S-R					
T5 R5	36 11	BK-BL BL-BK					Unit 5
	37 12	BK-S S-BK					
T6 R6	38 13	BK-G G-BK					Unit 6
	39 14	BK-BR BR-BK					
T7 R7	40 15	BK-S S-BK					Unit 7
	41 16	Y-BL BL-Y					

Table 29
NT5K17 Direct Dial Inward Trunk connections for NT8D37 I/O panel connectors B, F, L, S
(Part 2 of 2)

Lead designations	Pins	Pair color	I/O panel connectors				Unit number
			B	F	L	S	
T0 R0	42 17	Y-O O-Y	Slot 2	Slot 6	Slot 10	Slot 14	Unit 0
	43 18	Y-G G-Y					
T1 R1	44 19	Y-BR BR-Y					Unit 1
	45 20	Y-S S-Y					
T2 R2	46 21	V-BL BL-V					Unit 2
	47 22	V-O O-V					
T3 R3	48 23	V-G G-V					Unit 3
	49 24	V-BR BR-V					

Table 30
NT5K17 Direct Dial Inward Trunk connections for NT8D37 I/O panel connectors C, G, M, T
 (Part 1 of 2)

Lead designations	Pins	Pair color	I/O panel connectors				Unit number
			C	G	M	T	
T0 R0	26 1	W-BL BL-W	Slot 2	Slot 6	Slot 10	Slot 14	Unit 4
	27 2	W-O O-W					
T1 R1	28 3	W-G G-W					Unit 5
	29 4	W-BR BR-W					
T2 R2	30 5	W-S S-W					Unit 6
	31 6	R-BL BL-R					
T3 R3	32 7	R-O O-R					Unit 7
	33 8	R-G G-R					

Table 30
NT5K17 Direct Dial Inward Trunk connections for NT8D37 I/O panel connectors C, G, M, T
(Part 2 of 2)

Lead designations	Pins	Pair color	I/O panel connectors				Unit number
			C	G	M	T	
T4 R4	34 9	R-BR BR-R	Slot 3	Slot 7	Slot 11	Slot 15	Unit 0
	35 10	R-S S-R					
T5 R5	36 11	BK-BL BL-BK					Unit 1
	37 12	BK-S S-BK					
T6 R6	38 13	BK-G G-BK					Unit 2
	39 14	BK-BR BR-BK					
T7 R7	40 15	BK-S S-BK					Unit 3
	41 16	Y-BL BL-Y					
T0 R0	42 17	Y-O O-Y					Unit 4
	43 18	Y-G G-Y					
T1 R1	44 19	Y-BR BR-Y					Unit 5
	45 20	Y-S S-Y					
T2 R2	46 21	V-BL BL-V					Unit 6
	47 22	V-O O-V					
T3 R3	48 23	V-G G-V					Unit 7
	49 24	V-BR BR-V					

Table 31
NT5K18 Flexible Central Office Trunk connections for NT8D37 I/O panel
connectors A, E, K, R

Lead designations	Pins	Pair color	I/O panel connectors				Unit number
			A	E	K	R	
T0 R0	26 1	W-BL BL-W	Slot 0	Slot 4	Slot 8	Slot 12	Unit 0
	27 2	W-O O-W					
T1 R1	28 3	W-G G-W					Unit 1
	29 4	W-BR BR-W					
T2 R2	30 5	W-S S-W					Unit 2
	31 6	R-BL BL-R					
T3 R3	32 7	R-O O-R					Unit 3
	33 8	R-G G-R					
T4 R4	34 9	R-BR BR-R					Unit 4
	35 10	R-S S-R					
T5 R5	36 11	BK-BL BL-BK					Unit 5
	37 12	BK-S S-BK					
T6 R6	38 13	BK-G G-BK					Unit 6
	39 14	BK-BR BR-BK					
T7 R7	40 15	BK-S S-BK					Unit 7
	41 16	Y-BL BL-Y					

Table 32
NT5K18 Flexible Central Office Trunk connections for NT8D37 I/O panel
connectors B, F, L, S (Part 1 of 2)

Lead designations	Pins	Pair color	I/O panel connectors				Unit number
			B	F	L	S	
T0 R0	26 1	W-BL BL-W	Slot 1	Slot 5	Slot 9	Slot 13	Unit 0
	27 2	W-O O-W					
T1 R1	28 3	W-G G-W					Unit 1
	29 4	W-BR BR-W					
T2 R2	30 5	W-S S-W					Unit 2
	31 6	R-BL BL-R					
T3 R3	32 7	R-O O-R					Unit 3
	33 8	R-G G-R					
T4 R4	34 9	R-BR BR-R					Unit 4
	35 10	R-S S-R					
T5 R5	36 11	BK-BL BL-BK					Unit 5
	37 12	BK-S S-BK					
T6 R6	38 13	BK-G G-BK					Unit 6
	39 14	BK-BR BR-BK					
T7 R7	40 15	BK-S S-BK					Unit 7
	41 16	Y-BL BL-Y					

Table 32
NT5K18 Flexible Central Office Trunk connections for NT8D37 I/O panel
connectors B, F, L, S (Part 2 of 2)

Lead designations	Pins	Pair color	I/O panel connectors				Unit number
			B	F	L	S	
T0 R0	42 17	Y-O O-Y	Slot 2	Slot 6	Slot 10	Slot 14	Unit 0
	43 18	Y-G G-Y					
T1 R1	44 19	Y-BR BR-Y					Unit 1
	45 20	Y-S S-Y					
T2 R2	46 21	V-BL BL-V					Unit 2
	47 22	V-O O-V					
T3 R3	48 23	V-G G-V					Unit 3
	49 24	V-BR BR-V					

Table 33
NT5K18 Flexible Central Office Trunk connections for NT8D37 I/O panel
connectors C, G, M, T (Part 1 of 2)

Lead designations	Pins	Pair color	I/O panel connectors				Unit number
			C	G	M	T	
T0 R0	26 1	W-BL BL-W	Slot 2	Slot 6	Slot 10	Slot 14	Unit 4
	27 2	W-O O-W					
T1 R1	28 3	W-G G-W					
	29 4	W-BR BR-W					
T2 R2	30 5	W-S S-W					
	31 6	R-BL BL-R					
T3 R3	32 7	R-O O-R					
	33 8	R-G G-R					

Table 33
NT5K18 Flexible Central Office Trunk connections for NT8D37 I/O panel
connectors C, G, M, T (Part 2 of 2)

Lead designations	Pins	Pair color	I/O panel connectors				Unit number
			C	G	M	T	
T4 R4	34 9	R-BR BR-R	Slot 3	Slot 7	Slot 11	Slot 15	Unit 0
	35 10	R-S S-R					
T5 R5	36 11	BK-BL BL-BK					Unit 1
	37 12	BK-S S-BK					
T6 R6	38 13	BK-G G-BK					Unit 2
	39 14	BK-BR BR-BK					
T7 R7	40 15	BK-S S-BK					Unit 3
	41 16	Y-BL BL-Y					
T0 R0	42 17	Y-O O-Y					Unit 4
	43 18	Y-G G-Y					
T1 R1	44 19	Y-BR BR-Y					Unit 5
	45 20	Y-S S-Y					
T2 R2	46 21	V-BL BL-V					Unit 6
	47 22	V-O O-V					
T3 R3	48 23	V-G G-V					Unit 7
	49 24	V-BR BR-V					

Table 34
NT5K19 Flexible E&M 2-Wire Type 1 connections for NT8D37 I/O panel connectors A, E, K, R

Pair	Pins	Pair color	I/O panel connectors				Unit number
			A	E	K	R	
T0 R0	27 2	W-O O-W	Slot 0	Slot 4	Slot 8	Slot 12	Unit 0
E M	28 3	W-G G-W					
T1 R1	31 6	R-BL BL-R					Unit 1
E M	32 7	R-O O-R					
T2 R2	35 10	R-S S-R					Unit 2
E M	36 11	BK-BL BL-BK					
T3 R3	39 14	BK-BR BR-BK					Unit 3
E M	40 15	BK-S S-BK					

Table 35
NT5K19 E&M 2-Wire Type 1 connections for NT8D37 I/O panel connectors B, F, L, S

Pair	Pins	Pair color	I/O panel connectors				Unit number
			A	E	K	R	
T0 R0	27 2	W-O O-W	Slot 1	Slot 5	Slot 9	Slot 13	Unit 0
E M	28 3	W-G G-W					
T1 R1	31 6	R-BL BL-R					Unit 1
E M	32 7	R-O O-R					
T2 R2	35 10	R-S S-R					Unit 2
E M	36 11	BK-BL BL-BK					
T3 R3	39 14	BK-BR BR-BK					Unit 3
E M	40 15	BK-S S-BK					
T0 R0	43 18	Y-G G-Y	Slot 2	Slot 6	Slot 10	Slot 14	Unit 0
E M	44 19	Y-BR BR-Y					
T1 R1	47 22	V-O O-V					Unit 1
E M	48 23	V-G G-V					

Table 36
NT5K19 Flexible E&M 2-Wire Type 1 trunk connections for NT8D37 I/O panel
connectors C, G, M, T

Pair	Pins	Pair color	I/O panel connectors				Unit number
			C	G	M	T	
T2 R2	27 2	W-O O-W	Slot 2	Slot 6	Slot 10	Slot 14	Unit 2
E M	28 3	W-G G-W					
T3 R3	31 6	R-BL BL-R					Unit 3
E M	32 7	R-O O-R	Slot 3	Slot 7	Slot 11	Slot 15	Unit 0
T0 R0	35 10	R-S S-R					
E M	36 11	BK-BL BL-BK					
T1 R1	39 14	BK-BR BR-BK					Unit 1
E M	40 15	BK-S S-BK					
T2 R2	43 18	Y-G G-Y					Unit 2
E M	44 19	Y-BR BR-Y					
T3 R3	47 22	V-O O-V					Unit 3
E M	48 23	V-G G-V					

Table 37
NT5K19 Flexible E&M 2-Wire Paging trunk connections for NT8D37 I/O panel
connectors A, E, K, R

Pair	Pins	Pair color	I/O panel connectors				Unit number
			A	E	K	R	
T0 R0	27 2	W-O O-W	Slot 0	Slot 4	Slot 8	Slot 12	Unit 0
A PG	29 4	W-BR BR-W					
T1 R1	31 6	R-BL BL-R					Unit 1
A PG	33 8	R-G G-R					
T2 R2	35 10	R-S S-R					Unit 2
A PG	37 12	BL-O O-BL					
T3 R3	39 14	BK-BR BR-BK					Unit 3
A PG	41 16	Y-BL BL-Y					

Table 38
NT5K19 Flexible E&M 2-Wire Paging trunk connections for NT8D37 I/O panel
connectors B, F, L, S

Pair	Pins	Pair color	I/O panel connectors				Unit number
			B	F	L	S	
T0 R0	27 2	W-O O-W	Slot 1	Slot 5	Slot 9	Slot 13	Unit 0
A PG	29 4	W-BR BR-W					
T1 R1	31 6	R-BL BL-R					Unit 1
A PG	33 8	R-G G-R					
T2 R2	35 10	R-S S-R					Unit 2
A PG	37 12	BL-O O-BL					
T3 R3	39 14	BK-BR BR-BK					Unit 3
A PG	41 16	Y-BL BL-Y					
T0 R0	43 18	Y-G G-Y	Slot 2	Slot 6	Slot 10	Slot 14	Unit 0
A PG	45 20	Y-S S-Y					
T1 R1	47 22	V-O O-V					Unit 1
A PG	49 24	V-BR BR-V					

Table 39
NT5K19 Flexible E&M 2-Wire Paging trunk connections for NT8D37 I/O panel
connectors C, G, M, T

Pair	Pins	Pair color	I/O panel connectors				Unit number
			C	G	M	T	
T2 R2	27 2	W-O O-W	Slot 2	Slot 6	Slot 10	Slot 14	Unit 2
A PG	29 4	W-BR BR-W					
T3 R3	31 6	R-BL BL-R					Slot 3
A PG	33 8	R-G G-R					
T0 R0	35 10	R-S S-R	Slot 3	Slot 7	Slot 11	Slot 15	
A PG	37 12	BL-O O-BL					
T1 R1	39 14	BK-BR BR-BK					Slot 3
A PG	41 16	Y-BL BL-Y					
T2 R2	43 18	Y-G G-Y	Slot 3	Slot 7	Slot 11	Slot 15	
A PG	45 20	Y-S S-Y					
T3 R3	47 22	V-O O-V					Slot 3
A PG	49 24	V-BR BR-V					

Table 40
NT5K19 Flexible E&M 2-Wire Recorded Announcement trunk connections for NT8D37 I/O panel connectors A, E, K, R

Pair	Pins	Pair color	I/O panel connectors				Unit number
			A	E	K	R	
T0 R0	26 1	W-BL BL-W	Slot 0	Slot 4	Slot 8	Slot 12	Unit 0
SIG B SIG A	29 4	W-BR BR-W					
T1 R1	30 5	W-S S-W					Unit 1
SIG B SIG A	33 8	R-G G-R					
T2 R2	34 9	R-BR BR-R					Unit 2
SIG B SIG A	37 12	BL-O O-BL					
T3 R3	38 13	BK-G G-BK					Unit 3
SIG B SIG A	41 16	Y-BL BL-Y					

Table 41
NT5K19 Flexible E&M 2-Wire Recorded Announcement trunk connections for NT8D37 I/O panel connectors B, F, L, S

Pair	Pins	Pair color	I/O panel connectors				Unit number
			B	F	L	S	
T0 R0	26 1	W-BL BL-W	Slot 1	Slot 5	Slot 9	Slot 13	Unit 0
SIG B SIG A	29 4	W-BR BR-W					
T1 R1	30 5	W-S S-W					Unit 1
SIG B SIG A	33 8	R-G G-R					
T2 R2	34 9	R-BR BR-R					Unit 2
SIG B SIG A	37 12	BL-O O-BL					
T3 R3	38 13	BK-G G-BK					Unit 3
SIG B SIG A	41 16	Y-BL BL-Y					
T0 R0	42 17	Y-O O-Y	Slot 2	Slot 6	Slot 10	Slot 14	Unit 0
SIG B SIG A	45 20	Y-S S-Y					
T1 R1	46 21	V-BL BL-V					Unit 1
SIG B SIG A	49 24	V-BR BR-V					

Table 42
NT5K19 Flexible E&M 2-Wire Recorded Announcement trunk connections for NT8D37 I/O
panel connectors C, G, M, T

Pair	Pins	Pair color	I/O panel connectors				Unit number
			C	G	M	T	
T2 R2	26 1	W-BL BL-W	Slot 2	Slot 6	Slot 10	Slot 14	Unit 2
SIG B SIG A	29 4	W-BR BR-W					
T3 R3	30 5	W-S S-W					Unit 3
SIG B SIG A	33 8	R-G G-R					
T0 R0	34 9	R-BR BR-R	Slot 3	Slot 7	Slot 11	Slot 15	
SIG B SIG A	37 12	BL-O O-BL					
T1 R1	38 13	BK-G G-BK					Unit 1
SIG B SIG A	41 16	Y-BL BL-Y					
T2 R2	42 17	Y-O O-Y					Unit 2
SIG B SIG A	45 20	Y-S S-Y					
T3 R3	46 21	V-BL BL-V					Unit 3
SIG B SIG A	49 24	V-BR BR-V					

Table 43
NT5K19 Flexible E&M 4-Wire Type 1 connections for NT8D37 I/O panel connectors A, E, K, R

Lead designations	Pins	Pair color	I/O panel connectors				Unit number
			A	E	K	R	
TA TB	26 1	W-BL BL-W	Slot 0	Slot 4	Slot 8	Slot 12	Unit 0
RA RB	27 2	W-O O-W					
E M	28 3	W-G G-W					
TA TB	30 5	W-S S-W					Unit 1
RA RB	31 6	R-BL BL-R					
E M	32 7	R-O O-R					
TA TB	34 9	R-BR BR-R					Unit 2
RA RB	35 10	R-S S-R					
E M	36 11	BK-BL BL-BK					
TA TB	38 13	BK-G G-BK					Unit 3
RA RB	39 14	BK-BR BR-BK					
E M	40 15	BK-S S-BK					

Note: The cable pair designated TA, TB is the transmit pair. The pair designated RA, RB is the receive pair.

Table 44
NT5K19 Flexible E&M 4-Wire Type 1 connections for NT8D37 I/O panel connectors B, F, L, S
(Part 1 of 2)

Lead designations	Pins	Pair color	I/O panel connectors				Unit number
			B	F	L	S	
TA TB	26 1	W-BL BL-W	Slot 1	Slot 5	Slot 9	Slot 13	Unit 0
RA RB	27 2	W-O O-W					
E M	28 3	W-G G-W					
TA TB	30 5	W-S S-W					Unit 1
RA RB	31 6	R-BL BL-R					
E M	32 7	R-O O-R					
TA TB	34 9	R-BR BR-R					Unit 2
RA RB	35 10	R-S S-R					
E M	36 11	BK-BL BL-BK					
TA TB	38 13	BK-G G-BK					Unit 3
RA RB	39 14	BK-BR BR-BK					
E M	40 15	BK-S S-BK					

Note: The cable pair designated TA, TB is the transmit pair. The pair designated RA, RB is the receive pair.

Table 44
NT5K19 Flexible E&M 4-Wire Type 1 connections for NT8D37 I/O panel connectors B, F, L, S
(Part 2 of 2)

Lead designations	Pins	Pair color	I/O panel connectors				Unit number
Type 1 mode			B	F	L	S	
TA TB	42 17	Y-O O-Y	Slot 2	Slot 6	Slot 10	Slot 14	Unit 0
RA RB	43 18	Y-G G-Y					
E M	44 19	Y-BR BR-Y					
TA TB	46 21	V-BL BL-V					
RA RB	47 22	V-O O-V					Unit 1
E M	48 23	V-G G-V					

Note: The cable pair designated TA, TB is the transmit pair. The pair designated RA, RB is the receive pair.

Table 45
NT5K19 Flexible E&M AC15 trunk connections for NT8D37 I/O panel connectors A, E, K, R

Lead designations	Pins	Pair color	I/O panel connectors				Unit number
			A	E	K	R	
TA TB	26 1	W-BL BL-W	Slot 0	Slot 4	Slot 8	Slot 12	Unit 0
RA RB	27 2	W-O O-W					
TA TB	30 5	W-S S-W					Unit 1
RA RB	31 6	R-BL BL-R					
TA TB	34 9	R-BR BR-R					Unit 2
RA RB	35 10	R-S S-R					
TA TB	38 13	BK-G G-BK					Unit 3
RA RB	39 14	BK-BR BR-BK					

Note: The cable pair designated TA, TB is the transmit pair. The pair designated RA, RB is the receive pair.

Table 46
NT5K19 Flexible E&M AC15 Trunk connections for NT8D37 I/O panel connectors B, F, L, S

Lead designations	Pins	Pair color	I/O panel connectors				Unit number				
			B	F	L	S					
TA TB	26 1	W-BL BL-W	Slot 1	Slot 5	Slot 9	Slot 13	Unit 0				
RA RB	27 2	W-O O-W					Unit 1				
TA TB	30 5	W-S S-W					Unit 2				
RA RB	31 6	R-BL BL-R					Unit 3				
TA TB	34 9	R-BR BR-R									
RA RB	35 10	R-S S-R									
TA TB	38 13	BK-G G-BK									
RA RB	39 14	BK-BR BR-BK									
TA TB	42 17	Y-O O-Y					Slot 2	Slot 6	Slot 10	Slot 14	Unit 0
RA RB	43 18	Y-G G-Y									Unit 1
TA TB	46 21	V-BL BL-V									
RA RB	47 22	V-O O-V									

Note: The cable pair designated TA, TB is the transmit pair. The pair designated RA, RB is the receive pair.

Powering up the system and initial loading

Content list

The following are the topics in this section:

Reference list	222
Power up Option 81C AC systems	222
Install the Security Device	222
Prepare for power up 81C	222
Connect the 81C AC power source	223
Turn 81C AC power ON	225
Reset the main circuit breakers (AC power)	226
Power up Option 81C DC systems	227
Install the Security Device	227
Prepare for power up	227
Turn 81C DC power ON	230
Install the Option 81C software on Core/Net 1	231
Install software on Core/Net 0	236
Test Core/Net 1 and Core/Net 0	241
Install the customer database	242
Preparing for power-up for 51C and 61C	242
Connecting power for AC-powered systems for 51C and 61C	243
Connecting power for DC-powered systems for 51C and 61C	245

Reference list

The following are the references in this section:

- *Installation Planning* (553-3001-120)
- *Telephone and Attendant Console: Installation* (553-3001-215)
- *M3900 Series Meridian Digital Telephones: Description, Installation, and Administration* (553-3001-216)
- *Administration* (553-3001-311)
- *Hardware Upgrade Procedures* (553-3001-258)

This section describes how to power up and initialize an Option 51C, 61C, or 81C and install new software.

Power up Option 81C AC systems

Install the Security Device

The Security Device (Figure 98 on page 223) resembles a large watch battery and is shipped with the software package. This device, along with the Keycode Installation diskette, enables the features for each individual system.

The Security Device is inserted into the Security Device holder. This assembly is attached to the back of the System Utility Transition card (Figure 99 on page 224).

- 1 Verify that the 8-digit code on the Keycode Installation diskette matches the 8-digit code on the Device.
- 2 Insert the Security Device into the holder with the "Nortel" side facing up. Do not bend the clip more than necessary.
- 3 Insert the assembly (Device and holder) into the back of the System Utility Transition card in both Core/Net modules (Figure 99 on page 224).
- 4 Verify that the Security Device is securely in place.

Prepare for power up 81C

- 1 Verify that all power breakers and switches are turned OFF:
 - a. Set the AC service panel circuit breakers OFF.

Figure 98
Security Device and holder

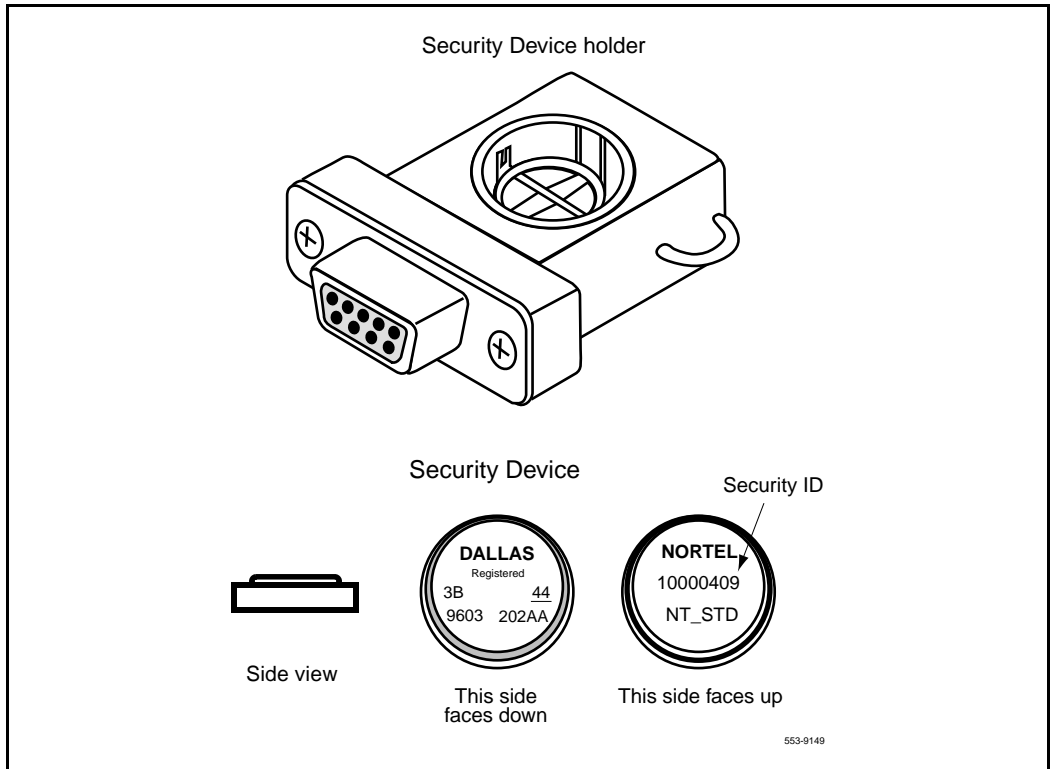

- b. Set the main circuit breakers in the rear of each pedestal OFF.
 - c. Set the power supply or MPDU switches in each module OFF.
 - d. Set the ringing generators in each IPE or PE module OFF.
 - e. Set the blower unit switch in the front of each pedestal OFF.
- 2 Set all faceplate switches to ENB.

Connect the 81C AC power source

The Meridian 1 system can be connected to the AC power source with one of the two options below:

Figure 99
Security Device installation (System Utility Transition card)

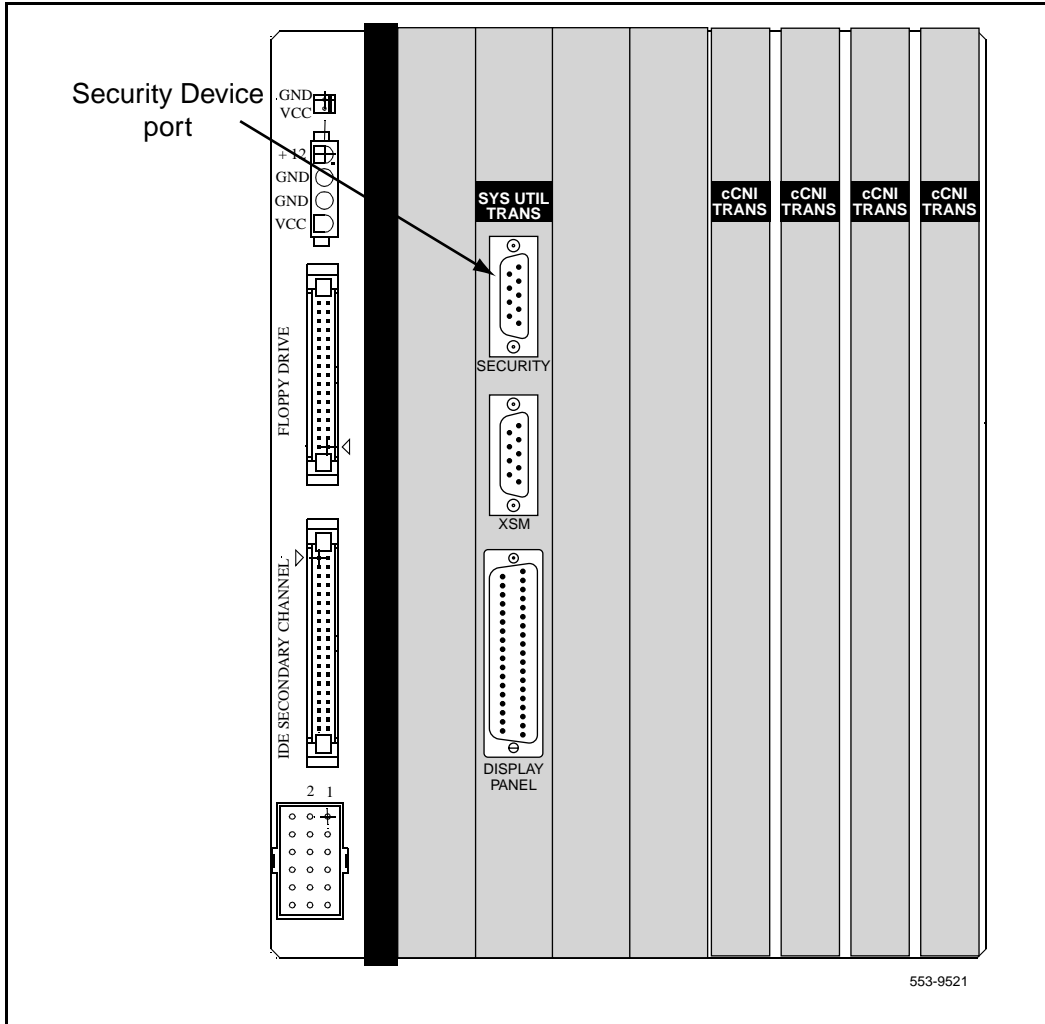

Option 1: Use the installed power plug (recommended)

Each column can be directly connected to the AC power source.

- 1 Connect the power plug from each column to the AC power receptacle.
- 2 Proceed to “Turn 81C AC power ON” on page 225.

Option 2: Hard-wire the power connections (optional)

Instead of using the power-plug, each column can be hard-wired to the service panel.

- 1 Route three #10 AWG wires (green, white and black) through 3/4 in. conduit from the service panel to each Meridian 1 column.
- 2 At the column, connect the wires to the field wiring access block of the PDU according to the following:
 - GND (ground) to the green wire
 - L2 (neutral) to the white wire
 - L1(hot) to the black wire
- 3 Connect the wires to the hot, neutral and ground connections at the service panel.
- 4 Proceed to “Turn 81C AC power ON” on page 225.

Turn 81C AC power ON**CAUTION****System Failure**

If a problem occurs when a step is performed, resolve that problem before continuing.

- 1 In the AC power panel, set the circuit breaker for Column 0 to ON.
- 2 Set the main circuit breaker for Column 0 to ON (rear of the pedestal).
- 3 Set the blower unit switch for Column 0 to ON. On initial power-up, the blower will rotate slowly. As the system heats up, the cooling fans will turn faster.
- 4 Set the main circuit breaker for Column 0 to ON. The main circuit breaker is located in the rear of the pedestal.

- 5 Set the power supply switch (or MPDU circuit breaker) in each module to ON. The green light will turn on after a few seconds.
Note: If the module is equipped with a ringing generator, set the breakers or switches for both the power supply and the ringing generator to ON. The green LED on a ringing generator normally takes up to 90 seconds to light.
- 6 Repeat steps 1 through 5 for each column in the system. Start with Column 1 and continue until power is turned on in all the columns. Make sure the green lights in all the module power supplies are lit before proceeding to the next column.
- 7 When the green LED lights in all module power supplies and ringing generators are lit, proceed to “Reset the main circuit breakers (AC power)” on page 226.

Reset the main circuit breakers (AC power)

- 1 Turn the main circuit breakers in the pedestal of each column OFF again.
- 2 Wait 30 seconds.
- 3 Set the main circuit breakers for NON-CORE columns ON. Leave the Core columns OFF.
- 4 For each non-Core column, verify that:
 - the main circuit breaker in the pedestal did not trip OFF
 - the main blower unit in each column is running
 - the ringing generators are lit
 - the red column LEDs in the top cap are lit. These LEDs will remain red until the system reloads.
- 5 Simultaneously turn the main circuit breakers for the two Core columns ON.
- 6 For each Core column, verify the following:
 - the main circuit breaker in the pedestal did not trip OFF
 - the main blower unit in each column is running
 - the ringing generators are lit
 - the red column LEDs in the top cap are lit. These LEDs will remain red until the system reloads.

- 7 When the system is running, reattach all covers and panels to the modules and columns. Module covers must be kept on so the air from the pedestal fans will be directed up through all the modules and out the exhaust vents in the top cap. When the module covers are removed, the upper modules are not cooled properly because the air escapes from the open module door.

If the module covers are left off and the system overheats, circuit cards will malfunction and, in extreme cases, melt.

Power up Option 81C DC systems

Install the Security Device

The Security Device (Figure 100 on page 228) resembles a large watch battery and is shipped with the software package. This device, along with the Keycode Installation diskette, enables the features for each individual system.

The Security Device is inserted into the Security Device holder. This assembly is attached to the back of the System Utility Transition card (Figure 101 on page 229).

- 1 Verify that the 8-digit code on the Keycode Installation diskette matches the 8-digit code on the Device.
- 2 Insert the Security Device into the holder with the "Nortel" side facing up. Do not bend the clip more than necessary.
- 3 Insert the assembly (Device and holder) into the back of the System Utility Transition card in both Core/Net modules (Figure 101 on page 229).
- 4 Verify that the Security Device is securely in place.

Prepare for power up

- 1 Verify that all power breakers and switches are turned OFF:
 - Set the AC service panel circuit breakers to each rectifier OFF.
 - Remove the DC power distribution fuses or set the distribution circuit breakers OFF.
 - Set all circuit breakers in the rear of each pedestal OFF.
 - Set the power supply switches in each module OFF.
 - Set the ringing generators in each IPE or PE module OFF.
 - Set the blower unit in each pedestal OFF.

Figure 100
Security Device and holder

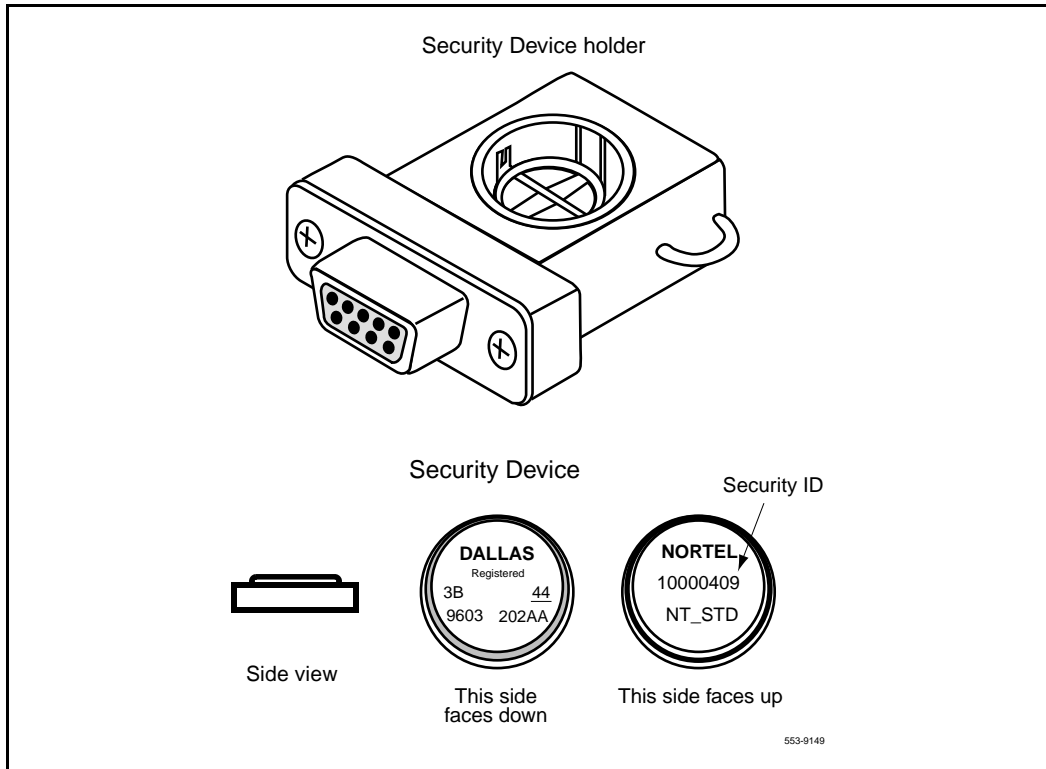

- 2 Set all faceplate switches to ENB.
- 3 Proceed to "Turn 81C DC power ON" on page 230.

Figure 101
Security Device installation (System Utility Transition card)

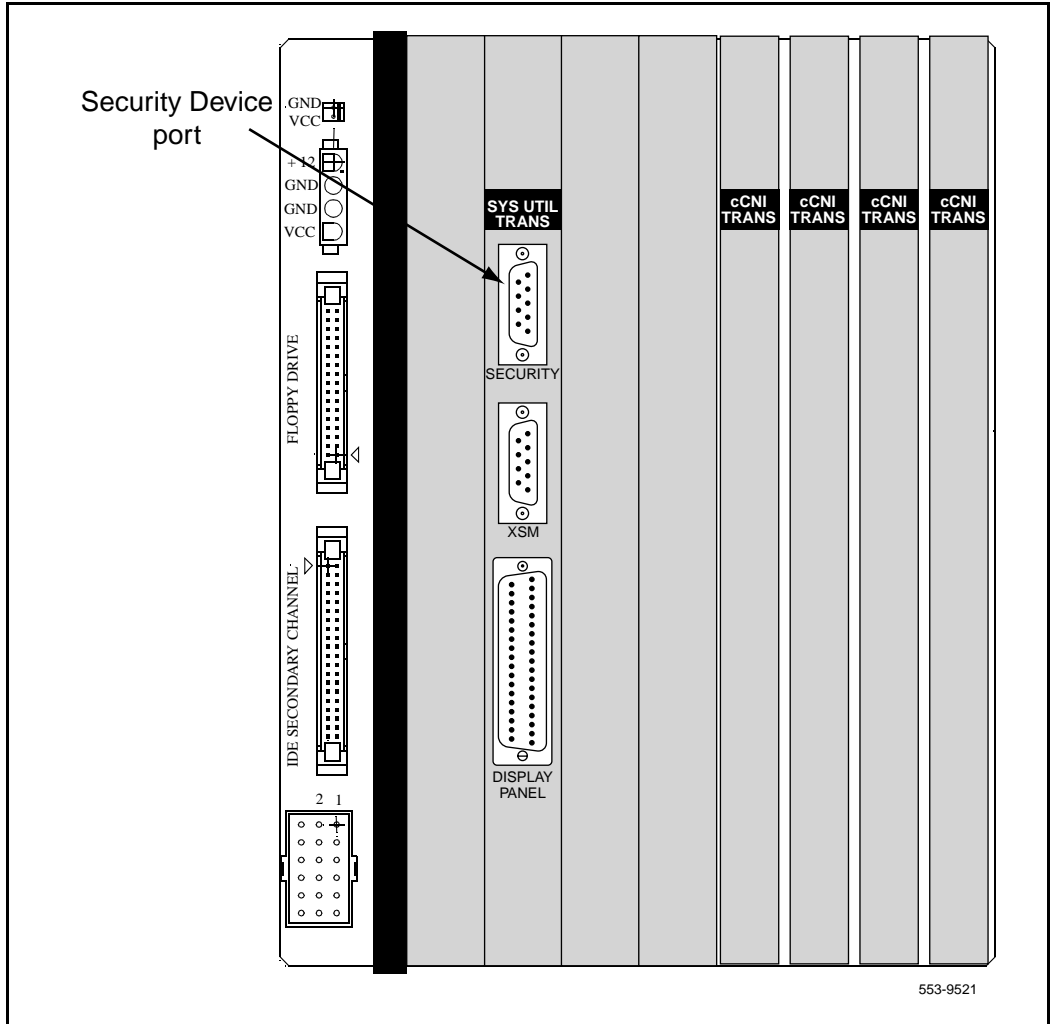

Turn 81C DC power ON

- 1 Connect each DC rectifier to its associated AC outlet and set the breakers in the AC power panel to ON.
- 2 Turn the rectifiers ON one at a time. Wait 10 seconds between each rectifier.



CAUTION

System Failure

If a problem occurs in any of the following steps, resolve that problem before continuing.

Perform the following tasks for each column.

Note: Power up the Core columns last.

- 3 On the DC power source for each column, replace the distribution fuses or set the distribution breakers to ON. Do the Core columns last.
- 4 Set the blower unit breaker switch ON (the far left breaker in the rear of the pedestal).
- 5 Set the blower unit switch in the front of the pedestal to ON. Verify that the fan is running. On initial power-up, the blower will rotate slowly. As the system heats up, the cooling fans will turn faster.
- 6 Set the power supply switch in each module to ON. The green light will turn on after a few seconds.
Note: If the module is equipped with a ringing generator, set the breakers or switches for both the power supply and the ringing generator to ON. The green LED on a ringing generator normally takes up to 90 seconds to light.
- 7 Repeat steps 1 through 5 for each column in the system. Start with Column 2 and continue until power is turned on in all the columns. Do the Core columns last.
- 8 Make sure the green lights in all the module power supplies are lit before proceeding to the next column. The red LED for each column remains lit until the system reloads.

- 9 Once the system is running, reattach all covers and panels to the modules and columns. Module covers must be kept on so the air from the pedestal fans will be directed up through all the modules and out the exhaust vents in the top cap. When the module covers are removed, the upper modules are not cooled properly because the air escapes from the open module door.

If the module covers are left off and the system overheats, circuit cards will malfunction and, in extreme cases, melt.

Install the Option 81C software on Core/Net 1

- 1 Install the CD-ROM into the CD-ROM drive in the MMDU:
- Press the button on the CD-ROM drive to open the CD-ROM disk holder.
 - Place the CD-ROM disk into the holder with the disk label showing. Use the four tabs to secure the CD-ROM drive.
 - Press the button again to close the CD-ROM disk holder.
Do not push the holder in by hand.

Note: If the CD-ROM is not in the CD-ROM drive, the installation will not continue. Insert the CD-ROM to continue.

- 2 Place the CP PII Install floppy disk into the MMDU floppy drive.

Note: If a problem is detected during the system verification, Install stops, prints an error message, and aborts the installation. If the verification is not successful, do not continue; contact your technical support organization.

- 3 Press the RESET button on CP PII. Before the Install menu runs, the system validates hard disk partitioning which takes about five minutes. The screen displays:

Testing partition 0

0 percent done...1 percent done.....99 percent done....100
percent done

Testing partition 1

0 percent done...1 percent done.....99 percent done....100
percent done

Testing partition 2

0 percent done...1 percent done.....99 percent done....100 percent completed!

Disk physical checking is completed!

There are 3 partitions in disk 0:

The size of partition 0 of disk 0 is XX MB

The size of partition 0 of disk 0 is XX MB

The size of partition 0 of disk 0 is XX MB

Disk partitions and sectors checking is completed!

- 4 Press <cr> to start the software installation.
- 5 When prompted, remove the CP PII Install Program diskette and insert the Keycode diskette.
 - <a> Continue with keycode validation.
 - <y> Confirm that the keycode matches the CD-ROM release.
- 6 When the screen displays the Install Menu, select the following options in sequence when you are prompted to do so:
 - <a> Install software.
 - <a> Verify that the CD-ROM is now in drive.The Installation Status Summary screen appears that lists the options to be installed.
 - <y> Start Installation.
 - <a> Continue with Upgrade.

Pre-release 3 language groups

- 7 Select a PSDL file to install. The PSDL file contains the loadware for all downloadable cards in the system and loadware for M3900 series sets.

Select one of the six PSDL files

- <1> Global 10 Languages
- <2> Western Europe 10 Languages
- <3> Eastern Europe 10 Languages
- <4> North America 6 Languages
- <5> Spare Group A
- <6> North America 6 Languages (Duplicate of <4>)

The languages contained in each selection are outlined as follows:

- 1 - English, French, German, Spanish, Swedish, Italian, Norwegian, Brazilian Portuguese, Finnish, Japanese Katakana.
- * 2 - English, French, German, Spanish, Swedish, Norwegian, Danish, Finnish, Italian, Brazilian Portuguese.
- * 3 - English, French, German, Dutch, Polish, Czech, Hungarian, Russian, Latvian, Turkish.
- * 4 - English, Spanish, French, Brazilian Portuguese, Japanese Katakana, German.
- * 5 - English, French, German, Spanish, Swedish, Italian, Norwegian, Portuguese, Finnish, Japanese Katakana.
- * 6 - English, Spanish, French, Brazilian Portuguese, Japanese Katakana, German.

Release 3 language groups

- 8 Select a PSDL file to install. The PSDL file contains the loadware for all downloadable cards in the system and loadware for M3900 series sets.

Select one of the six PSDL files

- <1> Global 10 Languages
- <2> Western Europe 10 Languages
- <3> Eastern Europe 10 Languages
- <4> North America 6 Languages
- <5> Spare Group A
- <6> North America 6 Languages (Duplicate of <4>)

The languages contained in each selection are outlined as follows:

- 1 – Global 10 Languages (Release 3) English, French, German, Spanish, Swedish, Italian, Norwegian, Brazilian Portuguese, Finnish, Japanese Katakana.
- 2 – Western Europe 10 Languages (Release 3) English, French, German, Spanish, Swedish, Italian, Norwegian, Brazilian Portuguese, Finnish, Danish.
- 3 – Eastern Europe 10 Languages (Release 3) English, French, German, Dutch, Polish, Czech, Hungarian, Russian, Latvian, Turkish.
- 4 – North America six Languages (Release 3) English, French, German, Spanish, Brazilian Portuguese, Japanese Katakana.
- 5 – Spare Group A.
- 6 – Spare Group B.

- 9** Continue with ROM upgrade when prompted.
Select a database to install.
- <cr>** Enter carriage return to continue.
 - <a>** Continue with CP BOOTROM installation.
 - <a>** Install the CP BOOTROM from hard disk.
 - <a>** Start installation.
 - <a>** Continue with ROM upgrade.
- The Installation Status Summary screen appears. Verify that CD to disk, disk to ROM, and CP-BOOTROM were installed.
- <cr>** Continue.
 - <q>** Quit.
Remove any diskettes and the CD-ROM from the MMDU drives.
 - <y>** Confirm quit.
 - <a>** Reboot the system.
- 10** The system automatically performs a sysload: several message appear on the system terminal. Wait for "DONE" and then "INI" message to display before you continue.
- 11** Confirm that X11 Release 25 software is installed and working on Core/Net 1:
- LD 135** Load the program.
 - STAT CPU** Display the CPU status.
 - STAT CNI** Display the cCNI status.

Check for peripheral software download

Load LD 22 and print the software version.

LD 22

- REQ** Print.
- TYPE** PSWV.
- ISSP** Print issue and release.
- TID** Print Tape ID.
- SLLP** Print System and patch information.
Print auxiliary ID.
- ****** Exit program.

Install software on Core/Net 0

- 1 Install the CD-ROM into the CD-ROM drive in the MMDU:
 - a. Press the button on the CD-ROM drive to open the CD-ROM disk holder.
 - b. Place the CD-ROM disk into the holder with the disk label showing.
 - c. Press the button again to close the CD-ROM disk holder.
Do not push the holder in by hand.

Note: If the CD-ROM is not in the CD-ROM drive, the installation will not continue. Insert the CD-ROM to continue.

- 2 Place the CP PII Install floppy disk into the MMDU floppy drive.

Note: If a problem is detected during the system verification, Install stops, prints an error message, and aborts the installation. If the verification is not successful, do not continue; contact your technical support organization.

- 3 Press the manual RESET button on the CP PII card faceplate. Before the Install menu runs, the system validates hard disk partitioning which takes about five minutes. The screen displays:

Testing partition 0

0 percent done 0 percent done...1 percent done 1 percent done...99 percent done...99 percent done....100 percent done....100 percent done

Testing partition 1

0 percent done 0 percent done...1 percent done 1 percent done...99 percent done...99 percent done....100 percent done....100 percent done

Testing partition 2

0 percent done 0 percent done...1 percent done 1 percent done...99 percent done...99 percent done....100 percent done....100 percent completed!

Disk physical checking is completed!

There are 3 partitions in disk 0:
The size of partition 0 of disk 0 is XX MB
The size of partition 0 of disk 0 is XX MB
The size of partition 0 of disk 0 is XX MB
Disk partitions and sectors checking is competed!

- 4 At the terminal, press <cr> to start the software installation.
- 5 When prompted, remove the CP PII Install Program diskette and insert the Keycode diskette.
 - <a> Continue with keycode validation
 - <y> Confirm that the keycode matches the CD-ROM release
- 6 When the screen displays the Install Menu, select the following options in sequence when you are prompted to do so:
 - <a> Install software.
 - <a> Verify that the CD-ROM is now in drive.
The Installation Status Summary screen appears that lists the options to be installed.
 - <y> Start Installation.
 - <a> Continue with Upgrade.

Pre-release 3 language groups

- 7 Select a PSDL file to install. The PSDL file contains the loadware for all downloadable cards in the system and loadware for M3900 series sets.

Select one of the six PSDL files

- <1> Global 10 Languages
- <2> Western Europe 10 Languages
- <3> Eastern Europe 10 Languages
- <4> North America 6 Languages
- <5> Spare Group A
- <6> North America 6 Languages (Duplicate of <4>)

The languages contained in each selection are outlined as follows:

- 1 - English, French, German, Spanish, Swedish, Italian, Norwegian, Brazilian Portuguese, Finnish, Japanese Katakana.
- * 2 - English, French, German, Spanish, Swedish, Norwegian, Danish, Finnish, Italian, Brazilian Portuguese.
- * 3 - English, French, German, Dutch, Polish, Czech, Hungarian, Russian, Latvian, Turkish.
- * 4 - English, Spanish, French, Brazilian Portuguese, Japanese Katakana, German.
- * 5 - English, French, German, Spanish, Swedish, Italian, Norwegian, Portuguese, Finnish, Japanese Katakana.
- * 6 - English, Spanish, French, Brazilian Portuguese, Japanese Katakana, German.

Release 3 language groups

- 8** Select a PSDL file to install. The PSDL file contains the loadware for all downloadable cards in the system and loadware for M3900 series sets.

Select one of the six PSDL files

- <1> Global 10 Languages
- <2> Western Europe 10 Languages
- <3> Eastern Europe 10 Languages
- <4> North America 6 Languages
- <5> Spare Group A
- <6> North America 6 Languages (Duplicate of <4>)

The languages contained in each selection are outlined as follows:

- 1 – Global 10 Languages (Release 3) English, French, German, Spanish, Swedish, Italian, Norwegian, Brazilian Portuguese, Finnish, Japanese Katakana.
- 2 – Western Europe 10 Languages (Release 3) English, French, German, Spanish, Swedish, Italian, Norwegian, Brazilian Portuguese, Finnish, Danish.
- 3 – Eastern Europe 10 Languages (Release 3) English, French, German, Dutch, Polish, Czech, Hungarian, Russian, Latvian, Turkish.
- 4 – North America six Languages (Release 3) English, French, German, Spanish, Brazilian Portuguese, Japanese Katakana.
- 5 – Spare Group A.
- 6 – Spare Group B.

- 9 Continue with ROM upgrade when prompted.
Select a database to install.
- <cr> Enter carriage return to continue.
 - <a> Continue with CP BOOTROM installation.
 - <a> Install the CP BOOTROM from hard disk.
 - <a> Start installation.
 - <a> Continue with ROM upgrade.
- The Installation Status Summary screen appears. Verify that CD to disk, disk to ROM, and CP-BOOTROM were installed.
- <cr> Continue.
 - <q> Quit (remove any diskettes and the CD-ROM from the MMDU drives).
 - <y> Confirm quit.
 - <a> Reboot the system.
- 10 The system automatically performs a sysload: several message appear on the system terminal. Wait for "DONE" and then "INI" message to display before you continue.
- 11 Confirm that X11 Release 25 software is installed and working on Core/Net 0:
- LD 135** Load the program.
 - STAT CPU** Display the CPU status.
 - STAT CNI** Display the cCNI status.
- 12 Press the INIT button on the CP PII card of Core/Net 0 to place the system into the full redundant mode.

Check for peripheral software download

Load LD 22 and print the software version..

LD 22

- REQ** PRT
- TYPE** PSWV
- ISSP** Print issue and release.
- TID** Print Tape ID.
- SLLP** Print System and patch information.

Print auxiliary ID.
**** Exit program.

Test Core/Net 1 and Core/Net 0

From the active CPU, Core/Net 1, perform these tests:

- 1 Perform a redundancy sanity test using the following sequence:

LD 135

STAT CNI c s Get status of cCNI cards.
STAT CPU Get status of CPU and memory.
TEST CPU Test the CP PII card in both Core/Nets.
TEST CNI c s Test each cCNI card (core, slot).
STAT SUTL Get status of System Utility (main and Transition) cards.
TEST SUTL Test the System Utility (main and Transition) cards.
TEST IPB Test the Inter Processor Bus
TEST LCD Test the LCDs.
TEST LED Test the LEDs.

- 2 Test system redundancy:

LD 137

TEST RDUN Test redundancy.
DATA RDUN
TEST CMDU Test the MMDU card.

- 3 Switch Cores and test the other side (Core/Net 0)

LD 135

SCPU Switch cores.
TEST CPU Test the inactive Core/Net.
STAT CNI c s Get status of cCNI (both main and Transition) cards.
TEST CNI c s Test cCNI (both main and Transition) cards.
STAT SUTL Get status of System Utility card.
TEST SUTL Test System Util card.

- | | | |
|---|---------------------|--|
| | TEST IPB | Test Inter Processor Bus. |
| | TEST LCD | Test LCDs. |
| | TEST LED | Test LEDs |
| 4 | | Clear the display and minor alarms on both Cores. |
| | CDSP | Clear the displays on the Cores. |
| | CMAJ | Clear major alarms. |
| | CMIN ALL | Clear minor alarms. |
| 5 | | Get the status of the Cores, CNIs, and memory. |
| | STAT CPU | Get the status of both Cores and redundancy |
| | STAT CNI c s | Get the status of all configured cCNIs (both main and Transition) cards. |
| | **** | Exit program. |

Install the customer database

Use the administration overlays in the *Administration* (553-3001-311), and the procedures outlined in the following:

- *Telephone and Attendant Console: Installation* (553-3001-215)
- *M3900 Series Meridian Digital Telephones: Description, Installation, and Administration* (553-3001-216)
- appropriate NTPs for other features

Preparing for power-up for 51C and 61C

- 1 Locate the Keycode Installation diskette that corresponds with the Call Processor (CP) card installed in your system.
- 2 Locate the round 1/2" diameter Security Device for the NT5D61 Input Output Disk Unit with CD-ROM (IODU/C) card.
- 3 Make sure that the 8-digit code on the Keycode Installation diskette matches the 8-digit code on the Security Device.

- 4 Install the Security Device on the IODU/C card:
 - With the Nortel side facing upward, slide the Security Device between the black round security device holder on the top right hand corner of the IODU/C card and the holder clip. Do not bend the clip more than necessary when inserting the Security Device.
 - Ensure that the Security Device is securely in place.
 - In a dual CPU system, install a Security Device for both CPUs
- 5 Install the IODU/C card(s) into slots 17, 18, and 19.
- 6 Lock the locking devices by pushing them gently towards the faceplate. Set the ENB/DIS switch to ENB.
- 7 Verify that all cards are locked into their assigned slots.
- 8 Verify that all cable connectors are secured.
- 9 Set all circuit breakers to OFF.
- 10 Set all faceplate switches to ENB.
- 11 Set CPUs for normal operation.
 - **For Option 51C**, set the NORM/MAINT switch on the CP card to MAINT.
 - **For Options 61C and 81C**, set the NORM/MAINT switch for both CP cards to NORM.

Connecting power for AC-powered systems for 51C and 61C

- 1 Test the commercial power source for proper voltage (see *Installation Planning* (553-3001-120) for voltage requirements).
- 2 Set the main circuit breaker in the rear of each pedestal to OFF.
- 3 Set the circuit breakers on each MPDU, or the switch on each module power supply, to OFF in each module.
- 4 Set the circuit breaker on the blower unit in the front of each pedestal to OFF.
- 5 Connect the AC power cord for each pedestal to its associated commercial power outlet.

Note: If a problem is found in any of the following steps, resolve that problem before continuing.

6 If not already done, in the power panel set the circuit breaker that provides service for Column 0 to ON.

7 Set the main circuit breaker in Column 0 to ON.

8 Set the circuit breaker on the blower unit in Column 0 to ON. You should hear the blower running.

Note: On initial power-up, the blower may rotate slower than expected. As the sensor detects heat, the blower will rotate faster.

9 Set the circuit breaker on the MPDU, or the switch on the module power supply, to ON in Module 0. After a few seconds, the green LED on the power supply should light.

Repeat this step for each module in the column, one module at a time. (If the module is equipped with a ringing generator, set the breakers or switches for both the power supply and the ringing generator to ON.)

Note: It may take up to 90 seconds for the green LED to light on a ringing generator. This is normal operation.

10 Repeat steps 5 through 9 for each column.

11 Once the green LED is lit on all module power supplies and ringing generators, set the main circuit breaker for each column to OFF, wait at least 30 seconds, then set the breaker back to ON (leave CPU columns off).

- The breaker should not trip. The blower unit in each column should be running and the green LED on all module power supplies and ringing generators should be lit. All red column LEDs should also be lit.
- Set the main circuit breakers for the CPU columns to ON (in dual Core systems, set the breakers simultaneously).

At this point, all blower units should be running and the green LED on all module power supplies and ringing generators should be lit. The red column LEDs will remain lit until the system reloads

Connecting power for DC-powered systems for 51C and 61C

Use the following procedure to power up Option 51C and 61C:

- 1 Set the main AC circuit breaker to each rectifier to OFF.
- 2 For each rectifier, test the commercial power source for proper voltage (see *Installation Planning* (553-3001-120) for voltage requirements).
- 3 Remove all distribution fuses, or set all distribution breakers to OFF, on the DC power source for each column.
- 4 Set all circuit breakers in the rear of each pedestal to OFF.
- 5 Set the switch on each module power supply and ringing generator to OFF.
- 6 Set the switch on the blower unit in the front of each pedestal to OFF.

Note 1: If a problem is found in any of the following steps, resolve that problem before continuing.

Note 2: If reserve batteries are equipped, the volt meter on the DC power source should show approximately -48 V.

- 7 If not already done, connect each rectifier to its associated AC outlet and set the breakers in the power panel to ON.
- 8 Turn on the rectifiers, one at a time, waiting about 10 seconds between one rectifier and the next. Voltage at the distribution meter should go to about 54 V (equalize voltage) or 52 V (if equalize voltage has not been set up).

Note: Perform steps 9 through 12 for each column. Power on the Core columns last.

- 9 Replace the distribution fuses, or set the distribution breakers to ON, on the DC power source for the column.
- 10 Set the circuit breaker for the blower unit (the far left breaker in the rear of the pedestal) to ON in the column.
- 11 Set the switch on the blower unit (in the front of the pedestal) in the column to ON. You should hear the blower running.

Note: On initial power-up, the blower may rotate slower than expected. As the sensor detects heat, the blower will rotate faster.

- 12 Set the switch on the module power supply to ON in the column. After a few seconds, the green LED on the power supply should light.

Repeat this step for each module in the column, one module at a time. (If the module is equipped with a ringing generator, set the switch on both the power supply and the ringing generator to ON.)

Note: It may take up to 90 seconds for the green LED to light on a ringing generator. This is normal operation.

At this point, all blower units should be running and the green LEDs on all module power supplies and ringing generators should be lit. The red column LEDs will remain lit until the system reloads.

If you are currently upgrading your system, do not install new software, but return to your upgrade procedure in *Hardware Upgrade Procedures* (553-3001-258).

Performing acceptance tests

Content list

The following are the topics in this section:

Reference list	247
Acceptance tests	247
Module power supply test	248
Blower unit and thermal sensor test	249
Sysload test	252
System terminal and system monitor test	253
PFTU test	254

Reference list

The following are the references in this section:

- *Administration* (553-3001-311)
- *System Messages* (553-3001-411)

Acceptance tests

Perform the following acceptance tests after the system loading is completed:

- Module power supply test
- Blower unit and thermal sensor test
- Sysload test
- System terminal and system monitor test

- PFTU test (if PFTUs are equipped)
- Disk drive unit test

See *Administration* (553-3001-311) for a detailed explanation of software prompts and the *System Messages* (553-3001-411) for the meaning of system messages and display codes generated during acceptance tests.

Note: While performing the tests below, if you fail to see an expected display code, contact your Nortel Networks support representative for assistance.

Module power supply test

Use this procedure to test module power supplies and ringing generators and their interface to the system monitor. This procedure should be performed for each power supply at system installation, or whenever a module is installed.

Performing these tests on a single CPU system may cause a sysload.

Performing these tests on a dual CPU system may cause an initialization; disregard INI messages during the tests.

- 1 Verify that the green LED on each power supply is lit and that each red column LED is OFF.
- 2 Set the power supply to OFF. If there is an MPDU in the module, use the associated circuit breaker on the MPDU. If there is a switch on the power supply, use the switch.
 - The green LED on the power supply should go out.
 - The red column LED should light.
 - The system terminal should display PWR0002 and BSD090.

Note: If the power supply is in an IPE Module, XMI messages may be generated.

- The system terminal should then display BSD000.
- 3 Set the power supply to ON.
 - The green LED on the power supply should light.
 - The red column LED should go out.
 - The system terminal should display PWR0000.

- 4 Set the power supply to OFF. Wait until the red column LED lights, then unseat the power supply.
 - The red column LED should remain lit.
 - The system terminal should display PWR0002, BSD090, BSD000, and PWR0003.
- 5 Make sure the power supply switch is OFF and then push it back into the slot. Set the power supply to ON.
 - The green LED on the power supply should light.
 - The red column LED should go out.
 - The system terminal should display PWR0000.

Blower unit and thermal sensor test

Use this procedure to test the NT8D52 Blower Unit and its interface to the system monitor. This test should be performed on the blower unit when a column is initially installed.

Note: In the steps below, if you fail to see an expected display code, contact your Nortel Networks support representative.

- 1 In the front of the pedestal, set the blower unit circuit breaker, or power switch, to OFF.
 - The red LED at the top front of the column should light.
 - The system terminal should display PWR0006 and BSD090.

Note: Some DC powered blower units such as the NT8D52DD may also display PWR0005 and PWR0045.

- 2 Set the blower unit circuit breaker, or power switch, to ON.
 - The column LED should go out.
 - The system terminal should display PWR0046.
- 3 Use a screwdriver to loosen the retaining screws at the front of the blower unit (see Figure 102 on page 251) and pull the unit out until it is disconnected from the pedestal.

Note: Do *not* pull the unit all the way out of the pedestal.

 - The column LED should light.
 - The system terminal should display PWR0006 and BSD090.

- 4 Reinstall the blower unit and tighten the retaining screws.
 - The column LED should go out.
 - The system terminal should display PWR0046.
- 5 Heat one of the two thermal sensors under the top cap of the column with a hand-held hair dryer or similar heat source.
 - The column LED should light.
 - Thirty seconds after the thermal sensor detects 70 degrees C (158 degrees F), the main circuit breaker, or the blower unit circuit breaker, at the rear of the pedestal should trip. The system terminal should display PWR0004, PWR0006, and PWR0007.
- 6 Allow the sensor to cool, then reset the circuit breaker in the pedestal. If a sysload occurs, allow it to complete.
 - The column LED should go out.
 - The system terminal should display PWR0044, PWR0046, and PWR0047.
- 7 Repeat steps 5 and 6 for the other thermal sensor.

Figure 102
Blower unit removal

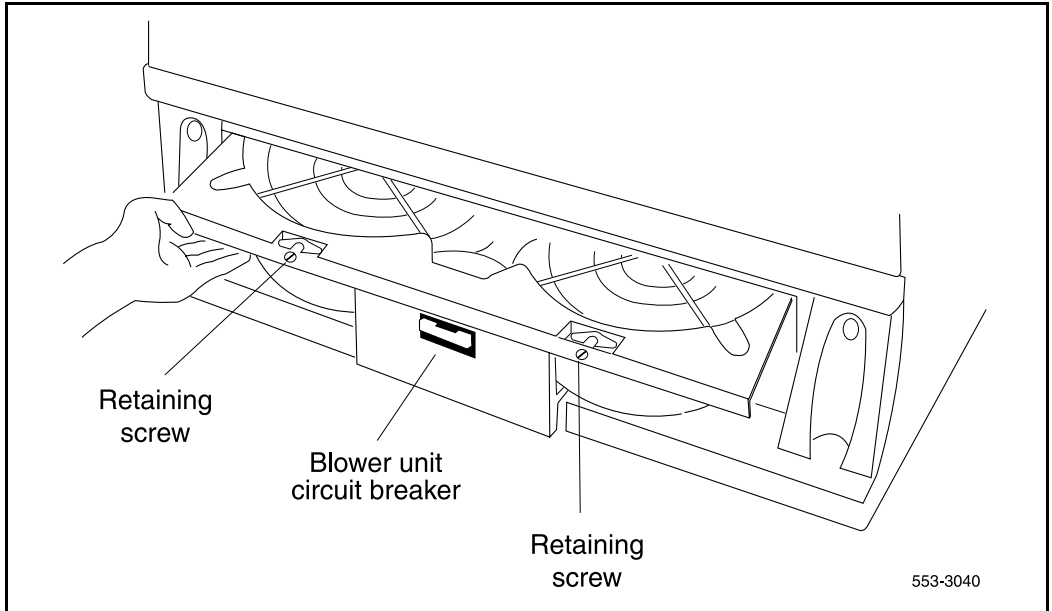

Sysload test

Use this procedure to test the sysload (manual reload) function.

- 1 Start the sysload:
 - **On Option 51C**, press the Man Rst button (the bottom button) on the Call Processor Card.
 - **On Options 61C, and 81C**, simultaneously press the MAN RST buttons (the bottom buttons) on both Call Processor Cards.
 - The following functions occur during a sysload:
 - **On all system options:**
 - The red LED at the top of the CPU column should light.
 - The major alarm indication should be displayed on all attendant consoles.
 - The LED on the front of the disk drive unit should light. (In Options 51C, 61C, and 81C, the LED on only one of the disk drive units will light.)
 - **On Options 51C, 61C, and 81C:**
 - The faceplate HEX displays on the IODVIC Card(s) should show a steady "A" with flashing decimal points when the card(s) complete a self-test.
 - On the LCD displays on the Card(s):
 - Following the "Selftest Complete" message, watch the LCD for the message "IOP in Slot 17."
 - Watch the LCD for the message "Loading Disk OS."
 - When the sysload is complete, the system terminal displays DONE and the system automatically invokes the initialization program.
 - The following functions occur when the initialization is complete:
 - The column LED should go out.
 - The major alarm indication should disappear from all attendant consoles.
 - The system automatically runs the programs in the midnight routine.
- 2 Press the return key on the system terminal to monitor the progress of the midnight routines until the OVL111 BKGD response is received.

System terminal and system monitor test

Use this procedure to test system terminals connected to the Meridian 1.

- 1 Log into the system:
LOGI (password)
- 2 Enter the program and check the status of the system monitor:
LD 37
STAT XSM
- 3 Test the terminal:
TTY x “x” is the device number assigned to the system terminal

The system terminal should display

```
ABCDEFGHIJKLM  
NOPQRSTUVWXYZ  
%*!&()<>=:,.?  
READY FOR INPUT
```

- 4 Step through the keys on the keyboard one at a time. All keyboard input should be echoed until END is entered.
- 5 Exit LD 37:

PFTU test

Use this procedure to test a PFTU and its interface with the system monitor.

- 1 Set the line transfer switch on the PFTU to BYPASS. Associated attendant consoles should display a major alarm.
- 2 Set the line transfer switch on the PFTU to NORMAL.
- 3 Set the line transfer switch on the attendant console associated with the PFTU to ON. Associated attendant consoles should display a major alarm.
- 4 Set the line transfer switch on the attendant console associated with the PFTU to OFF. The “major” alarm condition displayed on attendant consoles associated with the PFTU should disappear.
- 5 Repeat Steps 2 and 3 for each attendant console associated with the PFTU.
- 6 Set the line transfer switch on the PFTU to BYPASS and test the telephones and trunks connected to the PFTU.
 - Place an outgoing call from each telephone associated with the PFTU. Each telephone should be connected directly to a trunk.
 - Place an incoming call on each trunk associated with the PFTU. Each trunk should be connected directly to a telephone.
- 7 Set the line transfer switch on the PFTU to NORMAL and test the telephones and trunks connected to the PFTU. The telephones and trunks associated with the PFTU should return to normal operation.

Use this procedure to test the CMDUs in Options 51C, 61C, and 81C.

- 1 Log into the system:
LOGI (password)
- 2 Enter the program:
LD 137
- 3 Make sure the CMDU to be tested is not disabled:
STAT CMDU checks the status of both CMDUs
- 4 If the CMDU to be tested is disabled, enable it:
ENL CMDU x x represents the number for the specific CMDU

5 Test the CMDU:

TEST CMDU

If the system response is not “OK,” see the *X11 Administration* (553-3001-311) for the meaning of the message received.

6 Exit LD 137:

7 To test the second CMDU, enter

LD 135

Switch CPUs:

SCPU

Repeat steps 1 through 6.

Installing earthquake bracing

Content list

The following are the topics in this section:

Seismic-approved applications	257
Installing seismic bracing	258
Selecting the kit	258
Drilling the floor	261
Installing anchor plates	262
Installing rods	264
Positioning and leveling the system	266
Installing non-seismic bracing	271
Selecting the kit	271
Non-seismic anchor kit installation instructions	272

Seismic-approved applications

Depending on the geographic location, the Meridian 1 floor installation method may or may not require seismic bracing. To meet seismic bracing requirements, the installation must meet the Bellcore or the California OSHPD installation specifications. In locations that do not have earthquakes, a non-seismic installation is acceptable.

In certain seismic-approved applications where the pedestal attachment to the floor may be required but Nortel Networks does not offer the appropriate hardware, the installation organization must contact a seismic engineering firm to install the pedestal that meets Bellcore or California OSHPD requirements. This application could include attachment to a raised wood or steel floor.

The Meridian 1 system of universal equipment modules (UEM's) is designed to withstand most earthquakes. However, to ensure this earthquake security, the installation of two kits is required for each column—a bracing kit provides vertical support to each column of modules and an anchor kit secures each pedestal to the floor.

Installing seismic bracing

The Meridian 1 system has been certified to two of the most stringent seismic specifications for concrete floor mounting: BELLCORE and CALIFORNIA OSHPD:

- BELLCORE is intended for central-office equipment installations. The requirements are defined in the Network Equipment Building System (NEBS), General Equipment Requirements, TR-EOP-000063 issued by Bell Communications Research (BELLCORE). The Meridian 1 system has been certified to meet the maximum severity (Zone 4).
- CALIFORNIA OSHPD as part of the California building code, this specification requires the anchorage of all fixed hospital equipment to be approved by the California Office of Statewide Health Planning and Development (OSHPD), Division of Facilities Development and Financing. Meridian 1 has been certified for such installations under anchorage pre-approval number R-0233.

Selecting the kit

To select the applicable bracing and anchorage kits for your particular installation, you must first determine the following site requirements:

- Identify system configuration (number of columns and modules per column).
- Identify specification requirements (i.e., BELLCORE or CALIFORNIA OSHPD).
- Determine site mounting floor parameters (this information can usually be found in the engineering building drawings):
 - concrete type (hardrock vs lightweight aggregate),
 - minimum concrete compressive strength (megapascals or psi),
 - minimum concrete thickness

First, choose the appropriate module bracing kit using Table 47 on page 259. Select a separate kit for each column of modules. For column expansion (when an additional module is added to a column which already contains seismic bracing) the expansion bracing kit should be used

Table 47
Seismic Bracing Kits

Seismic Bracing Kit	System configuration
NT8D64CD	1-module
NT8D64CA	2-modules
NT8D64CB	3-modules
NT8D64CC	4-modules
NT8D64BD	expansion

Note: The NT8D64CD kit contains neither bracing rods nor tie bars because these are not needed for single module installations. The NT8D64BD kit does not contain mounting plates as these are not needed for column expansion.

Next, each column must also be secured to the floor. This is accomplished by installing one of two available anchor kits. Select the anchor kit by comparing the site requirements to Table 48 on page 260. This table shows that either anchor kit can be used to meet the CALIFORNIA OSHPD specification, but only Kit B meets the BELLCORE specification. For those installations where neither specification is required, Kit A is recommended due to its shallower concrete requirement.

Both anchor kits can be used in hardrock concrete as long as the compressive strength exceeds 20.7 megapascals (3000 psi). Only Kit A can be used in lightweight aggregate concrete with a compressive strength greater than 27.6 megapascals (4000 psi). The floor parameters for your installation can usually be found in the engineering building drawings.

Table 48
Seismic Anchor Kit

Kit	Seismic Anchor Kit	BELLCORE	CAL OSHPD	Concrete thk (min)	Light-weight
A	NT8D64BE	No	Yes	90 mm (3.54")	Yes
B	NT8D64CE	Yes	Yes	180 mm (7.09 ")	No

The kits listed in Table 48 on page 260 contain commercially available mounting hardware. You have the option of purchasing the contents directly from the manufacturer (using the listing below) or ordering the kits directly from Nortel Networks.

- Kit A (NT8D64BE) contains four of each of the following items:
 - Hilti HDI 3/4" (box of 25, manufacturer part# 457564), Hilti Corporation (918) 252-6000 or, Multi-Set II (manufacturer part# RM-34), ITW Ramset/Redhead, Incorporated (219) 874-4217
 - Hex head bolt, Ø.3/4"-10 x 1.50" long, steel material, zinc plate finish
 - Flat washer, internal diameter = 0.812", outside diameter = 1.469", thickness = 0.120", steel material, zinc plate finish
- Kit B (NT8D64CE) contains four of the following item:
 - Hilti HSL M16/25 (box of 10, manufacturers part# 665934), Hilti Corporation (918) 252-6000

Finally, to aid installation, four kits have been developed. The seismic anchor hole template kit (NT8D64BH) provides a mylar template to aid floor marking. Only one kit is needed for an installation and this kit is reusable.

Drilling the floor

The following tools are required to drill the holes for the anchor bolts:

- dark marking pencil
- center-punch
- rotary hammer drill
- carbide-tip drill bit:
 - 25.4 mm (1.00 inch) diameter (for Kit A, NT8D64BE)
 - 24.0 mm (0.94 inch) diameter (for Kit B, NT8D64CE)
- blowout bulb or compressed air source
- hammer or mallet
- vacuum



DANGER

Wear safety goggles when drilling anchor holes. For all drilling, use the appropriate tools and follow local codes. Make sure to obey all safety and warning precautions provided by the hammer drill and anchor bolt manufacturers.

Note: The following description applies only to installations into concrete floors.

- 1 Using the equipment room floor plan mark the position of all of the columns.
- 2 Center-punch each of the hole centers.

- 3 Using a carbide-tipped drill bit, hammer drill the holes to the size and depth shown in Table 49 on page 262.

Table 49
Anchor hole sizes

Kit	Kit part number	Hole diameter	Hole depth
A	NT8D64BE	1.00 inch	3.18 inch
B	NT8D64CE	24 mm	125 mm

Note: Special care should be taken in drilling the holes. The holes have to be drilled straight and perpendicular to the floor surface in order for the anchors to be installed correctly. The drill fixture kit can aid this process.

- 4 Should you hit reinforcing bar or the hole breaks through, abandon that hole and use the secondary hole location indicated in the anchor hole template.
- 5 Remove any debris from the holes with a blowout bulb or compressed air. Use a vacuum to dispose of the debris.
- 6 If the mounting plates are not to be installed immediately, cover the anchor holes to prevent debris from falling into them.

Installing anchor plates

The following tools are required to install the anchors and the anchor plates:

- Kit A
 - setting tool (Hilti HST 3/4", manufacturer part#329821)
 - 1 1/8 inch open-end wrench
- Kit B
 - 24 mm open-end wrench

Procedure for installing Kit A

- 1 Insert the anchors into the holes. Use the manufacturer's setting tool to install each anchor flush with the surface of the concrete. The setting tool is required for the Hilti anchor.
- 2 Locate the two mounting plates for each column over the anchors. Place an adapter bushing into each of the plate holes and insert a 3/4-inch diameter bolt and flat washer as shown in Figure 103 on page 263.

Figure 103
Mounting plate installation

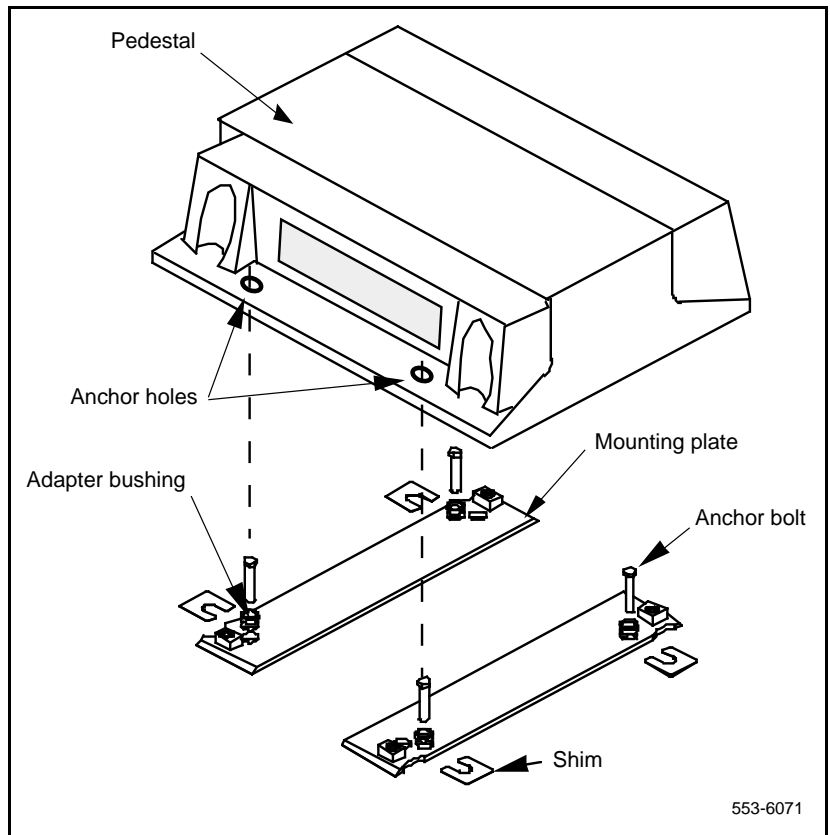

- 3 Level the plates with shims. Leave the stack of shims exposed until all leveling has been completed (this will allow the addition or removal of shims if necessary).
- 4 If the installation must meet CALIFORNIA OSHPD, tension proof load testing is required on 50 percent of the anchor bolts. These anchors must be tested to 24,020 newtons (5400 pounds) tension and 122 newton-meters (90 foot-pounds) torque. Any failure requires testing of all remaining anchors.
- 5 Go to "Installing rods" on page 264.

Procedure for installing Kit B

- 1 Locate the two mounting plates for each column over the anchor holes. Insert the anchors into the holes and tap the anchors into place with a mallet.
- 2 Level the plates with shims. Leave the stack of shims exposed until all leveling has been completed (this will allow the addition or removal of shims if necessary).
- 3 If the installation must meet CALIFORNIA OSHPD, tension proof load testing is required on 50 percent of the anchor bolts. These anchors must be tested to 6230 newtons (1400 pounds) tension and 122 newton-meters (90 foot-pounds) torque. Any failure requires testing of all remaining anchors.
- 4 Go to "Installing rods" on page 264.

Installing rods

The following tools are required to install the rods:

- 5/16 inch socket wrench
- 1/2 inch open-end wrench (for rods)

- 9/16 inch open-end wrench (for nuts)
- Note:** The rods should be installed before you position the columns.
- 1 Remove the top cap on each column:
 - Pull forward on the clips underneath the front edge of each air exhaust grill on the top cap. Lift up and remove the grill as illustrated in Figure 104 on page 265.

Figure 104
Exhaust grill removal

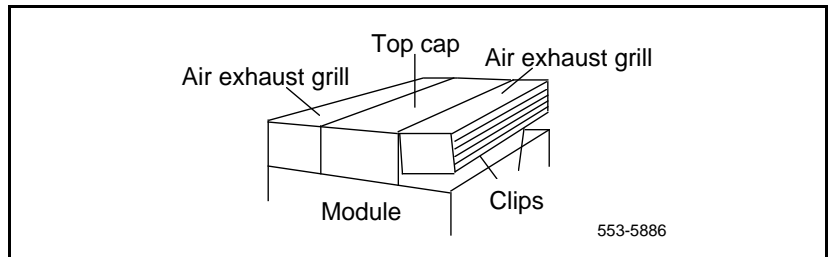

- Use a 5/16 in. socket wrench to remove the six screws that secure the top cap (see Figure 105 on page 267). Lift the top cap from the column.
- 2 Remove the side panels on the exterior of each module by removing the four bolts that secure the panel.

Note: In a two-tier or three-tier column, with adequate ceiling clearance, you may be able to thread the rods down the sides of the column without removing the side panels. Insert each rod into its hole at the top of the column.

- 3 Install bracing rods:
 - Position each rod in one of the vertical slots along the sides of the modules and insert the rods into the threaded holes in the pedestal (see Figure 106 on page 268). Tighten the rods in by hand or snug tight with a 1/2" open-end wrench.
 - Place a tie bar over each pair of rods, from side to side across the top of the module, as shown in Figure 106 on page 268.
 - Secure the tie bars with flat washers and hexagon nuts. Torque with 9/16" wrench to 17.6 joules (13.0 ft-lbs).

Note: When installing expansion rods as part of the NT8D64BD bracing kit, the rods are screwed into the previously-installed rods by means of a coupling nut. The resulting two-piece rod should be secured in the same manner as the single rod described above.
- 4 Reinstall the top cap and grills:
 - Position each top cap and install the bolts that secure it.
 - Replace the air exhaust grills at the front and rear of each top cap.
- 5 **For a single-column system**, reinstall the side panels on each module.
- 6 **For a multiple-column system**, install NT8D49AA Spacer Kits between adjacent columns:
 - Attach gaskets to both sides in the front section of each spacer (see Figure 107 on page 269).
 - Attach a spacer to one side of each module that will be next to another module, except on the end column (see Figure 107 on page 269 and Figure 108 on page 270). Insert the screws through holes in the trim panels.
- 7 Go to "Positioning and leveling the system" on page 266.

Positioning and leveling the system

The following tools are required to position and level the system:

- socket wrench (anchor bolts):

Figure 105
Top cap assembly

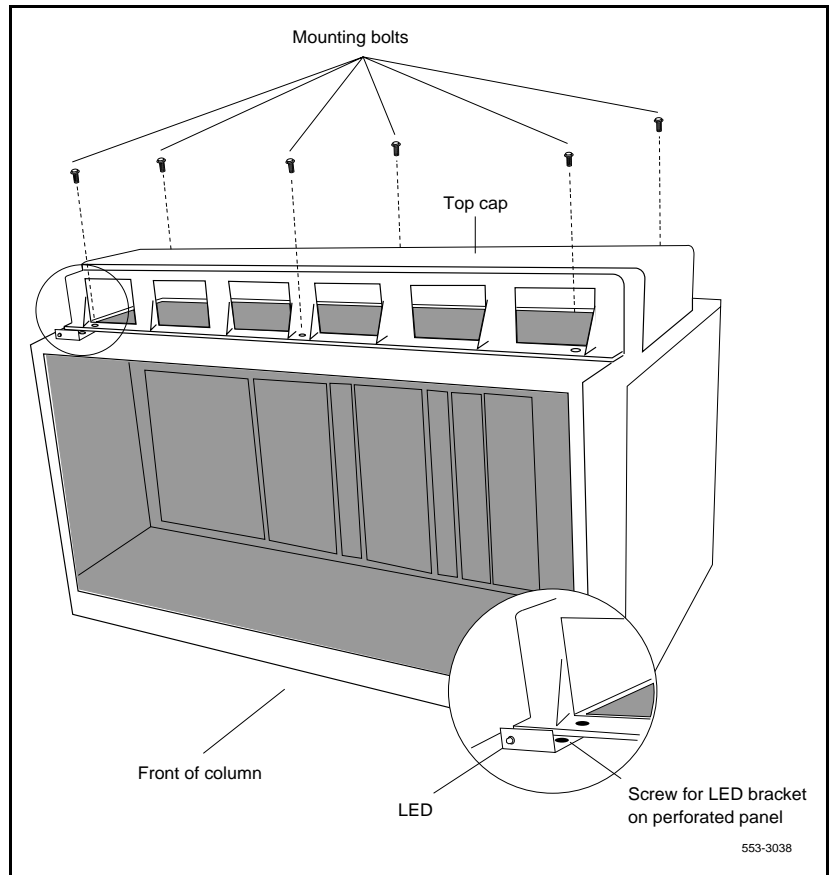

— 1 1/8 inch for Kit A

— 24 mm for Kit B

- 5/8" socket wrench (pedestal bolts)

Follow the steps below to level the system:

- 1 Loosen the anchor bolts until the mounting plates are free to move.
- 2 Starting from one end of the line-up, move a column into position.

Figure 106
Installing bracing rods for column support

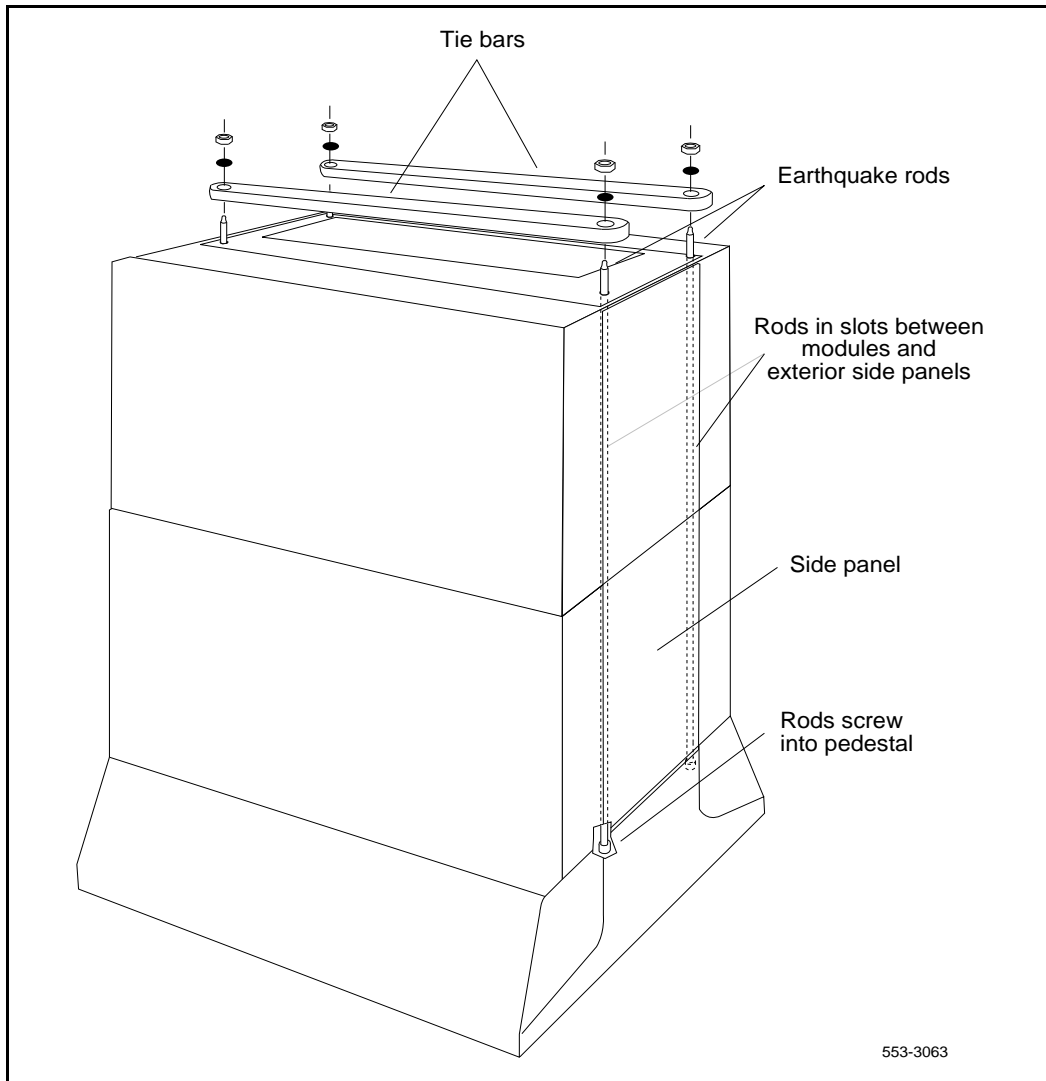

- 3** Loosely install the pedestal mounting hardware (1/2" bolts, lockwasher, plain washer, and insulating washer), using the plastic insulating washers.

- 4 Re-level the column, adding or removing shims as needed. Go back and re-level any other columns.
- 5 Repeat the above steps until all columns have been positioned.
- 6 Slide shims completely under seismic plates. First tighten the pedestal mounting bolts, torque to 122 Newton-meters (90 ft-lbs). Then, tighten the concrete anchors, torque to 48 Newton-meters (35 ft-lbs).

Figure 107
Positioning spacer gaskets

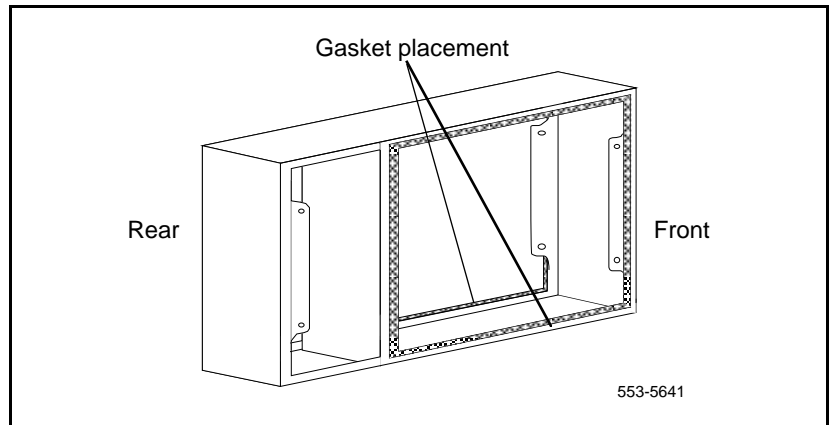
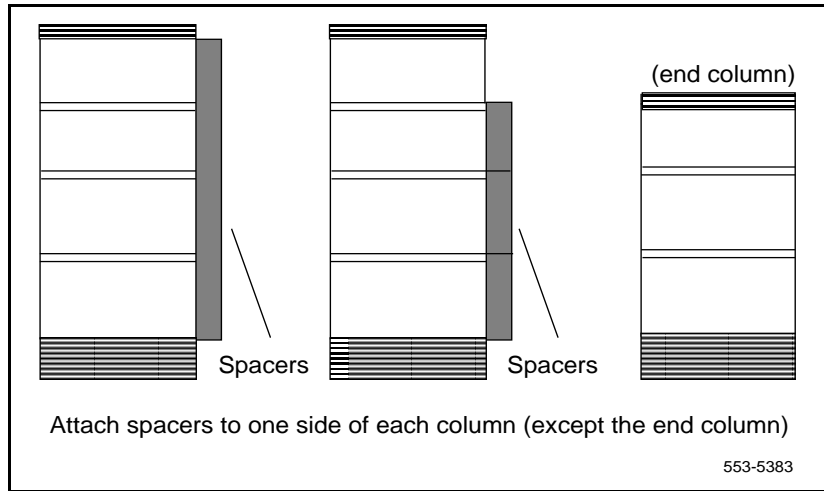

Figure 108
Adding spacers to columns



Installing non-seismic bracing

In certain applications where earthquakes do not occur, the pedestal attachment to the floor does not have to meet Bellcore or California OSHPD requirements. This application could include attachment to a raised wood or steel floor using the kits described below.

Selecting the kit

If the installation does not have to meet the Bellcore or OSHPD requirements, the installer can design and install an attachment suitable for the particular installation using:

- NT8D64BF Floor Mounting Kit
- NT8D6401 Insulating Washer Kit

NT8D64BF Floor Mounting Kit

The NT8D64BF Floor Mounting Kit provides the hardware required to secure a Meridian 1 column to concrete floors for non-seismic installations i.e., for a non-Bellcore or OSHPD approved installation.

The kit provides four sets of hardware however, a minimum of two anchors must be used diagonally opposite to secure the column pedestal to the floor. The kit also provides four insulating washers that can be used during kit installation.

NT8D6401 Insulating Washer Kit

The NT8D6401 Insulating Washer Kit is used for attaching the Meridian 1 to the floor when the installer is using a third party anchor kit instead of the Nortel Networks NT8D64BF Floor Mounting Kit.

In this case, one NT8D6401 Insulating Washer Kit is required for each pedestal to electrically insulate the mounting bolts from the pedestal casting. Each NT8D6401 Insulating Washer Kit provides four insulating washers.

Non-seismic anchor kit installation instructions

To install the NT8D64BF Floor Mounting Kit:

- 1 Mark the position of each Meridian 1 column using the equipment room floor plan.
- 2 Mark the location of all four anchor holes for each column using a dark marking pencil.
- 3 Center-punch the center of each hole in the concrete.
- 4 Make the hole in concrete by using a rotary hammer drill to the following size and depth:
 - hole diameter 0.625"
 - hole depth 2.00"
- 5 Abandon the hole if you should hit a reinforcing bar or the hole breaks through. A minimum of two diagonally opposite anchors are required for this application.
- 6 Remove any debris from the hole with a blowout bulb or compressed air. Use a vacuum cleaner to dispose of the debris.
- 7 Insert the anchors into the holes. Use the manufacturer's setting tool to install each anchor flush with the surface of the concrete. Use the Hilti HST 1/2" setting tool, manufacturer part # 000329805 or equivalent.
- 8 Position each column over the anchors.
- 9 Insert bolt, metal washer, and shoulder washer into the pedestal hole, as shown in the Figure 109 on page 273. On the far side of the pedestal flange, thread a plastic washer, a metal washer, and the nut onto the bolt.
- 10 Insert the bolt into the concrete anchor.
- 11 Tighten the nut to the pedestal flange and torque it to the 34 Newton-meters (25 ft-lbs) using a 3/4" socket wrench. Do not overtighten.
- 12 Repeat steps 8 to 11 for remaining bolts.

Figure 109
Pedestal mounting flange (rear view)

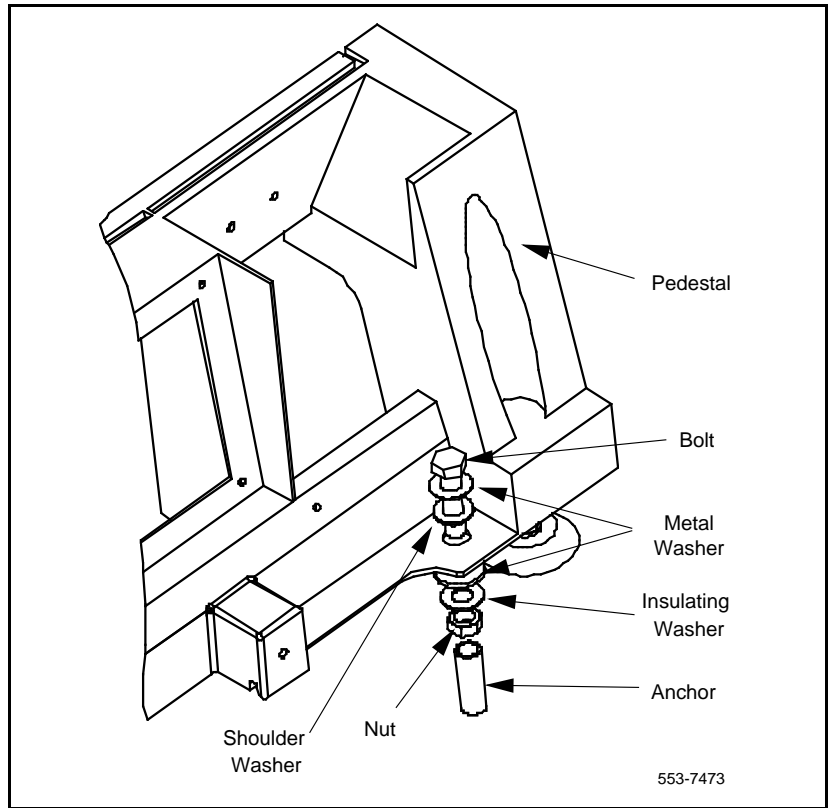

Adding a module to a column

Content list

The following are the topics in this section:

Adding modules	275
Adding a module to the base of a column	276
Adding a module between two other modules	279
Adding a module to the top of a column	285

Adding modules

The procedures in this chapter apply to adding a module to a column that is fully equipped and powered up. To add a fourth module to a column during initial system installation, see the procedure for placing the fourth module on a column in “Initial Meridian 1 installation” on page 15.



CAUTION

Damage to Equipment

A module containing the system CPU (common equipment cards) should never be installed at the third or the fourth tier of a column. Modules containing common equipment should always be installed in the bottom two tiers of Meridian 1 columns. This ensures optimum cooling for the common equipment cards.

A module can be added to a column in one of three positions; a procedure is given for each:

- “Adding a module to the base of a column” on page 276

- “Adding a module between two other modules” on page 279
- “Adding a module to the top of a column” on page 285

If the column is equipped with earthquake bracing, the column support rods must be removed and longer rods must be installed after the module is added. To change the rods, see “Installing earthquake bracing” on page 257.



WARNING

A fully loaded module weighs approximately 58.9 kg (130 lbs). More than one person is required to move a module.



DANGER OF ELECTRIC SHOCK

In a DC-powered system, power to the column can remain on during the following procedures. In an AC-powered system, however, power to the entire column *must* be shut down throughout the procedures.

Adding a module to the base of a column

If conduit or other cabling runs through modules that are being moved, you must tag and disconnect the cables, pull them out of the modules, and reroute them after all of the modules are repositioned. The top cap can remain on the module it is attached to.

- 1 Disconnect and remove the NT8D22 System Monitor for the column in the rear of the pedestal (do *not* turn off the blower unit in the front of the pedestals):
 - If the column houses the master system monitor, load overlay 37 and software disable the associated SDI port:

LD 37
DIS TTY x disable the device associated with the port
 - Disconnect the RJ11 cable to J3, then the cable to J6, then pull the system monitor out of the slot.
- 2 Set all circuit breakers in the rear of the pedestal to OFF (down).

- 3 Remove the module above the pedestal:
 - Disconnect the power connector to the pedestal (see Figure 110 on page 277).

Figure 110
NT7D09CA Pedestal—module power and system monitor connections

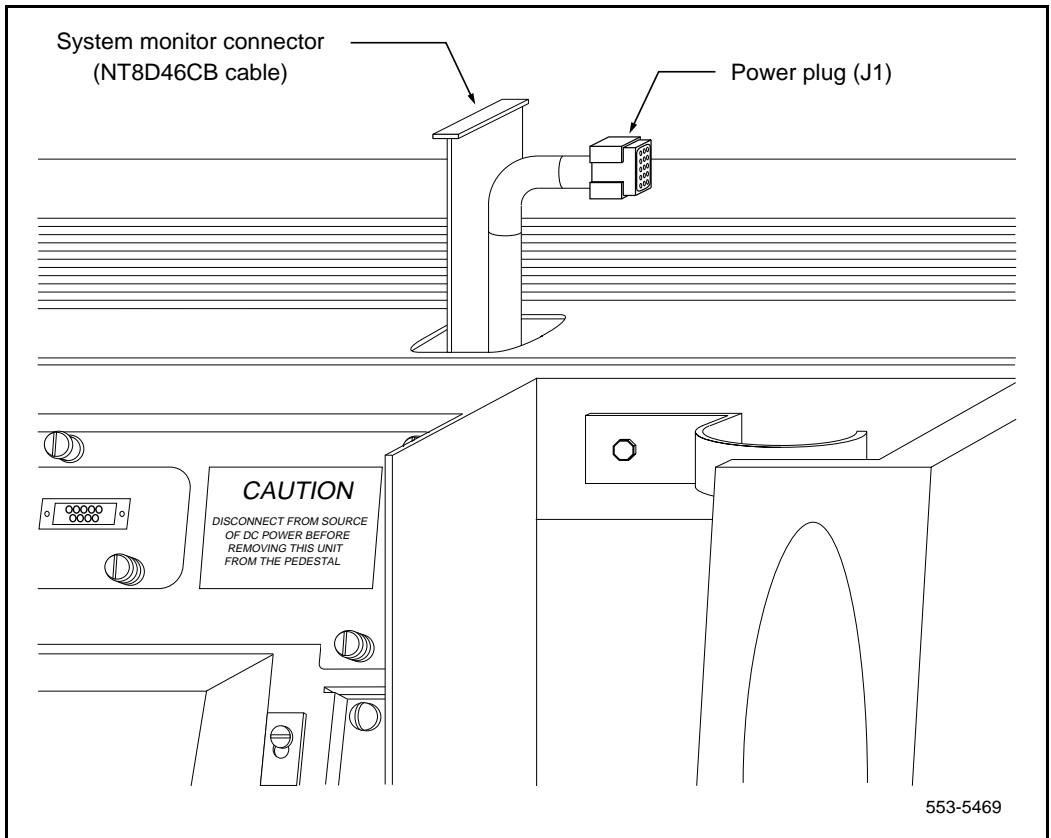

Note: You must press a latch trip on the front and rear of the plug. You may need to use a screwdriver blade against the latch trip on the front of the plug.

- Disconnect the system monitor connector to the pedestal (see Figure 110 on page 277).
- Use a 9/16 in. socket wrench to remove the five mounting bolts that

secure the module (see Figure 111 on page 278) and lift it off the column.

Figure 111
Module mounting bolts

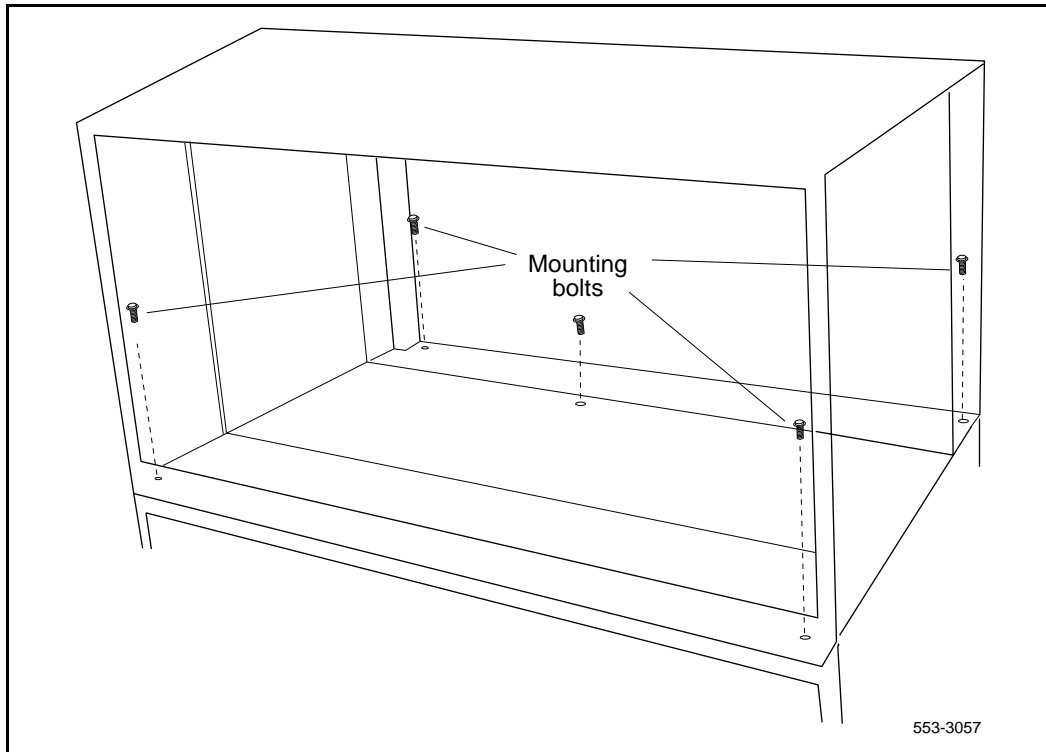

Note: There is an EMI shield (it looks like a brass grill) on the top of each pedestal. Leave this shield on the pedestal. Use a few pieces of tape to hold the shield in position, so the holes for the mounting bolts are aligned with the screw holes on the pedestal. After the module is secured, remove as much of the tape as possible.

- 4 Position and secure modules:
 - Locate the positioning guides on the pedestal. Make sure the module being added is facing the same direction as the column.
 - Place the module being added on the pedestal and adjust it until it is seated securely on the positioning guides.
 - Secure the mounting bolts for the module.
 - Place the module that was removed onto the top of the module that was added and secure it with the mounting bolts.
- 5 Connect the power and system monitor cables in the module:
 - Connect the power connectors to the pedestal and to the module above (see Figure 110 on page 277 and Figure 112 on page 280).
 - Attach the frame ground wires to the frame ground post at the base of the module.
 - Connect the system monitor cable from the pedestal to connector J1 on the module being added.
 - Connect the system monitor cable from connector J2 in the module being added to J1 in the module above.
- 6 Set all circuit breakers in the pedestal to ON.
- 7 Reinstall the system monitor in the pedestal:
 - Reconnect the RJ11 cable to J6, then the cable to J3. Reinstall the system monitor.
 - If the column houses the master system monitor, load overlay 37 and software reenables the associated SDI port:

LD 37

```
ENL TTY x          enable the device associated with the port
****              exit LD 37
```

- 8 Replace all module covers and the pedestal grill.

Adding a module between two other modules

If conduit or other cabling runs through modules that are being moved, you must tag and disconnect the cables, pull them out of the modules, and reroute them after all of the modules are repositioned.

Figure 112
Module-to-module power and system monitor connections

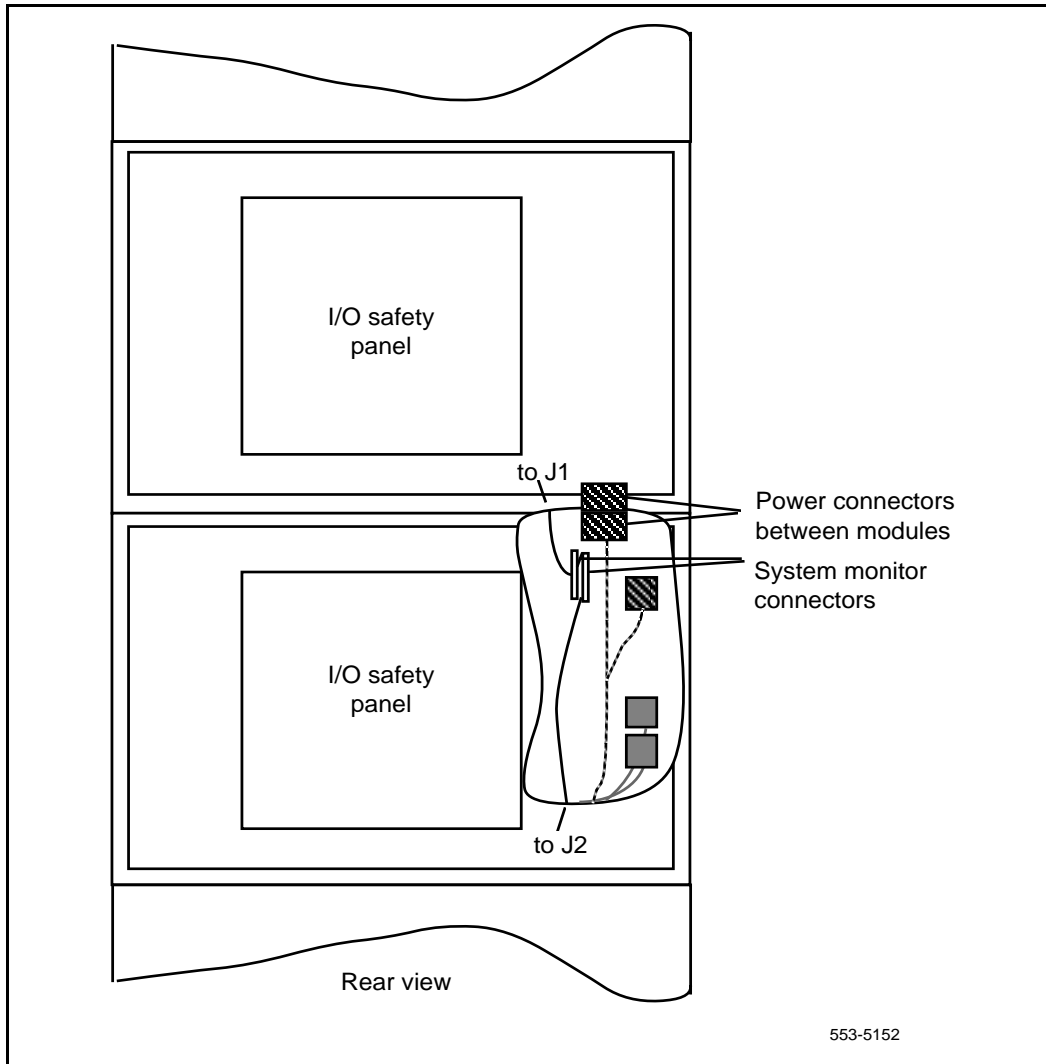

The top cap can remain on the module it is attached to.

- 1 Disconnect and remove the NT8D22 System Monitor for the column in the rear of the pedestal (do *not* turn off the blower unit in the front of the pedestals):

- If the column houses the master system monitor, load overlay 37 and software disable the associated SDI port:

LD 37

DIS TTY x disable the device associated with the port

- Disconnect the RJ11 cable to J3, then the cable to J6, then pull the system monitor out of the slot.

- 2 Turn off power as necessary:

- With AC power, set the main circuit breaker for the column to OFF (down) in the rear of the pedestal.



DANGER OF ELECTRIC SHOCK

Due to hazardous voltage in AC-powered systems, power to the entire column must be shut down. This shuts down all functions in the column.

- With DC power, set the switch on the module power supply and the circuit breaker in the rear of the pedestal to OFF (down) for any module that will be moved and for the module being added. (All other modules in the column can safely retain power.)
- 3 Remove the module that will be above the module being added:
 - Disconnect the power connectors between the modules (review Figure 112 on page 280).
 - Disconnect the system monitor cable from connector J1 in the module that will be above the module being added.
 - Use a 9/16 in. socket wrench to remove the five mounting bolts that secure the module and lift it off the column (see Figure 113 on page 283).

- 4** Position and secure modules:
 - Locate the positioning guides on what is now the top module in the column (see Figure 114 on page 284). Make sure the module being added is facing the same direction as the column.
 - Place the module being added on top of the column and adjust it until it is seated securely on the positioning guides.
 - Secure the mounting bolts for the module.
 - Place the module that was removed on top of the module that was added and secure it with the mounting bolts.

- 5** Connect the power and system monitor cables between modules:
 - Connect the power connectors between the module being added and the modules above and below it.
 - Connect the system monitor cable from connector J2 in the module below to J1 in the module being added (review Figure 112 on page 280).

Connect the system monitor cable from J2 in the module being added to J1 in the module above.

- 6** Restore power to the module:
 - With AC power, set the main circuit breaker to ON (up) in the rear of the pedestal.
 - With DC power, set the circuit breaker in the rear of the pedestal then the module power supply to ON (up) for the module that was added and for any module that was moved.

Figure 113
Module mounting bolt

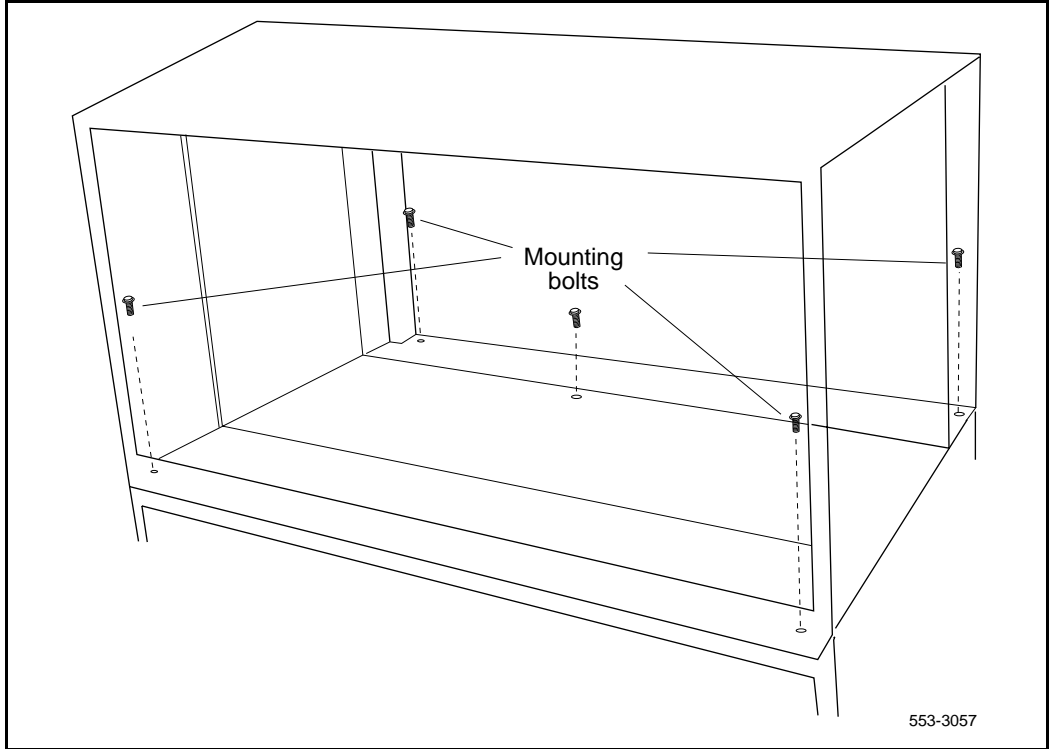
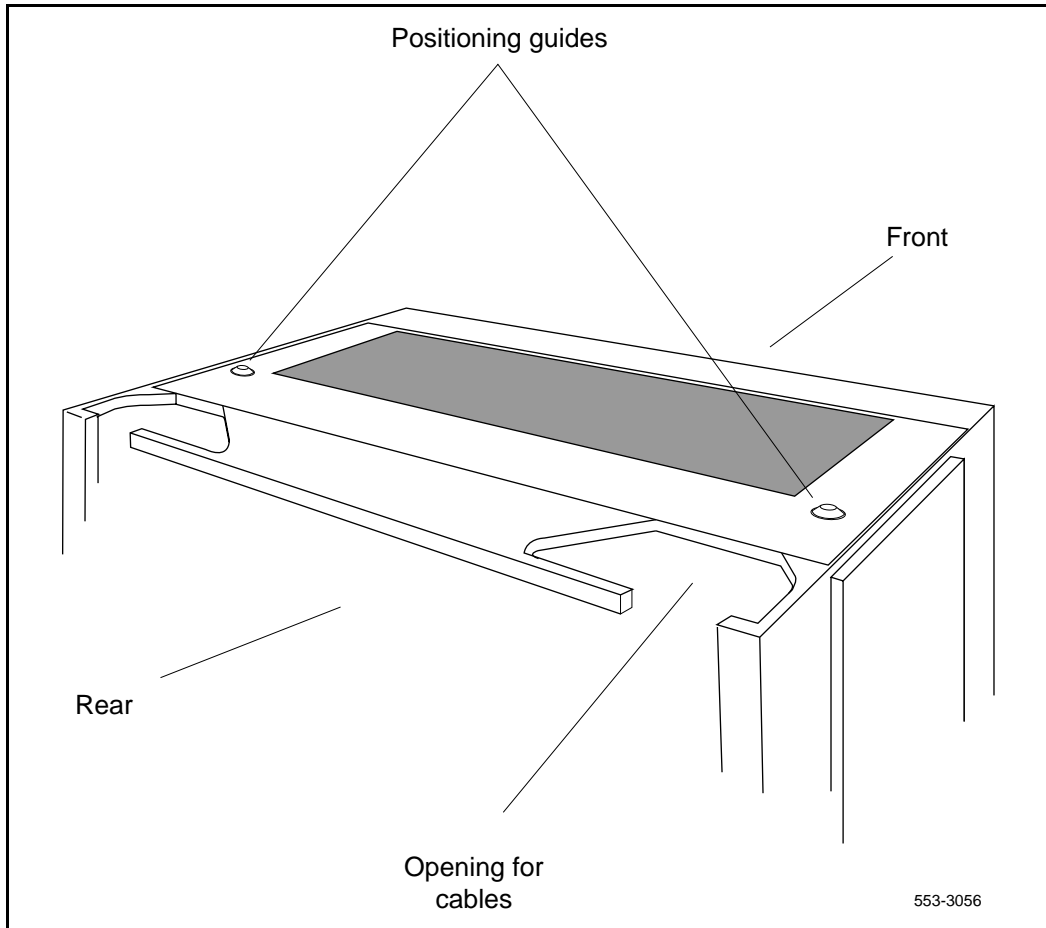

Figure 114
Module positioning guides



- 7 Reinstall the system monitor in the pedestal:
 - Reconnect the RJ11 cable to J6, then the cable to J3. Reinstall the system monitor.
 - If the column houses the master system monitor, load overlay 37 and software reenables the associated SDI port:

LD 37

ENL TTY x enable the device associated with the port

 exit LD 37

- 8 Replace all module covers and the pedestal grill.

Adding a module to the top of a column

In a DC-powered system, power to the column can remain on during this procedure.

If conduit or other cabling runs through the top cap, you must tag and disconnect the cables, pull them out of the way, and reroute them after the new module and the top cap are positioned.

- 1 Disconnect and remove the NT8D22 System Monitor for the column in the rear of the pedestal (do *not* turn off the blower unit in the front of the pedestals):
 - If the column houses the master system monitor, load overlay 37 and software disables the associated SDI port:

LD 37

DIS TTY x disable the device associated with the port

- Disconnect the RJ11 cable to J3, then the cable to J6, then pull the system monitor out of the slot.

- 2 Turn off power as necessary:
 - With AC power, set the main circuit breaker for the column to OFF (down) in the rear of the pedestal.



DANGER OF ELECTRIC SHOCK
Due to hazardous voltage in AC-powered systems, power to the entire column must be shut down. This shuts down all functions in the column.

- With DC power, set the switch on the module power supply and the circuit breaker in the rear of the pedestal to OFF (down) for the module being added.
- 3 Disconnect power connections to the top cap:
 - At the top of the rear of the module, disconnect the orange power connector from the module power harness (see Figure 115 on page 286). Press the four tabs (two on each side) and let the connector fall loose into the module below.

Figure 115
Orange power connector removal tab locations

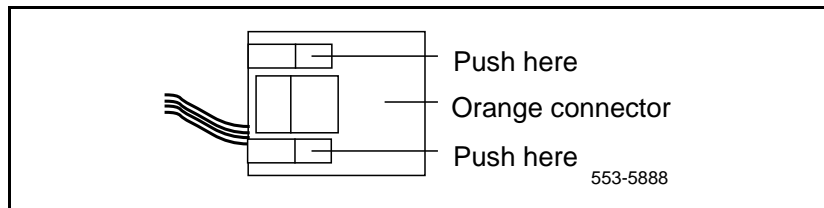

- Disconnect the system monitor cable at connector J2 on the backplane.

- 4 Remove the top cap and perforated panel:
- For countries other than the UK, pull forward on the clips underneath the front edge of each air exhaust grill on the top cap. Lift up and remove the grill as illustrated in Figure 116 on page 287).

Figure 116
Air exhaust grill removal

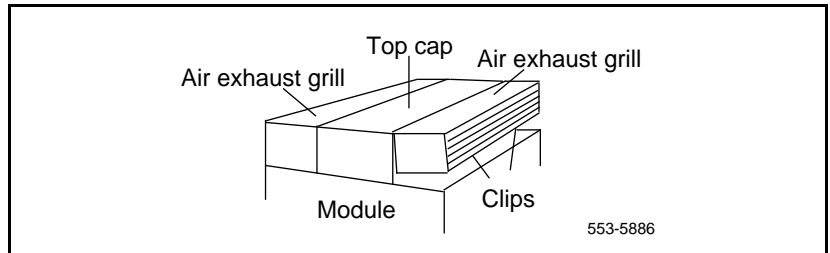

- In the UK, the front and rear air exhaust grills are secured by Southco fasteners located underneath the front edge of the grill. Use a #1 Phillips head screwdriver and turn the fasteners 1/4-turn to release or secure the grill.

Figure 117
UK air exhaust grill removal

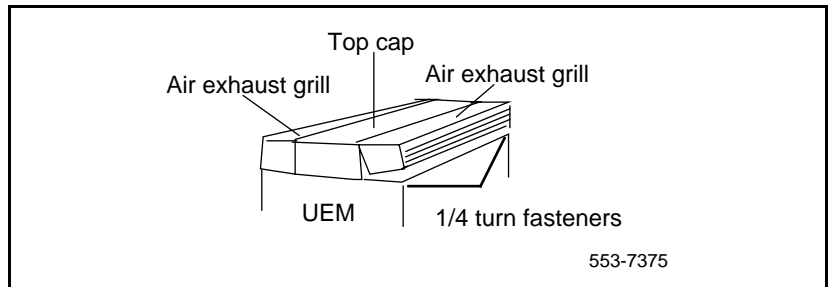

- Use a 5/16 in. socket wrench to remove the six bolts that secure the top cap (see Figure 118 on page 288). Remove the top cap from the column.
- Remove the screw that secures the perforated panel and LED bracket. Slide the panel slightly to the left (looking at it from the rear of the column) and remove it.

Figure 118
Top cap assembly

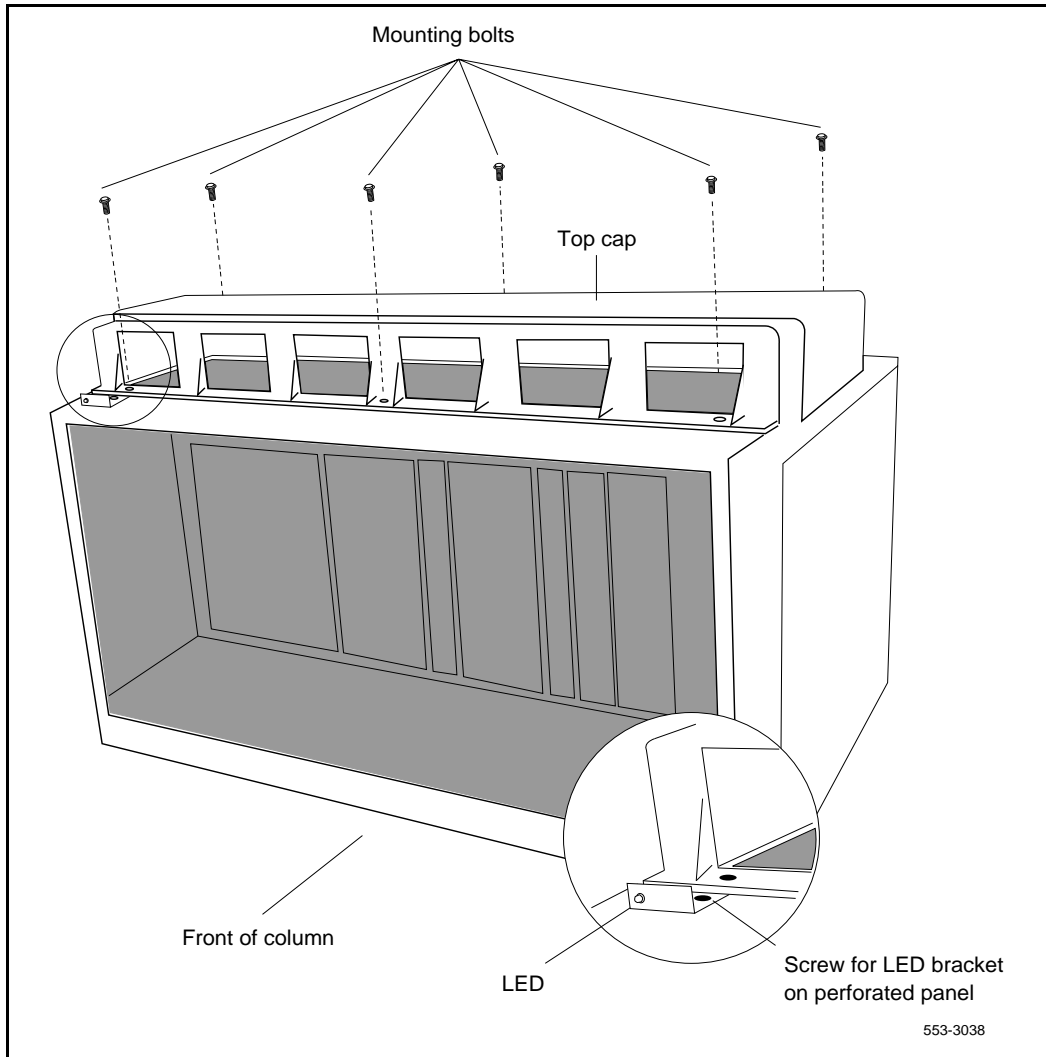

- 5 Position and secure the module being added:
 - Locate the positioning guides on the module in the column (see Figure 119 on page 289). Make sure the module being added is facing the same direction as the column.

Figure 119
Module positioning guides

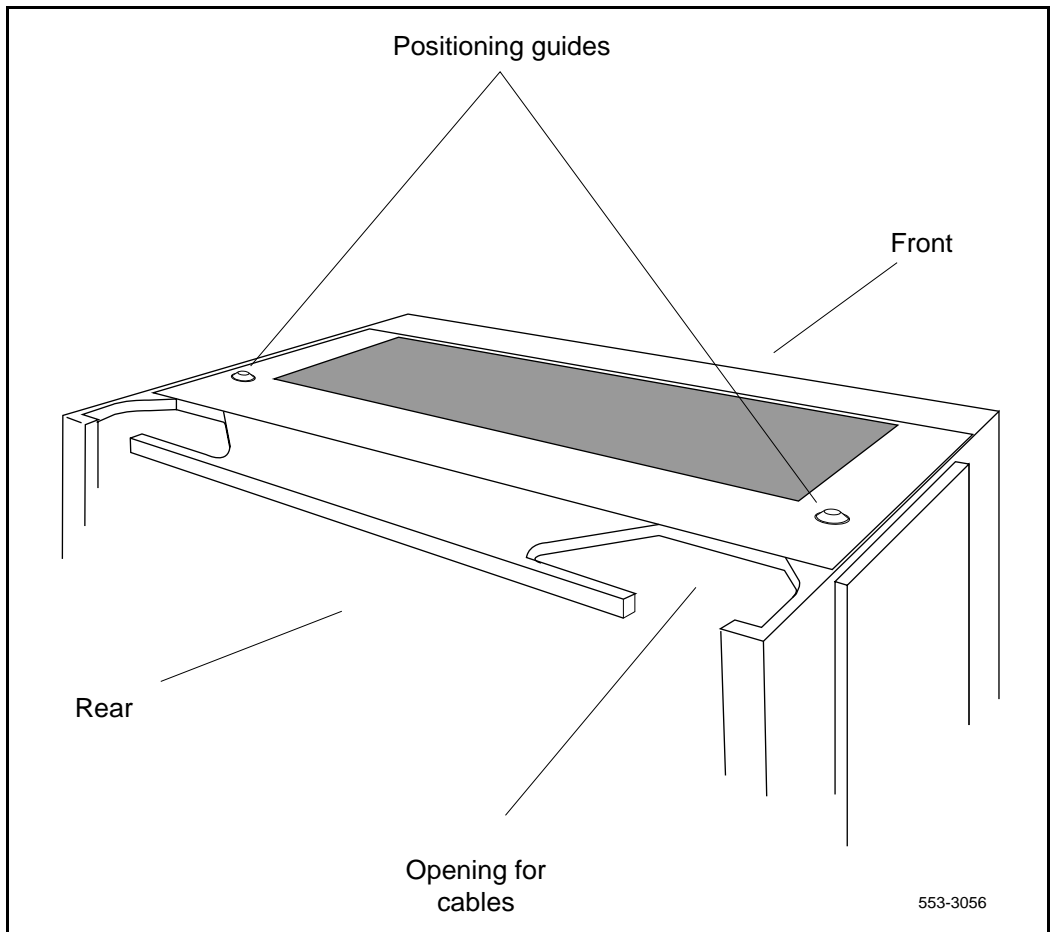

- Place the module being added on top of the column and adjust it until it is seated securely on the positioning guides.
- Use a 9/16 in. socket wrench to secure the module with five

mounting bolts (see Figure 120 on page 290).

Figure 120
Module mounting bolts

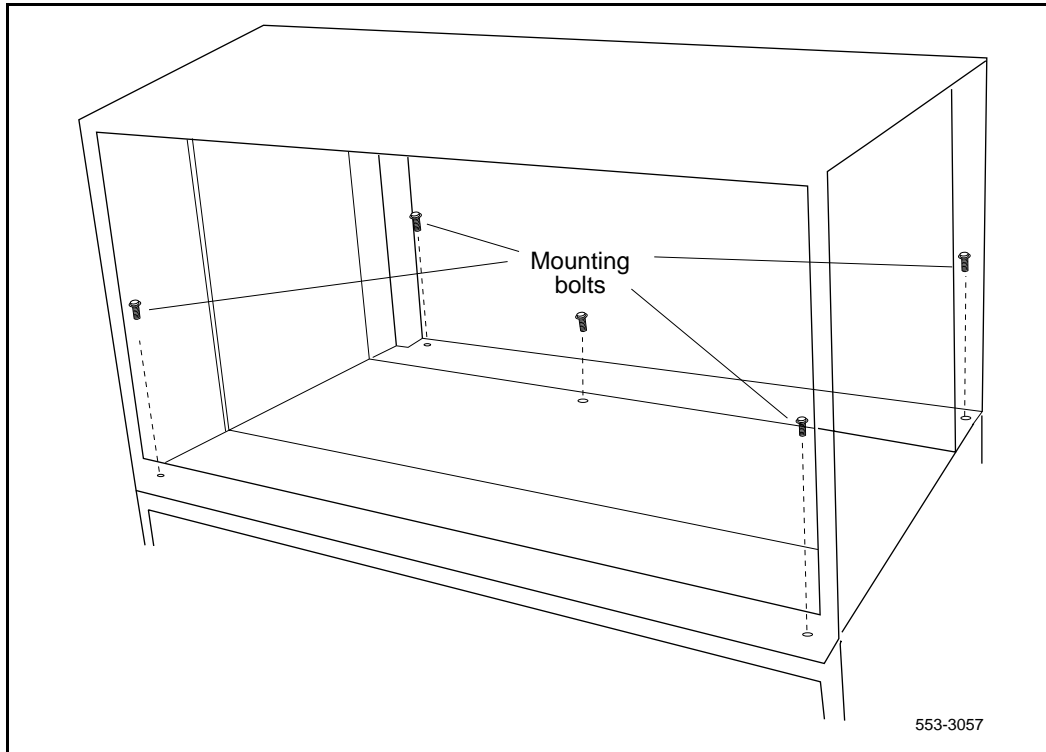

- 6** Connect the power and system monitor cables between modules:
 - Connect the power connectors between the module being added and the module below it (see Figure 121 on page 291).
 - Connect the system monitor cable from connector J2 in the lower module to J1 in the module being added (see Figure 121 on page 291).

Figure 121
Module-to-module power and system monitor connections

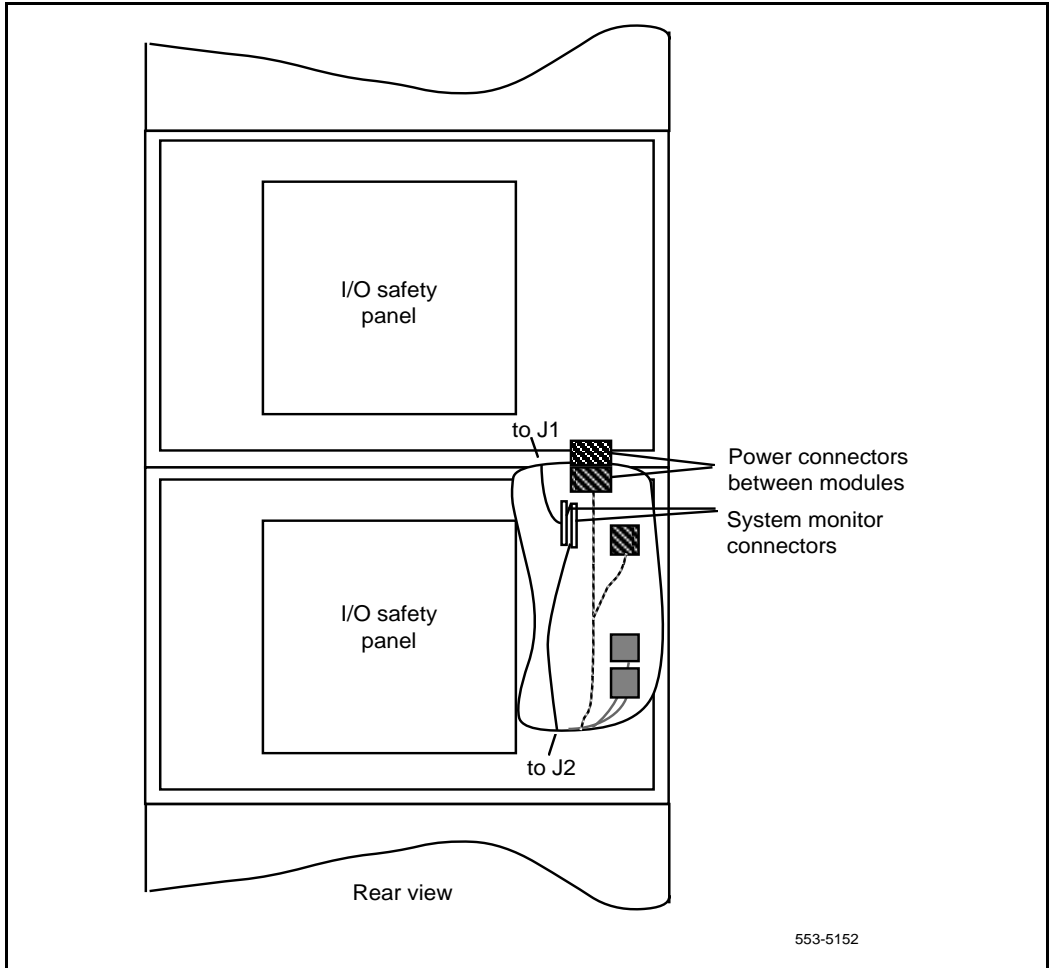

- 7 Install the perforated panel and top cap on the module being added:
 - Position the perforated panel and slide it slightly to the right (at the rear). Install the screw that secures the panel and LED bracket.
 - Position wiring from the perforated panel so it rests in the cable well located next to the orange power connector at the rear of the module (see Figure 122 on page 292).

Figure 122
Cable well location

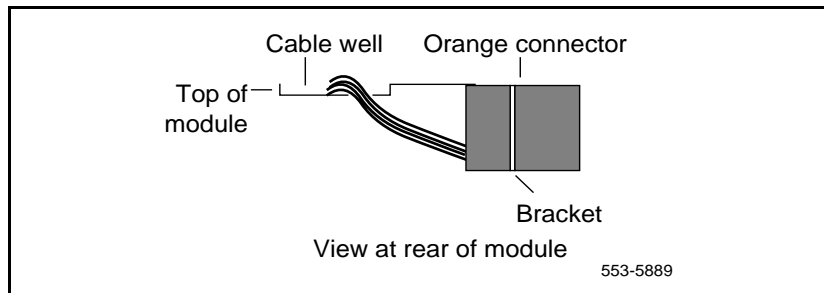

- Position the top cap and install the bolts that secure it.
 - Replace the air exhaust grills at the front and rear of the top cap.
- 8 Reconnect power to the top cap:
 - Connect the system monitor cable to J2 on the backplane. Line up the alignment tab on the connector and snap on the pin headers to position the connector correctly (see Figure 123 on page 292).

Figure 123
Monitor cable J2 backplane alignment tab and key alignment

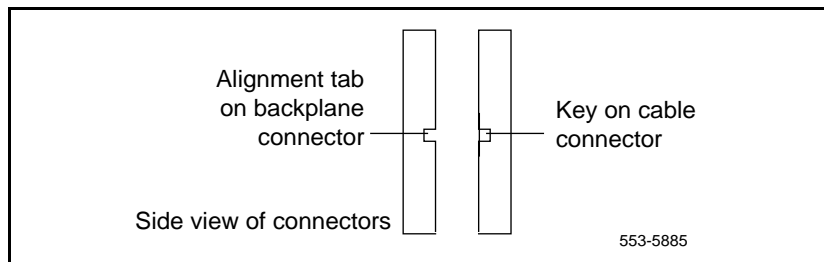

- 9** Connect the orange power connector to the module power harness. Restore power to the module:
- With AC power, set the main circuit breaker to ON (up) in the rear of the pedestal.
 - With DC power, set the circuit breaker in the rear of the pedestal and then set the module power supply to ON (up) for the module that was added.
- 10** Reinstall the system monitor in the pedestal:
- Reconnect the RJ11 cable to J6, then the cable to J3. Reinstall the system monitor.
 - If the column houses the master system monitor, load overlay 37 and software re-enable the associated SDI port:

LD 37

ENL TTY x enable the device associated with the port
**** exit LD 37

- 11** Replace all module covers and the pedestal grill.

Appendix A: NT0R72, NT6D82, QBL12, QBL15, QCA13

Content list

The following are the topics in this section:

Reference list	295
AC-input receptacle	295
Installing an NT6D82 Power System	296
Installing a QBL12 distribution box	296
Installing a QBL15 power system	301
Installing a QCA13 power plant	316
Installing safety ground/protective earth and logic return wiring	316
Connecting the PDU	323
Connecting the NT8D22 system monitor	334

Reference list

The following are the references in this section:

- *Installation Planning* (553-3001-120)
- *Power Engineering* (553-3001-152)

AC-input receptacle

DC-powered systems generally require one AC-input receptacle per rectifier within 1.8 m (6 ft) of each rectifier. The input receptacles required are determined by the number and type of rectifiers used.

Note: A junction box may be used with the NT7D67CB PDU, but it is not required.

For information on customer-supplied power equipment, refer to Appendix C: “Customer supplied power equipment” on page 361.

Installing an NT6D82 Power System

The NT6D82 Power System can be used with all system options, but it is optimized for larger Option 61C configurations).

The NT6D82 Power System is an enclosed, front-access power distribution and control panel that supports from one to three 100-amp rectifiers per rack. One to three racks can be paralleled in a single configuration. The maximum capacity of three fully equipped racks is 900 amps.

The rectifiers in an NT6D82 operate on single-phase, 60 Hz, AC service and can be strapped for either 120, 208, or 240 V nominal input. The NT6D82 Power System requires one 50-amp power feed per rectifier.

To install an NT6D82 Power System, follow the instructions provided with the NT6D82 equipment.

Installing a QBL12 distribution box

The QBL12 Power Distribution Box is a wall-mounted unit that connects a customer-provided power plant to Options 81 (and larger Option 61C configurations) (see Figure 124 on page 297).

The QBL12 distribution box connects up to 12 Meridian 1 columns (48 modules), with a maximum allowable load current of 600 amps. The distribution box contains 24 distribution fuses. Each distribution fuse supports two modules. Generally, one QBL12 is required per system.

For the receptacle requirements for the customer-provided power plant, refer to the manufacturer’s specifications.

Installing a QBL12 and connecting to the power plant or batteries

If batteries are used, follow directions from the power plant manufacturer to connect the batteries to the power plant.

Figure 124
QBL12 distribution box

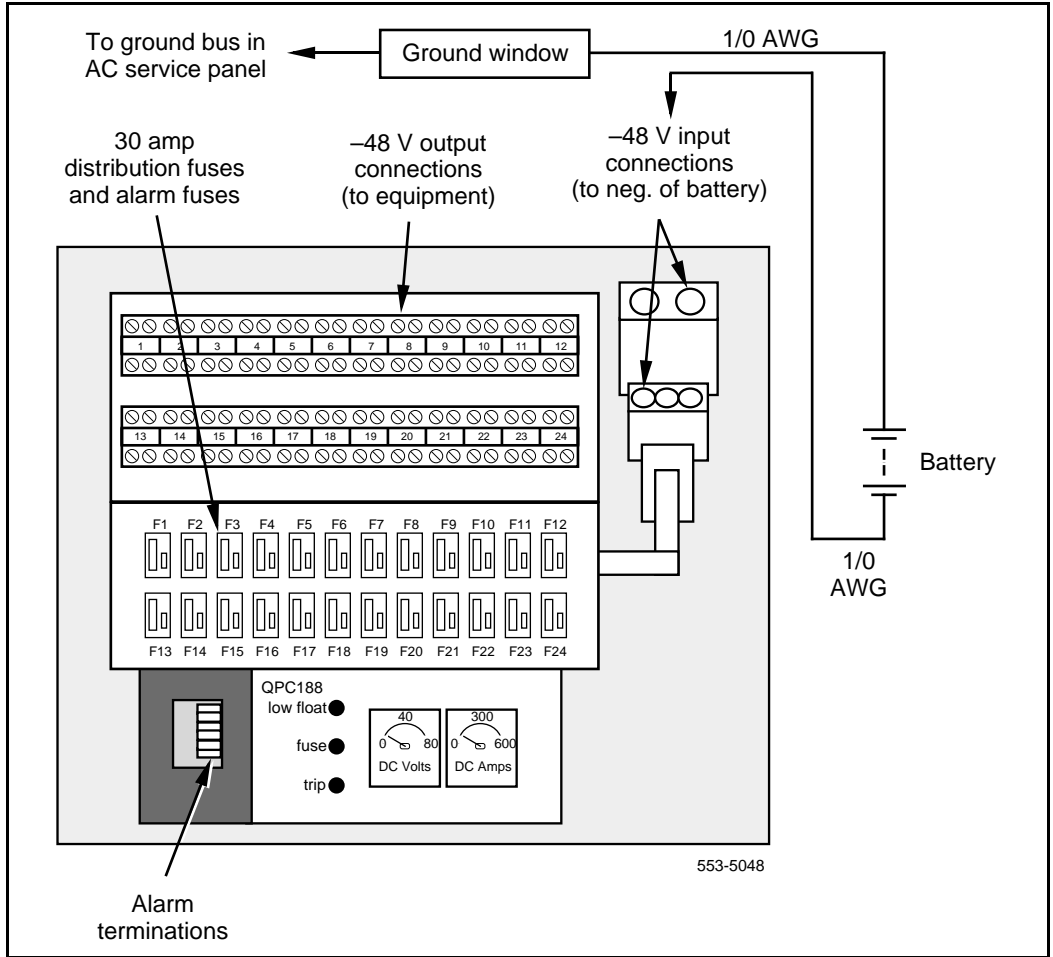

Table 50 on page 299 summarizes the connections in this procedure.

- 1 Unpack the distribution box. Check for damage to the unit or the meters. Report any damage to your supplier.
- 2 Mount the distribution box securely on a wall or other suitable surface:
 - Mount the unit with its bottom edge approximately 1.2 m (4 ft) from the floor within 1.8 m (6 ft) of the power plant.
 - If batteries are used, mount the unit close enough to the batteries to allow a voltage drop of not more than .25 V (.50 V on the loop) on the wire between the QBL12 and the batteries. See *Power Engineering* (553-3001-152) to calculate wire size.
- 3 Connect a black wire between the positive terminal of the power plant or battery string and the system ground source (ground window/LRE) (see Figure 125 on page 299).
- 4 Typically, this connection is to a ground window that is connected to the ground bus in the service panel.
- 5 Connect a red wire between the negative output terminal of the power plant or battery string and the -48 V input terminal in the QBL12.
- 6 Connect a #16 AWG wire between the positive terminal of the power plant or battery string and connector TB3-2 (+ SENSE) of the QBL12 (see Figure 126 on page 300).
- 7 Connect a #16 AWG wire between the negative terminal of the power plant or battery string and connector TB3-1 (- SENSE) of the QBL12.
- 8 Connect a #16 AWG wire between the DCON connection in the rectifier and connector TB3-6 (DCON) in the QBL12.

Note: A wire gauge smaller than #16 can be used if it does not provide more than 2.5 ohms of resistance across its entire length.

Table 50
QBL12 cabling

AWG (typical)	Color	From power plant or battery string	To
#1/0	Black	Positive terminal	System ground source
#1/0	Red	Negative terminal	-48 V input terminal in QBL12
#16	—	Positive terminal	TB3-2 (+ SENSE) in QBL12
#16	—	Negative terminal	TB3-1 (- SENSE) in QBL12
#16	—	DCON connection (in rectifier)	TB3-6 (DCON) in QBL12

Figure 125
QBL12 -48 V and ground connections

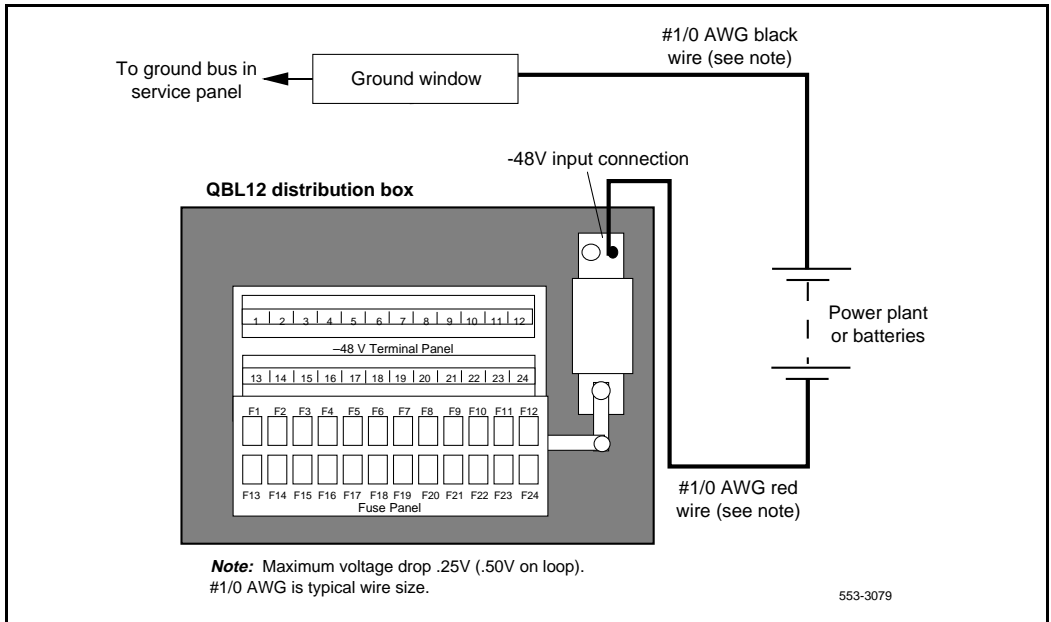
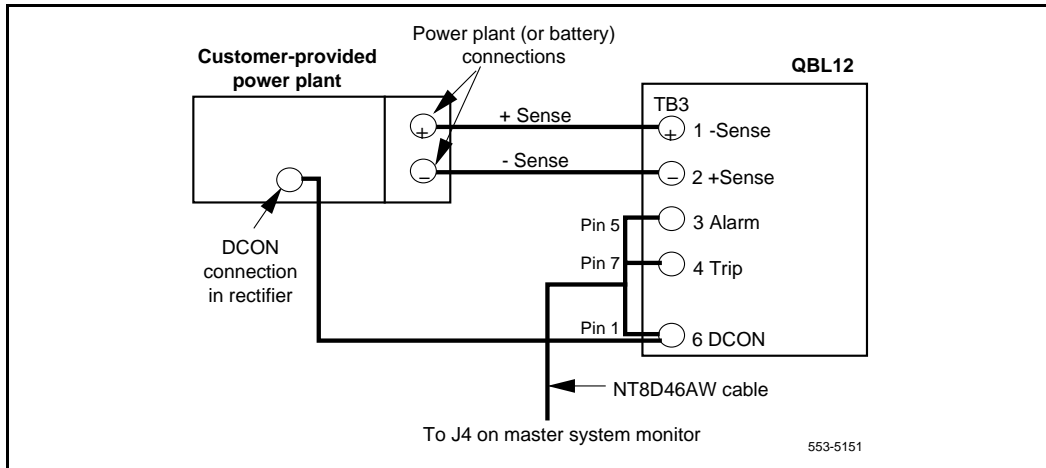

Figure 126
QBL12 SENSE and DCON connections



Installing a QBL15 power system

A power plant consisting of the QBL15 Power Distribution Box and NT6D52 or NT0R72 Switched Mode Rectifier can be used with Options 51C, and 61C. The NT6D52 are discontinued and are replaced by NT0R72 rectifiers.

One QBL15 distribution box is needed for every three NT6D52 or NT0R72 rectifiers; up to two QBL15 units can be used per system. This means a QBL15 power system can support a total of six rectifiers that support a maximum of twelve modules.

NT0R72 rectifiers operate on 240 V ac at 20 amps input current.

NT6D52 rectifiers operate on 240 V ac at 20 amps or 120 V ac at 30 amps.

Each rectifier comes equipped with a 20-amp cord and plug for use at 205/240 V ac. One IG-L6-20 or L6-20 receptacle is required for each rectifier.

Note: Do not exceed minimum and maximum input voltage limits of 180 to 250 V ac for NT6D52 rectifiers and 176 to 280 V ac for NT0R72 rectifiers. If only 240 V ac service is available, use a voltage regulation device so the 250 V ac limit cannot be exceeded.

Refer to Figure 127 on page 302 and Figure 128 on page 302 throughout the procedures for installing QBL15 distribution boxes and NT0R72 rectifiers.

The dimensions of the QBL15 components are given in Table 51 on page 301.

Table 51
Equipment dimensions

Equipment	Width		Depth		Height	
	cm	in.	cm	in.	cm	in.
NT6R52 Rectifier	48.3	19.0	35.6	14.0	25.4	10.0
NT0R72 Rectifier	48.3	19.0	35.6	14.0	25.4	10.0
NT7D12 Rectifier Rack	52.7	20.5	38.1	15.0	132.0	52.0
QBL15 Power Distribution Box	55.9	22.0	24.1	9.5	63.5	25.0

Figure 127
NT0R72 rectifier—front view

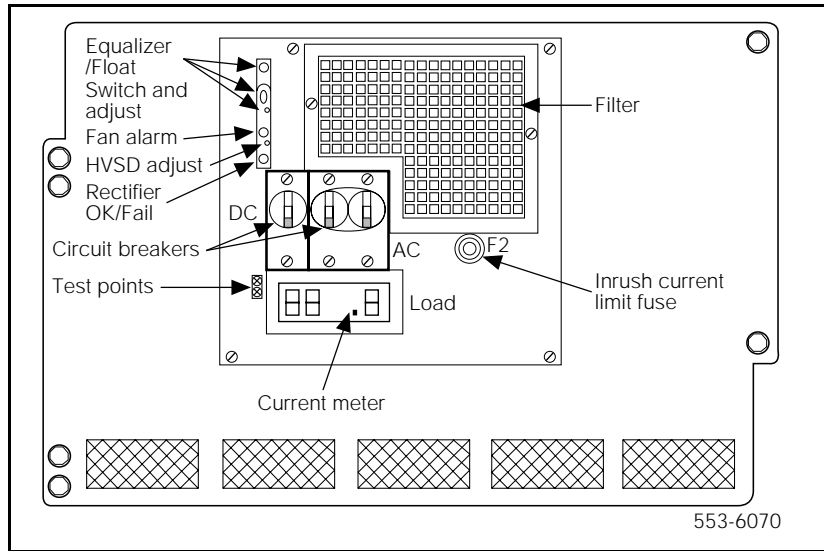
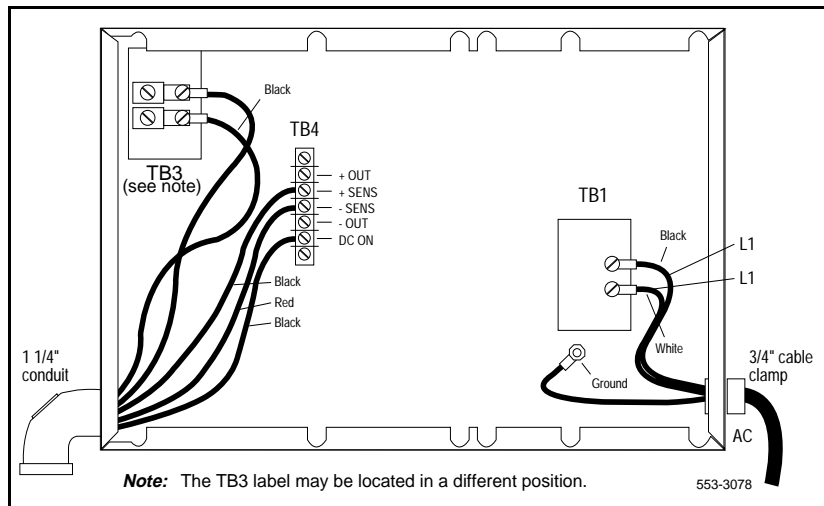

Figure 128
NT0R72 rectifier—rear view



Mounting NT0R72 rectifiers

Use this procedure to install NT0R72 rectifiers in an NT7D12 rectifier rack. The NT7D12 Rectifier Rack Assembly supports up to three rectifiers. Up to two racks can be used per system.

Each rectifier requires one NT7D1204 Mounting hardware kit and a NT7D1201 Rectifier Baffle assembly that consists of a set of support brackets and a heat baffle plate.

- 1 Position the rectifier rack. Install a bolt in each of the four holes at the base of the rack to secure the rack to the floor.
- 2 If not already installed, mount an NT7D1201 baffle assembly on the rack directly below the space for the rectifier (see Figure 129 on page 303).

Figure 129
NT0R72 rectifiers and NT7D12 rectifier rack

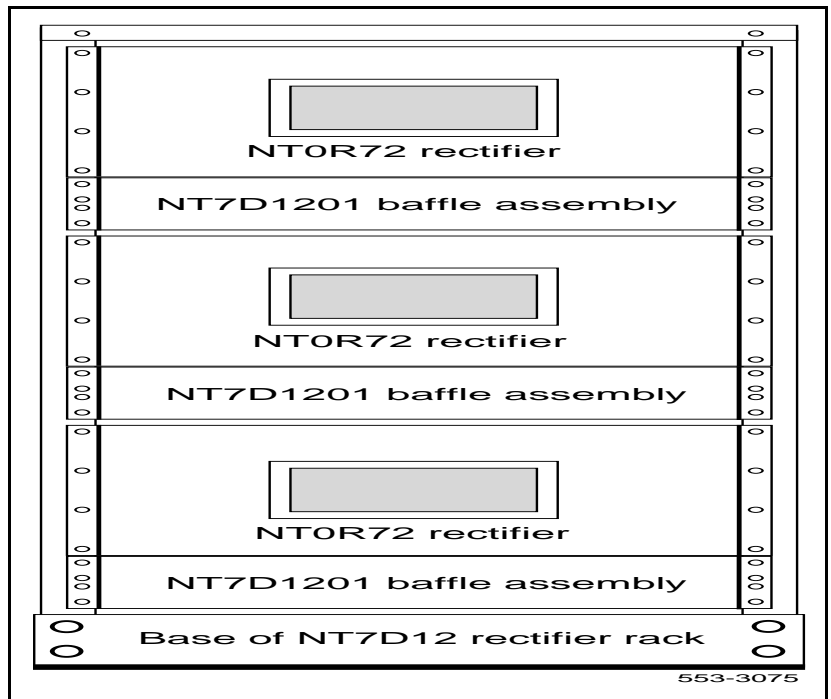

Secure the baffle assembly to the rack with the eight mounting screws provided (see Figure 130 on page 304).

Figure 130
NT7D1201 baffle assembly mounted in rack

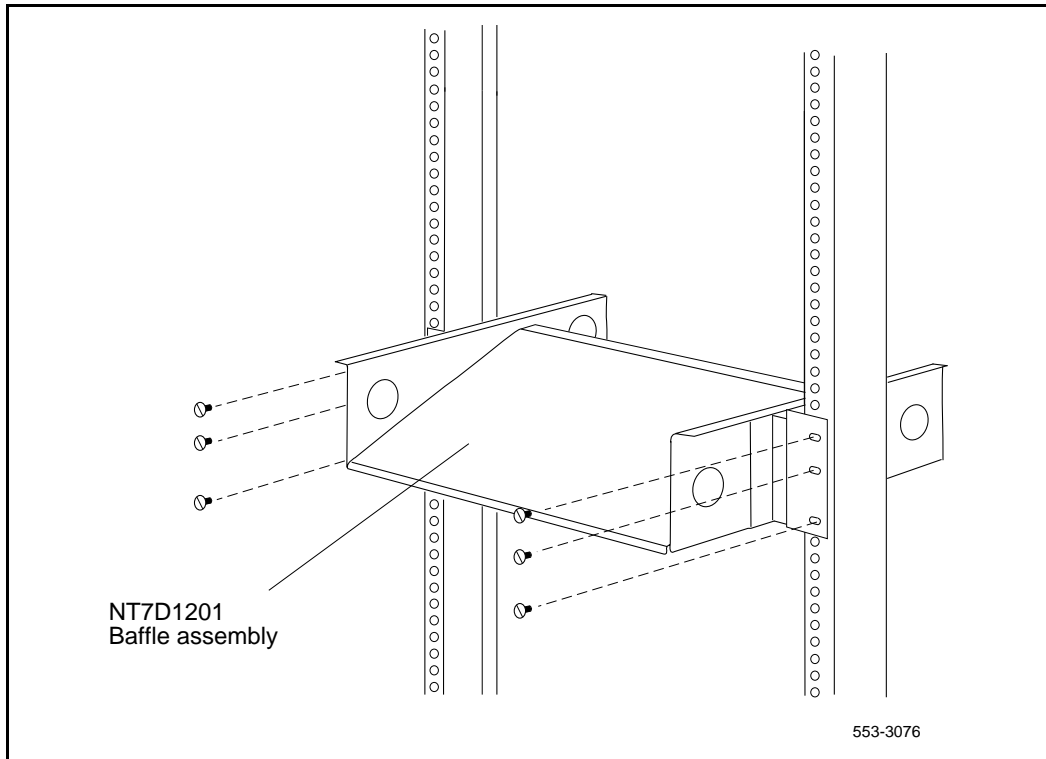

- 3 Attach NT7D1204 Mounting brackets to NT0R72 rectifiers (see Table 56 on page 335)
- 4 Mount the rectifier directly above the baffle assembly. Secure the rectifier to the rack with eight mounting screws and to the baffle assembly with two self-tapping screws (see Figure 131 on page 305).
Note: For proper weight distribution, install rectifiers starting at the *bottom* of the rectifier rack.
- 5 Remove the rear cover from the rectifier (leave the cover off until the rectifier and the QBL15 distribution box are connected).

Figure 131
NT0R72 rectifier mounted in rack

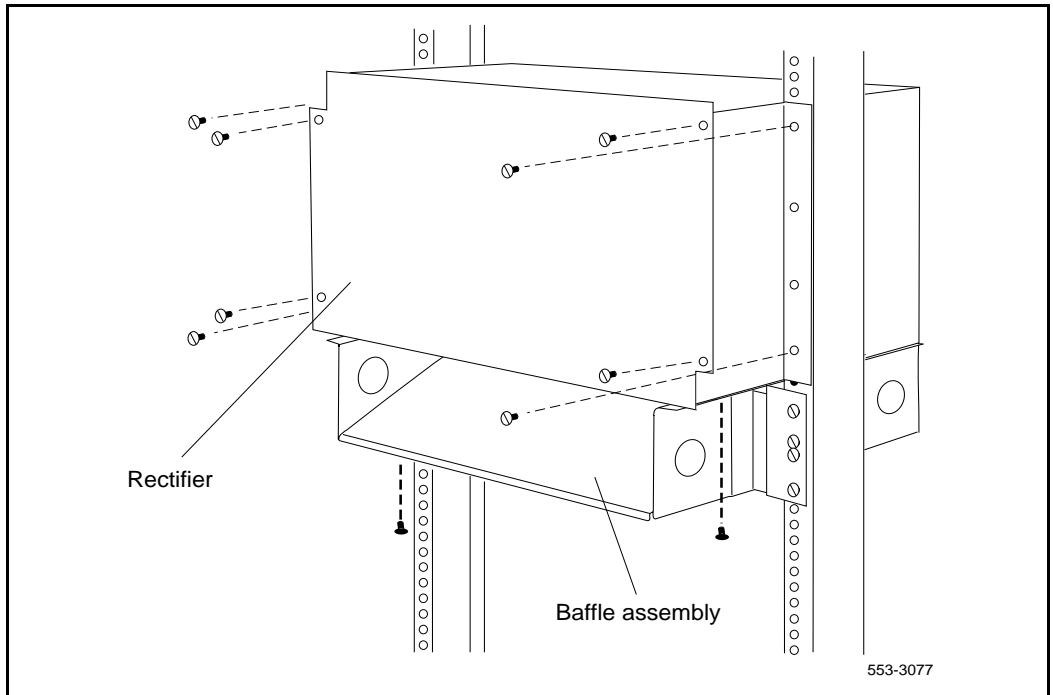

- 6** If the AC power cord is not installed, connect it to the rear of the rectifier as shown in Figure 128 on page 302. Do *not* connect it to the commercial power outlet at this point.
- 7** Perform continuity test from the ground prong on the power cord to the rectifier chassis.
- 8** Install a 1-1/4 in. conduit fitting as shown in Figure 128 on page 302.
- 9** Neatly secure the AC power cord and other external wiring to the rectifier rack with plastic cable ties.

Measuring and adjusting NT0R72 rectifiers

Use this procedure to measure and adjust the high voltage shutdown and float voltage for each NT0R72 rectifier.

Note: Although rectifiers are adjusted during manufacture, they should be measured and, if necessary, readjusted on site.

- 1 Set the AC BRKR switch on the front of the rectifier to OFF. If connected, disconnect the power cord.
- 2 If connected, disconnect the wires from the +SENS and -SENS terminals on TB4. Install one jumper from the +OUT terminal to the +SENS terminal and another jumper from the -OUT terminal to the -SENS terminal on TB4 (see Figure 128 on page 302).
- 3 Connect a voltmeter to the +OUT and -OUT terminals on TB4.
- 4 Plug the power cord into the commercial power outlet. Set the DC circuit breaker to ON and set the AC BRKR switch to ON, wait for the ON/RFA LED to turn GREEN.
- 5 Check the voltmeter. Slowly turn the FLT (float voltage adjustment, see Figure 127 on page 302) potentiometer clockwise and note the output voltage level where high voltage shutdown occurs. Record this voltage.

- 6 Slowly turn the FLT potentiometer slightly counterclockwise to lower the rectifier output voltage to a point just below the shutdown voltage. Reset the rectifier by setting the AC BRKR switch to OFF, then back to ON.

If the shutdown voltage you recorded does not fall within the range of acceptable values (see Table 52 on page 307), adjust the rectifier as follows:

- Turn the HVSD (high voltage shutdown adjustment, (see Figure 127 on page 302) potentiometer fully clockwise.
 - Check the voltmeter. Turn the FLT potentiometer until the voltmeter indicates the desired high voltage shutdown value.
 - Slowly turn the HVSD potentiometer counterclockwise and stop when the ON/RFA LED turns RED and the voltmeter reading drops to approximately 0 volts, indicating that the rectifier has shut down.
 - Turn the FLT potentiometer 1/4 turn counterclockwise.
 - Set the AC BRKR switch to OFF, then back to ON.
 - Check the voltmeter. Slowly turn the FLT potentiometer clockwise. The voltmeter reading should increase until the desired high voltage shutdown value is reached and then drop to 0 volts.
 - If necessary, repeat these adjustments until the desired level for high voltage shutdown is set.
- 7 Turn the FLT potentiometer to obtain the desired float voltage reading (see Table 52 on page 307). Set the AC circuit breaker to OFF and then back ON.
- 8 If wires were removed from the SENS terminals on TB4, remove the jumper straps and reconnect the black wire to +SENS and the red wire to -SENS. Store the jumper straps under the two screws provided adjacent to TB4.
- 9 Perform this procedure on each rectifier.

Table 52
Rectifier settings

Specification	Range
High voltage shutdown	-56.5 to -57.5 V
Float voltage	-51.5 to -54.0 V

Installing a QBL15 distribution box

Use this procedure to install and connect a QBL15 distribution box. When two QBL15 units are installed, connect the battery only to the distribution box with the functional circuit breaker.

Table 53 on page 308 summarizes the connections in this procedure.

- 1 Unpack the QBL15. Inspect the unit and the meters for damage.

	<p>DANGER The QBL15 distribution box weighs approximately 25 kg (50 lb.).</p>
---	--

- 2 Mount the distribution box securely on a wall or other suitable surface:
 - Mount the unit approximately 1.2 m (4 ft) from the floor.
 - If batteries are used, mount the unit close enough to the batteries to allow a voltage drop of not more than .25 V (.50 V on the loop) on the #1/0 AWG wire between it and the batteries.
- 3 Open the front cover of the QBL15 and remove the plate that covers the main circuit breaker (or main fuse—CRS200). Set the circuit breaker to OFF (or remove the fuse).
- 4 Install and connect a red #1/0 AWG wire between the negative terminal of the battery string and the negative input at the top of the circuit breaker (or fuse) in the QBL15 (see Figure 132 on page 309).
- 5 Install and connect a black #1/0 AWG wire between the positive terminal of the battery string and the positive bus in the QBL15.
- 6 Replace the plate that covers the main circuit breaker (or fuse). Leave the front cover open to connect the QBL15 to the rectifiers.

Table 53
Cabling to connect a QBL15 to batteries

AWG	Color	From battery string	To QBL15
#1/0	Red	Negative terminal	Negative input at the top of the circuit breaker (or fuse)
#1/0	Black	Positive terminal	Positive bus

Figure 132
QBL15 battery connections

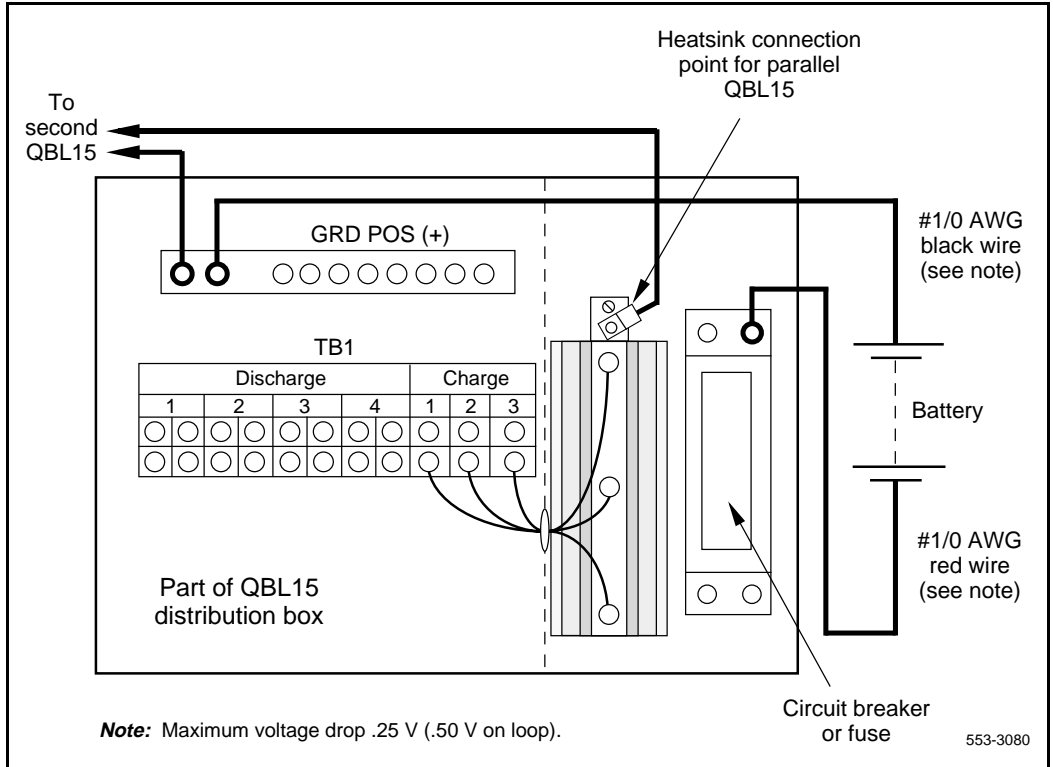

Adding a second QBL15

Table 54 on page 310 summarizes the connections in this procedure.

- 1 Unpack and mount the QBL15.
- 2 Open the front cover of the unit and remove the plate that covers the main circuit breaker (or main fuse—CRS200).
- 3 Install and connect a red #4 AWG wire between the initially installed QBL15 and the second QBL15.
 - Before you install the wire, crimp a ring lug on each end, or use a compression fitting like the type on the positive bus.
 - The connection point on each unit is a 1/4-20 stud located at the top of the large heatsink (see Figure 132 on page 309). Note that there are already four wires connected to the stud.
- 4 Install and connect a black #4 AWG wire between the initially installed QBL15 and the second QBL15. The connection point on each unit is a compression fitting, labeled GND POS (+), on the positive bus.
- 5 Do not set the main circuit breaker of the second QBL15 to ON (or do not reinsert the main fuse in the box).
- 6 Replace the plate that covers the main circuit breaker (or main fuse). Place a tag labeled "CIRCUIT BREAKER IS NON-FUNCTIONAL" on the circuit breaker in the second QBL15.

Table 54
Cabling to add a second QBL15

AWG	Color	From first QBL15	To second QBL15
#4	Red	Stud on the heatsink	Stud on the heatsink
#4	Black	GND POS (+)	GND POS (+)

Connecting NT0R72 rectifiers to the QBL15 distribution box

All wiring between the QBL15 and the rectifier must be contained in the same conduit. A 1-1/4 in., or equivalent, flexible-type conduit is required. Install the conduit in one of the conduit openings on the top of the QBL15 (choose one of the openings near the rear so the door can be closed).

One NT6D54 field wiring kit is required for every three rectifiers connected to a QBL15. The kit contains one male connector (A0290885), two mounts for cable ties (P0594300), four connector contacts (A0290890), and two cable ties (P0567232).

Table 55 on page 313 summarizes the connections for this procedure.

- 1 In each rectifier, install #4 AWG wires for –48 V and 48 V return connections (see Figure 133 on page 314):
 - The wires must not be longer than 30 m (100 ft).
 - For 48 V return, connect a black wire from terminal 2 on TB3 in the rectifier to the positive bus in the QBL15.
 - For –48 V, connect a red wire from terminal 1 on TB3 in the rectifier to charge terminal 1, 2, or 3 on TB1 in the QBL15.

- 2 In each rectifier, install #22 AWG wires for + SENS, – SENS, and DCON connections (see Figure 133 on page 314). (A full pair of #24 AWG station wire can be used instead of one, #22 AWG wire. Wrap appropriately colored tape near the ends of each station-wire pair.)

Note: The (+) and (–) sense lead pairs from a rectifier must connect to TB3 in the QBL15, with the first rectifier connected to TB3-1 and TB3-2 (+ and – sense, respectively). A second rectifier connects to TB3-3 and TB3-4, etc.

 - Connect a black wire between the + SENS terminal on TB4 in the rectifier and terminal 1, 3, or 5 on TB3 in the QBL15.
 - Connect a red wire between the – SENS terminal on TB4 in the rectifier and terminal 2, 4, or 6 on TB3 in the QBL15.
 - Connect a blue wire to the DCON terminal on TB4 in the rectifier. This wire will connect to the field wiring kit (installed in the next step) in the QBL15.

- 3 Install an NT6D54 field wiring kit in the QBL15 (see Figure 134 on page 315).
 - Remove approximately 6 mm (1/4 in.) of insulation from the end of the blue DCON wires from terminal 5 on TB4 in the rectifiers.
 - With an AMP 90296-type crimping tool, install one connector contact (A0290890) on the skinned wires.
 - Label the wires DCON 0, DCON 1, or DCON 2 as appropriate.
 - Insert the connector contact in the male connector (A0290885).
 - Connect the male connector to the female connector (A0290886) on the end of the NT8D46AT cable to the system monitor.
 - Secure the DCON connectors to the left inside panel of the QBL15 with the cable tie mounts and cable ties supplied with the kit.
- 4 Make sure all rectifiers in the system are properly connected.
- 5 Set the AC circuit breakers on all rectifiers to OFF and all circuit breakers on all Meridian 1 columns to OFF.
- 6 Set the CB0 circuit breaker on just one Meridian 1 column to ON to establish a minimum load.
- 7 Adjust rectifier float voltage as follows:
 - Set the AC and DC circuit breaker on a single rectifier to ON.
 - At the QBL15, connect a voltmeter to the (+) and (–) test points (located with the QPC188 Battery Monitor). Adjust the FLT potentiometer on the energized rectifier to obtain the desired float voltage reading, ± 5 mV dc.
 - Set the AC circuit breaker to OFF.
- 8 Repeat step 7 for all remaining rectifiers in the system.
- 9 Disconnect all rectifier power cords until the system is placed in service.

Table 55
Cabling to connect NT0R72 rectifiers to the QBL15 distribution box

AWG	Color	Connection	From rectifier	To QBL15
#4	Black	48 V return	Terminal 2 on TB3	GRD POS (+)
#4	Red	-48 V	Terminal 1 on TB3	Terminal 9, 10, or 11 on TB1
#22	Black	+ sense	+ SENS terminal on TB4	Terminal 1, 3, or 5 on TB3
#22	Red	- sense	- SENS terminal on TB4	Terminal 2, 4, or 6 on TB3
#22	Blue	DCON	DCON terminal on TB4	Field wiring kit; see Figure 132 on page 309

Figure 133
Rectifier to QBL15 connections

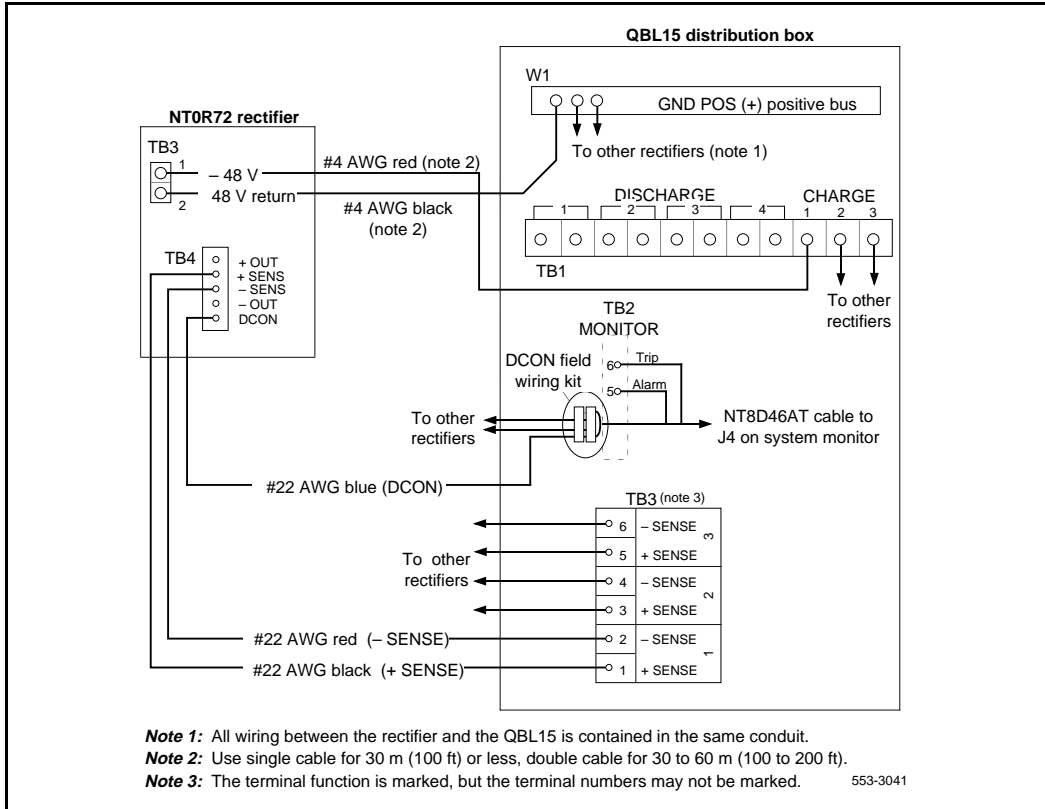
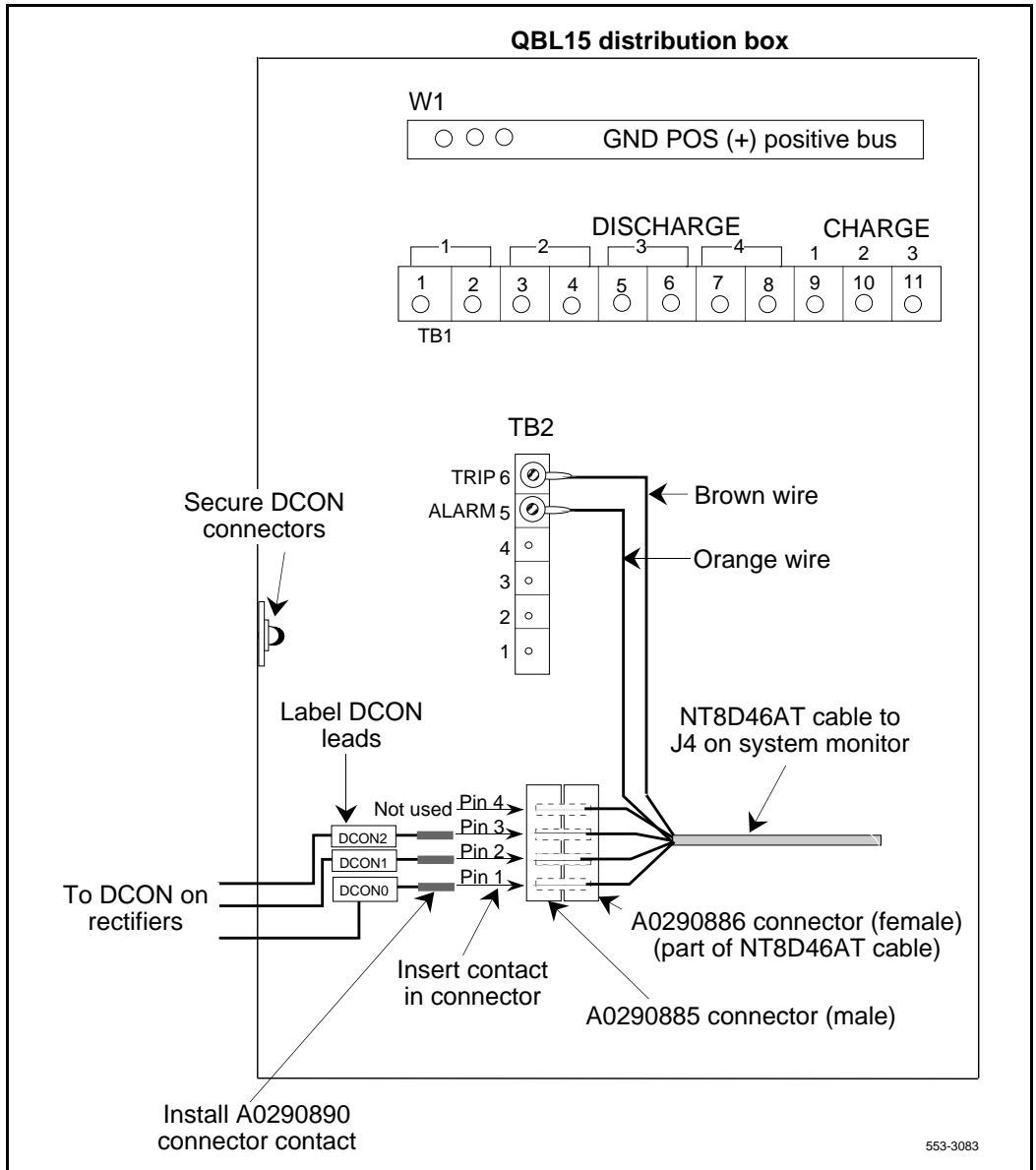

Figure 134
NT6D54 field wiring kit connections



Installing a QCA13 power plant

The QCA13 DC Power Plant can be used with larger Option 61C configurations.

The QCA13 consists of fusing and distribution hardware, monitoring and control equipment, and up to four NT5C03 rectifiers. Up to two supplemental cabinets can be added, with up to four rectifiers in the first supplemental cabinet and up to two rectifiers in the second cabinet, for a total of ten rectifiers and a total system capacity of 500 amps.

Each of these rectifiers operates from a nominal 208/240 V ac at 23/21 amps. Each rectifier is generally hard-wired to the commercial power source. One 30-amp circuit is required for each rectifier.

To install a QCA13, follow the instructions provided with the QCA13 equipment.

Installing safety ground/protective earth and logic return wiring

The single point ground required by the system can be an isolated ground (IG) bus or AC equipment ground (ACEG) bus in the service panel or transformer. The system is to be connected to safety ground/protective earth in accordance with national requirements. For international use, the system is to be connected to safety ground/protective earth in accordance with Paragraph 2.5 of EN60950/IEC950.

Note: Refer to *Installation Planning* (553-3001-120) for a complete description of approved ground sources and methods. Insulated ground wire must be used for system grounding.

Depending on the distances between columns and the service panel, safety ground/protective earth wiring can be daisy-chained or run independently from each column to the service panel.

Figure 135 on page 318, Figure 136 on page 319, Figure 137 on page 320, and Figure 138 on page 321 show the ACEG as the single point ground and safety ground/protective earth wiring in daisy-chain configurations.

Multiple-column systems often use a logic return equalizer (LRE) as the point where the logic return wires from different columns are consolidated before connecting to the single point ground. The NT6D5303 large LRE (usually used with DC power systems) is available from Nortel Networks.

The LRE used with the QBL12 is a copper bus bar that is mounted on a wall next to the QBL12. The positive bus in the QBL15 is used as the LRE. The LRE used with the QCA13 is located on top of the QCA13 cabinet. The LRE used with the NT6D82 is a copper bus bar mounted in the control/distribution panel or the power plant.

Figure 135 on page 318, Figure 136 on page 319, Figure 137 on page 320, and Figure 138 on page 321 show the logic return points and wiring configurations.

Figure 135
NT8D62 Ground and logic return distribution—NT6D82 Power System

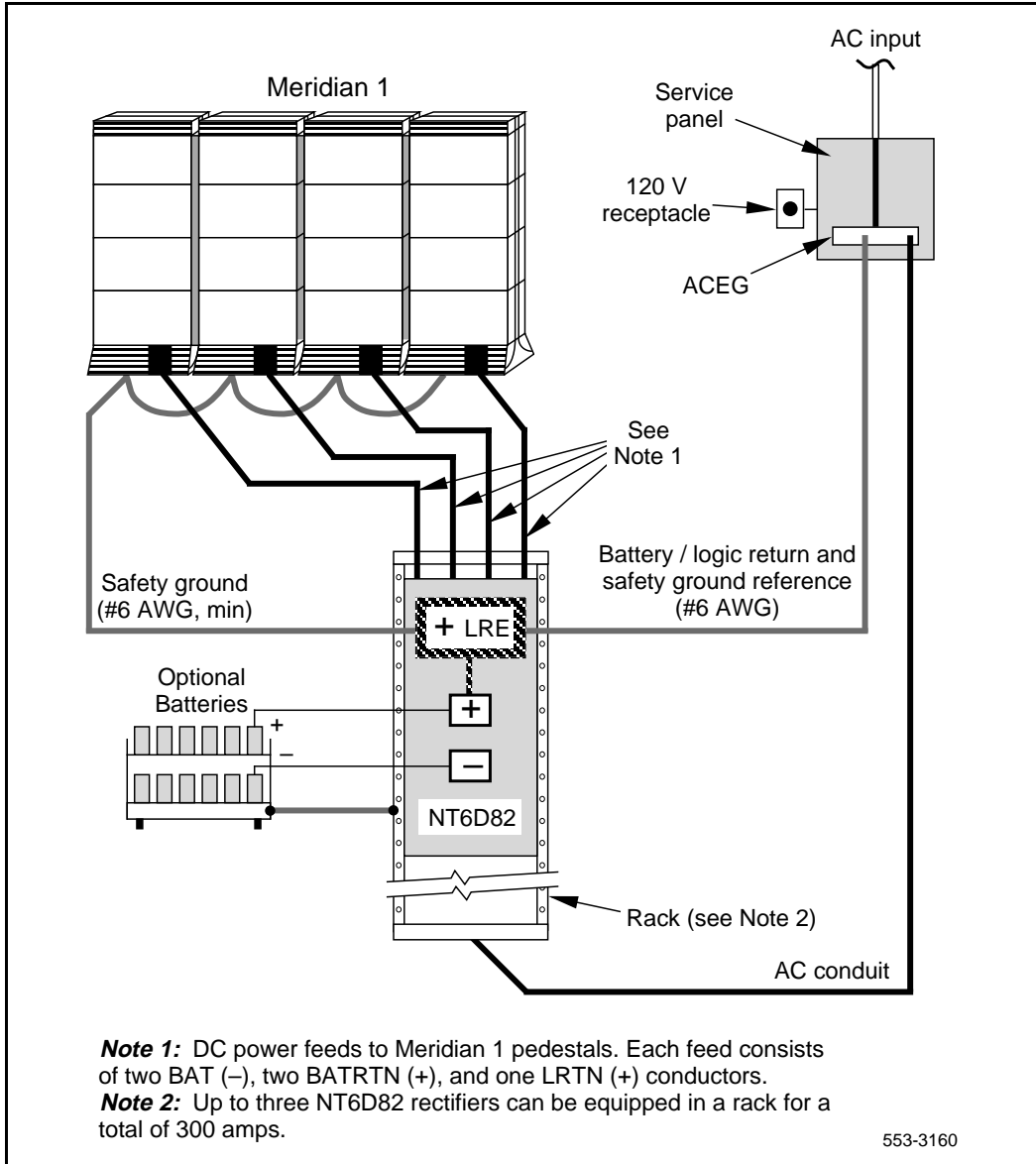

Figure 136
QBL12 ground and logic return distribution

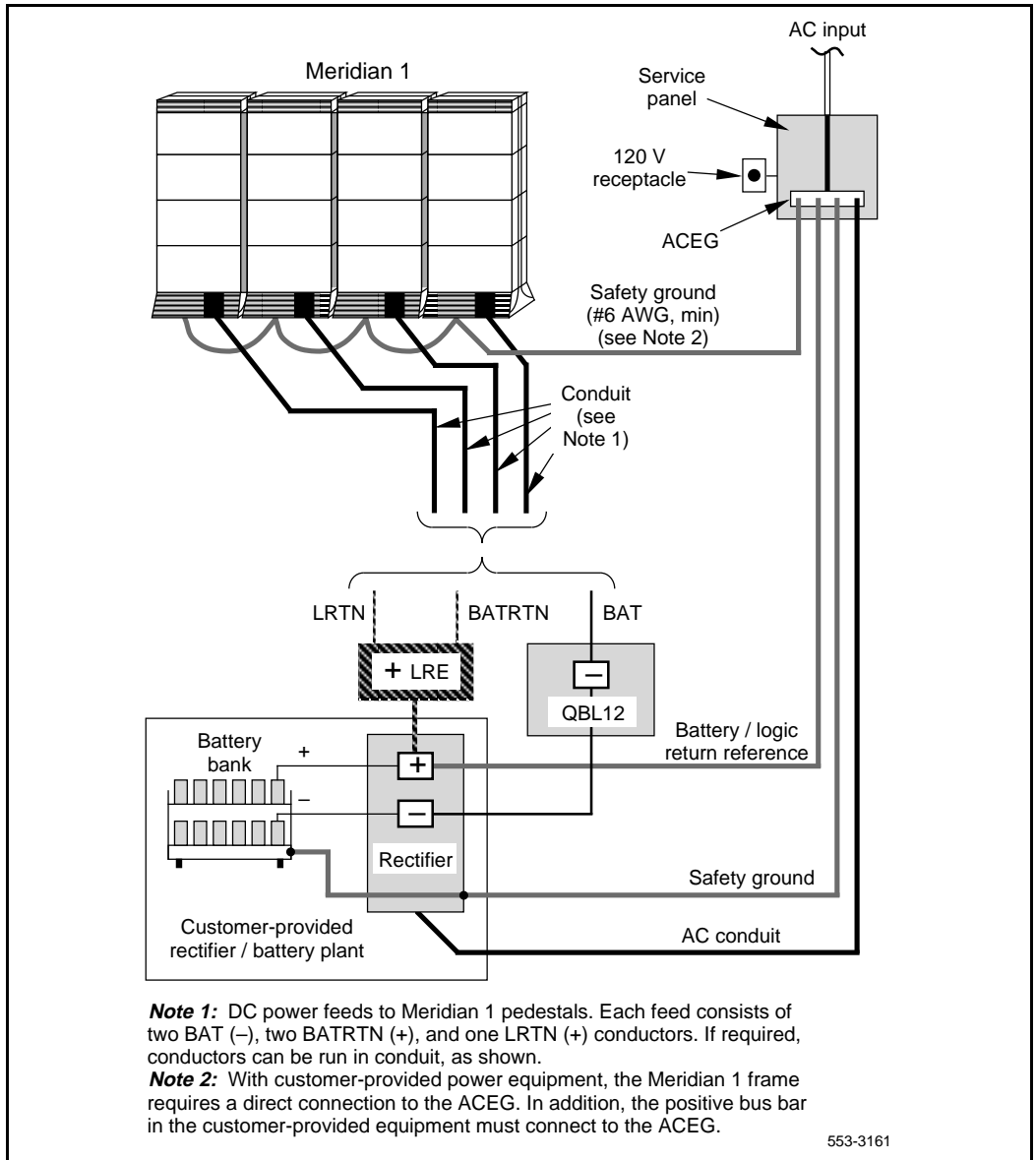

Figure 137
QBL15 ground and logic return distribution

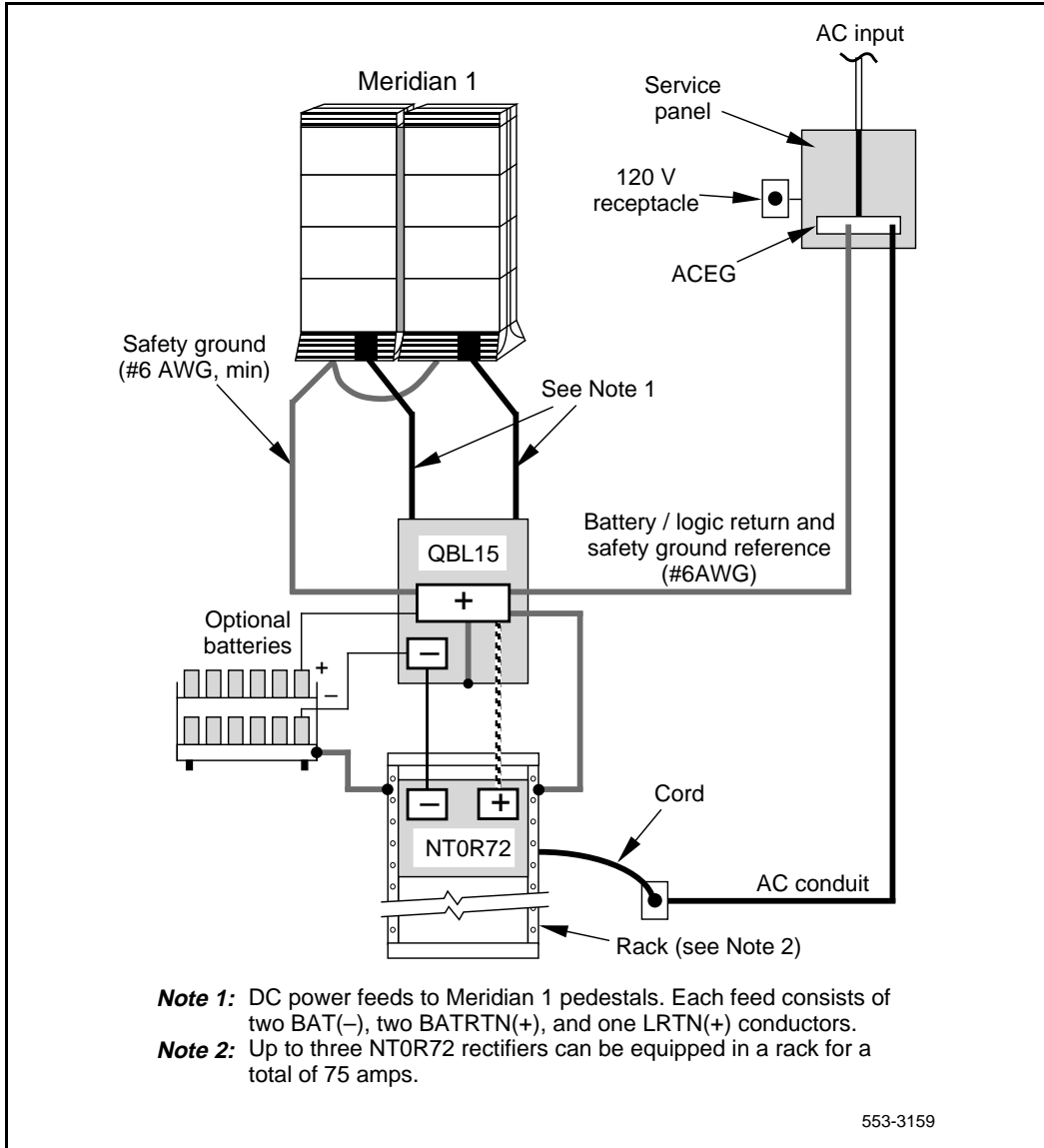
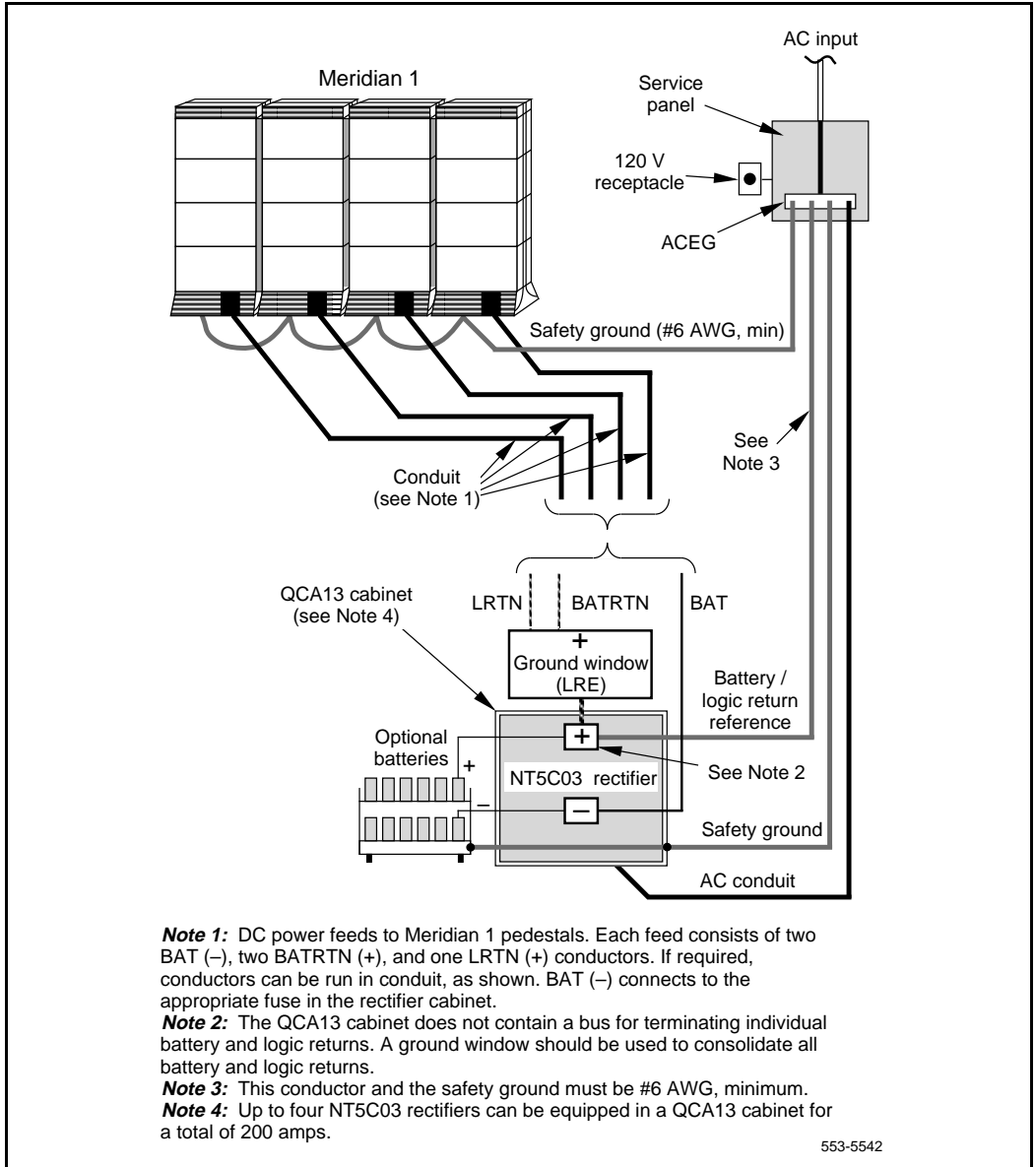

Figure 138
QCA13 ground and logic return distribution



Installing safety ground/protective earth wiring



CAUTION

System Failure

Failure to follow grounding procedures can result in unsafe or faulty equipment. See *Installation Planning* (553-3001-120) for a complete description of approved ground sources and methods.

- 1 Make sure all pedestals are disconnected from the power source.
 - **With an NT682, QBL12, or QCA13**, remove the associated 30-amp fuse.
 - **With a QBL15**, set the circuit breaker to OFF (or remove the main fuse).

- 2 At the rear of the pedestal, remove the plastic safety cover over the terminal block to access the safety ground/protective earth lugs (leave the cover off until all pedestal connections are made):
 - Loosen the three screws holding the cover.
 - Lift the cover up, then over the three mounting screws on the front panel of the cover.

- 3 Connect the safety ground/protective earth wire:

Note: Insulated ground wire must be used for system grounding.

 - a. **For a single-column system**, connect a #6 AWG wire from the ground source in the service panel to a ground lug on the pedestal.
 - b. **For a multiple-column system**, connect a #6 AWG wire from the ground source in the service panel to a ground lug on the closest column. Daisy-chain #6 AWG ground wires from one pedestal to the next, connecting all of the columns as illustrated in Figure 139 on page 323 (or run a #6 AWG wire from the ground source to each column individually).

Note: With the NT7D67CB PDU, the safety ground/protective earth wire must be routed within the cable-tie saddles and under the cable restraint bar at the base of the pedestal.

Figure 139
Column ground lug daisy chain connection

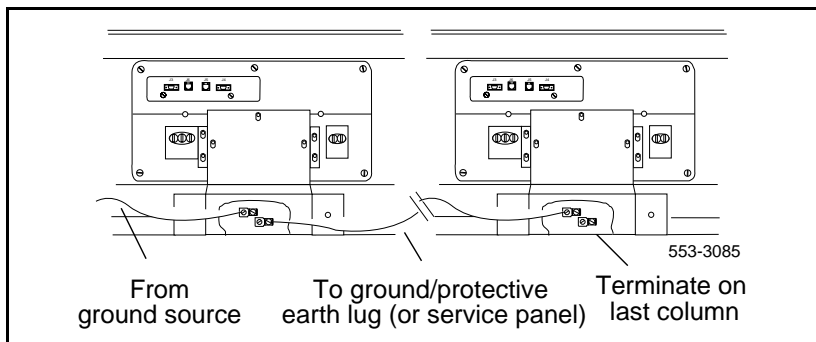

- 4 Place a warning tag (WARNING—TELEPHONE SYSTEM GROUND CONNECTION—DO NOT DISCONNECT) on the connection at the ground source.

Connecting the PDU

A readily accessible disconnect device for input power is required.



CAUTION **System Failure**

DC power for the NT7D09 Pedestal must be provided with circuit protection of 30 amps for the BAT 0,1 and BAT 2,3 feeds (see Figure 140 on page 324).

Circuit breakers must be located next to each other and labeled to show that both must be shut off to remove all power to the system.

A maximum loop drop of two volts is allowed between the PDU, or junction box, and the external power equipment. See Table 141 on page 325 for allowable wire sizes. See *Power Engineering* (553-3001-152) for detailed information on calculating wire size.

Figure 140
Circuit protection for the PDU

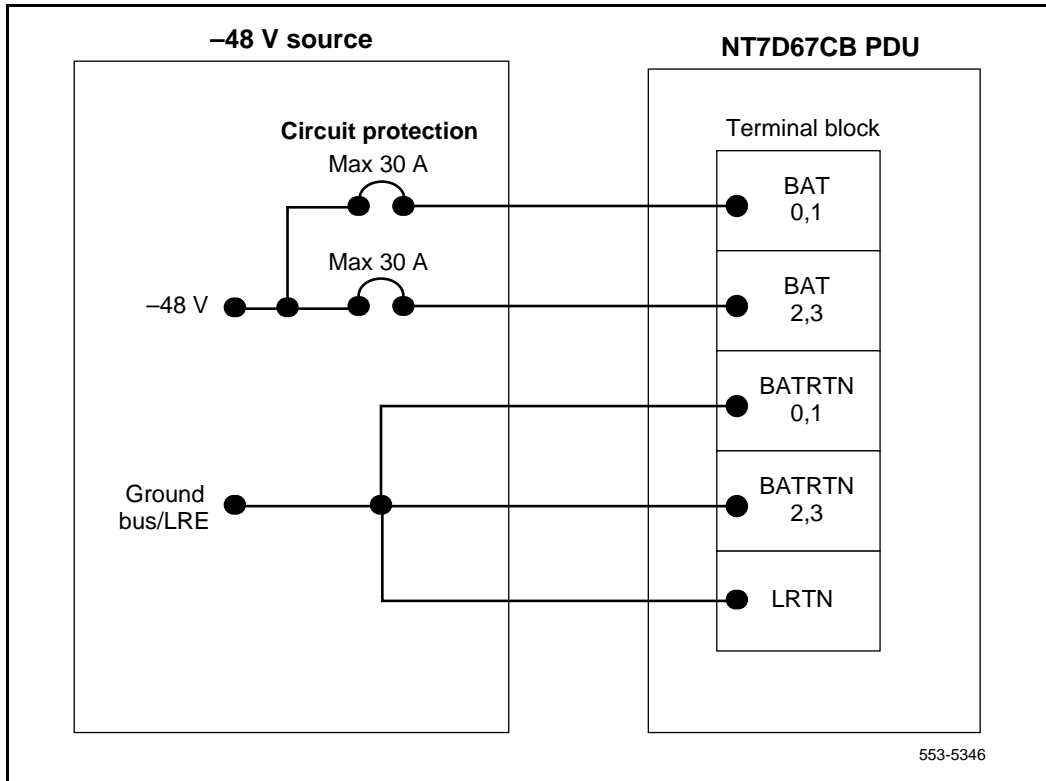

Figure 141
Wire gauge requirements with two 30-amp feeds (five wires)

Length	#8 AWG	#6 AWG	Single #4 AWG	Double #4 AWG
0–3 m (10 ft)	Yes	Yes	Yes	Yes
3–6 m (20 ft)	Yes	Yes	Yes	Yes
6–9 m (30 ft)	Yes	Yes	Yes	Yes
9–12 m (40 ft)	Yes	Yes	Yes	Yes
12–15 m (50 ft)	Yes	Yes	Yes	Yes
15–18 m (60 ft)	No	Yes	Yes	Yes
18–21 m (70 ft)	No	Yes	Yes	Yes
21–24 m (80 ft)	No	Yes	Yes	Yes
24–27 m (90 ft)	No	No	Yes	Yes
27–30 m (100 ft)	No	No	Yes	Yes
30–60 m (200 ft)	No	No	No	Yes
over 60 m (200 ft)	No	No	No	No

Note 1: Two 30-amp feeds are typically adequate for a column with four modules (five wires total—two 30-amp feed pairs plus logic return).

Note 2: If dual conduit is used, the wires must be run in battery/battery return pairs, with one pair in one conduit and the other pair, plus logic return, in the other conduit.

Legend: Yes= Wire size is adequate for the distance.
 No= Wire size has too high a voltage drop and is inadequate for the distance.

The following equipment is located in the rear of each pedestal (see Figure 142 on page 326) in Meridian 1 columns:

- The PDU distributes power to the entire column.
- The field wiring terminal provides the connection point for wiring brought into the pedestal.
- A circuit breaker is provided for each module in the column and for the blower unit.

Note: All column circuit breakers will trip if a column thermal overload is detected or a DC-power low-voltage condition is sensed.

- The system monitor checks the column temperature, cooling system status, and system voltage status, and controls alarms and line transfer states accordingly.

Figure 142
DC power equipment in the rear of the pedestal—NT7D67CB PDU

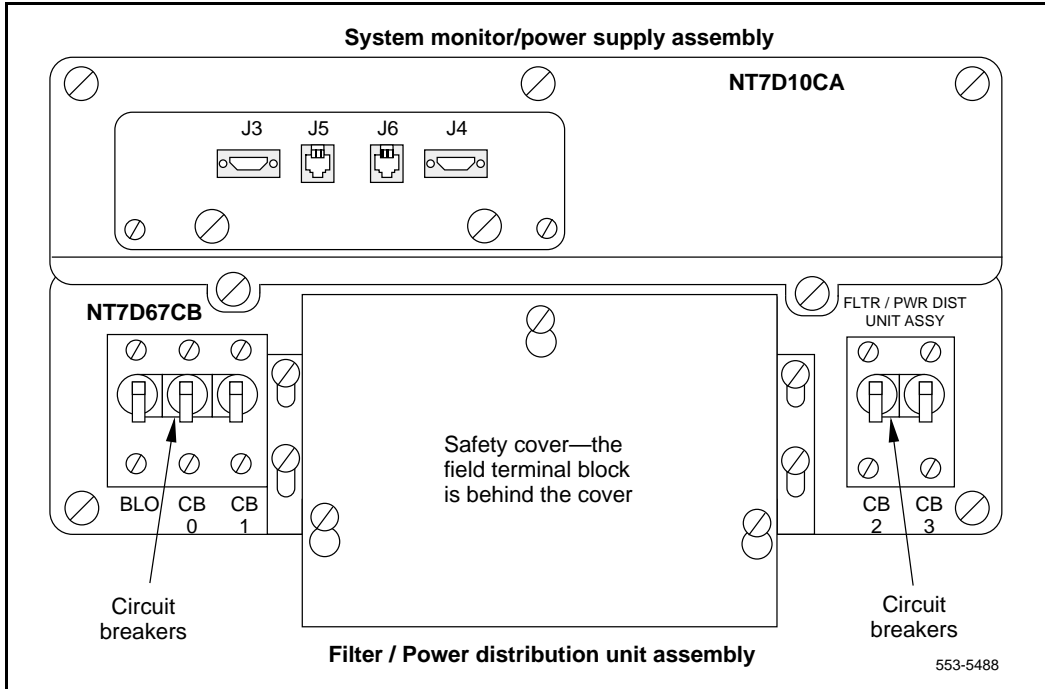

With the NT7D67CB PDU, the safety ground/protective earth wires and all wiring to the terminal block in the PDU must be routed within the cable-tie saddles and under the cable restraint bar at the base of the pedestal (see Figure 143 on page 327).

Conduit is not required with the NT7D67CB PDU. However, 1-1/4 or 3/4 in. conduit can be used if local codes or individual installations require it. Conduit can be routed down through the column from overhead racks or up through the floor. Conduit clamps and the hardware to fasten the conduit are provided in the pedestal. If the NT7D0902 Rear Mount Conduit Kit is used, conduit can enter from the rear of the column (above the floor).

Figure 143
Cable routing in the rear of the pedestal—NT7D67CB PDU

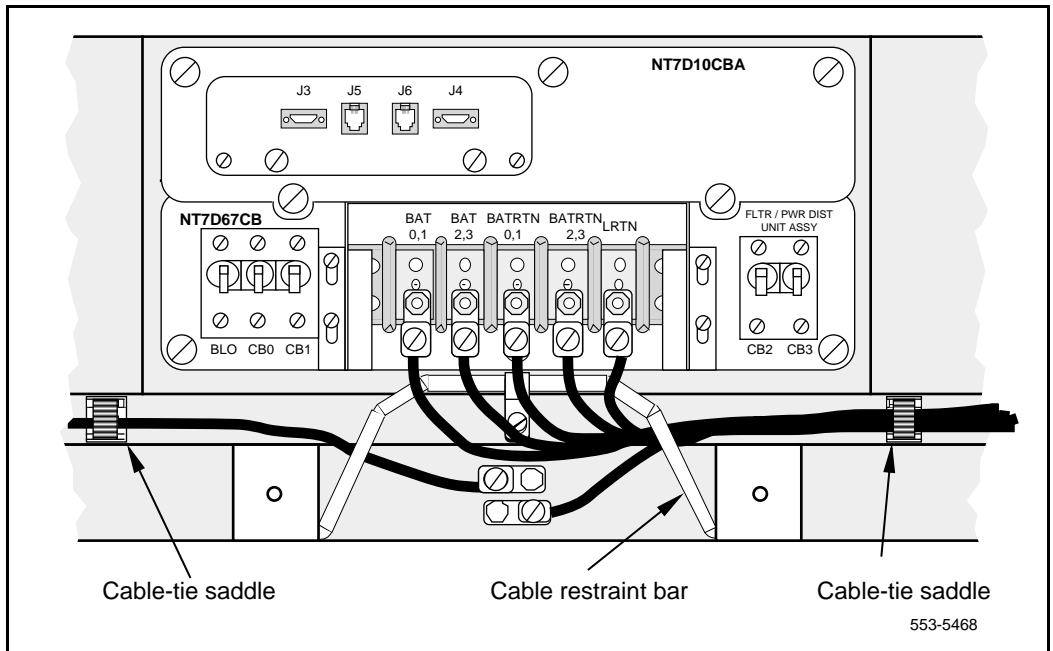

Preparing the NT7D67CB PDU

When a system is shipped, a set of screws secures the leveling bracket at the rear of the NT7D67CB PDU to protect the PDU from vibration damage during transit. The shipping screws should be removed during initial installation.

- 1** **1** For access to the rear of the PDU, temporarily remove the blower unit in the front of the pedestal:
 - Turn the screws on the front of the blower unit counter-clockwise.
 - Grasp the lip at the top edge of the blower unit. Slide the unit out of the glides and onto the bottom ledge of the pedestal. Lift the unit out of the pedestal. (Keep the blower unit in an upright position.)

- 2** **2** Remove the two shipping screws holding the PDU to the vertical shield in the pedestal.

- 3** **3** Reinstall the blower unit:
 - Set the blower unit on the bottom ledge of the pedestal.
 - Tilt the back of the blower unit up slightly so it will slide into the pedestal glides (you may need to lift the unit). Gently push the unit into position.
 - Tighten the screws on the front of the blower unit.

Connecting power to the NT7D67CB PDU

To connect the external power system to the PDU, use the following procedure for each column (this procedure gives the connections for a four-module column).

Note: All wiring to the PDU must be routed within the cable-tie saddles and under the cable restraint bar at the base of the pedestal.

- 1 If a junction box is used, insert the conduit from the junction box into one of the conduit access holes in the pedestal.

Connect the wires from the junction box to the matching connections on the terminal block on the PDU:

- Connect the red wires to BAT 0,1 and BAT 2,3.
- Connect the black wires to BATRTN 0,1 and BATRTN 2,3.
- Connect the remaining wire (orange or white) to LRTN.

Note: If a junction box is used, the connections described in steps 2 through 4 apply to the junction box rather than the PDU.

- 2 Connect the red BAT (–48 V) wires:
 - At the power plant:
 - a. **For an NT6D82**, connect the wires to the first two circuit breakers in the main control/distribution panel (see Figure 144 on page 331).
 - b. **For a QBL12 or QCA13**, connect the wires to the first two available 30-amp fuse output connections on the –48 V terminal panel (see Figure 145 on page 332).

Note: Each 30-amp fuse output has two connection points on the distribution panel. Only one 30-amp connection point is required for every two modules; typically, #6 AWG is adequate (#4 AWG can be used).

- c. **For a QBL15**, connect the wires to terminals 1, 2, 3, or 4 (DISCHARGE) on TB1 (see Figure 146 on page 333).
- At the PDU, connect the wires to the terminal block (one wire feeds two modules):
 - For modules 0 and 1, connect to BAT 0,1.
 - For modules 2 and 3, connect to BAT 2,3.
- 3** Connect the black BATRTN (48 V return) wires:
 - At the power plant:
 - a. **For an NT6D82**, connect two wires to the ground bus/LRE.
 - b. **For a QBL12 or QCA13**, connect two wires to the LRE.
 - c. **For a QBL15**, connect two wires to the positive bus.
 - At the PDU, connect the wires to the terminal block (one wire feeds two modules):
 - For modules 0 and 1, connect to BATRTN 0,1.
 - For modules 2 and 3, connect to BATRTN 2,3.
- 4** Connect the LRTN wire (orange or white):
 - At the power plant:
 - a. **For an NT6D82**, connect the wire to the ground bus/LRE.
 - b. **For a QBL12 or QCA13**, connect the wire to the LRE.
 - c. **For a QBL15**, connect the wire to the positive bus.
 - At the PDU, connect the wire to LRTN on the terminal block.
- 5** Reinstall the plastic safety cover over the terminal block:
 - Lower the front panel over the mounting screws on the PDU.
 - Tighten the three screws holding the cover.
- 6** Close the covers on the power plant.

Figure 144
PDU to NT6D82 connections

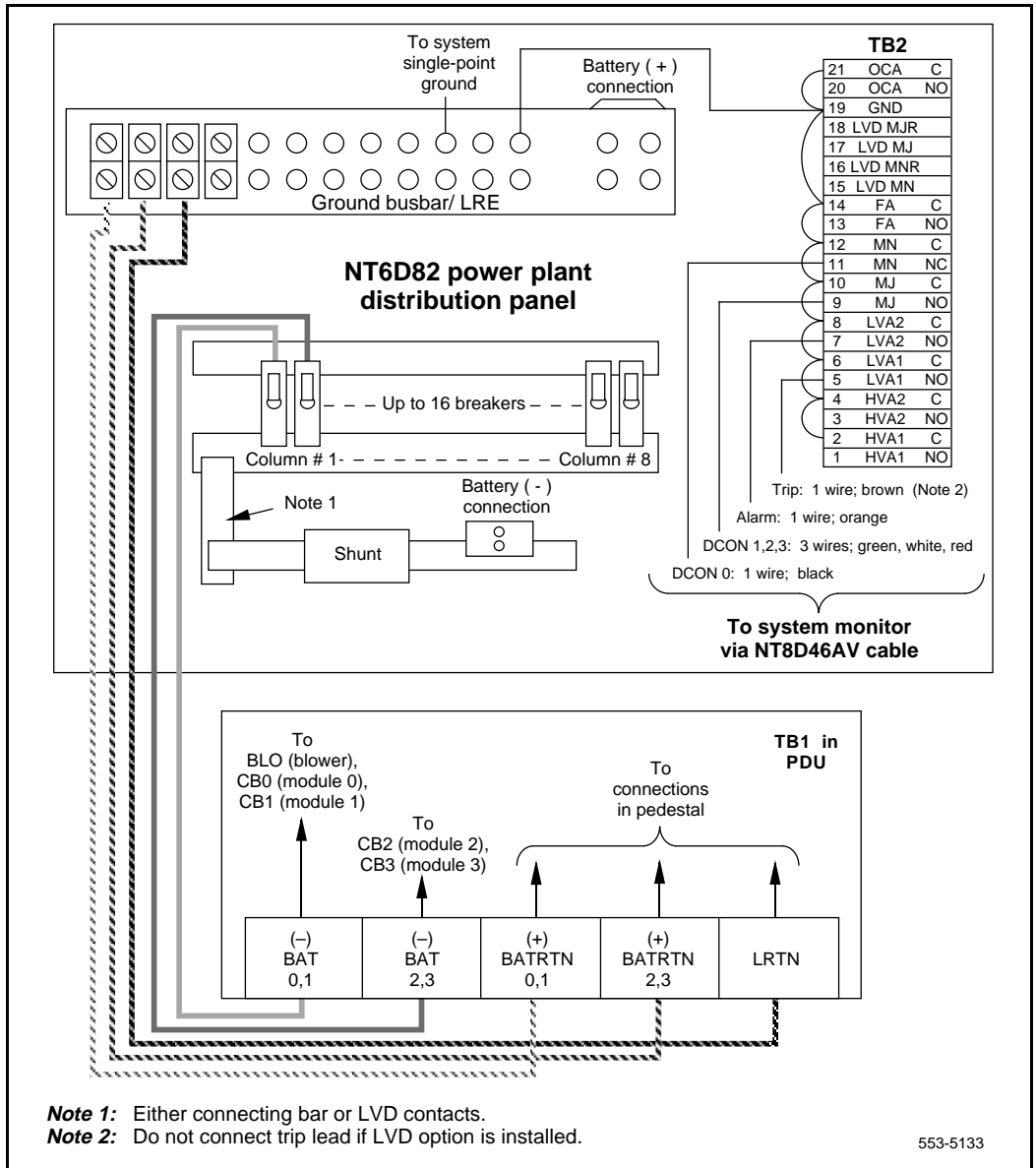

Figure 145
PDU to QBL12 or QCA13 connections

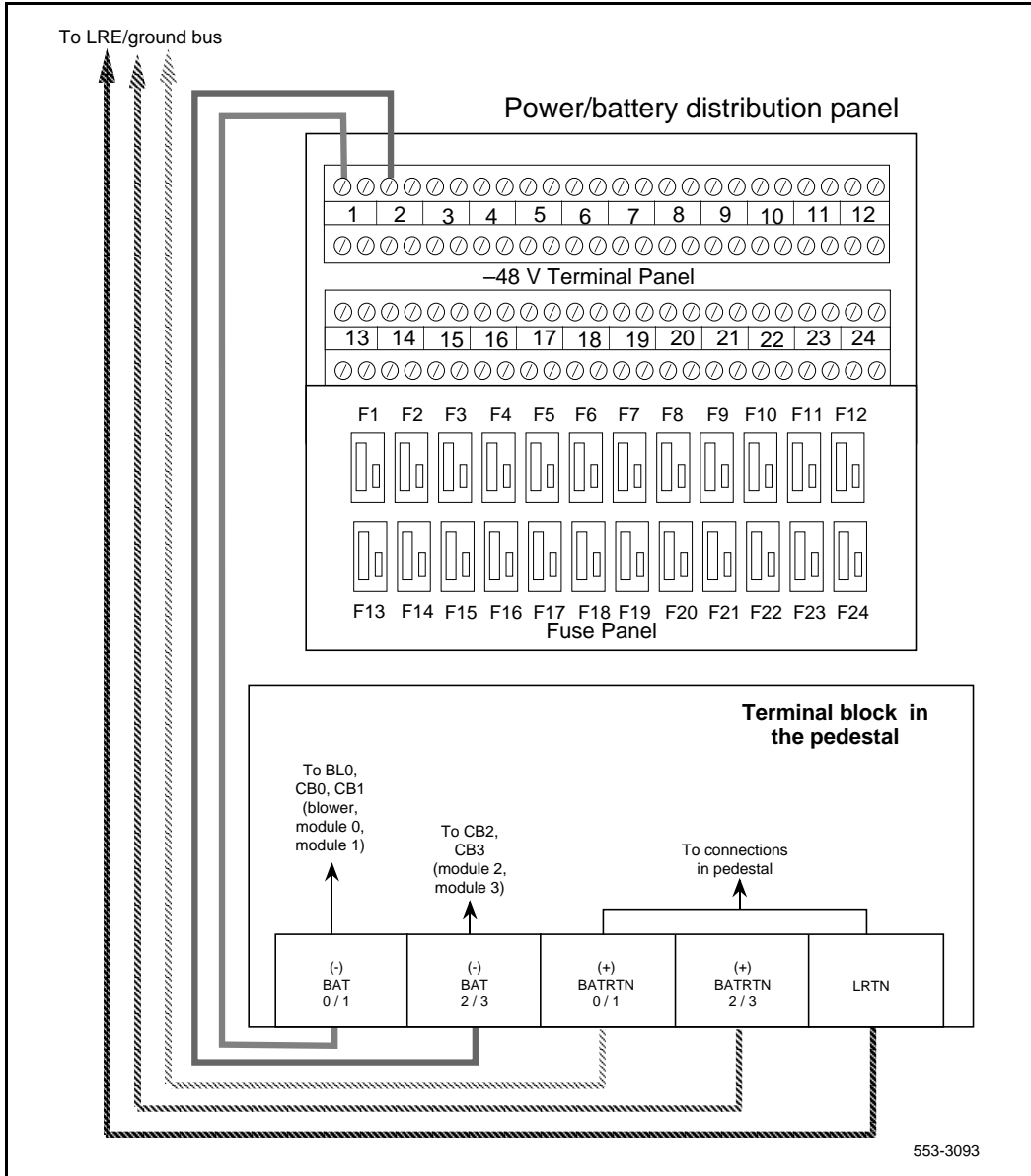
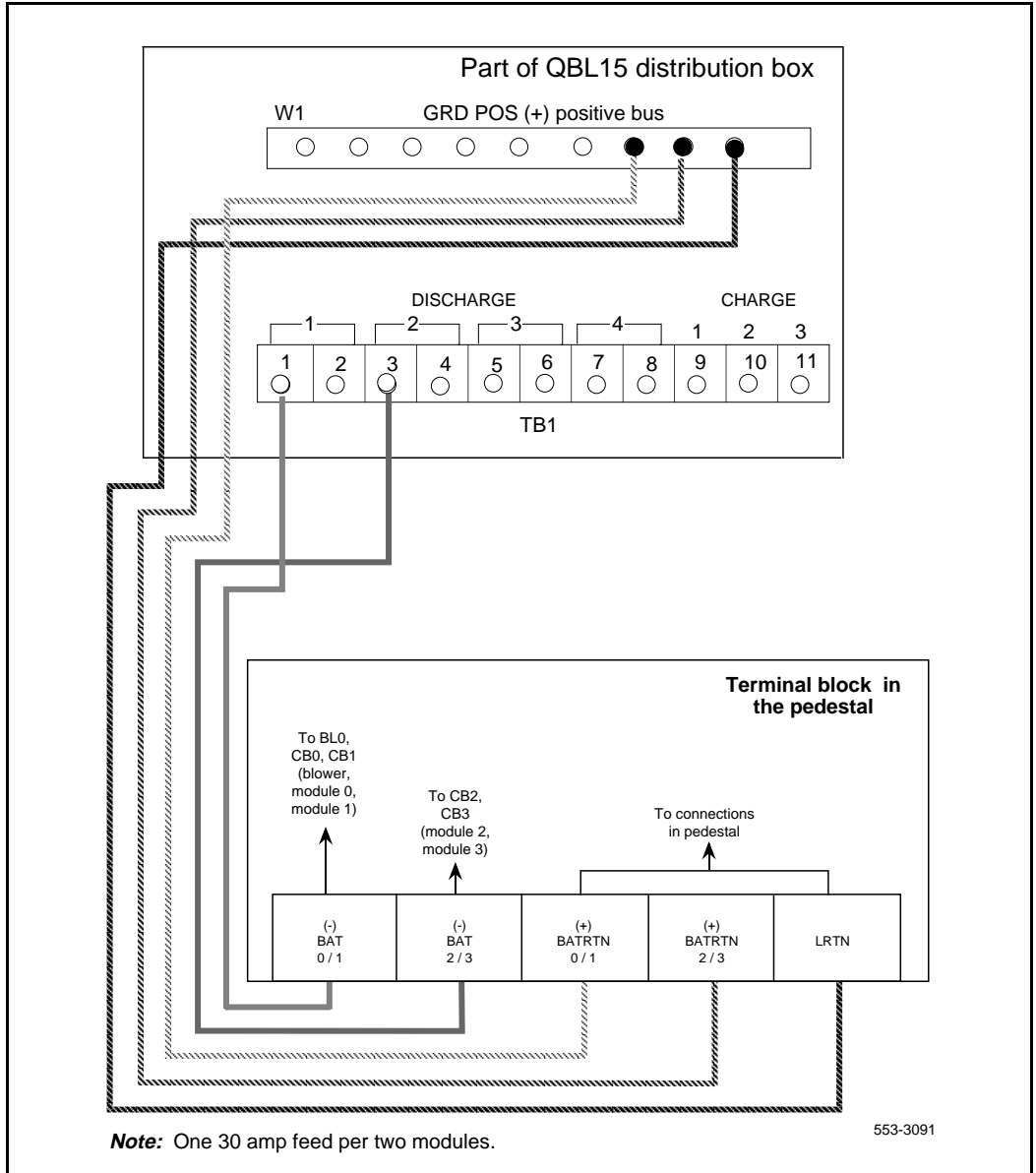

Figure 146
PDU to QBL15 connections



Connecting the NT8D22 system monitor

See “Configuring the system monitor” on page 93 to

- configure system monitor switch settings
- cable the system monitor to the SDI port
- cable system monitors in a multiple-column Meridian 1
- cable the system monitor to PFTUs or external alarms

Use the following cables to extend the alarm and trip leads from connector J4 on the master system monitor to the external power equipment (conduit is not required):

- **For an NT6D82**, use an NT8D46AV cable (see Table 56 on page 335).
- **For a QBL12**, use an NT8D46AW cable (see Table 57 on page 336).
- **For a QBL15**, use an NT8D46AT cable (see Table 58 on page 337).
- **For a QCA13**, use an NT8D46AV cable (see Table 59 on page 337).

An NT8D46BV cable, 20 m (64 ft), or NT8D46CV cable, 33 m (100 ft), can be used instead of the NT8D46AV cable. Connections are the same as the NT8D46AV cable.

Table 56
NT6D82 alarm and trip lead connections—NT8D46AV cable

Color	Description	Connection at TB2 in the NT6D82
BL	DCON 0	MNA (NO), position 11
R	DCON 1*	MJA(NO), position 9
W	DCON 2*	MJA(NO), position 9
GR	DCON 3*	MJA(NO), position 9
OR	Alarm	LVA2 (NO), position 7
BL	not used	—
BR	not used	—
Y	not used	—
V	not used	—
* Connect the red, white, and green wires together at MJA.		

Table 57
QBL12 alarm and trip lead connections—NT8D46AW cable

Color	Description	Connection at TB3 in the QBL12
BL	DCON 0*	Terminal 6
R	not used	—
W	not used	—
GR	not used	—
OR	Alarm	Terminal 3
BL	not used	—
BR	Trip	Terminal 4
Y	not used	—
V	not used	—
* Also terminate the DCON connection from the rectifier on terminal 6.		

Table 58
QBL15 alarm and trip lead connections—NT8D46AT cable

Color	Description	Connection at TB2 in the QBL15
BL	DCON 0	*
R	DCON 1	*
W	DCON 2	*
GR	not used	—
OR	Alarm	Terminal 5
BL	not used	—
BR	Trip	Terminal 6
Y	not used	—
V	not used	—

* The A0290885 male connector in the QBL15 connects the DCON wires from the rectifiers to the A0290886 female connector on the end of the NT8D46AT cable. See “Connecting NT0R72 rectifiers to the QBL15 distribution box” on page 311 to install the A0290885 connector.

Table 59
QCA13 alarm and trip lead connections—NT8D46AV cable

Color	Description	Connection at TSA in the QCA13
BL	not used	—
R	not used	—
W	not used	—
GR	not used	—
OR	Alarm	Terminal 50
BL	not used	—
BR	Trip	Terminal 49
Y	not used	—
V	not used	—

Appendix B: Backplane cabling in NT8D37 modules

Content list

The following are the topics in this section:

Reference list	339
Backplane configurations	339
I/O panel connections	342
Connecting lines and trunks	343
Backplane cable expansion	357
NT8D11 CE/PE Modules	357
NT8D37 IPE Modules	357

Reference list

The following are the references in this section:

- *Administration* (553-3001-311)

Backplane configurations

In the backplane configurations in NT8D37 (AA and DC vintage) IPE Modules, some slots on the backplane are fully cabled to accommodate 24 tip and ring pairs (three cable connectors). Most of the backplane slots, however, accommodate 16 pairs (two cable connectors).

In the 12-cable configuration for the backplane in the NT8D37 IPE Module, cables D, H, N, and U are not used. Those cables are used in the 16-cable expanded configuration (NT8D37BA, EC, and later vintage modules).

Figure 147 on page 340 shows the backplane slots, and Figure 148 on page 341 shows the external I/O panel designations.

Figure 147
NT8D37 backplane cable designations for 12-cable configuration

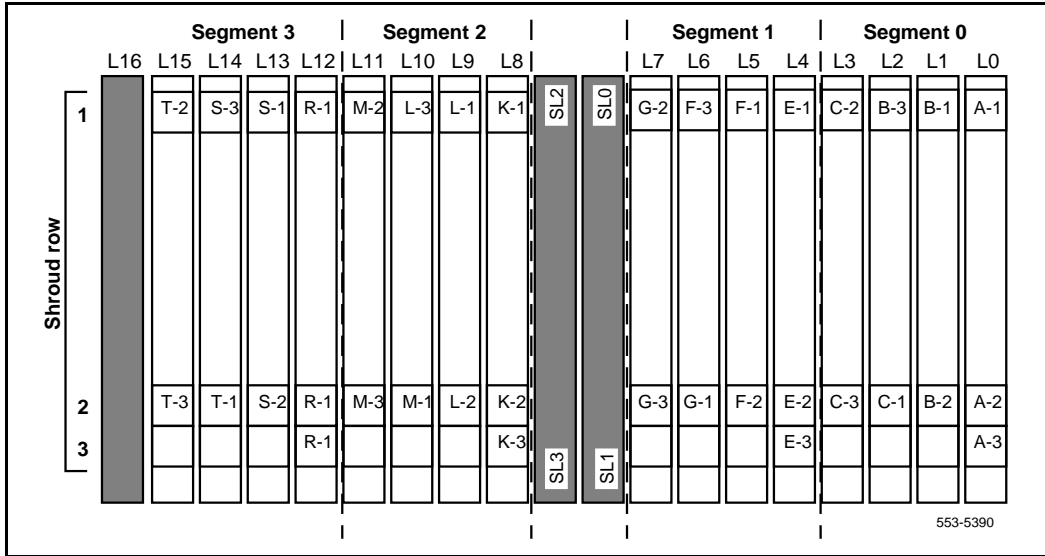
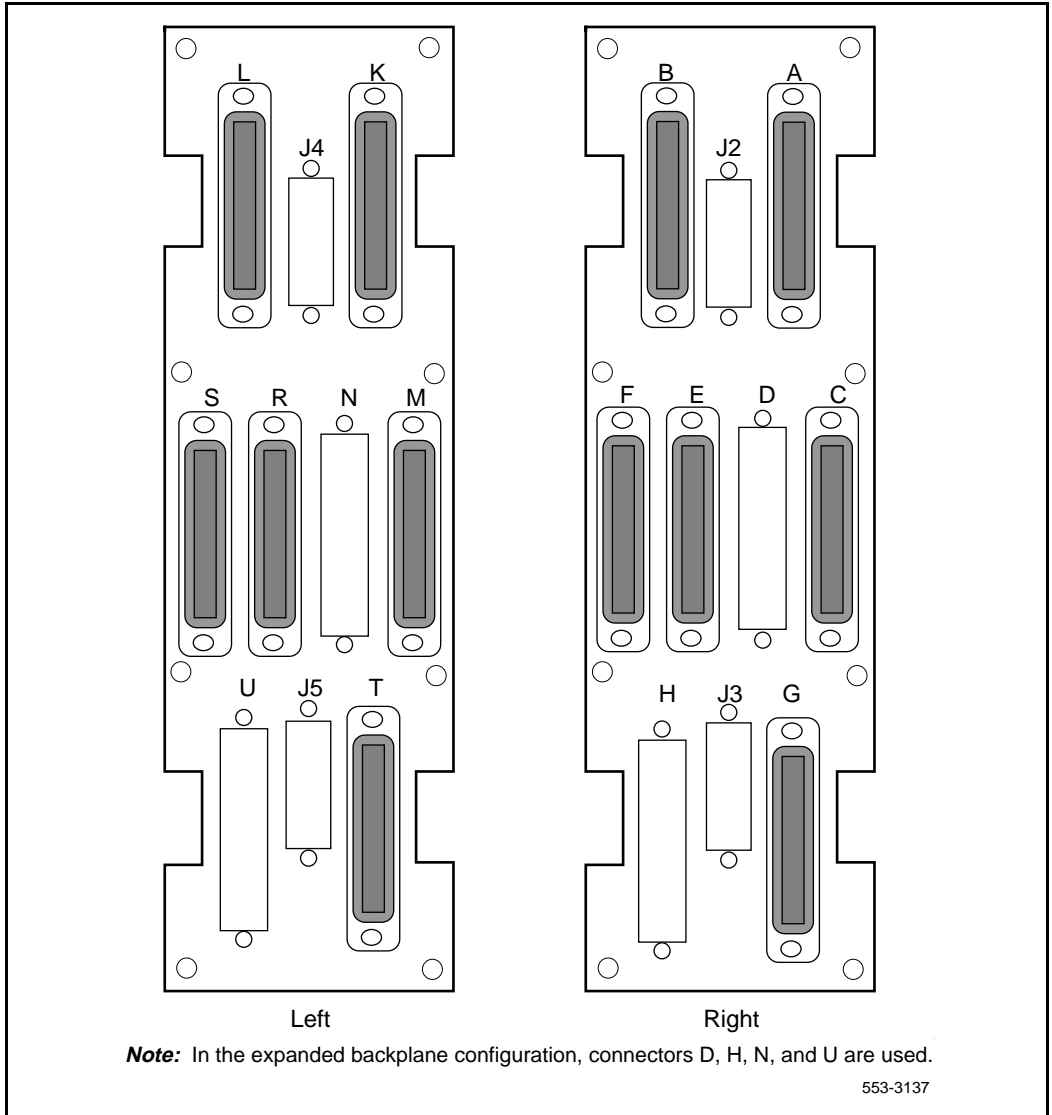

Figure 148
NT8D37 IPE Module I/O panels for 12-cable configuration



I/O panel connections

Note: The corner vertical channels in the rear of the module are outside of the EMI shield. Cables in those vertical channels must be shielded, and must enter and exit the EMI-shielded area through I/O panels and adapters.



DANGER OF ELECTRIC SHOCK

Tip, ring, A, B, E, M, ESC, and ESCG connections can be considered to be Telecommunications Network Voltages (TNV).

- 1 Select an appropriate number of NE-A25B (or equivalent) cables long enough to run from the I/O panels on the rear of the module to the MDF.
- 2 Attach a tag that shows the module number and the I/O connector designation to both ends of each cable.
- 3 Connect each cable to the appropriate connector on the I/O panel and run the cables to the MDF.
- 4 Terminate each cable on the cross-connect block designated with the appropriate module number.
Note: Refer to "Planning and designating the Modular Distribution Frame (MDF)" on page 71 for information on the MDF layout.
- 5 Make sure all cables are neatly run, properly seated, and secured with cable ties.

Connecting lines and trunks

Throughout this procedure, make sure wiring is not reversed and is on the proper terminals. Allow enough slack in the wiring to allow tracing and to reconnect wires if they break at the terminal.

- 1 Extend incoming wiring (such as cables from the central office or wiring from a recorded announcement machine) to the MDF and terminate them on separate connecting blocks.
- 2 Assign and record terminal numbers (TNs) for each line or trunk. Determine the location of the line or trunk connection and its assigned TN from the work order or assignment records.
- 3 Connect each line and trunk to the TN using cross-connecting wire (typically 24 AWG type-Z wire). Table 60 on page 343 lists pair-termination tables for line and trunk cards in NT8D37 (AA and DC vintage) IPE Modules.
- 4 Cross-connect incoming wiring and lines and trunks at the MDF.

Table 60
Line and trunk pair-termination tables

NT8D37 IPE Module	
Line Cards	Tables 123 through 125
Trunk Cards	NT8D14 Universal Trunk Card: Tables 126 through 128
	NT8D15 E&M Trunk Card: Tables 129 through 137

Table 61
NT8D11 CE/PE Module: NT8D15 2-wire type 1 mode pair-terminations for connectors
A, B, E, and H (7-cable)

Pair	Pins	Pair color	I/O panel connectors				Unit
			A	B	E	H	
0T/0R E/M	26/1 28/3	W-BL/BL-W W-G/G-W	slot 0	slot 1	slot 4	slot 7	0
1T/1R E/M	30/5 32/7	W-S/S-W R-O/O-R					1
2T/2R E/M	34/9 36/11	R-BR/BR-R BK-BL/BL-BK					2
3T/3R E/M	38/13 40/15	BK-G/G-BK BK-S/S-BK					3
0T/0R E/M	42/17 44/19	Y-O/O-Y Y-BR/BR-Y	spare	slot 2	slot 5	slot 8	0
1T/1R E/M	46/21 48/23	V-BL/BL-V V-G/BR-G					1

Table 62
NT8D37 IPE Module: line card pair-terminations for connectors A, E, K, and R (12-cable)

Pair	Pins	Pair color	I/O panel connectors				Unit 16/card
			A	E	K	R	
1T/1R	26/1	W-BL/BL-W	slot 0	slot 4	slot 8	slot 12	0
2T/2R	27/2	W-O/O-W					1
3T/3R	28/3	W-G/G-W					2
4T/4R	29/4	W-BR/BR-W					3
5T/5R	30/5	W-S/S-W					4
6T/6R	31/6	R-BL/BL-R					5
7T/7R	32/7	R-O/O-R					6
8T/8R	33/8	R-G/G-R					7
9T/9R	34/9	R-BR/BR-R					8
10T/10R	35/10	R-S/S-R					9
11T/11R	36/11	BK-BL/BL-BK					10
12T/12R	37/12	BK-O/O-BK					11
13T/13R	38/13	BK-G/G-BK					12
14T/14R	39/14	BK-BR/BK-BR					13
15T/15R	40/15	BK-S/S-BK					14
16T/16R	41/16	Y-BL/BL-Y					15

Table 63
NT8D37 IPE Module: line card pair-terminations for connectors B, F, L, and S (12-cable)

Pair	Pins	Pair color	I/O panel connectors				Unit 16/card
			B	F	L	S	
1T/1R	26/1	W-BL/BL-W	slot 1	slot 5	slot 9	slot 13	0
2T/2R	27/2	W-O/O-W					1
3T/3R	28/3	W-G/G-W					2
4T/4R	29/4	W-BR/BR-W					3
5T/5R	30/5	W-S/S-W					4
6T/6R	31/6	R-BL/BL-R					5
7T/7R	32/7	R-O/O-R					6
8T/8R	33/8	R-G/G-R					7
9T/9R	34/9	R-BR/BR-R					8
10T/10R	35/10	R-S/S-R					9
11T/11R	36/11	BK-BL/BL-BK					10
12T/12R	37/12	BK-O/O-BK					11
13T/13R	38/13	BK-G/G-BK					12
14T/14R	39/14	BK-BR/BK-BR					13
15T/15R	40/15	BK-S/S-BK					14
16T/16R	41/16	Y-BL/BL-Y					15
17T / 17R	42 / 17	Y-O / O-Y	slot 2	slot 6	slot 10	slot 14	0
18T / 18R	43 / 18	Y-G / G-Y					1
19T / 19R	44 / 19	Y-BR / BR-Y					2
20T / 20R	45 / 20	Y-S / S-Y					3
21T / 21R	46 / 21	V-BL / BL-V					4
22T / 22R	47 / 22	V-O / V-O					5
23T / 23R	48 / 23	V-G / G-V					6
24T / 24R	49 / 24	V-BR / BR-V					7
25T / 25R	50 / 25	V-S / S-V					Spare

Table 64
NT8D37 IPE Module: line card pair-terminations for connectors C, G, M, and T (12-cable)

Pair	Pins	Pair color	I/O panel connectors				Unit 16/card
			C	G	M	T	
1T/1R	26/1	W-BL/BL-W	slot 2	slot 6	slot 10	slot 14	8
2T/2R	27/2	W-O/O-W					9
3T/3R	28/3	W-G/G-W					10
4T/4R	29/4	W-BR/BR-W					11
5T/5R	30/5	W-S/S-W					12
6T/6R	31/6	R-BL/BL-R					13
7T/7R	32/7	R-O/O-R					14
8T/8R	33/8	R-G/G-R					15
9T / 9R	34 / 9	R-BR / BR-R	slot 3	slot 7	slot 11	slot 15	0
10T / 10R	35 / 10	R-S / S-R					1
11T / 11R	36 / 11	BK-BL / BL-BK					2
12T / 12R	37 / 12	BK-O / O-BK					3
13T / 13R	38 / 13	BK-G / G-BK					4
14T / 14R	39 / 14	BK-BR / BK-BR					5
15T / 15R	40 / 15	BK-S / S-BK					6
16T / 16R	41 / 16	Y-BL / BL-Y					7
17T / 17R	42 / 17	Y-O / O-Y					8
18T / 18R	43 / 18	Y-G / G-Y					9
19T / 19R	44 / 19	Y-BR / BR-Y					10
20T / 20R	45 / 20	Y-S / S-Y					11
21T / 21R	46 / 21	V-BL / BL-V					12
22T / 22R	47 / 22	V-O / V-O					13
23T / 23R	48 / 23	V-G / G-V					14
24T / 24R	49 / 24	V-BR / BR-V					15
25T / 25R	50 / 25	V-S / S-V					Spare

Table 65
NT8D37 IPE Module: NT8D14 pair-terminations for connectors A, E, K, and R (12-cable)

Lead designations			Pins	Pair color	I/O panel connectors				Unit
RAN mode	Paging mode	Other modes			A	E	K	R	
0T/0R CP/MB	0T/0R A/PG	0T/0R	26/1 27/2	W-BL/BL-W W-O/O-W	slot 0	slot 4	slot 8	slot 12	0
1T/1R CP/MB	1T/1R A/PG	1T/1R	28/3 29/4	W-G/G-W W-BR/BR-W					1
2T/2R CP/MB	2T/2R A/PG	2T/2R	30/5 31/6	W-S/S-W R-BL/BL-R					2
3T/3R CP/MB	3T/3R A/PG	3T/3R	32/7 33/8	R-O/O-R R-G/G-R					3
4T/4R CP/MB	4T/4R A/PG	4T/4R	34/9 35/10	R-BR/BR-R R-S/S-R					4
5T/5R CP/MB	5T/5R A/PG	5T/5R	36/11 37/12	BK-BL/BL-BK BK-O/O-BK					5
6T/6R CP/MB	6T/6R A/PG	6T/6R	38/13 39/14	BK-G/G-BK BK-BR/BK-BR					6
7T/7R CP/MB	7T/7R A/PG	7T/7R	40/15 41/16	BK-S/S-BK Y-BL/BL-Y					7

Note: Use LD 14 to select trunk termination impedance (600 ohm or 900 ohm). See the *Administration* (553-3001-311) for information on LD 14.

Table 66
NT8D37 IPE Module: NT8D14 pair-terminations for connectors B, F, L, and S (12-cable)

Lead designations			Pins	Pair color	I/O panel connectors				Unit
RAN mode	Paging mode	Other modes			B	F	L	S	
0T/0R CP/MB	0T/0R A/PG	0T/0R	26/1 27/2	W-BL/BL-W W-O/O-W	slot 1	slot 5	slot 9	slot 13	0
1T/1R CP/MB	1T/1R A/PG	1T/1R	28/3 29/4	W-G/G-W W-BR/BR-W					1
2T/2R CP/MB	2T/2R A/PG	2T/2R	30/5 31/6	W-S/S-W R-BL/BL-R					2
3T/3R CP/MB	3T/3R A/PG	3T/3R	32/7 33/8	R-O/O-R R-G/G-R					3
4T/4R CP/MB	4T/4R A/PG	4T/4R	34/9 35/10	R-BR/BR-R R-S/S-R					4
5T/5R CP/MB	5T/5R A/PG	5T/5R	36/11 37/12	BK-BL/BL-BK BK-O/O-BK					5
6T/6R CP/MB	6T/6R A/PG	6T/6R	38/13 39/14	BK-G/G-BK BK-BR/BK-BR					6
7T/7R CP/MB	7T/7R A/PG	7T/7R	40/15 41/16	BK-S/S-BK Y-BL/BL-Y					7
0T/0R CP/MB	0T/0R A/PG	0T/0R	42/17 43/18	Y-O/O-Y Y-G/G-Y	slot 2	slot 6	slot 10	slot 14	0
1T/1R CP/MB	1T/1R A/PG	1T/1R	44/19 45/20	Y-BR/BR-Y Y-S/S-Y					1
2T/2R CP/MB	2T/2R A/PG	2T/2R	46/21 47/22	V-BL/BL-V V-O/V-O					2
3T/3R CP/MB	3T/3R A/PG	3T/3R	48/23 49/24	V-G/G-V V-BR/BR-V					3

Note: Use LD 14 to select trunk termination impedance (600 ohm or 900 ohm). See the *Administration* (553-3001-311) for information on LD 14.

Table 67
NT8D37 IPE Module: NT8D14 pair-terminations for connectors C, G, M, and T (12-cable)

Lead designations			Pins	Pair color	I/O panel connectors				Unit
RAN mode	Paging mode	Other modes			C	G	M	T	
0T/0R CP/MB	0T/0R A/PG	0T/0R	26/1 27/2	W-BL/BL-W W-O/O-W	slot 2	slot 6	slot 10	slot 14	4
1T/1R CP/MB	1T/1R A/PG	1T/1R	28/3 29/4	W-G/G-W W-BR/BR-W					5
2T/2R CP/MB	2T/2R A/PG	2T/2R	30/5 31/6	W-S/S-W R-BL/BL-R					6
3T/3R CP/MB	3T/3R A/PG	3T/3R	32/7 33/8	R-O/O-R R-G/G-R					7
4T/4R CP/MB	4T/4R A/PG	4T/4R	34/9 35/10	R-BR/BR-R R-S/S-R	slot 3	slot 7	slot 11	slot 15	0
5T/5R CP/MB	5T/5R A/PG	5T/5R	36/11 37/12	BK-BL/BL-BK BK-O/O-BK					1
6T/6R CP/MB	6T/6R A/PG	6T/6R	38/13 39/14	BK-G/G-BK BK-BR/BK-BR					2
7T/7R CP/MB	7T/7R A/PG	7T/7R	40/15 41/16	BK-S/S-BK Y-BL/BL-Y					3
0T/0R CP/MB	0T/0R A/PG	0T/0R	42/17 43/18	Y-O/O-Y Y-G/G-Y					4
1T/1R CP/MB	1T/1R A/PG	1T/1R	44/19 45/20	Y-BR/BR-Y Y-S/S-Y					5
2T/2R CP/MB	2T/2R A/PG	2T/2R	46/21 47/22	V-BL/BL-V V-O/V-O					6
3T/3R CP/MB	3T/3R A/PG	3T/3R	48/23 49/24	V-G/G-V V-BR/BR-V	7				

Note: Use LD 14 to select trunk termination impedance (600 ohm or 900 ohm). See the *Administration* (553-3001-311) for information on LD 14.

Table 68
NT8D37 IPE Module: NT8D15 2-wire paging mode pair-terminations for connectors A, E, K, and R (12-cable)

Pair	Pins	Pair color	I/O panel connectors				Unit
			A	E	K	R	
0T/0R A/PG	26/1 29/4	W-BL/BL-W W-BR/BR-W	slot 0	slot 4	slot 8	slot 12	0
1T/1R A/PG	30/5 33/8	W-S/S-W R-G/G-R					1
2T/2R A/PG	34/9 37/12	R-BR/BR-R BK-O/O-BK					2
3T/3R A/PG	38/13 41/16	BK-G/G-BK Y-BL/BL-Y					3

Table 69
NT8D37 IPE Module: NT8D15 2-wire paging mode pair-terminations for connectors B, F, L, and S (12-cable)

Pair	Pins	Pair color	I/O panel connectors				Unit
			B	F	L	S	
0T/0R A/PG	26/1 29/4	W-BL/BL-W W-BR/BR-W	slot 1	slot 5	slot 9	slot 13	0
1T/1R A/PG	30/5 33/8	W-S/S-W R-G/G-R					1
2T/2R A/PG	34/9 37/12	R-BR/BR-R BK-O/O-BK					2
3T/3R A/PG	38/13 41/16	BK-G/G-BK Y-BL/BL-Y					3
0T/0R A/PG	42/17 45/20	Y-O/O-Y Y-S/S-Y	slot 2	slot 6	slot 10	slot 14	0
1T/1R A/PG	46/21 49/24	V-BL/BL-V V-BR/BR-V					1

Table 70
NT8D37 IPE Module: NT8D15 2-wire paging mode pair-terminations for connectors C, G, M, and T (12-cable)

Pair	Pins	Pair color	I/O panel connectors				Unit
			C	G	M	T	
2T/2R A/PG	26/1 29/4	W-BL/BL-W W-BR/BR-W	slot 2	slot 6	slot 10	slot 14	2
3T/3R A/PG	30/5 33/8	W-S/S-W R-G/G-R					3
0T/0R A/PG	34/9 37/12	R-BR/BR-R BK-O/O-BK	slot 3	slot 7	slot 11	slot 15	0
1T/1R A/PG	38/13 41/16	BK-G/G-BK Y-BL/BL-Y					1
2T/2R A/PG	42/17 45/20	Y-O/O-Y Y-S/S-Y					2
3T/3R A/PG	46/21 49/24	V-BL/BL-V V-BR/BR-V					3

Table 71
NT8D37 IPE Module: NT8D15 2-wire type 1 mode pair-terminations for connectors A, E, K, and R (12-cable)

Pair	Pins	Pair color	I/O panel connectors				Unit
			A	E	K	R	
0T/0R E/M	26/1 28/3	W-BL/BL-W W-G/G-W	slot 0	slot 4	slot 8	slot 12	0
1T/1R E/M	30/5 32/7	W-S/S-W R-O/O-R					1
2T/2R E/M	34/9 36/11	R-BR/BR-R BK-BL/BL-BK					2
3T/3R E/M	38/13 40/15	BK-G/G-BK BK-S/S-BK					3

Table 72
NT8D37 IPE Module: NT8D15 2-wire type 1 mode pair-terminations for connectors B, F, L, and S (12-cable)

Pair	Pins	Pair color	I/O panel connectors				Unit
			B	F	L	S	
0T/0R E/M	26/1 28/3	W-BL/BL-W W-G/G-W	slot 1	slot 5	slot 9	slot 13	0
1T/1R E/M	30/5 32/7	W-S/S-W R-O/O-R					1
2T/2R E/M	34/9 36/11	R-BR/BR-R BK-BL/BL-BK					2
3T/3R E/M	38/13 40/15	BK-G/G-BK BK-S/S-BK					3
0T/0R E/M	42/17 44/19	Y-O/O-Y Y-BR/BR-Y	slot 2	slot 6	slot 10	slot 14	0
1T/1R E/M	46/21 48/23	V-BL/BL-V V-G/G-V					1

Table 73
NT8D37 IPE Module: NT8D15 2-wire type 1 mode pair-terminations for connectors C, G, M, and T (12-cable)

Pair	Pins	Pair color	I/O panel connectors				Unit
			C	G	M	T	
0T/0R E/M	26/1 28/3	W-BL/BL-W W-G/G-W	slot 2	slot 6	slot 10	slot 14	2
1T/1R E/M	30/5 32/7	W-S/S-W R-O/O-R					3
2T/2R E/M	34/9 36/11	R-BR/BR-R BK-BL/BL-BK	slot 3	slot 7	slot 11	slot 15	0
3T/3R E/M	38/13 40/15	BK-G/G-BK BK-S/S-BK					1
0T/0R E/M	42/17 44/19	Y-O/O-Y Y-BR/BR-Y					2
1T/1R E/M	46/21 48/23	V-BL/BL-V V-G/BR-G					3

Table 74
NT8D37 IPE Module: NT8D15 4-wire type 1 and type 2 mode pair-terminations for connectors A, E, K, and R (12-cable)

Lead designations		Pins	Pair color	I/O panel connectors				Unit
Type 1	Type 2			A	E	K	R	
TA/TB RA/RB E/M ESC/ESCG	TA/TB RA/RB EA/EB MA/MB	26/1 27/2 28/3 29/4	W-BL/BL-W W-O/O-W W-G/G-W W-BR/BR-W	slot 0	slot 4	slot 8	slot 12	0
TA/TB RA/RB E/M ESC/ESCG	TA/TB RA/RB EA/EB MA/MB	30/5 31/6 32/7 33/8	W-S/S-W R-BL/BL-R R-O/O-R R-G/G-R					1
TA/TB RA/RB E/M ESC/ESCG	TA/TB RA/RB EA/EB MA/MB	34/9 35/10 36/11 37/12	R-BR/BR-R R-S/S-R BK-BL/BL-BK BK-O/O-BK					2
TA/TB RA/RB E/M ESC/ESCG	TA/TB RA/RB EA/EB MA/MB	38/13 39/14 40/15 41/16	BK-G/G-BK BK-BR/BR-BK BK-S/S-BK Y-BL/BL-Y					3
Note: TA/TB is the transmit pair; RA/RB is the receive pair.								

Table 75
NT8D37 IPE Module: NT8D15 4-wire type 1 and type 2 mode pair-terminations for connectors B, F, L, and S (12-cable)

Lead designations		Pins	Pair color	I/O panel connectors				Unit
Type 1	Type 2			B	F	L	S	
TA/TB RA/RB E/M ESC/ESCG	TA/TB RA/RB EA/EB MA/MB	26/1 27/2 28/3 29/4	W-BL/BL-W W-O/O-W W-G/G-W W-BR/BR-W	slot 1	slot 5	slot 9	slot 13	0
TA/TB RA/RB E/M ESC/ESCG	TA/TB RA/RB EA/EB MA/MB	30/5 31/6 32/7 33/8	W-S/S-W R-BL/BL-R R-O/O-R R-G/G-R					1
TA/TB RA/RB E/M ESC/ESCG	TA/TB RA/RB EA/EB MA/MB	34/9 35/10 36/11 37/12	R-BR/BR-R R-S/S-R BK-BL/BL-BK BK-O/O-BK					2
TA/TB RA/RB E/M ESC/ESCG	TA/TB RA/RB EA/EB MA/MB	38/13 39/14 40/15 41/16	BK-G/G-BK BK-BR/BR-BK BK-S/S-BK Y-BL/BL-Y					3
TA/TB RA/RB E/M ESC/ESCG	TA/TB RA/RB EA/EB MA/MB	42/17 43/18 44/19 45/20	Y-O/O-Y Y-G/G-Y Y-BR/BR-Y Y-S/S-Y	slot 2	slot 6	slot 10	slot 14	0
TA/TB RA/RB E/M ESC/ESCG	TA/TB RA/RB EA/EB MA/MB	46/21 47/22 48/23 49/24	V-BL/BL-V V-O/O-V V-G/G-V V-BR/BR-V					1

Note: TA/TB is the transmit pair; RA/RB is the receive pair.

Table 76
NT8D37 IPE Module: NT8D15 4-wire type 1 and type 2 mode pair-terminations for connectors C, G, M, and T (12-cable)

Lead designations		Pins	Pair color	I/O panel connectors				Unit
Type 1	Type 2			C	G	M	T	
TA/TB RA/RB E/M ESC/ESCG	TA/TB RA/RB EA/EB MA/MB	26/1 27/2 28/3 29/4	W-BL/BL-W W-O/O-W W-G/G-W W-BR/BR-W	slot 2	slot 6	slot 10	slot 14	2
TA/TB RA/RB E/M ESC/ESCG	TA/TB RA/RB EA/EB MA/MB	30/5 31/6 32/7 33/8	W-S/S-W R-BL/BL-R R-O/O-R R-G/G-R					3
TA/TB RA/RB E/M ESC/ESCG	TA/TB RA/RB EA/EB MA/MB	34/9 35/10 36/11 37/12	R-BR/BR-R R-S/S-R BK-BL/BL-BK BK-O/O-BK	slot 3	slot 7	slot 11	slot 15	0
TA/TB RA/RB E/M ESC/ESCG	TA/TB RA/RB EA/EB MA/MB	38/13 39/14 40/15 41/16	BK-G/G-BK BK-BR/BR-BK BK-S/S-BK Y-BL/BL-Y					1
TA/TB RA/RB E/M ESC/ESCG	TA/TB RA/RB EA/EB MA/MB	42/17 43/18 44/19 45/20	Y-O/O-Y Y-G/G-Y Y-BR/BR-Y Y-S/S-Y					2
TA/TB RA/RB E/M ESC/ESCG	TA/TB RA/RB EA/EB MA/MB	46/21 47/22 48/23 49/24	V-BL/BL-V V-O/O-V V-G/G-V V-BR/BR-V					3

Note: TA/TB is the transmit pair; RA/RB is the receive pair.

Backplane cable expansion

You can reconfigure NT8D37 (AA and DC vintage) IPE Modules for expanded cabling. By adding and reconfiguring cable ends in the backplane slots, 24 pairs can be connected to each backplane slot.

Note: When backplane slots are reconfigured for expanded cabling, the labeling for NT8D37 IPE Modules must be changed at the MDF to reflect the change in the backplane slots.

To cable lines and trunks with expanded backplane configurations, go to “Cabling lines and trunks” on page 185.

NT8D11 CE/PE Modules

In the NT8D11 Modules, cabling for the first four IPE slots can be expanded using one NT8D81AA Cable/Filter Assembly. Cabling for all of the IPE slots can be expanded using three NT8D81AA Cable/Filter Assemblies.

Note: The first IPE slot is already fully cabled for 24 pairs, so no change is required for that slot.

Figure 149 on page 358 shows the backplane slots in an expanded configuration.

NT8D37 IPE Modules

In the NT8D37 Modules, cabling for each segment can be expanded using one NT8D81AA Cable/Filter Assembly. Cabling for the whole backplane can be expanded using four NT8D81AA Cable/Filter Assemblies.

Note: Backplane slots 0, 4, 8, and 12 (for cables A, E, K, and R) are already fully cabled for 24 pairs, so no change is required to those slots.

NT8D37 backplane cable expansion: Segment 0

- 1 Leave cable A as is in slot position L0.
- 2 Move cable end B-3 to slot position L1-3.
- 3 Remove cable C from the backplane and connect cable ends C-1, C-2, and C-3 to slot positions L2-1, L2-2, and L2-3.
- 4 Add cable D to the I/O panel by connecting cable ends D-1, D-2, and D-3 to slot positions L3-1, L3-2, and L3-3.

Figure 149
NT8D11 backplane cable designations: expanded configuration

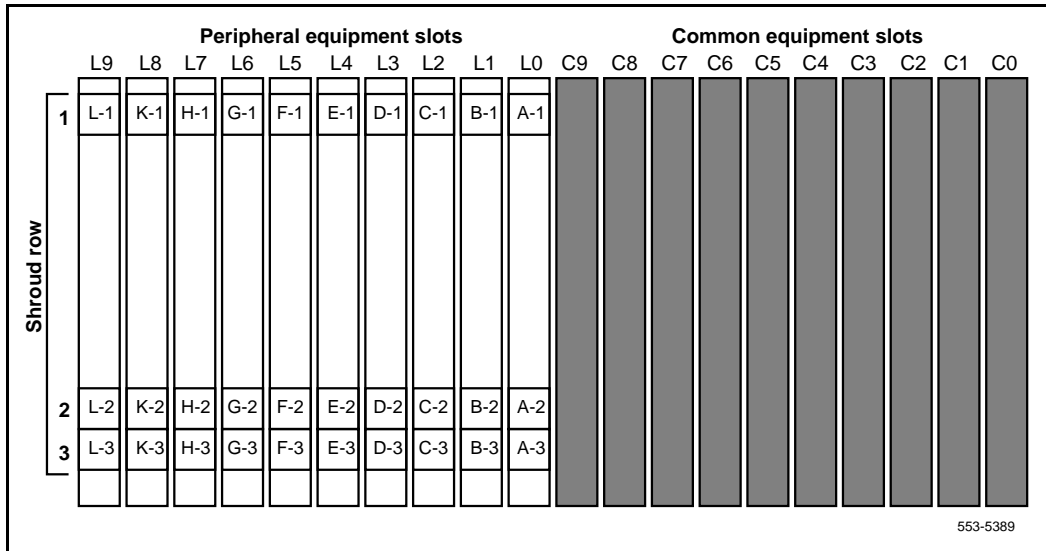

NT8D37 backplane cable expansion: Segment 1

- 1 Leave cable E as is in slot position L4.
- 2 Move cable end F-3 to slot position L5-3.
- 3 Remove cable G from the backplane and connect cable ends G-1, G-2, and G-3 to slot positions L6-1, L6-2, and L6-3.
- 4 Add cable H to the I/O panel by connecting cable ends H-1, H-2, and H-3 to slot positions L7-1, L7-2, and L7-3.

NT8D37 backplane cable expansion: Segment 2

- 1 Leave cable K as is in slot position L8.
- 2 Move cable end L-3 to slot position L9-3.
- 3 Remove cable M from the backplane and connect cable ends M-1, M-2, and M-3 to slot positions L10-1, L10-2, and L10-3.
- 4 Add cable N to the I/O panel by connecting cable ends N-1, N-2, and N-3 to slot positions L11-1, L11-2, and L11-3.

NT8D37 backplane cable expansion: Segment 3

- 1 Leave cable R as is in slot position L12.
- 2 Move cable end S-3 to slot position L13-3.
- 3 Remove cable T from the backplane and connect cable ends T-1, T-2, and T-3 to slot positions L14-1, L14-2, and L14-3.
- 4 Add cable U to the I/O panel by connecting cable ends U-1, U-2, and U-3 to slot positions L15-1, L15-2, and L15-3.

Table 77 on page 359 lists cable connections for a fully expanded configuration. Figure 150 on page 360 shows the backplane slots in a fully expanded configuration.

Table 77
NT8D37 cable connections: expanded configuration

Backplane slots-shroud rows	I/O panel/cable designation
L0-1, 2, 3	A
L1-1, 2, 3	B
L2-1, 2, 3	C
L3-1, 2, 3	D (new cable)
L4-1, 2, 3	E
L5-1, 2, 3	F
L6-1, 2, 3	G
L7-1, 2, 3	H (new cable)
L8-1, 2, 3	K
L9-1, 2, 3	L
L10-1, 2, 3	M
L11-1, 2, 3	N (new cable)
L12-1, 2, 3	R
L13-1, 2, 3	S
L14-1, 2, 3	T
L15-1, 2, 3	U (new cable)

Figure 150
NT8D37 backplane cable designations: expanded configuration

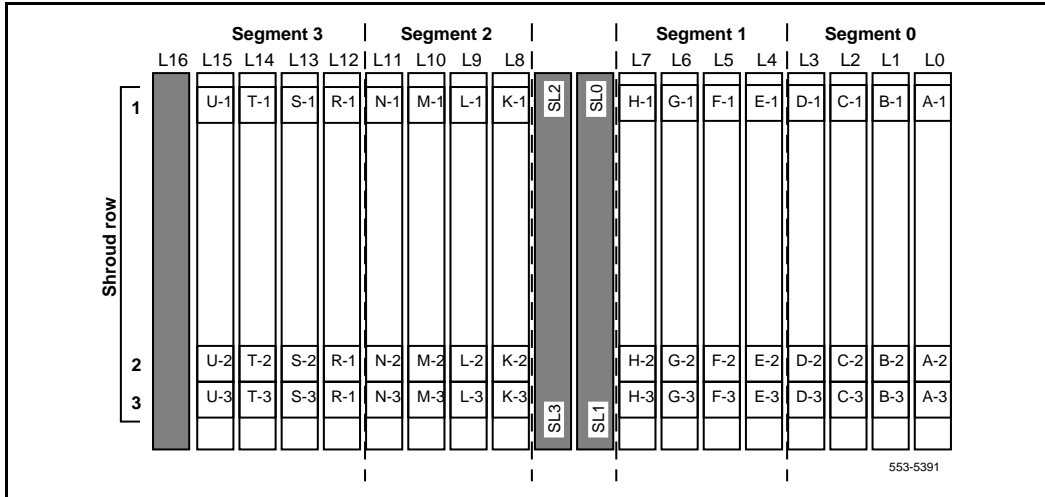

Appendix C: Customer supplied power equipment

For customers decide not to use Nortel Networks Power, Battery Back up or Distribution equipment, this appendix provides the following

- recommended grounding practices (strongly recommended)
- recommended alarm signals, which should be fed from customer power equipment to Meridian 1
- recommended power equipment features

System grounding and interconnection to Meridian 1

Figure 151 on page 362 and Figure 152 on page 364 show the recommended method of grounding customer equipment.

Figure 151
Grounding and interconnection of customer Power equipment to Meridian 1 using NT LRE

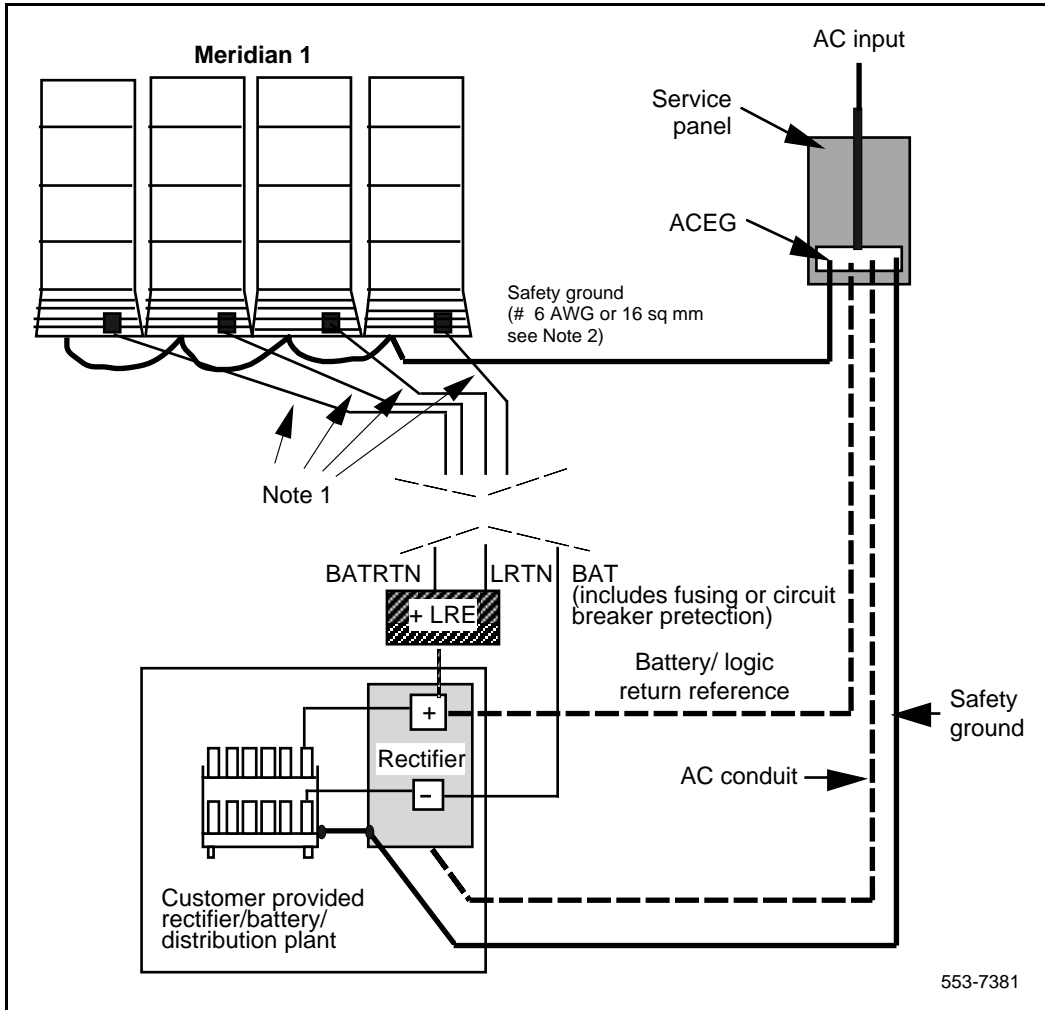

Note 1: DC power feeds to Meridian 1 pedestals. Each feed consists of two BAT (-), two BATRTN (+), and one LRTN conductors. If required the conductors can be run in conduit.

Note 2: With customer provided power equipment, the Meridian 1 frame requires a safety ground direct connection to the ACEG.

Note 3: The purpose of the LRE (logic return equalizer) is to provide a busbar where the logic return wires from different columns in a multiple column system are consolidated before connecting to the single point ground. The NT6D5303 large LRE is available from Nortel Networks for this purpose and is shown in Figure 151 on page 362.

Note 4: Customers may also provide their own LRE within the power equipment for consolidation of logic return wires. This LRE must be connected to the Positive bar in the power equipment. The combined LRE/Positive bar must be connected to the single point ground, which is usually the AC Equipment Ground (ACEG) in the AC service panel. This configuration is shown in Figure 152 on page 364.

Figure 152
Grounding and interconnection of customer Power equipment to Meridian 1 using customer LRE

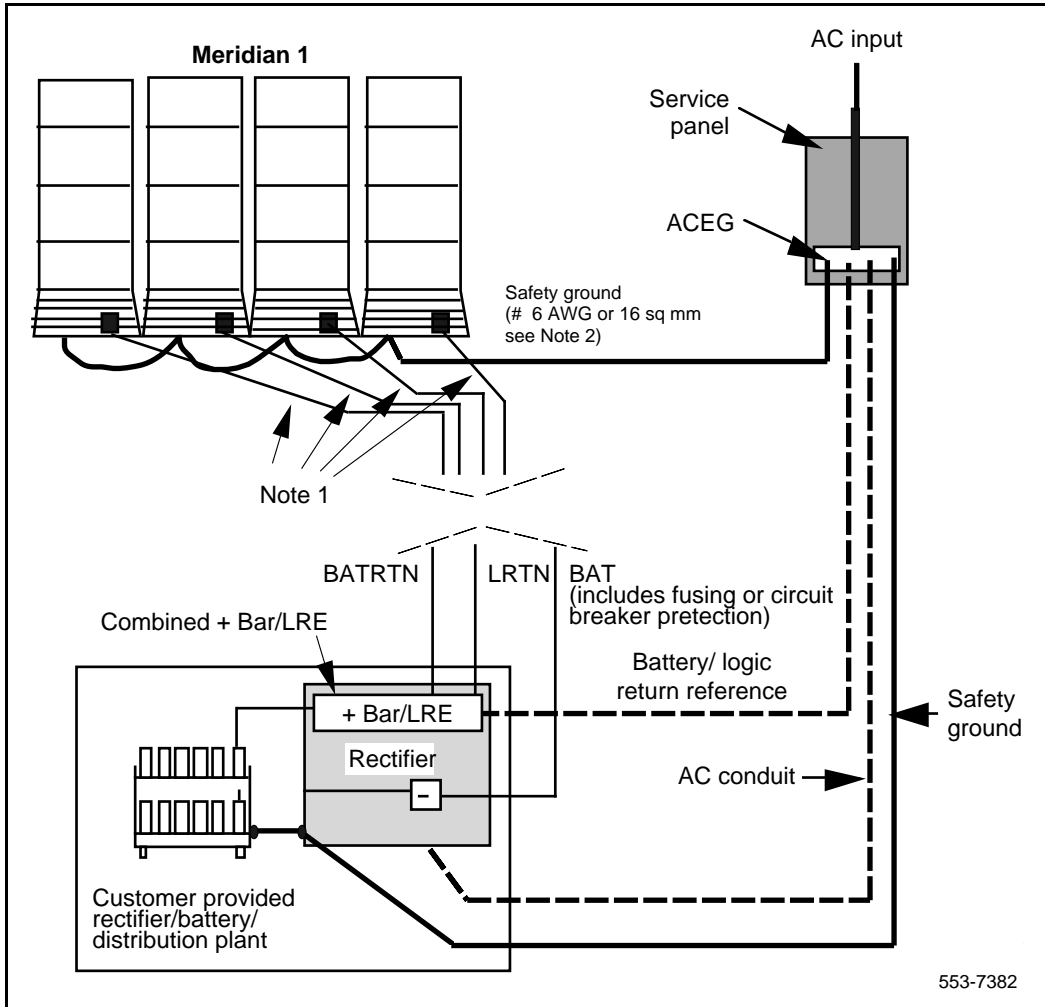

553-7382

Note 1: DC power feeds to Meridian 1 pedestals. Each feed consists of two BAT (-), two BATRTN (+), and one LRTN conductors. If required the conductors can be run in conduit.

Note 2: With customer provided power equipment, the Meridian 1 frame requires a safety ground direct connection to the ACEG.

Power feed distribution

The customer should provide adequate fusing or circuit breakers in the power equipment that supplies the Meridian 1. The fuses or circuit breakers should be rated at 30 A for every two Meridian 1 modules.

For more information about connections to Power Distribution Unit in Meridian 1 pedestal, see Appendix A.

Recommended signal connections to Meridian 1 System Monitor

Several signal connections should be supplied from the customer power equipment to connector J4 on the NT8D22 system monitor located in the Meridian pedestal. These signal are as follows:

Alarm signal

This signal is normally an open circuit. It is grounded in the case of AC input voltage failure to the power system (resulting in the power system going on battery back up). This signal will activate the Meridian 1 cabinet LED and cause a CPU alert, which will then be registered on monitoring terminals. The alarm signal is pin 5 on connector J4 on the NT8D22 system monitor.

Trip signal

If the customer supplied equipment is not configured with a Low Voltage Disconnect feature that disconnects power to the load after severe discharging of the batteries, then this Trip signal may be used to trip the Meridian 1 circuit breakers and initiate a line transfer.

Note: If the customer power system is fitted with internal Low Voltage disconnect for battery protection, then this signal should not be used.

Typically a disconnect voltage is 42 Volts DC, to provide adequate protection of batteries. When the AC input voltage returns and the batteries are sufficiently recharged, the Meridian 1 power can be restored by switching the Meridian 1 circuit breakers.

The alarm signal is pin 7 on connector J4 on the NT8D22 system monitor. This signal is normally open circuit and is grounded when the Trip signal is activated.

The NT8D46AW cable may be used for providing both Alarm and Trip signals.

For more information, see Appendix A.

Recommended features on customer supplied power equipment

Current and Voltage Meters

Customer supplied power equipment should be fitted with meters, either analog or digital, to allow monitoring of both output voltage and output current.

Visual and Audible Alarms

Customer supplied power equipment should be fitted with visual alarms for the following fault conditions:

- Distribution Fuse or Distribution Circuit breaker trip
- AC Power Fail
- Individual Rectifier fail

Audible alarms may also be provided.

Batteries

To install reserve power equipment (batteries) the installer should follow the instructions provided with the equipment. The batteries shall be connected to ground by the connection of one battery terminal (typically the positive terminal) to the Single Point Ground.

Preventative maintenance as outlined in the battery manufactures installation guide must be carried out on a regular basis and the results logged.

UPS or Auxiliary Generator

When installing UPS equipment, follow the manufacturers documentation carefully. The UPS equipment must be grounded to the ACEG or the Building Ground Reference.

List of terms

AC

Alternating current

AC equipment ground (ACEG)

An insulated conductor, used to protect personnel from injury, that does not normally carry current. The ACEG is permanently bonded to the service panel ground and to metal parts of electrical equipment that do not normally carry current.

AWG

American wire gauge

Backplane

A printed circuit board that extends across the width of the card cage and connects to the circuit card connectors

Battery backup

System power furnished by stand-by batteries that are charged by a charger. If commercial power fails, the batteries will maintain service for a limited period of time, determined by the size of the batteries and the traffic on the system. (Also called battery reserves.)

Battery return (BR, BATRTN, or RTN)

A conductor that carries -48 V dc return current. Although battery return conductors are not grounding conductors, they must be referenced to ground by a single connection.

BTU

Bus terminating unit

Bus

A copper bar, plate, or conductor

Card cage

A frame for holding circuit cards in a module; also called a card chassis

CE/PE

Common equipment/peripheral equipment

CEC

Canadian Electrical Code

Central office (CO)

The site where a telephone company terminates customer lines and houses the switching equipment that interconnects those lines

Central processing unit (CPU)

The main portion of a computer that contains the primary storage, arithmetic and logic units, and the control unit (may also mean a mainframe computer)

Circuit cards

Circuit cards carry the electronics for particular functions (such as memory and switching functions). Most cards are housed in the card cage in a module and connect to the backplane. Some cards must be installed in dedicated slots in a card cage. (Also called circuit packs or boards.)

CMA

Changeover and memory arbitrator

CMDU

Core multi-drive unit

CNI

Core to network interface

Common equipment (CE)

A hardware subsystem that houses one or more central processing units (CPUs), memory cards, disk drive units, and service cards

CSA	Canadian Standards Association
DC	Direct current
DCE	Data communications equipment
DTE	Data terminal equipment
DTR	Digitone receiver
EEPE	Enhanced existing peripheral equipment
FDI	Floppy disk interface
FDU	Floppy disk unit
FG (or FGND)	Frame ground (safety ground)
Ground	A metallic connection, whether intentional or accidental, between an electric circuit or equipment and the earth, or some conducting body that serves in place of the earth. Typically, a connection to earth obtained by a grounding electrode.
Hz	Hertz (cycles per second)
IG	Isolated ground

Input/output (I/O)

Exchange between a machine and end user equipment

IOP

Input/output processor

IPB

Inter-processor bus

IPE

Intelligent peripheral equipment

LED

Light emitting diode

Line

A communications channel or circuit; an electrical path

Logic return (LR or LRTN)

Sometimes referred to as logic ground, logic return is the voltage reference and current return path that is eventually connected to the single point ground for analog and digital circuits.

Logic return equalizer (LRE)

The point at which all logic return wires are consolidated before connecting to the single point ground. Physically, the LRE function can be provided by a separate grounding bus bar, by the common battery return bus in a DC power distribution panel, or by the AC equipment ground in an isolated ground service panel.

Loop

A bidirectional path between network equipment and peripheral equipment

MDF

Main distribution frame (cross-connect terminal)

MDU

Multi-disk unit

MFA150

150-amp modular, front access DC power system, rack style

Module power supplies

Individual power units that generate the different DC voltages required by the cards installed in each module

MPDU

Module power distribution unit

MPP600

600-amp modular DC power plant, cabinet style

MSI

Mass storage interface

NEC

National Electrical Code (U.S.A.)

Network equipment

A hardware subsystem that provides digital multiplexed switching for voice, data, and signaling paths

NT6D82

900-amp DC power system, rack style

Pedestal

The bottom element in a column. Each pedestal houses a blower or fan unit, an air filter, the PDU (which contains the column circuit breakers), and the system monitor. (The pedestal in system Option 21A houses only the PDU.)

Peripheral equipment (PE)

A hardware subsystem that provides analog and digital line and trunk interfaces and houses a combination of line, trunk, and Digitone receiver circuit cards

PFTU

Power fail transfer unit

Power distribution unit (PDU)

Input power for Meridian 1 is brought into the pedestal to the PDU. The PDU distributes input power to the column.

QBL12

75-amp external DC power distribution unit

QBL15

150-amp external DC power distribution unit

QCA13

50–200-amp rectifier/distribution unit cabinet

RPE

Remote peripheral equipment

SDI

Serial data interface

Single point ground (SPG)

A single connection used to reference electronic equipment to ground; no DC current flows through the connection unless a fault condition exists.

System monitor

A microprocessor-based circuit card that controls and monitors the status of cooling equipment and power-related hardware and functions

System SPG

The point where frame ground, logic return, AC equipment ground, and battery return are connected to ground

TDS

Tone and digit switch

TN

Terminal number

Top cap

The top cap is mounted on the top module of each column. It provides airflow exits, EMI/RFI shielding, I/O cable entry and exit, and overhead cable rack mounting. The top cap covers thermal sensor assemblies for the column.

Trunk

A single circuit between two points, both of which are switching centers or individual distribution points

Universal equipment module (UEM)

A modular, self-contained hardware cabinet that houses a card cage, power supply, backplane, circuit cards, and other basic equipment. When equipped, the UEM becomes a specific type of module, such as a CPU Module or Network Module.

UPS

Uninterruptible power supply

V ac

Voltage alternating current

V dc

Voltage direct current

Index

Numerics

500/2500-type telephones, 87

A

A connectors

- line pair-terminations, 341
- trunk pair-terminations, 343, 347, 350

A0355200 Power Fail Transfer Units, 83

A0367916 Auxiliary –48V Power Supplies, 83, 86

A0377992 Black Box ABCDE-Switches

- modem connections, 125
- system terminal connections, 114

A0377992 Black Box ABCD-Switches

- system terminal connections, 109

A0381391 UDS FastTalk modems, 117

AC (alternating current) power systems, 39

- connecting power to, 232
- installation, 43
- safety ground/protective earth and logic return wiring, 40
- UPS ground cabling, 45

acceptance tests

- blower units, 239
- module power supplies, 237
- PFTU, 243
- sysload, 240
- system terminal and system monitor, 242
- thermal sensors, 239

ACD (Automatic Call Distribution) ports, 105

ACEG (AC equipment ground), 40, 53, 301

alarm and monitoring features

- for power units, 52

alarms

- PFTU connections, 84
- system monitor cabling, 97, 321
- visual and audible alarms, 362

anchor bolts

- floor drilling for, 249

anchor kit selection, 246, 248

anchor plate installation, 250

antistatic bags, 14

automatic ground start, 87

auxiliary –48V power supplies, 83, 86

B

B connectors

- line pair-terminations, 341
- trunk pair-terminations, 347, 349, 351

backplanes

- cable expansion, 76, 353
- cabling, 335
- connectors, 195
- I/O panel connections, 196, 198, 338
- IPE module cabling, 353
- jumpers, 26, 27
- line and trunk connections, 339
- superloop cabling, 185

batteries, 283, 294, 295, 362

baud rates

- system monitor, 89

Bell 103/212 modems, 103

BELLCORE specification, 246

BIX

- designation labels, 70
- installation and designation, 71
- references, 69

Black Box ABCDE-Switches

- modem connections, 125
- system terminal connections, 109, 114

blower units

- acceptance tests, 239
- in power-up, 233, 234
- PDU installation, 313
- removing, 61

bracing rods, 252, 256

BSD messages in acceptance tests

- blower tests, 239
- module power supply, 238

BTU (bus terminating unit), 25

bypass switches

- UPS, 45

C

C connectors

- line pair-terminations, 342
- trunk pair-terminations, 346, 348, 352

cable tray kits, 37

Cable/Filter Assemblies, 353

cables and cabling

- backplane, 335
- fourth modules, 32
- I/O panels, 338
- lines and trunks, 195
- module additions, 265, 266, 268, 277
- network cards, 189
- network loops, 179
- PDU, 59, 312
- PFTU, 86
- power distribution boxes, 283, 285, 294
- routing guidelines, 15, 17
- superloops, 180
- system monitors, 94, 320
- system terminals, 103, 104

CALIFORNIA OSHPD specification, 246

call back modems, 117

captive screws, 24

card allocations

- Krone cross connect system, 76

card option settings, 25

casters, 33

CC (clock controller) cards

- superloop cabling, 180, 183, 185

CDR (Call Detail Recording) ports, 105

CE/PE (common equipment/peripheral equipment

- line pair-termination tables, 200

CE/PE (common equipment/peripheral equipment)

- backplane cabling, 335, 353
- backplane slots, 76
- BIX labels, 74
- BIX layout, 73
- trunk pair-termination tables, 200

circuit breakers

- DC power, 56, 58
- in power-up, 232, 233, 234
- module additions, 263, 265, 267, 272, 279
- PDU, 308
- power distribution box installation, 296

circuit cards, 14

CMDU (core multi-drive unit), 243

column positioning with spacers, 36

columns, 12

- adding modules to, 261
- fourth modules on, 29, 30
- module additions, 271

configuring

- system monitors, 89

Configuring the Motorola 28.8 Data/Fax Modem, 118

connecting power

- UK, 331

connectors, 195

control and distribution panels, 51

core/network modules

- jumpers, 26, 27

covers, module, 24

CP (call processing) cards

- sysloads, 240
- system terminal connections, 102, 109

-
- CPIO ports
 - modem connections, 116, 123, 124, 126, 127
 - system terminal connections, 109, 110, 112, 114
 - cross-connecting wire, 200, 339
 - current and voltage meters, 362
 - D**
 - DC (direct current) power systems, 49
 - connecting power, 234
 - external, 50
 - installing, 60, 301
 - PDU connections, 56
 - preparation, 61
 - references, 12
 - safety ground/protective earth and logic return wiring, 53, 60
 - DCE (data communication equipment), 109
 - DCON connections, 284, 286
 - designation labels, BIX, 70, 72
 - dispatch modems, 117
 - distribution boxes
 - installing, 282, 287, 294
 - rectifier adjustments, 292
 - rectifier connections, 297
 - rectifier mounting, 289
 - second, adding, 296
 - DLB (dual loop peripheral buffer) cards
 - network card cabling, 189, 193
 - DTE (data terminal equipment), 109
 - E**
 - E connectors
 - line pair-terminations, 341
 - trunk pair-terminations, 343, 347, 350
 - E&M trunk cards
 - BIX labels, 75
 - pair-terminations, 203, 347
 - earthquake bracing, 245
 - anchor plate installation, 250
 - floor drilling, 249
 - kit selection, 246
 - positioning and leveling, 254
 - rod installation, 252, 256
 - EMI shielding, 16
 - module additions, 264
 - network cards, 189
 - superloop cards, 180
 - equipment handling precautions, 13
 - equipment room floor plans, 23
 - external alarm cabling, 97
 - external DC power equipment, 50
 - F**
 - F connectors
 - line pair-terminations, 341
 - trunk pair-terminations, 345, 347, 349, 351
 - field wiring kits and terminals
 - PDU connections, 58, 310, 324
 - power distribution box installation, 297, 300
 - float voltage setting, rectifiers, 292, 298
 - floor drilling for anchor bolts, 249
 - floor plans, 23
 - four-port SDI card cabling, 108
 - fourth modules, 29, 30
 - G**
 - G connectors
 - line pair-terminations, 342
 - trunk pair-terminations, 346, 348, 352
 - gaskets
 - bracing rod installation, 254
 - spacer kits, 34
 - GFCI (ground fault circuit interrupt) devices, 39
 - global PDU, 49
 - grills, 24, 25
 - ground start feature, 87
-

ground/protective earth
AC power, 40, 43
DC power, 53, 60, 301
installing, 307
UPS, 45

H

Hayes-compatible modems, 103
high voltage shutdown setting, 292

I

IG (isolated ground) bus, 40, 53, 301
IG-L6-30 receptacles, 39
installing
QUA6 PFTU (UK), 88
insulated ground wire, 60
I/O panels
backplane connections, 196, 198
connections, 338
IPE module connections, 199, 336, 337, 353
network card cabling, 191, 193
superloop cabling, 185, 186, 187
system terminal connections, 101
IOP cards
sysload acceptance tests, 241
IPE modules
backplane cabling, 335, 337, 353
backplane slots, 76
BIX labels, 74
BIX layout, 73
cable connections, 196, 199
line pair-termination tables, 200, 341
superloop cabling, 180, 183
trunk pair-termination tables, 200, 202
trunk pair-terminations, 343

J

jumpers, 26, 27
junction boxes
modular power systems, 52
PDU, 313, 324

K

K connectors
line pair-terminations, 341
trunk pair-terminations, 343, 347, 350
Krone cross connect system (UK), 76

L

L connectors
line pair-terminations, 341
trunk pair-terminations, 345, 347, 349, 351
L6-20 receptacles, 39
L6-30 receptacles, 39
labels
Krone cross connect system, 76
ladder racks, 37
LD 17 program
SDI ports, 105
LD 37 program
module additions, 262, 265, 267, 271, 279
printer ports, 105
system terminal tests, 242
LD 42 program, 105
LD 48 program, 105
LD 135 program
disk drive unit tests, 244
LD 137 program, 243
LED (light-emitting diodes)
blower unit acceptance tests, 239
power supply acceptance tests, 238
power-up, 233, 235
rectifier settings, 292
ringing generators, 233
sysload acceptance tests, 240
leveling
earthquake bracing, 254
equipment, 33
line transfer switches, 243
lines
cabling, 195
connecting, 200, 339
pair-termination tables, 200, 339, 341
terminal numbers, 200, 339
locking latches, 24

logic return wiring
 AC power, 40, 43
 DC power, 53, 301
 LRE (logic return equalizers), 40, 45, 53, 302

M

M connectors
 line pair-terminations, 342
 trunk pair-terminations, 346, 348, 352
 master switch settings, system monitor, 90
 MDF (modular distribution frames), 69
 backplane cable expansion, 76
 BIX installation and designation, 71
 I/O panel connections, 198
 PFTU cross-connections, 86
 PFTU terminations, 84
 system monitor cabling, 97
 Meridian 1
 system grounding and interconnection, 357
 meters
 current and voltage, 362
 MFA150 Modular Power Systems, 49, 50, 51
 ground and logic return wiring, 53
 PDU connections, 325, 327
 modems, 101
 cabling, 103, 104
 connections, 103, 116, 123, 124, 126, 127
 system options 61C and 81, 109, 116
 UDS FastTalk modems, 117
 modular power systems, 49, 51
 ground and logic return wiring, 53, 55
 PDU connections, 65, 325, 327
 references, 12
 modules
 adding between modules, 267
 adding to column top, 271
 adding to columns, 261
 covers, 24
 in columns, 12
 power supplies, 238
 mounting bolts
 fourth modules, 29, 31
 module additions, 264, 268, 269, 276

MPP600 Modular Power Systems, 49, 51
 ground and logic return wiring, 55
 PDU connections, 65
 references, 12
 multiple column systems
 ground and logic return distribution, 41
 multiple-column systems
 bracing rod installation, 254
 ground and logic return distribution, 42, 44, 60, 307
 LRE, 54
 spacer kits, 13, 34
 system monitor cabling, 96
 system monitor option switches, 90
 multiple-row systems
 network card cabling, 191
 superloop cabling, 183

N

NE-A25B cable
 I/O panel connections, 198
 PFTU connections, 86
 network cards
 cabling, 189
 network loops, 179
 NT0R71 Rectifiers, 51
 NT0R72 Switched Mode Rectifiers
 connecting, 297, 299
 measuring and adjusting, 292
 power distribution boxes, 287, 288, 289
 NT5C03 Rectifiers, 301
 NT5C90 power plants, 51
 NT6C14GB Control and Distribution Panels, 51
 NT6C40DC Seismic Racks, 51
 NT6D504 LRE, 40
 NT6D52 Switched Mode Rectifiers
 modular power systems, 51
 power distribution boxes, 287
 NT6D53 Junction Boxes, 52
 NT6D5303 LRE, 302
 NT6D54 field wiring kits, 297, 300
 NT6D60 Core Modules
 jumpers, 26

- NT6D63 IOP Cards
 - sysload acceptance tests, 241
- NT6D66 Call Processing Cards
 - sysloads, 240
 - system terminal connections, 102, 109
- NT6D82 Power Systems
 - ground and logic return wiring, 303
 - installing, 282
 - PDU installation, 314, 316, 325, 328
 - references, 12
 - system monitor connections, 320
- NT7D09 Pedestals, 56, 308
- NT7D0902 Rear Mount Conduit Kit, 59, 312
- NT7D09CA Pedestals, module additions, 263
- NT7D1201 Rectifier Baffle assemblies, 289, 290
- NT7D1204 Mounting hardware kits, 289
- NT7D67CB PDU
 - circuit protection, 309
 - connecting, 311
 - equipment layout, 58
 - ground and logic return wiring, 308
 - junction boxes for, 52, 313
 - power to, 62, 313
 - preparation, 61, 313
 - safety ground, 59
- NT8D01 Controller Cards cabling, 180, 183
- NT8D04 Superloop Network Cards
 - cabling, 180, 186, 187
 - loop configurations, 188
 - multiple-row connections, 183
 - single-row connections, 180
- NT8D11 CE/PE Modules
 - backplane cabling, 335, 353
 - BIX labels, 74
 - BIX layout, 73
 - line pair-termination tables, 200, 339
 - trunk pair-termination tables, 200, 339
- NT8D1107 Superloop Adapter Plates, 183
- NT8D11AC CE/PE Modules, 76
- NT8D11BC CE/PE Modules
 - backplane slots, 76
- NT8D11DC CE/PE Modules, 76
- NT8D11EC CE/PE Modules
 - backplane slots, 76
- NT8D13 PE Modules
 - BIX layout, 73
 - line pair-termination tables, 200
 - network card cabling, 191
 - trunk pair-termination tables, 200
- NT8D14 Universal Trunk Cards
 - BIX labels, 74
 - pair-terminations, 202, 343
- NT8D15 E&M Trunk Cards
 - BIX labels, 75
 - pair-terminations, 203, 347
- NT8D22 System Monitors
 - cabling, 94
 - configuring, 89
 - installing, 319
 - module additions, 262, 267, 271
 - PDU connections, 326
- NT8D37 IPE Modules
 - backplane cabling, 335, 336, 337, 353
 - backplane slots, 76
 - BIX labels, 74
 - BIX layout, 73
 - cable connections, 196, 199
 - line pair-termination tables, 200, 339, 341
 - superloop cabling, 180, 183
 - trunk pair-termination tables, 200, 202, 339, 343
- NT8D37AC IPE Modules, 76
- NT8D37BA IPE Modules, 196, 199
- NT8D37DC IPE Modules, 76
- NT8D37EC IPE Modules, 196, 199
- NT8D41 SDI Paddle Boards
 - cabling diagram, 107
 - ports and switches, 106
 - system monitor cabling, 94
- NT8D46 cable, 123, 125
- NT8D46AD cable, 94, 95
- NT8D46AG cable, 94
- NT8D46AJ cable, 98
- NT8D46AL cable, 96
- NT8D46AP cable, 96

NT8D46AQ cable, 98
NT8D46AS cable, 95
NT8D46AT cable
 power distribution box connections, 298
 system monitor connections, 322
NT8D46AU cable, 98
NT8D46AV cable, 99, 100, 319, 322
NT8D46AW cable, 321
NT8D46BH cable, 97
NT8D46BV cable, 99, 319
NT8D46CV cable, 99, 319
NT8D46DH cable, 97
NT8D46EH cable, 97
NT8D49 Spacer Kits, 34
NT8D49AA Spacer Kits, 254, 257
NT8D52 Blower Units, 239
NT8D63 Overhead Cable Tray Kits, 37
NT8D64BD seismic bracing kits, 247
NT8D64BE seismic anchor kits, 248
NT8D64CA seismic bracing kits, 247
NT8D64CB seismic bracing kits, 247
NT8D64CC seismic bracing kits, 247
NT8D64CD seismic bracing kits, 247
NT8D64CE seismic bracing kits, 248
NT8D73 cable, 193
NT8D81AA Cable/Filter Assemblies, 353
NT8D84 cable, 125
NT8D85 cable
 network card cabling, 189
NT8D86AD cable, 191, 193
NT8D88AD cable, 185
NT8D91 cable, 181
NT8D92 cable, 185
NT8D95 cable
 modem cabling, 123, 125
 system terminal cabling, 110, 112, 114
NT8D95AJ cable, 103, 104
NT8D98 cable, 185
NT9D11 Core/Network Modules
 jumpers, 26, 27
NT9D19 Call Processing Card, 102, 109

O

option 21, 89, 94
 power distribution boxes, 287
option 21A, 39, 89
option 21E, 89, 94
 power distribution boxes, 287
option 51, 89, 94
 power distribution boxes, 287
option 51C, 13
option 61, 25, 94
 power distribution boxes, 282
 power systems, 282, 301
 system terminals, 102
option 61C, 13, 25, 89, 94
 jumpers, 26
 modems, 116
 power distribution boxes, 282, 287
 power systems, 282, 301
 sysload test, 240
 system terminals, 109
option 71, 25, 89, 94
 power distribution boxes, 282
 power systems, 282, 301
 system terminals, 102
option 81, 13, 25, 89, 94
 modems, 116
 power distribution boxes, 282
 power systems, 282, 301
 system terminals, 102, 109
option switches, 25
 system monitor, 89
Overhead Cable Tray Kits, 37
OVL messages, 242

P

P069985 Top Cap Cable Egress Panel, 37
paddle boards
 cabling diagram, 107
 ports and switches, 106
 system monitor cabling, 94
pair-termination tables, 200
 lines, 341
 trunks, 343

- PDU (power distribution unit), 49
 - connections, 56, 309, 323
 - equipment layout, 58
 - ground and logic return wiring, 308
 - junction boxes for, 52
 - modular power system, 51
 - power to, 62, 313, 324
 - preparation, 61, 313
 - safety ground, 59
 - system monitor cabling, 94, 311, 326
 - wire gauge requirements, 310
- PE (peripheral equipment)
 - trunk pair-termination tables, 200
- PE (peripheral equipment) modules
 - BIX layout, 73
 - line pair-termination tables, 200
 - network card cabling, 191
- pedestals, 12
 - grills, 24, 25
 - module additions, 263
 - power, 56, 308
- PFTU (power fail transfer unit), 83
 - acceptance tests, 243
 - alarm connections, 84
 - installation, 86
 - system monitor cabling, 97
 - trunk and telephone connections, 87
- ping-pong effect, 103
- positioning
 - BTU, 25
 - earthquake bracing, 254
 - equipment, 33
- positioning guides
 - fourth modules, 29, 30
 - module additions, 268, 270, 275, 276
- power cables
 - fourth modules, 32
 - module additions, 265, 266, 268, 277
- power cords, 43

- power distribution boxes
 - installing, 282, 287, 294
 - rectifier adjustments, 292
 - rectifier connections, 297
 - rectifier mounting, 289
 - second, adding, 296
- power systems, 12, 14, 49
 - installing, 282
 - PDU connections, 325
- power-up
 - connecting power, 232
 - preparations, 231
- precautions, 13
- printers
 - port software enable, 105
 - SDI port connections, 103
- PWR messages in acceptance tests
 - blower tests, 239
 - module power supply, 238

Q

- QBL12 Power Systems
 - ground and logic return wiring, 304
 - installing, 282
 - PDU installation, 314, 317, 325, 329
 - system monitor connections, 321
- QBL15 Power Systems
 - ground and logic return wiring, 305
 - in modular power system, 51
 - installing, 287, 294
 - PDU installation, 314, 318, 325, 330
 - rectifier adjustments, 292
 - rectifier connections, 297
 - rectifier mounting, 289
 - second, adding, 296
 - system monitor connections, 322
- QCA13 Power Systems
 - ground and logic return wiring, 306
 - installing, 301
 - PDU connections, 314, 317, 329
 - PDU installation, 325
 - references, 12
 - system monitor connections, 322

QCBIX1A connectors, 71, 72
QMBIX10A mounts, 71, 72
QMBIX12E mounts, 71
QPC414 Network Card
 connected to and NT5K11 EEPE module, 193
QPC414 Network Cards
 cabling, 189
 multiple-row connections, 191
 single-row connections, 189
QPC659 Dual Loop Peripheral Buffer Cards
 network card cabling, 189
QPC841 Four-Port SDI Card cabling diagram, 108
QSBIX20A designation strips, 71, 72

R

R connectors
 line pair-terminations, 341
 trunk pair-termination, 343
 trunk pair-terminations, 347, 350
ramps, 13
rear mount conduit kits, 59, 312
receptacles, 39
rectifiers
 baffle assemblies, 289, 290
 connecting, 297, 299
 DC power plant installation, 301
 in power-up, 234
 measuring and adjusting, 292, 298
 with power distribution boxes, 287, 289
references, 11
ringing generators
 acceptance tests, 238
 in power-up, 233
rod installation
 earthquake bracing, 252, 256
RS-232 cable
 modem cabling, 123, 124

S

S connectors
 line pair-terminations, 341
 trunk pair-terminations, 345, 347, 349, 351

safety ground/protective earth
 AC power, 40, 43
 DC power, 53, 60, 301
 installing, 307
SDI (serial data interface) ports
 cabling diagram, 108
 modem connections, 116, 123, 124, 126, 127
 software enable, 105
 system monitor interface, 89, 94
 system terminal connections, 101, 104, 105
seismic anchor kits, 246, 248
seismic bracing kits, 246
seismic racks, 51
SENSE connections, 284, 286
shipping screws, PDU installation, 313
signal connections to Meridian 1 System Monitor,
 361
single-column systems
 bracing rod installation, 254
 ground and logic return distribution, 41, 44, 60,
 307
 system monitor option switches, 89
single-row systems
 network card cabling, 189
 superloop cabling, 180, 182
slave switch settings
 system monitor, 91
smart modems, 103
spacer positioning, 35
spacers and spacer kits, 13
 bracing rod installation, 254, 257
 multiple-column systems, 34
SPG (single-point ground), 40, 53, 301
split mode monitoring, 101, 110
static discharge, 14
superloop adapter plates, 183
superloop cabling, 180
switch boxes
 modem connections, 124, 126, 127
 system terminal connections, 112, 114

- switched mode rectifiers
 - connecting, 297, 299
 - measuring and adjusting, 292
 - power distribution boxes, 287
 - with power distribution boxes, 289
- sysloads
 - acceptance tests, 240
- System 600/48 Power Plant, 49, 51
 - ground and logic return wiring, 53
 - PDU connections, 62
 - reference, 12
- system grounding and interconnection
 - Meridian 1, 357
- system installation procedures, 20
- system monitors
 - acceptance tests, 242
 - cabling, 94
 - configuring, 89
 - for DC power, 58
 - fourth modules, 32
 - installing, 319
 - module additions, 262, 265, 266, 267, 268, 271, 277
 - PDU connections, 311, 326
- system terminals, 101
 - acceptance tests, 242
 - cabling, 103, 104
 - connections, 102
 - CPIO port connections, 109, 110, 112, 114
 - system options 61C and 81, 109

T

- T connectors
 - line pair-terminations, 342
 - trunk pair-terminations, 346, 348, 352
- telephones, PFTU connections, 87
- tests
 - blower units, 239
 - module power supplies, 238
 - PFTU, 243
 - sysload, 240
 - system terminal and system monitor, 242
 - thermal sensors, 239

- thermal sensors
 - acceptance tests, 239
 - location, 12
- TN (terminal number), 200, 339
- top cap cable egress panels, 37
- top caps, 12
 - bracing rod installation, 252, 255
 - fourth modules, 29
 - grills, 37
 - module additions, 273, 274
- top of columns, adding modules to, 271
- trunks
 - BIX labels, 74, 75
 - cabling, 195
 - connecting, 200, 339
 - pair-termination tables, 200, 202, 339, 343
 - PFTU connections, 87
 - terminal numbers, 200, 339

U

- UDS FastTalk modems, 117
- universal trunk cards
 - BIX labels, 74
 - pair-terminations, 202, 343
- unloading equipment, 13
- UPS (uninterruptible power supplies)
 - ground cabling, 45
 - system monitor cabling, 98, 99
- UPS or Auxiliary Generator, 363

V

- V.42 modem standard, 116

W

- wire gauge requirements
 - DC power, 57
 - PDU, 310
- wrist straps, 14

X

- XMI messages, 238
- XON/XOFF flow control, 103

Meridian 1

System Installation Procedures

Copyright © 1990–2002 Nortel Networks
All Rights Reserved

Information is subject to change without notice. Nortel Networks reserves the right to make changes in design or components as progress in engineering and manufacturing may warrant. This equipment has been tested and found to comply with the limits for a Class A digital device pursuant to Part 15 of the FCC rules, and the radio interference regulations of Industry Canada. These limits are designed to provide reasonable protection against harmful interference when the equipment is operated in a commercial environment. This equipment generates, uses and can radiate radio frequency energy, and if not installed and used in accordance with the instruction manual, may cause harmful interference to radio communications. Operation of this equipment in a residential area is likely to cause harmful interference in which case the user will be required to correct the interference at their own expense.

SL-1 and Meridian 1 are trademarks of Nortel Networks. Intel and Pentium are trademarks of Intel Corporation. cPCI is a trademark of PCI Industrial Computer Manufacturers Group. Hilti is a trademark of the Hilti Corporation. Ramset and RedHead are trademarks of ITW Ramset/RedHead and Illinois Tool Works Inc. IBDN and BIX are trademarks of NORDX/CDT Inc.

Publication number: 553-3001-210

Document release: Standard 16.00

Date: January 2002

Printed in Canada

NORTEL
NETWORKS™