Meridian 1

Meridian 1 European Digital Telephones

Document Number: 553-3001-114

Document Release: Standard 3.00

Date: April 2000

Copyright © 1997–2000 Nortel Networks
All Rights Reserved

Printed in Canada

Information is subject to change without notice. Nortel Networks reserves the right to make changes in design or components as progress in engineering and manufacturing may warrant. This equipment has been tested and found to comply with the limits for a Class A digital device pursuant to Part 15 of the FCC rules, and the radio interference regulations of Industry Canada. These limits are designed to provide reasonable protection against harmful interference when the equipment is operated in a commercial environment. This equipment generates, uses and can radiate radio frequency energy, and if not installed and used in accordance with the instruction manual, may cause harmful interference to radio communications. Operation of this equipment in a residential area is likely to cause harmful interference in which case the user will be required to correct the interference at their own expense.

SL-1 and Meridian 1 are trademarks of Nortel Networks.

Revision history

April 2000

Standard 3.00. This is a global document and is up-issued for X11 Release 25.0x.

February 1997

Standard, release 2.00 based on changes in product.

October 1996

Standard, release 1.00 for Gate 2A.

Contents

Preface	7
Other documentation	7
Meridian digital telephones	9
Functional description	9
General features	9
Meridian digital telephones used with a headset	17
Physical characteristics	18
Software requirements	21
Terminal Options	21
External Alerter interface	22
Brandline insert	22
Key Expansion Module	22
Meridian Communications Adapter (MCA)	22
Installation	22
Configuration and Installation	22
Specifications	35
Environmental and safety considerations	35
Line engineering	36
Local alerting tones	36
Power requirements	37
Glossary	43
Index	45

Preface

This document is a global document. Contact your system supplier or your Nortel Networks representative to verify that the hardware and software described is supported in your area.

This guide provides feature, add-on module, and specification information for Meridian digital telephones.

Other documentation

For more information, refer to the following documentation:

- *Digital Telephone Line Engineering* (553-2201-180)
- *Meridian Communications Unit and Meridian Communications Adapter: Description, Installation, Administration, Operation* (553-2731-109)
- *Spares Planning* (553-3001-153)
- *Equipment Identification* (553-3001-154)
- *Line Cards: Description* (553-3001-105)
- *Telephone and Attendant Console: Installation* (553-3001-215)
- *X11 Features and Services* (553-3001-306)
- *X11 Administration* (553-3001-311)
- *Asynchronous Data user guide*
- *Meridian Digital Telephones: M3902, M3903, M3904 Quick Reference Guide*
- *Meridian Digital Telephones: M3901, M3902, M3903, M3904 User Guide*

Meridian digital telephones

This chapter provides feature, add-on module, relocation, and specification information for Meridian digital telephones.

Functional description

Meridian digital telephones are designed to provide cost-effective integrated voice and data communication. These telephones communicate with the Meridian 1 using digital transmission over standard twisted-pair wiring. They interface with the Meridian 1 using the Integrated Services Digital Line Card (ISDL) or the eXtended Digital Line Card (XDLC).

Meridian digital telephones are connected to the system through a two-wire loop carrying two independent 64 kbs PCM channels with associated signaling channels. One of the two PCM channels is dedicated to voice while the other is dedicated to data traffic.

The telephone interfaces with the Digital Line Card (XDLC) or ISDL in the Peripheral Equipment shelf of the system. The XDLC supports 16 voice and 16 data ports. The ISDL supports eight voice and eight data ports. A TN is assigned to each port in the system software.

General features

Meridian digital telephones support many general features. The location of the buttons used to activate and interact with these features is shown in Figure 1.

Figure 1
The Location and Function of Buttons on the Meridian digital telephone

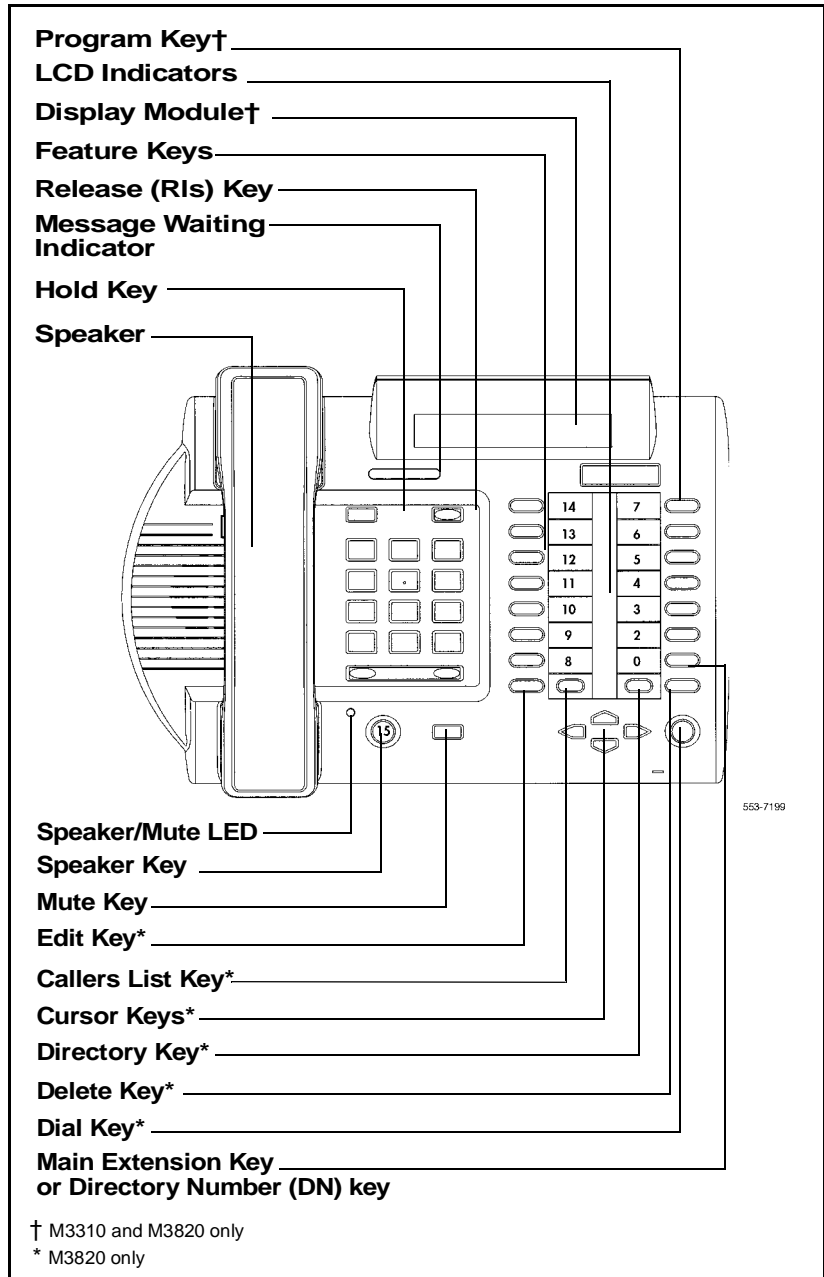

The three telephones that support the various feature levels are as follows:

M3820

Figure 2
M3820 Meridian digital telephone

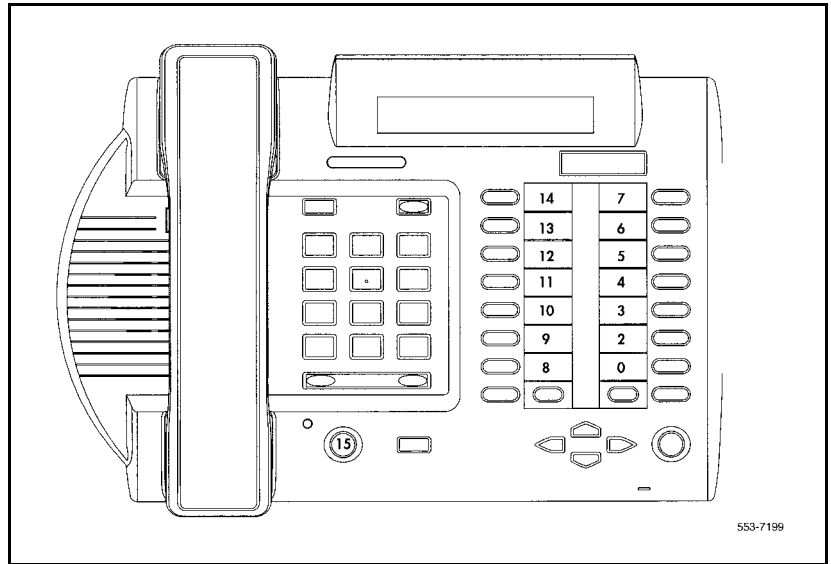

The M3820 Meridian digital telephone supports the following features:

- Handsfree, On-Hook Dialling and Group Listening
- Dedicated Release and Hold keys
- Message Waiting and Speaker/Mute Indicators
- Headset Socket
- 2 x 24 character display
- 20 Feature keys including:
 - Store/program key
 - 13 system programmable keys
 - Handsfree/speaker key
 - Mute key

- Directory key
- Caller's List key
- Edit key
- Delete key
- Volume control for:
 - Handset/Headset
 - Ringing Tone
 - Buzz Tone
 - On-Hook dialling and Group Listening
 - Handsfree
- Directory/Caller's List with 9 dedicated keys namely:
 - Directory, Callers, Edit, Delete, 4 cursor and Dial
- Support for the following terminal options:
 - MCA data option to provide integrated voice and data
 - External Alerter for high ambient noise environments
 - Wall mount ability
 - Add-on Key Expansion Modules (2 maximum)
- Brand line insert to provide for special company logos

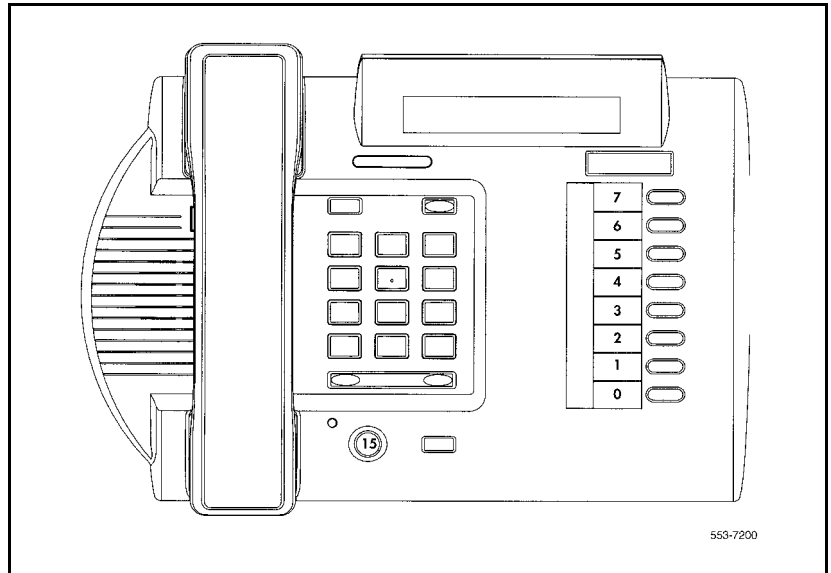
M3310**Figure 3**
M3310 Meridian digital telephone

The M3310 Meridian digital telephone supports the following features:

- Handsfree, On-Hook Dialling and Group Listening
- Dedicated Release and Hold keys
- Message Waiting and Speaker/Mute Indicators
- Headset Socket
- 2 x 24 character display
- 10 Feature keys including:
 - Program key
 - 7 system programmable keys
 - Speaker key
 - Mute key

- Volume control for:
- Handset/Headset
- Ringing Tone
- Buzz Tone
- On-Hook dialling and Group Listening
- Handsfree
- Support for the following set options:
 - MCA data option to provide integrated voice and data
 - External Alerter for high ambient noise environments
 - Wall mount ability
- Brand line insert to provide for special company logos

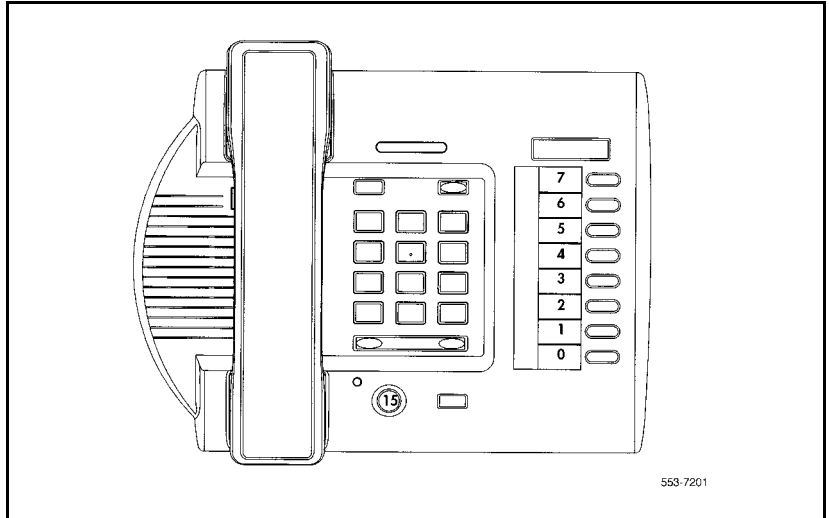
M3110**Figure 4**
M3110 Meridian digital telephone

The M3110 Meridian digital telephone supports the following features:

- On-Hook Dialling and Group Listening
- Dedicated release and hold keys
- Message Waiting and Mute Indicators
- 10 Feature System Programmable keys including:
 - 8 system programmable keys
 - Mute key
 - Speaker key
- Volume control for:
 - Handset
 - Ringing Tone
 - Buzz Tone

- On-Hook dialling and Group Listening
- Support for the following terminal options:
 - MCA data option to provide integrated voice and data
 - External Alerter for high ambient noise environments
- Wall mount ability
- Brand line insert to provide for special company logos

Meridian digital telephones used with a headset

You can use an electret headset in the headset port of the digital telephones (M3310 and M3820 only). Alternatively, choose an amplified headset that draws power from a battery or AC transformer; power is not provided by the telephone. The amplifier must draw less than 400 micro amps from the telephone jack.

The headset should be designed to work with a telephone jack with these characteristics:

Transmit interface: +5 V through 10K DC bias resistance with maximum current of 500 micro amps. The differential input impedance is 10K ohms. Connects to pins 2 and 5 of the headset jack.

Receive interface: single ended output with output impedance of 180 ohms. Connects to pins 3 and 4 of the headset jack.

Physical characteristics

Fixed keys (same for all three models)

- **Hold:** By pressing the hold key, you can put an active call on hold. Return to the caller by pressing the extension key beside the flashing LCD indicator.
- **Release (Rls):** You can terminate an active call by pressing the Rls key or by hanging up the handset. The release key is especially useful for disconnecting handsfree and headset calls.
- **Volume control:** The volume key controls the volume of the handset, the speaker and the ringer. Raise the volume by pressing the right side of the bar. Lower it by pressing the left side.
- **Mute:** When engaged in a call, you can press the mute key. The party(ies) to whom you are speaking cannot hear you. This is especially useful when on a conference call and you are only listening. When you wish to return to the two-way conversation, you must push the mute key again. The mute key applies to handsfree, handset and headset microphones.
- **Speaker/Handsfree:** The speaker key allows you to activate handsfree and group listening features. Handsfree is only available on the M3310 and M3820 models and is enabled by the system administrator. If handsfree is not configured at the switch, the telephone can only be used to listen.

The table below indicates the mode the terminal is in when the speaker key is operated under the various switch and set operations.

Table 1
Speaker Key Function

MODEL	Handsfree not selected at the switch	Handsfree selected at the switch - Group listening off	Handsfree selected at the switch - Group listening On
M3820	CPM and primary DN key-Speaker LED is not illuminated	HF and Primary DN key - speaker LED is on when in Handsfree mode	HF, Group listening and Primary DN key - speaker LED is on when in HF or Group Listening mode
M3310	CPM and Primary DN key-Speaker LED is not illuminated	HF and Primary DN key - Speaker LED is on when in HF mode	HF, Group Listening and Primary DN key - Speaker LED is on when in HF or group listening
M3110	CPM and Primary DN key- Speaker LED is not illuminated	N/A	Group listening and Primary DN key - speaker LED is on when in Group listening mode.

Note 1: CPM is Call Process Monitor which enables the user to hear, for example, the dial tone in the speaker. Group listening enables the user to speak through the handset/headset microphone and one or more parties can listen through the speaker, thus hearing both sides of the conversation. In Handsfree mode, the user (or group of users) uses both the handsfree microphone and speaker.

Note 2: Group listening is switched on or off under the program key option *1. (M3820 and M3310 only)

Additional feature keys

Message Waiting lamp key. Each telephone has a red message waiting LED just above the hold and Rls keys that lights to indicate a message is waiting. This LED is the primary message waiting indicator and lets you know that a message is waiting, regardless of whether the telephone has a message waiting key/lamp pair. You must have Message Waiting allowed Class of Service. See LD 11, *X11 Administration* (553-3001-311) and *X11 Maintenance* (553-3001-511).

If you do assign a message waiting key/lamp pair, there will be two indications of a message waiting:

- the red Message Waiting LED lights
- the LCD associated with the Message Waiting key blinks

Autodial key. You can assign an Autodial Key that dials the message center (or voice mail system) to avoid the double indication or have no key/lamp pair assigned to the message center.

Programmable Feature keys

Each Meridian digital telephone has a number of programmable keys with LCD indicators that can be assigned to any combination of directory numbers and features. The M3820 has 13 fully programmable feature keys; the M3310 has seven, and the M3110 has eight. The lower right-hand key (key 0) is reserved for the Primary DN.

LCD indicators support four key/LCD states:

Function	LCD state
idle	off
active	on (steady)
ringing	flash (60 Hz)
hold	fast flash (120 Hz)

Note: An indicator fast flashes when you have pressed a feature key but have not completed the procedure necessary to activate the feature.

Software requirements

Meridian digital telephones are supported by X11 release 16 and later software. The package number for the Meridian digital telephones is (170.) The mnemonic is ARIE. The DSET package (88) and the TSET package (89) are required.

Terminal Options

This section describes the options available for Meridian digital telephones. Table 2 lists the features and optional hardware available for each telephone.

Table 2
Hardware features and options

	M3820	M3310	M3110
Programmable Feature keys	13	7	8
Handsfree microphone	x	x	
Optional hardware available:			
Key Expansion Module	x		
Meridian Communications Adapter (MCA)	x	x	x
External alerter interface	x	x	x
Brandline insert	x	x	x
Note: In this table, x indicates available features for the telephone type listed in the top row.			

External Alerter interface

The External Alerter Board provides an interface to standard remote ringing devices, such as a ringing unit, installed in a location separate from the telephone. The External Alerter interface is not the remote ringer itself, but provides access to standard, off-the-shelf remote ringing devices. The Alerter Board requires additional power. See “Power requirements” on page 37.

You can program the External Alerter interface to activate a ringer (or light) when the telephone rings or when the telephone is in use (off-hook).

For information on installing and setting up the External Alerter, see “Add-on modules” in *Telephone and Attendant Console: Installation* (553-3001-215).

Brandline insert

The telephone contains a removable insert designed to accommodate custom labeling. You can order blank Brandline Inserts and have a printer silk screen your company logo on them.

Key Expansion Module

A 22-key unit module can be attached to any M3820 terminal. The extra keys can be assigned to any combination of lines and features. You can add up to two expansion modules to a terminal. You will need a separate footstand for the module(s), one for a single module, one for a double.

Meridian Communications Adapter (MCA)

The MCA lets you connect your telephone to a personal computer or terminal. You can then use your telephone to exchange data between your computer and other computers. The MCA can be used with all three models.

Installation

Configuration and Installation

Configuration

Use Overlay 11 (Meridian Digital Telephone Administration) to configure the telephones. All prompts are defaulted (or set as required) except for those noted in the tables following:

Table 3
M3110 Configuration

Prompt	Response	Comments
REQ	NEW	
TYPE	2616	M2616 set model used
DES	M3110	Enter appropriate set identifier
CLS	HFA (HFD)	Group Listening Allowed (Denied)
	NDD	No digit display
KEY 08	NUL	Keys 8-14
	09 NUL	programmed as NUL.
	10 NUL	If Group Listening is
	11 NUL	denied (CLS HFD),
	12 NUL	Key 15 is also
	13 NUL	programmed as NUL.
	14 NUL	
If Group Listening is denied (CLS HFD), Key 15 is also programmed as NUL.		

Figure 5
M3110 Key Designation

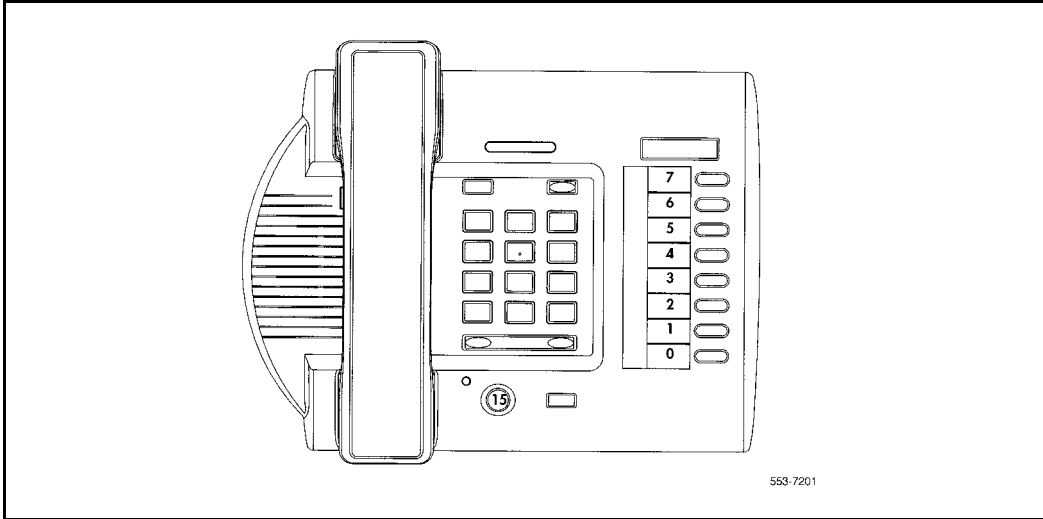

Table 4
M3310 Configuration

Prompt	Response	Comments
REQ	NEW	
TYPE	2616	M2616 set model used
DES	M3310	Enter appropriate set identifier
CLS	HFA (HFD)	Handsfree Allowed (Denied)
KEY	08 NUL 09 NUL 10 NUL 11 NUL 12 NUL 13 NUL 14 NUL	Keys 8-14 programmed as NUL. If Handsfree is denied (CLS HFD), Key 15 is also programmed as NUL.

Figure 6
M3310 Key Designations

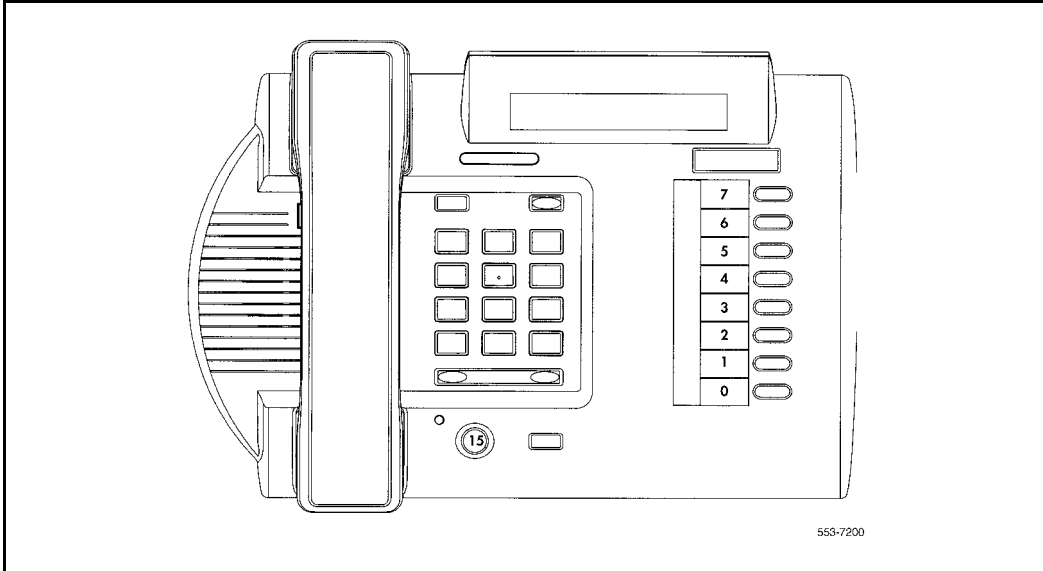

Table 5
M3820 Configuration

Prompt	Response	Comments
REQ	NEW	
TYPE	2616	M2616 set model used.
DES	M3820	Enter appropriate set identifier.
CLS	HFA (HFD)	Handsfree Allowed (Denied)
	AHA	Automatic Hold Allowed
	DNDD	Dialed Name Display Denied
	CNDA	Call Party Name Display Allowed
	CNIA	Call Number Information Allowed
KEY	LNA	Last Number Redial Allowed
	01 NUL Note: If short hunt is configured, then Key 01 must be configured as an SCR key with the same DN as key 0. For MARP to operate with short hunt configured, Key 01 must be configured as the MARP key.	Keys 01 programmed as NUL. If Handsfree is denied (CLS HFD), Key 15 is also programmed as NUL.

Figure 7
M3820 Key Designations

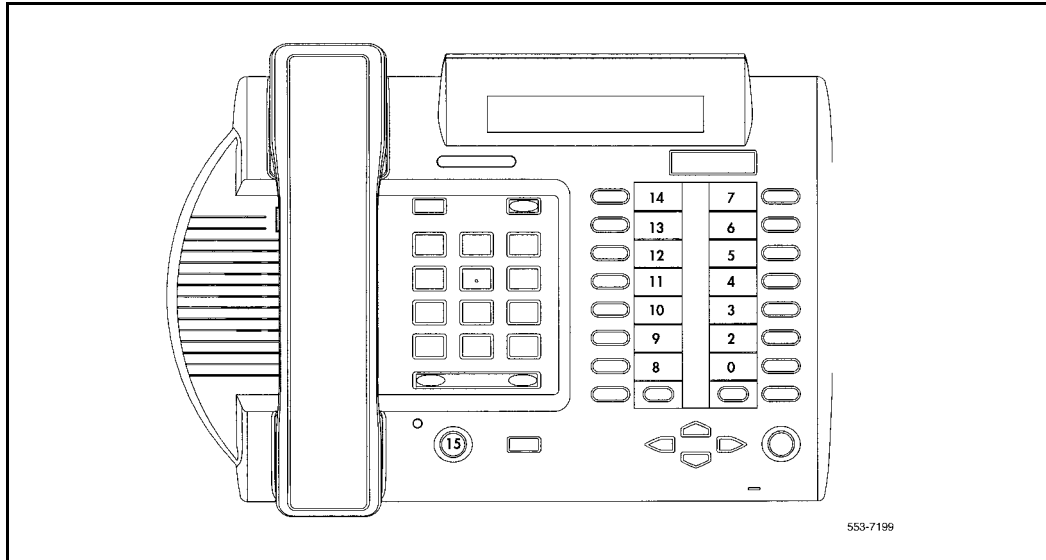

Table 6
Overlay 20 Print Routine

Prompt	Response	Comments
REQ	PRT	
TYPE	2616	M2616 set model used.
DES	M3110 M3310 M3820 M3+	Enter appropriate set identifier Or M3+ to get a list of all three set types.

Installation

The Installation procedure for Meridian digital telephones follows:

- 1** Complete the wiring and cross-connections (loop power) before connecting the telephone to the connecting block.
- 2** Place the telephone on the desk in the normal operating position.
- 3** Place the RIs and Hold key caps on their positions just above the dialpad, with the Hold key closest to the handset.
- 4** Print the directory number on the designation card. Remove the number lens from its position underneath the handset, insert the designation card and snap the lens into place.
- 5** Print the feature keys on the label strip. Remove the label lens (beside the feature keys), insert the label strip and snap the lens into place.
- 6** Plug the line cord connector into the connecting block.
- 7** Perform the self test and acceptance procedures (see procedure 16 for Meridian Modular telephones in the *Telephone and Attendant Console: Installation* (553-3001-215)).
- 8** Supply the user with a quick reference card.

Installation of Hardware Options

This section describes the procedure for installation of the following options:

- 1** Power Board on all models.
- 2** Headset on M3310 and M3820 telephones.
- 3** Wallmount/Desktop Position change.

For installation of other options (MCA data option, external alerter and key expansion modules) see the section on Add-on modules for Meridian Modular Telephones (NT2K models) in the *Telephone and Attendant Console: Installation* (553-3001-215).

Power Board Installation

To open the Telephone:

- 1 Place the telephone, upside-down, on a padded, level surface.
- 2 Using a #1 Phillips screwdriver, remove the two screws holding the footstand (if fitted).
- 3 Disconnect and remove all cords including the handset and headset if fitted, from the telephone.
- 4 Use a #1 Phillips screwdriver and remove the four screws holding the base of the telephone.

To install the Power Board:

- 1 Remove the cable from the power board including the right angle header.
- 2 Disconnect the display cable from P4 on the main PCB. Note the orientation of this connector.
- 3 Place the power board to the left of the main PCB with the widest section of the power board nearest the display. Make sure that the display cable comes over the power board.
- 4 Clip the power board in place, by inserting the right hand side of the board under the clip, then push down on the left hand side adjacent to the clips provided.
- 5 Use a #1 Phillips screwdriver and the screw supplied to fasten the power board to the front cover of the telephone.
- 6 Remove and discard the two links on J8 on the telephone's main PCB.
- 7 Connect the power board cable (B0247405) to J8.

Note the key to prevent misconnection.

- 8 Connect the cable to the header at H1 on the power board as shown in the figure below).
- 9 Reconnect the display cable to P4.

Note: Do NOT twist the cable.

To reassemble the Telephone:

- 1 Replace the base cover and make sure that the cables lie flat.
- 2 Insert the four screws to secure the base.
- 3 Assemble the MCA to the footstand using the two screws provided.
- 4 Connect the cable to the 8 way jack on the base of the telephone.
- 5 Reconnect all cords to the telephone.
- 6 Replace the footstand with the two screws (if previously fitted).
- 7 Place the power board label on the footstand for tracking purposes.

Headset Installation (M3310 and M3820 only)

Use the following procedure to add a headset to a Meridian telephone:

- 1 Unplug the line cord from the connecting block.
- 2 Remove the handset and place the telephone upside down on top of a level, solid work surface covered with soft material or paper to prevent damage to moveable keys and the telephone face.
- 3 Remove the 2 screws from the telephone footstand (if fitted) to separate the footstand from the telephone.
- 4 Plug the headset TELADAPT connector into the socket on the base of the telephone marked with a headset icon.
- 5 Route the headset cord through the channels at the side of the telephone.
- 6 Replace the footstand in the same position and tighten both screws (if previously fitted).
- 7 Place the telephone back on the desk in the normal operating position.
- 8 Plug the line cord connector back into the connecting block.

Figure 8
Power Board Installation

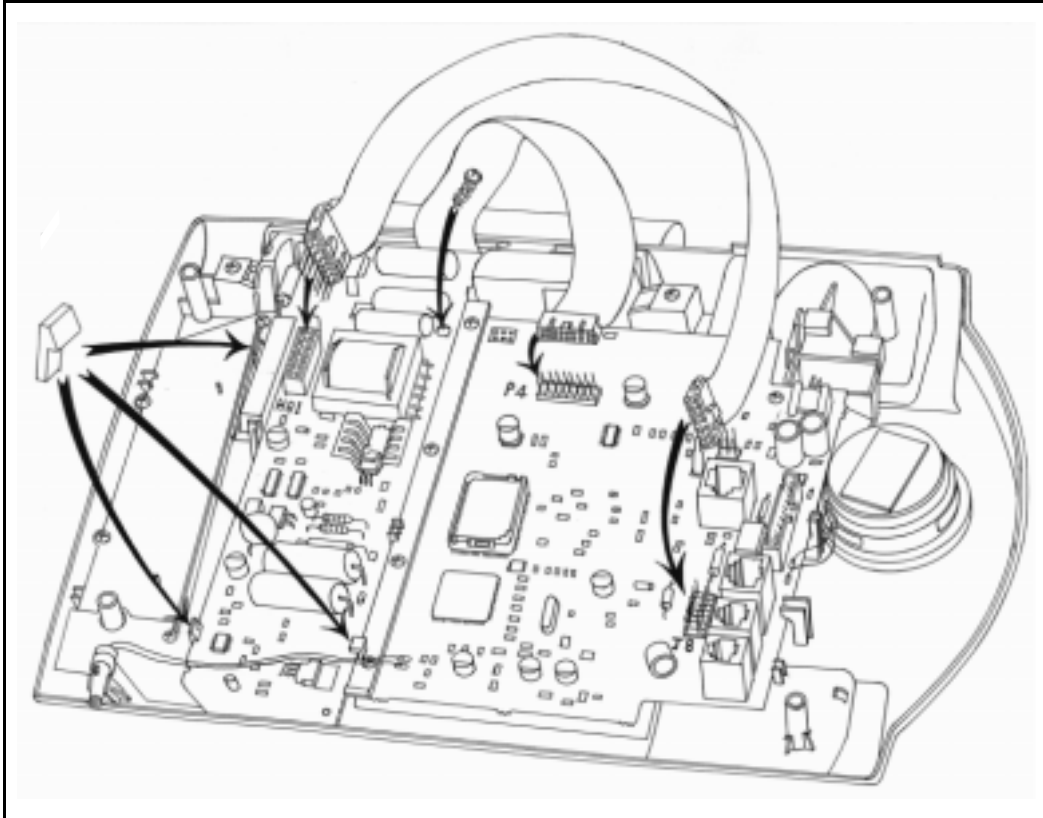

Telephone Positions

Your Meridian telephone can be installed in three different positions - two desktop positions and a wall mount position. The two desktop positions provide two different angles for the telephone on the desktop. The telephone is supplied in the steeper of the two positions. The procedure to change to the more shallow angle is as follows:

- 1** Unplug the line cord from the connecting block.
- 2** Remove the handset and place the telephone upside down on top of a level, solid work surface covered with soft material or paper to prevent damage to moveable keys and the telephone face.
- 3** Remove the 2 screws from the telephone footstand (if fitted) to separate the footstand from the telephone.
- 4** Snap the footstand back into place using the alternate slots located closer to the back of the set and tighten the screws (if previously fitted).
- 5** Place the telephone back on the desk in the normal operating position.
- 6** Plug the line cord connector back into the connecting block.

The procedure to wall mount the telephone by reversing the footstand is as follows:

Note 1: The footstand cannot be reversed when the MCA data option or key expansion module is equipped so such telephones cannot be wall mounted.

Note 2: An additional clip is provided for wall mounting the telephone. This clip is attached to the switchhook rest to prevent the handset from slipping when mounted on the wall.

- 1** Unplug the line cord from the connecting block.
- 2** Remove the handset and place the telephone upside down on top of a level, solid work surface covered with soft material or paper to prevent damage to moveable keys and the telephone face.
- 3** Remove the 2 screws from the telephone footstand (if fitted) to separate the footstand from the telephone.

- 4** Remove the wall mount clip located inside the footstand and insert the clip in the switchhook rest using the holes provided.
- 5** Rotate the footstand 180 degrees, snap the footstand back into place and tighten the screws. Note that the footstand must be screwed to the base for wall mounting.
- 6** Mount the telephone on the wall using the wall mount holes provided on the bottom of the footstand.
- 7** Plug the line cord connector back into the connecting block.

Specifications

This section lists the specifications required for Meridian digital telephones.

Environmental and safety considerations

All Meridian digital telephones are designed to comply with:

EN 60950:1992 - Safety of Information Technology Equipment including Electrical Business Equipment.

EN 41003:1993 - Particular Safety Requirements for Equipment to be connected to Telecommunication Network.

Temperature and humidity

Operating state:

Temperature range 0° to 50°C (32° to 104°F)

Relative humidity 5% to 95% (noncondensing). At temperatures above 34°C (93°F) relative humidity is limited to 53 mbar of water vapor pressure.

Storage:

Temperature range -50° to 70°C (-58° to 158°F)

Relative humidity 5% to 95% (noncondensing). At temperatures above 34°C (93°F) relative humidity is limited to 53 mbar of water vapor pressure.

Electromagnetic interference

All the digital telephones are designed to comply with:

EN 50082-1:1992 - Electromagnetic Compatibility - Generic immunity standard Part 1: Residential, commercial and light industry.

EN 50081-1:1992 - Electromagnetic Compatibility - Generic emissions standard. Generic standard class: Residential, commercial and light industry.

Line engineering

Meridian digital telephones use twisted pair wiring on transmission lines selected by the rules given in *Digital Telephone Line Engineering* (553-2201-180). The maximum permissible loop length is 3500 ft. (1067 m), assuming 24 AWG (0.5 mm) standard twisted wire with no bridge taps. A 15.5 dB loss at 256 kHz defines the loop length limit. (Longer lengths are possible, depending on the wire's gauge and insulation.) Table 7 gives detailed information on loop lengths.

Table 7
Loop lengths for Meridian digital telephones

	QPC578 A and B	QPC578 C +	NT8D02
PVC insulated cable (polyvinyl chloride)			
22 or 24 AWG	100–3000 ft. (30.5–915 m)	0–3500 ft. (0–1067 m)	0–3500 ft. (0–1067 m)
26 AWG	100–2100 ft. (30.5–640 m)	0–2600 ft. (0–945 m)	0–2600 ft. (0–793 m)
Note 1: No bridge taps or loading coils are allowed.			
Note 2: Effect of line protector at MDF reduces loop length by 500 ft.			

Note: Use only the line cord provided with the telephone. Using a cord designed for another telephone could result in damage to the cord.

Local alerting tones

Each telephone provides four alerting tones and a buzz sound. The system controls the ringing cadence by sending tone-ON and tone-OFF messages to the telephone. The alerting tone cadences cannot be changed from the telephone but can be altered for individual terminals by software controlled adjustments in the system. See *X11 Administration* (553-3001-311). All other telephone tones, such as dial tone or overflow, are provided by the Meridian 1 from a Tone and Digit Switch.

Alerting tone characteristics

The tone frequency combinations are as follows:

Tone	Frequencies	Warble Rate (Hz)
1	667 Hz, 500 Hz	5.2
2	667 Hz, 500 Hz	2.6
:		
3	1600 Hz, 2000 Hz	5.2
4	1600 Hz, 2000 Hz	2.6
:		
3	333 Hz, 250 Hz	5.2
4	333 Hz, 250 Hz	2.6

A 500 Hz buzz signal is provided for incoming call notification while the receiver is off-hook.

Power requirements

The Meridian digital telephones are loop powered. Loop power, originating in the ISDLC or the DLC, consists of a 30 V dc power source and assumes a 3500 ft. (1219 m) maximum loop length of 24 AWG (0.5 mm) wire and a minimum 15.5 V dc at the telephone terminals.

Note: The loop length limit is defined by a 15.5 dB loss at 256 KHz. Longer lengths can be determined using the wire's gauge and insulation.

Some configurations of telephones and options need more than basic loop power to operate. Table 8 lists the types of Meridian digital telephones and shows when additional power is needed to operate the telephone or its optional hardware. Power Supply Boards come installed in factory-assembled configurations that require additional power.

Note: If a power failure occurs, configurations that require loop power will continue to work only if the system has battery backup. Only those options that require additional power will cease to function.

Table 8
Power requirements, Meridian digital telephones

Telephone type	Loop power	Additional power (Power Supply Board)
M3820	Terminal, handsfree, headset, key expansion	MCA, External Alerter Interface
M3310	Terminal, headset, handsfree	MCA, External Alerter Interface
M3110	Terminal	MCA, External Alerter Interface

Power supply board

The power supply option consists of a power supply board that mounts inside the telephone, coupled with an external wall-mount transformer or closet power supply that provides power to the power supply board. The power supply board receives its power through pins 1 and 6 of the line cord.

The power supply board connects to the telephone through a 14-pin bottom entry connector.

Local plug-in transformer

A single winding transformer equipped with a 10 ft. (3 m) cord of 22 AWG two-conductor stranded and twisted wire with a modular RJ-11 duplex adapter can provide the additional power needed to operate the telephone and its options. (See Figure 9).

CAUTION

Do not plug any equipment other than the terminal into the RJ-11 transformer adapter, as damage to equipment can result.

Figure 9
Configuration of local plug-in transformer

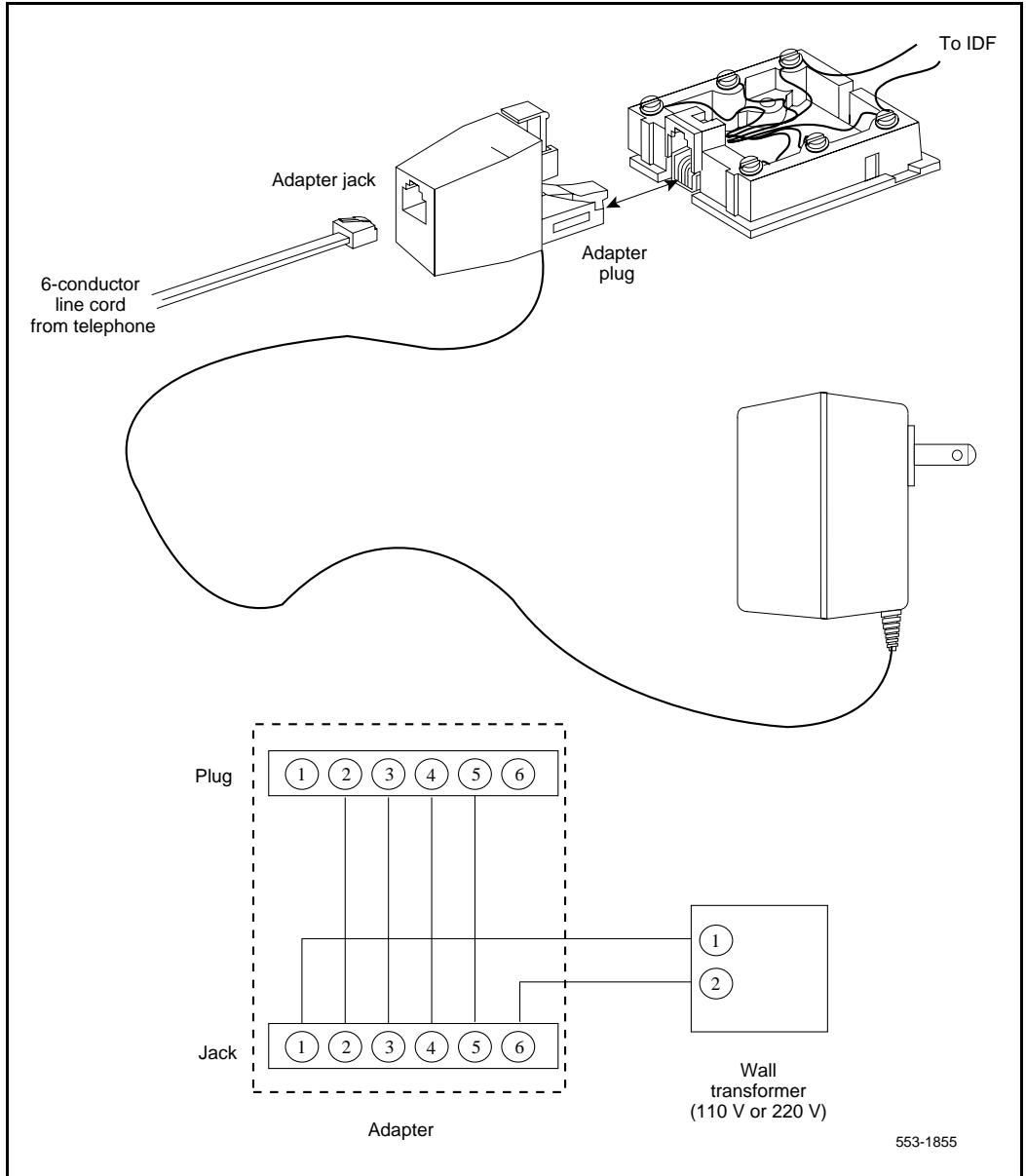

120 V transformer The following minimum specifications must be met by this transformer:

Input voltage	120 V ac/60 Hz
No load output voltage	29 V ac maximum
Voltage at rated current	26.7 V ac minimum
Rated load current	700 mA

240 V transformer The following minimum specifications have to be met by this transformer:

Input voltage	240 V ac/50 Hz
No load output voltage	29 V ac maximum
Voltage at rated current	26.7 V ac minimum
Rated load current	700 mA

Note 1: You cannot wall mount the telephone over the wall jack when using a transformer because of the size of the RJ-11 adapter. Hang it above or to the side of the jack and run the line and power cords to it.

Note 2: The above-mentioned transformers can also be used with outlets identified as 110V or 220V.

Closet Power Supply

Closet power can be obtained from an AC transformer for loops of 100 ft. (30 m) or less, or a DC transformer for loop lengths of 650 ft. (198 m) or less. An equivalent power source can be used but must be UL listed to provide isolation of outputs to the terminal. See Figure 10.

CAUTION

When using closet power, do not plug the TELADAPT connector into any equipment other than the Meridian digital telephone, as damage to equipment may result.

Note 1: All terminals must be isolated from the input winding and each terminal must be isolated from all other terminal windings. A separate winding is required for each terminal, and grounds must not be connected.

Note 2: The QUT1 closet power supply source is not compatible with Meridian digital telephones.

The AC source must be be rated at 29 V ac, 700 mA isolated. The DC source must be rated at 42 V dc, 300 mA isolated, with current limiting output of 1 amp.

Figure 10
Closet Power Supply configuration

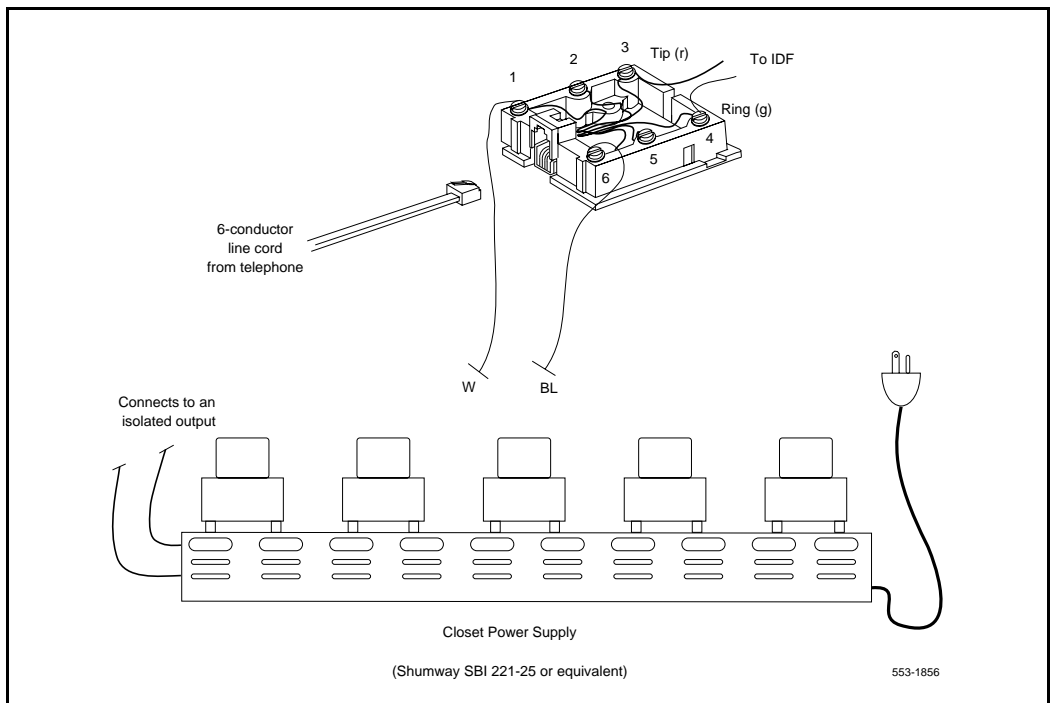

Glossary

This section lists, by alphanumeric order, the acronyms, abbreviations, and initializations used in this guide.

ACD	Automatic Call Distribution
ADO	Asynchronous Data Option
COS	Class of Service
CCOS	Controlled Class of Service
CPM	Call Progress Monitor
CPND	Calling Party Name Display
DCE	Data Communications Equipment
DLC	Digital Line Card
DN	Directory Number

DSIC

Digital Set Interface Chip

DTE

Data Terminal Equipment

EIA

Electronic Industries Association

FCC

Federal Communications Commission

IDF

Intermediate Distribution Frame

ISDL

Integrated Services Digital Line Card

LCD

Liquid Crystal Display

LED

Light Emitting Diode (lamp)

MDF

Main Distribution Frame

MCA

Meridian Communications Adapter

PCM

Pulse Code Modulation

TN

Terminal Number

Index

A

- active state
 - M3820, M3310, M3110, 20
- alerting tones
 - M3820, M3310, M3110, 36
- Asynchronous Data Option. *See* ADO (Asynchronous Data Option)

B

- batteries
 - for headsets, 17
- Brandline Inserts, 22

C

- cables. *See* wiring and loop lengths
- cards
 - DLC (Digital Line Card), 9
 - ISDLC (Integrated Services Digital Line Card), 9
- closet power supplies, 38, 40
- cords
 - and TELADAPT snap-in connectors, 40
 - See also* wiring and loop lengths
- custom labeling (logos) with Brandline Inserts, 22

D

- data calls capability
 - See also* ADO (Asynchronous Data Option)
- data channels, 9
- dialing
 - See also* Handsfree operation
- dimensions. *See under individual modes of telephones*

- DLC (Digital Line Card), 9

E

- electret headsets, 17
- electromagnetic interference specifications
 - M3820, M3310, M3110 telephones, 35
- environmental and safety considerations
 - M3820, M3310, M3110, 35
- External Alerter interface, 22

F

- frequencies. *See* local alerting tones

G

- glossary, 43

H

- Handsfree operation
 - M3820, M3310, M3110 terminals, 21
- headsets
 - electret, 17
 - interfaces, 17
- hold state
 - M3820, M3310, M3110, 20
- humidity range requirements. *See* temperature and humidity ranges for operations

I

- idle state
 - M3820, M3310, M3110 telephones, 20
- ISDLC (Integrated Services Digital Line Card), 9

J

- jacks
 - for headsets, 17
 - and TELADAPT snap-in connectors, 40

L

- LCD indicators
 - M3820, M3310, M3110, 20
 - See also* screens
- local alerting tones. *See* alerting tones
- logos with Brandline Inserts, 22
- loop lengths. *See* wiring and loop lengths

M

- M3820, M3310, M3110
 - environmental and safety considerations, 35
 - hardware features and options, 21
 - line engineering, 36
 - local alerting tones, 36
- M3820, M3310, M3110 telephones
 - power requirements
 - M3820, M3310, M3110 tele-
phones, 37
- Meridian 1 telephones
 - related documentation, 7
- Meridian digital telephone headset interface, 17
- Meridian digital telephones M3820, M3310,
M3110, 20
 - functions, connections, and interfaces, 9
- Meridna digital telephones M3820, M3310, M3110
 - fixed keys, 18
- message waiting feature, 20
- microphone
 - on M3820, M3310, M3110 telephones, 21

P

- Peripheral Equipment shelf, 9
- Phase II/III QSU1 telephones. *See* SL-1 telephones
- power requirements
 - for headsets, 17, 37

- for recording devices, 17
- See also* batteries; transformers

- programmable keys
 - M3820, M3310, M3110, 20
 - M3820, M3310, M3110 telephones, 21
 - See also* softkeys
- PVC cable, 36

R

- remote ringers, 22
- ringing state
 - on M3820, M3310, M3110, 20

S

- safety considerations. *See* environmental and safety
considerations
- softkeys
 - See also* programmable keys

T

- TELADAPT snap-in connectors, 40
- telephones. *See* Meridian 1 telephones
- temperature and humidity ranges for operations
 - Meridian digital telephones, 35
- tones. *See* alerting tones; volume control
- transformers
 - for headsets (AC), 17
 - local plug-in, 38
 - See also* power requirements

V

- voice channels/ports, 9
- volume control
 - M3820, M3310, M3110, 20

W

- warble rates. *See* local alerting tones
- wiring and loop lengths
 - M3820, M3310, M3110, 40
 - M3820, M3310, M3110 telephones, 36, 37

Meridian 1

Meridian 1 European Digital Telephones

Copyright © 1997–2000 Nortel Networks

All Rights Reserved

Information is subject to change without notice. Nortel Networks reserves the right to make changes in design or components as progress in engineering and manufacturing may warrant. This equipment has been tested and found to comply with the limits for a Class A digital device pursuant to Part 15 of the FCC rules, and the radio interference regulations of Industry Canada. These limits are designed to provide reasonable protection against harmful interference when the equipment is operated in a commercial environment. This equipment generates, uses and can radiate radio frequency energy, and if not installed and used in accordance with the instruction manual, may cause harmful interference to radio communications. Operation of this equipment in a residential area is likely to cause harmful interference in which case the user will be required to correct the interference at their own expense.

SL-1 and Meridian 1 are trademarks of Nortel Networks.

Publication number: 553-3001-114

Document release: Standard 3.00

Date: April 2000

Printed in Canada

NORTEL
NETWORKS

How the world shares ideas.