

555-7101-205

CallPilot

1002rp Server Hardware Installation

Product release 3.0

Standard 1.0

November 2004

NORTEL
NETWORKS™

P0604537

CallPilot

1002rp Server Hardware Installation

Publication number:	555-7101-205
Product release:	3.0
Document release:	Standard 1.0
Date:	November 2004

Copyright © 2004 Nortel Networks, All Rights Reserved

Information is subject to change without notice. Nortel Networks reserves the right to make changes in design or components as progress in engineering and manufacturing may warrant.

The process of transmitting data and call messaging between the CallPilot server and the switch or system is proprietary to Nortel Networks. Any other use of the data and the transmission process is a violation of the user license unless specifically authorized in writing by Nortel Networks prior to such use. Violations of the license by alternative usage of any portion of this process or the related hardware constitutes grounds for an immediate termination of the license and Nortel Networks reserves the right to seek all allowable remedies for such breach.

This page and the following page are considered the title page, and contain Nortel Networks and third-party trademarks.

*Nortel Networks, the Nortel Networks logo, the Globemark, and Unified Networks, BNR, CallPilot, DMS, DMS-100, DMS-250, DMS-MTX, DMS-SCP, DPN, Dualmode, Helmsman, IVR, MAP, Meridian, Meridian 1, Meridian Link, Meridian Mail, Norstar, SL-1, SL-100, Succession, Supernode, Symposium, Telesis, and Unity are trademarks of Nortel Networks.

3COM is a trademark of 3Com Corporation.

ADOBE is a trademark of Adobe Systems Incorporated.

ATLAS is a trademark of Quantum Corporation.

BLACKBERRY is a trademark of Research in Motion Limited.

CRYSTAL REPORTS is a trademark of Seagate Software Inc.

EUDORA is a trademark of Qualcomm.

eTrust and InoculateIT are trademarks of Computer Associates Think Inc.

DIRECTX, EXCHANGE.NET, FRONTPAGE, INTERNET EXPLORER, LINKEXCHANGE, MICROSOFT, MICROSOFT EXCHANGE SERVER, MS-DOS, NETMEETING, OUTLOOK, POWERPOINT, VISUAL STUDIO, WINDOWS, WINDOWS MEDIA, and WINDOWS NT are trademarks of Microsoft Corporation.

GROUPWISE and NOVELL are trademarks of Novell Inc.

LOGITECH is a trademark of Logitech, Inc.

MCAFEE and NETSHIELD are trademarks of McAfee Associates, Inc.

MYLEX is a trademark of Mylex Corporation.

NETSCAPE COMMUNICATOR is a trademark of Netscape Communications Corporation.

NOTES is a trademark of Lotus Development Corporation.

NORTON ANTIVIRUS and PCANYWHERE are trademarks of Symantec Corporation.

QUICKTIME is a trademark of Apple Computer, Inc.

RADISYS is a trademark of Radisys Corporation.

SLR4, SLR5, and TANDBERG are trademarks of Tandberg Data ASA.

SYBASE is a trademark of Sybase, Inc.

TEAC is a trademark of TEAC Corporation

US ROBOTICS, the US ROBOTICS logo, and SPORTSTER are trademarks of US Robotics.

WINZIP is a trademark of Nico Mark Computing, Inc.

XEON is a trademark of Intel, Inc.

Publication history

November 2004	Release 3.0, Standard 1.0
September 2004	Release 3.0, Preliminary 2.0
July 2004	Release 3.0, Preliminary 1.0
May 2004	Release 3.0, Draft 0.01
October 2003	Release 2.5, Standard 1.0
July 2003	Release 2.5, Preliminary 1.1; EMC info added for ELAN and CLAN
June 2003	Release 2.5, Preliminary 1.0
April 2003	Release 2.5, Draft 1.0
February 2003	Preliminary for CallPilot 2.02 has a new appendix describing EMC emission level protection.
October 2002	Standard 1.0 of <i>CallPilot Installation and Configuration, 1002rp Server Hardware Installation</i> is issued for general release.

Contents

1	1002rp server description	9
	Server features	10
	Slot assignments	15
	IRQ mapping table	18
	Network connectivity	20
	Supported peripheral devices	25
2	Preparing for installation	27
	Installation overview.	28
	Unpacking the 1002rp server	31
	Removing the front bezel and server cover	33
	Inspecting the server interior	37
3	Power supply installation	39
	Safety precautions.	40
	Installing the second power supply module (AC or DC)	41
	DC wire gauge tables	44
	DC rack cabling	46
	About the power distribution unit.	49
	Bringing power and ground into the PDU	51
4	Installing the server and connecting the peripheral devices	53
	Installing the server.	54
	Preparing the modem	55
	Connecting peripherals to the server	59
	Connecting the server to the ELAN (Meridian 1 or Succession 1000)	62
	Connecting the server to the CLAN (optional).	65
	Installing the Nortel Networks software feature dongle.	67
	Connecting the server to power	69

A EMC emission level protection for the 1002rp Server 73

Index

Index 75

Chapter 1

1002rp server description

In this chapter

Server features	10
Slot assignments	15
IRQ mapping table	18
Network connectivity	20
Supported peripheral devices	25
Reference documents	26

Server features

Introduction

This section provides a general overview of the 1002rp server.

Server dimensions and weight

Height	320 mm (12.5 in.)
Width	483 mm (19 in.)
Depth (distance from front to back)	
■ without front bezel	495 mm (19.5 in.)
■ with front bezel	533 mm (21 in.)
Weight of fully loaded system	45.5 kg (100 lb)

Environmental specifications

Environmental condition	Specification
Operating temperature	10°C to 35°C (50°F to 95°F) Maximum rate of change must not exceed 10°C (50°F) per hour.
Non-operating (storage) temperature	-40°C to 70°C (-40°F to 158°F)
Non-operating humidity	95%, non-condensing at 30°C (86°F)
Altitude	1829 m (6000 ft)
Electrostatic discharge	15 kV or more
Acoustic noise	50 dBA in a typical office ambient temperature (18°C to 25°C [64.4°F to 77°F])
Operating shock	No errors with a half sine wave shock of 2G (with 1 millisecond duration)
Handling drop	Operational after a free fall from 450 mm to 600 mm (18 in. to 24 in.) (depending on weight)

Front panel features (front view without the front bezel)

The front view of the 1002rp server chassis shows redundant dual fans to the left and the right of the status panel. The left drive bay holds six SCSI hard drives with hot-pluggable carriers. The media drive bay, located to the right, houses the CD-ROM, tape drive, and floppy disk drive.

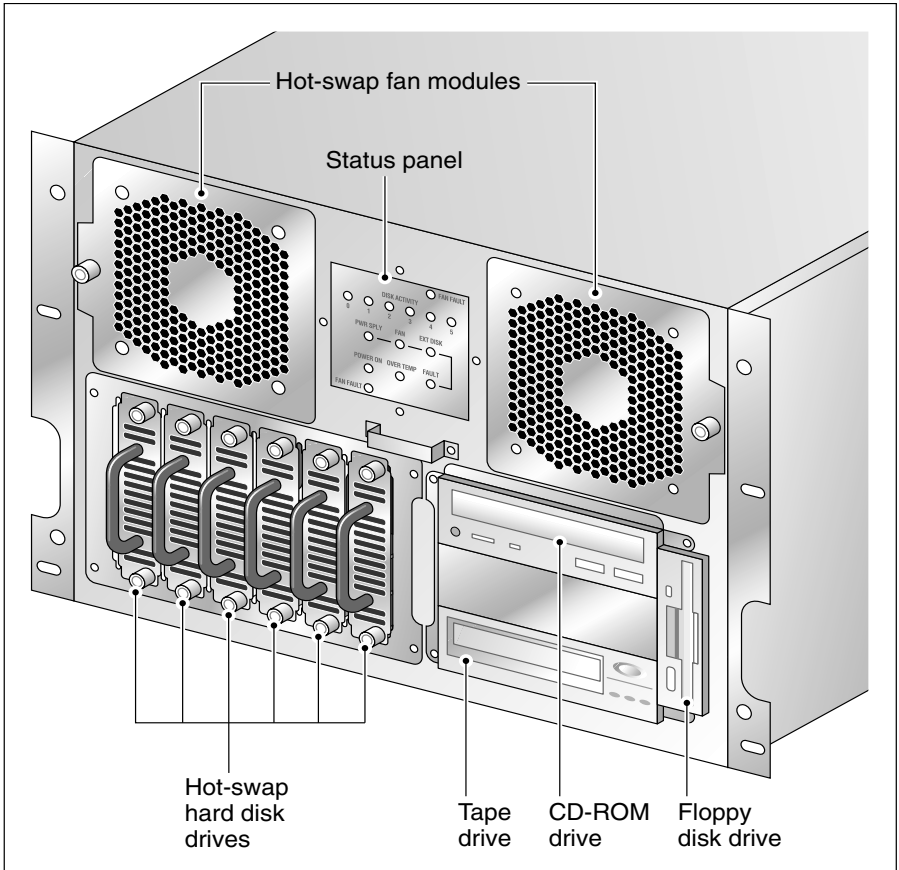

G101750

Alarm board

The alarm board is located under the baseboard. It connects to the status display panel on the front.

Rear panel diagram

Note: The following diagram shows the slot locations in the rear panel, and the power switch and power input for an AC server. The rest of the diagram is the same for AC or DC servers.

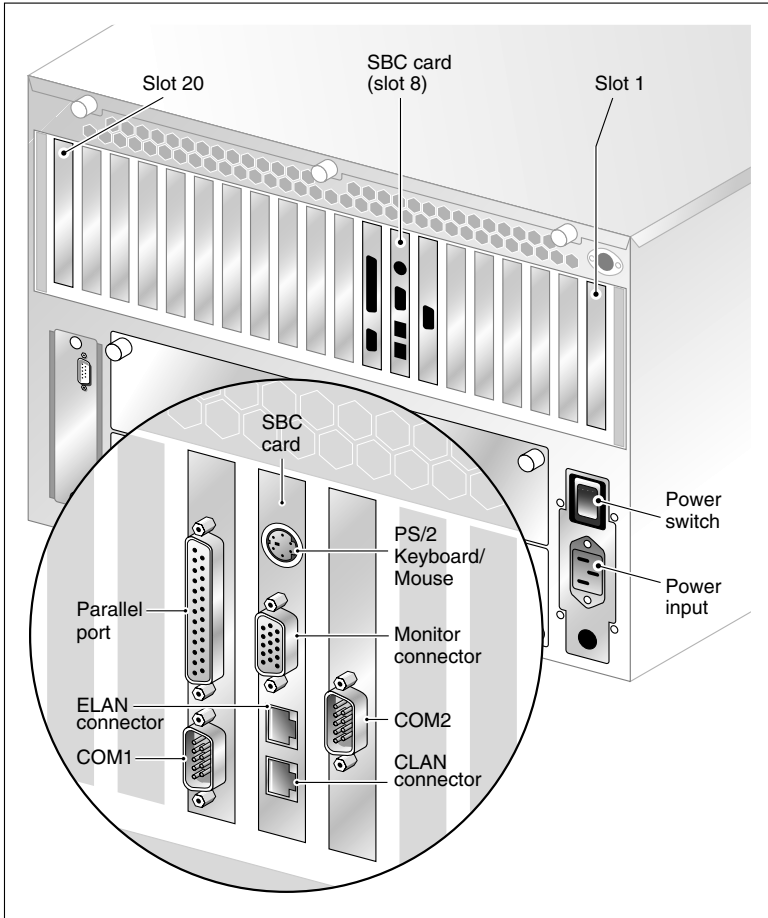

G101648

Overhead view of empty server showing PCI and ISA connectors

The following diagram shows the location of the PCI, SBC, and ISA connectors inside the server. The view in the diagram is from the rear of the server. For slot assignments, see “Slot assignments” on page 15. You must be able to identify slot locations for later steps in the CallPilot installation.

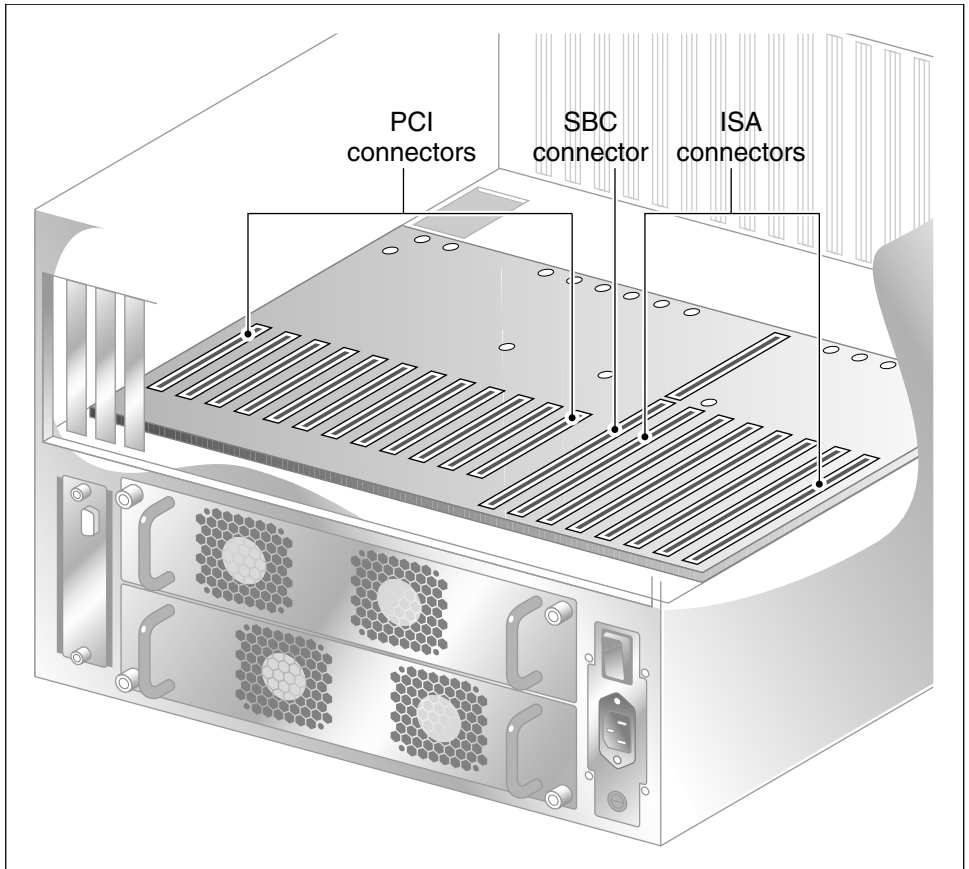

G101740

Slot assignments

Introduction

The slot assignment tables show the following:

- the physical location of boards inside the server, relative to other boards
- the order in which boards are installed (for example, board #1, 2, 3)
- how the boards are represented in some CallPilot Manager applications (such as the Maintenance Administration page)
- the maximum capacity for each switch connectivity

Note: Your server may vary depending on what was ordered from Nortel Networks. Therefore, your server may not have all of the slots populated.

Slot definition and slot numbering

In these tables, the term slot refers to the available slot openings in the chassis, not the PCI or ISA connectors inside the server.

Look at the server from the rear (see “Rear panel diagram” on page 13). The slots are numbered from right to left, 1 to 20. Now, look at the server from the front. The slots are numbered from left to right.

1002rp slot assignments

Slot number	CallPilot-assigned board label^a	Meridian 1	Succession 1000
Slot 1	BRD01	Not used	Not used
Slot 2	BRD02	Not used	Not used
Slot 3	BRD03	Not used	Not used
Slot 4	BRD04	Not used	Not used
Slot 5	BRD05	Not used	Not used
Slot 6	BRD06	Not used	Not used
Slot 7	BRD07	Reserved for COM2 I/O bracket	Reserved for COM2 I/O bracket
Slot 8 ^b	BRD08	Single board computer	Single board computer
Slot 9	BRD09	Reserved for COM1 and parallel port I/O bracket	Reserved for COM1 and parallel port I/O bracket
Slot 10	BRD10	PCI RAID controller	PCI RAID controller
Slot 11	BRD11	MPB16-4 or MPB96 board #1	MPB16-4 or MPB96 board #1
Slot 12 ^c	BRD12	MPB16-4 or MPB96 board #2 (optional)	MPB16-4 or MPB96 board #2 (optional)

Slot number	CallPilot-assigned board label^a	Meridian 1	Succession 1000
Slot 13	BRD13	MPB16-4 or MPB96 board #3 (optional)	MPB16-4 or MPB96 board #3 (optional)
Slot 14	BRD14	MPB16-4 or MPB96 board #4 (optional)	MPB16-4 or MPB96 board #4 (optional)
Slot 15	BRD15	MPB16-4 board #5 (optional)	MPB16-4 board #5 (optional)
Slot 16	BRD16	MPB16-4 board #6 (optional)	MPB16-4 board #6 (optional)
Slot 17	BRD17	MPB16-4 board #7 (optional)	MPB16-4 board #7 (optional)
Slot 18	BRD18	MPB16-4 board #8 (optional)	MPB16-4 board #8 (optional)
Slot 19	BRD19	Not used	Not used
Slot 20	BRD20	Not used	Not used

a. On some CallPilot Manager screens, the CallPilot-assigned board label is displayed. This label corresponds to the slot number. For example, BRD12 refers to the board in slot 12.

b. The SBC card includes two onboard NICs (for ELAN and CLAN) and an onboard video card. The NIC and monitor connectors are on the SBC faceplate.

c. For Meridian 1 and Succession 1000, the first MPB16-4 board must be installed in slot 11.

IRQ mapping table

Introduction

The following table displays the assignments for each interrupt request (IRQ) line with the associated slot or device. You do not need this information for installation, but you may need it for troubleshooting.

Note: IRQs 9, 10, 11, and 15 are assigned to system PCI slots rather than to specific devices.

IRQ	Slot or device
0	Timer
1	Keyboard
2	System/Unused
3	Serial port 2 (COM2)
4	Serial port 1 (COM1)
5	Available
6	Floppy controller
7	Parallel port (LPT1)
8	Real Time Clock
9	Assigned to slots 9, 15, and 20
10	Assigned to slots 10, 13, and 19
11	Assigned to slots 11, 14, and 17
12	PS/2 mouse

IRQ	Slot or device
13	Math coprocessor
14	Primary EIDE controller
15	Assigned to slots 12, 16, and 18

Network connectivity

Introduction

This section describes how the 1002rp server can be integrated into your network. The integration depends on the type of switch you are using.

ATTENTION

To secure the CallPilot server from unauthorized access, ensure that the CallPilot network is inside your organization's firewall.

Sample network setup: Meridian 1

The following diagram shows a CallPilot server sample network setup with a Meridian 1 switch. The Meridian 1 switch can be one of the following:

- Option 11C or Option 11C Mini
- Option 51C
- Option 61C
- Options 81 and 81C

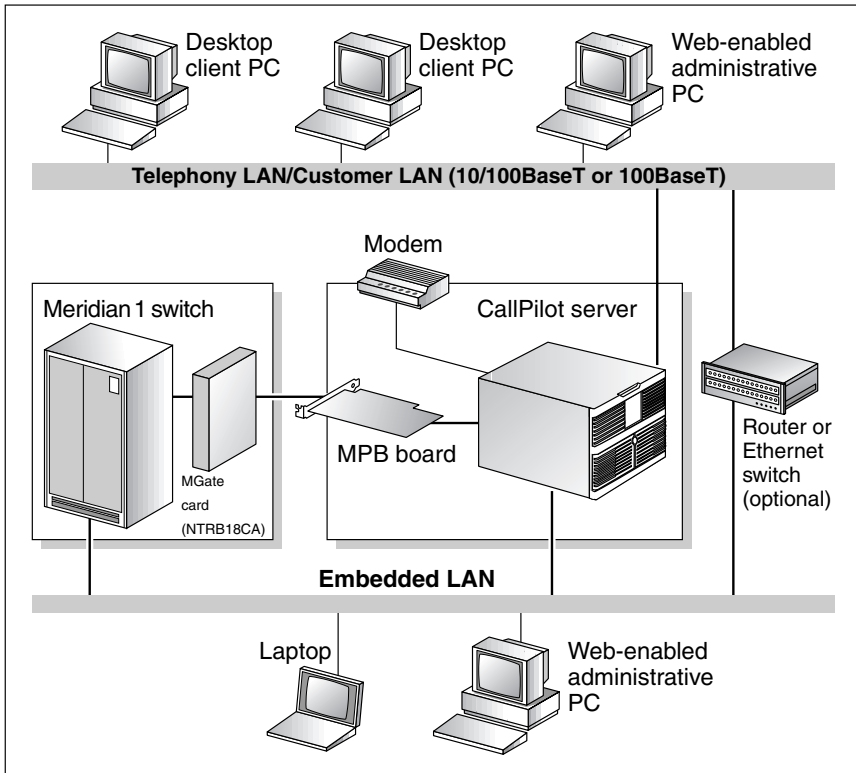

G101626

Sample network setup: Succession 1000

The following diagram shows a CallPilot server network setup with a Succession 1000 system.

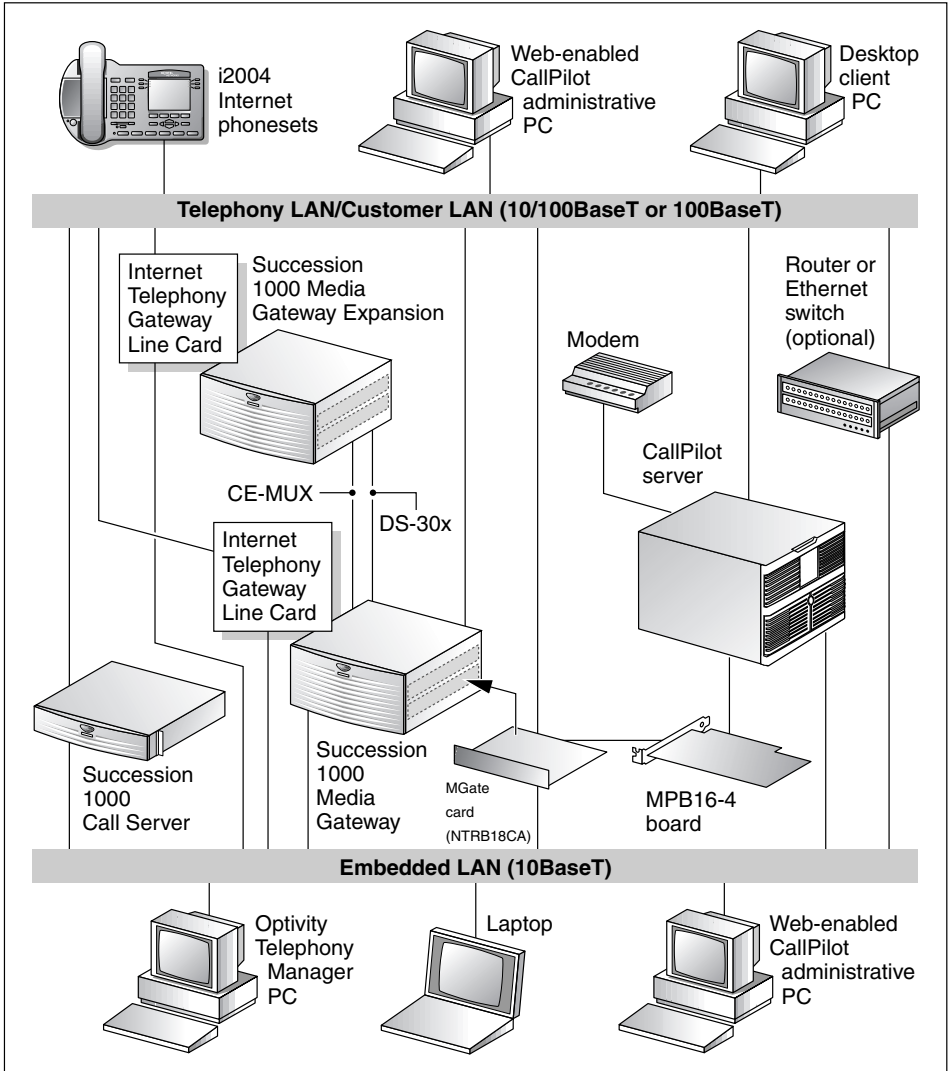

G250017

In this illustration, the telephony LAN (TLAN) provides IP connectivity between the Succession 1000 system and the i2004 Internet phonesets. The connection between the call server and media gateway can be point-to-point, or it can be through the LAN, if the system is installed in a distributed data network.

For information about the Succession 1000 system and i2004 Internet phoneset bandwidth and network requirements, refer to the *Succession Communication Server for Enterprise 1000 Planning and Installation Guide* (553-3023-210).

Switch connectivity

For more details about how the 1002rp server and switch connection is established, refer to the *Installation and Configuration Task List* (555-7101-210).

CallPilot ELAN and CLAN network setup

The 1002rp server provides 10/100Base-T Ethernet connectivity through NICs installed in the server. See “Slot assignments” on page 15 for details on the location of NICs. The function of each NIC is described below: The function of the NIC varies based on switch connectivity, as described below:

Meridian 1 or Succession 1000 systems

- One NIC provides connectivity to the ELAN.

For information about the purpose and requirements of the ELAN, see “About the ELAN (Meridian 1 and Succession 1000 only)” in the *Installation and Configuration Task List* (555-7101-210).

- A second NIC is optional.

This optional NIC is required only for Meridian 1 or Succession 1000 systems that require a CLAN connection (in addition to the ELAN connection). The CLAN provides data connectivity between desktop and web messaging clients, web-enabled administrative PCs, and the CallPilot server.

Network requirements

Appropriate networking equipment must be available for both the CLAN and ELAN.

The CLAN and ELAN must be properly configured for correct CallPilot operation. To ensure correct configuration, Nortel Networks recommends that you consult a network specialist.

ATTENTION

For important considerations about using the ELAN in your network, see “About the ELAN (Meridian 1 and Succession 1000 only)” in the *Installation and Configuration Task List* (555-7101-210).

Remote access connectivity

The RS-232 COM1 connector on the rear of the 1002rp server provides the connection to an external modem. The modem allows administrators and technical support personnel to administer the 1002rp server from a remote location.

pcAnywhere is used to establish the remote access connection to the server.

Supported peripheral devices

Introduction

This section identifies external devices that are supported by the 1002rp server.

Device	Description
Modem	<p>A 56-Kbit/s external modem (NTRH9078) provides remote access to the 1002rp server. The modem connects to the RS-232 COM1 connector on the rear of the server.</p> <p>Since the modem is an external device, it requires its own AC power source.</p>
Ethernet hub	<p>A 10Base-T Ethernet hub provides the ELAN connection between the 1002rp server and the Meridian 1 switch or Succession 1000 system. The customer can supply a hub or switch from third-party vendors or from Nortel Networks.</p> <p>Since the hub is an external device, it requires an AC power source.</p> <p>ATTENTION</p> <p>To comply with EMC radiation requirements, a Class A hub must be located 10 m (33 ft) away from the 1002rp server. Shielded Ethernet cables must be used.</p>
Monitor, keyboard, and mouse	<ul style="list-style-type: none"> <li data-bbox="370 1153 732 1181">■ 14-in. monitor: NTRH9011 <li data-bbox="409 1198 1037 1259">Since the monitor is an external device, it requires its own AC power source. <li data-bbox="370 1276 678 1303">■ Keyboard: NTRH9013 <li data-bbox="370 1321 645 1348">■ Mouse: NTRH9014

Reference documents



CallPilot Customer Documentation Map

NTP Number 555-7101-(nnn)

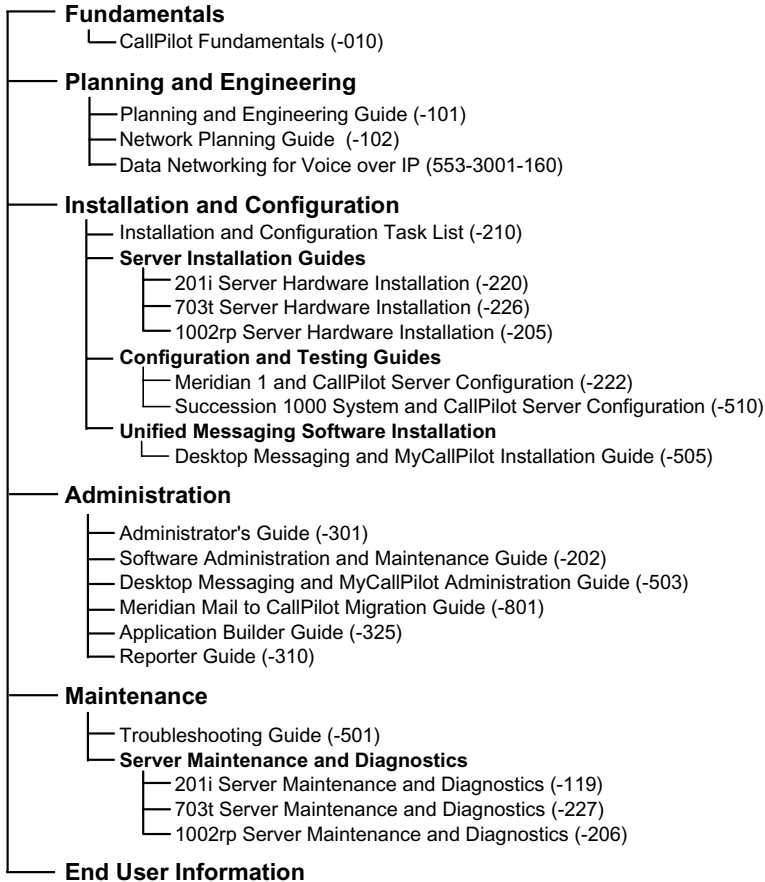

End User Cards

Unified Messaging Quick Reference Card Unified Messaging Wallet Card Command Comparison Card A-Style Command Comparison S-Style Menu Interface Quick Reference Card Alternate Command Interface Quick Reference Card

End User Guides

Multimedia Messaging User Guide Speech Activated Messaging User Guide Desktop Messaging User Guide for Microsoft Outlook Desktop Messaging User Guide for Lotus Notes Desktop Messaging User Guide for Novell Groupwise Desktop Messaging User Guide for Internet Clients MyCallPilot User Guide
--

Chapter 2

Preparing for installation

In this chapter

Installation overview	28
Unpacking the 1002rp server	31
Removing the front bezel and server cover	33
Inspecting the server interior	37

Installation overview

Introduction

This section provides an overview of the steps required to install the 1002rp server and peripheral devices.

Installation checklist

The following checklist identifies the tasks that must be performed when installing the CallPilot server. For detailed instructions, see Chapter 4, “Installing the server.” When you are finished with the installation, continue with the *Installation and Configuration Task List* (555-7101-210).

Step	Description	Check
1	Ensure that you have reviewed the “Installing CallPilot” section in the <i>Installation and Configuration Task List</i> (555-7101-210), and completed stage 1 of the “Installation checklist.”	<input type="checkbox"/>
2	Unpack the server, and ensure you have all the items you need (see page 31). Complete the following checklists that are provided in the <i>Installation and Configuration Task List</i> (555-7101-210): <ul style="list-style-type: none"> ■ “CallPilot software media and documentation checklist” ■ “CallPilot server hardware checklist” 	<input type="checkbox"/>
3	Remove the front bezel and server cover, and inspect the interior (see pages 33 and 37).	<input type="checkbox"/>
4	Replace the server cover.	<input type="checkbox"/>
5	Install the power supply modules in the server (see page 41).	<input type="checkbox"/>
6	For a DC-powered server, set up the DC power source (see page 44).	<input type="checkbox"/>

Step	Description	Check
7	Place the 1002rp server in the chosen location (see page 54).	<input type="checkbox"/>
8	Replace the front bezel (see page 36).	<input type="checkbox"/>
9	Set the DIP switches on the modem (see page 55).	<input type="checkbox"/>
10	<p>Connect the 1002rp server and devices as follows:</p> <ul style="list-style-type: none"> <li data-bbox="197 432 904 456">■ Connect the monitor, keyboard, and mouse (see page 59). <input type="checkbox"/> <li data-bbox="197 485 633 509">■ Connect the modem (see page 55). <input type="checkbox"/> <li data-bbox="197 537 930 603">■ Connect the 1002rp server to the ELAN hub (Meridian 1 or Succession 1000 only) [see page 62]. <input type="checkbox"/> <p>ATTENTION To comply with EMC radiation requirements, a Class A hub must be located 10 m (33 ft.) away from the 1002rp server. Shielded Ethernet cables must be used.</p> <p>Note: If you are connecting the optional CLAN, do not power up unless your anti-virus programs and Nortel Networks security updates are installed first. <input type="checkbox"/></p> <ul style="list-style-type: none"> <li data-bbox="197 903 930 968">■ Connect the 1002rp server to the CLAN hub (optional) [see page 65]. <input type="checkbox"/> <p>ATTENTION To comply with EMC radiation requirements, a Class A hub must be located 10 m (33 ft.) away from the 1002rp server. Shielded Ethernet cables must be used.</p> <ul style="list-style-type: none"> <li data-bbox="197 1142 799 1166">■ Install the software feature dongle (see page 67). <input type="checkbox"/> <li data-bbox="197 1195 889 1260">■ Connect the power cords for all devices, and then power them up. <input type="checkbox"/> 	
11	Start the 1002rp server (see page 69).	<input type="checkbox"/>

Conventions for warnings

You may encounter the following types of warnings in this guide. Do not ignore them.



DANGER

Risk of electric shock

Warns you of an immediate electrical hazard which, if not avoided, will result in shock, serious injury, or death.



WARNING

Risk of personal injury

Warns you of a situation in which you can be injured if instructions are not followed exactly as stated.



CAUTION

Risk of equipment damage

Alerts you to situations where data can be lost or damaged, equipment can be damaged, actions can result in service interruption, and productive time can be lost.

ATTENTION

Provides information that is essential to the completion of a task.

Unpacking the 1002rp server

Introduction

Follow this procedure to unpack the server and peripherals.



WARNING

Risk of personal injury

The 1002rp CallPilot server weighs approximately 34 kg (75 lb) as shipped from manufacturing. To prevent personal injury, have someone help you to unpack and position the server.

To unpack the equipment

ATTENTION

As you unpack each item, check it off against the packing list, as well as against the following checklists provided in the *Installation and Configuration Task List* (555-7101-210):

- “CallPilot software media and documentation checklist”
- “CallPilot server hardware checklist”

- 1 Carefully open the cardboard carton containing the server.
- 2 Remove the server from the carton and set it on the floor.
- 3 Carefully open the cartons containing the monitor, keyboard, mouse, modem, and ELAN hub (if supplied), and set the peripherals aside.
- 4 Put all manuals, CD-ROMs, operating system disks, and any disks for peripherals in a safe place.

- 5 Save all packing materials and cartons in case you must return any equipment to the carrier.

What's next?

Remove the server cover so that you can inspect the interior of the server. See “Removing the front bezel and server cover” on page 33.

Removing the front bezel and server cover

Introduction

To access the server interior, you must remove both the front bezel and the server cover.

Two locked doors on the front of the server cover the front panel, including the CD-ROM drive and tape drive. These doors are part of the front bezel. You must unlock the front bezel doors before you can remove the bezel.

To remove the front bezel



CAUTION

Risk of equipment damage

Do not attempt to move or lift the server before removing the front bezel; the server can disengage from the bezel and fall.

- 1 Unlock and open the double doors of the front bezel. See A in the diagram below.
- 2 Firmly grasp the front bezel by the hand-holds on either side of the chassis, and pull the front bezel from the chassis.

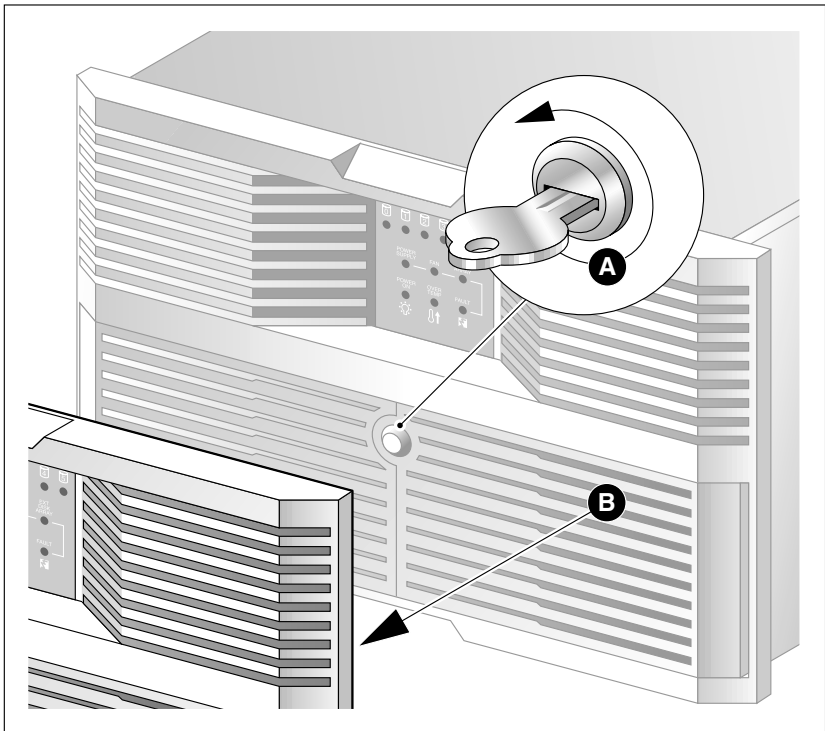

G101733

To remove the server cover



DANGER

Risk of electric shock

High current inside the chassis can cause severe injury.



CAUTION

Risk of equipment damage

Take precautions to protect internal components. Electrostatic discharge (ESD) can render boards damaged or unusable. Wear an ESD wrist strap.

- 1 Remove the front bezel (see page 34).
- 2 Loosen the three thumbscrews at the rear of the top cover.
- 3 Remove the server cover by pulling the cover toward the rear of the chassis, and then lifting it up and off.
- 4 Clip the lead from your ESD wrist strap to an unpainted metal section of the chassis.

What's next?

Continue with “Inspecting the server interior” on page 37.

To replace the front bezel after installation is complete

When the CallPilot server installation is complete and the server is in its final location, replace the front bezel.

- 1 Align the front bezel with the ball studs located at each faceplate corner.

See the diagram below:

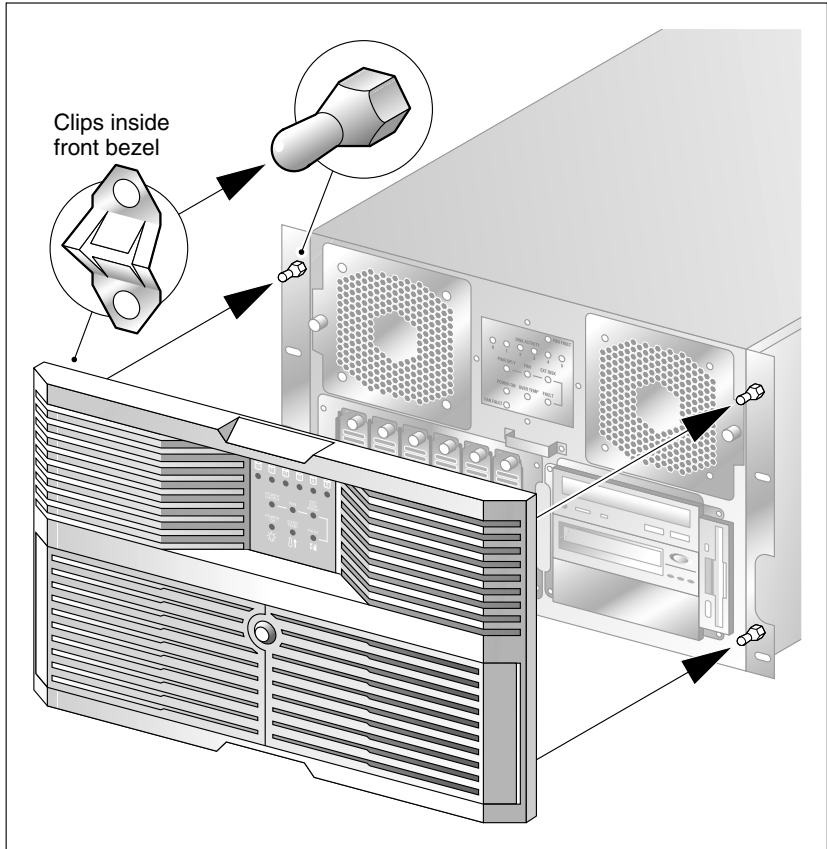

G101734

- 2 Apply pressure evenly until the bezel snaps onto each ball stud.
- 3 Close and lock the double doors of the front bezel.

Inspecting the server interior

Introduction

You should perform a visual inspection for loose components, foreign matter, or shipping damage inside the server.



CAUTION

Risk of equipment damage

When working with interior components, use an ESD wrist strap to protect static-sensitive components.

To inspect the server interior

- 1 Carefully check all the cards to ensure they are fully seated on the baseboard.
- 2 Check for any loose wires or foreign objects, such as loose screws, inside the chassis.
- 3 Review the slot locations (see “Slot assignments” on page 15).
- 4 Do one of the following:

IF	THEN
you observe any damage	contact your Nortel Networks technical support representative.
components have become loose	secure them. Refer to the procedures in the <i>Installation and Configuration Task List</i> (555-7101-210).

IF	THEN
you are satisfied that the 1002rp server has arrived at your site undamaged	replace the server cover and proceed with the hardware installation. See “Installation checklist” on page 28. Note: Do not reinstall the front bezel until the server is in its final location and the CallPilot installation is complete.

Chapter 3

Power supply installation

In this chapter

Safety precautions	40
Installing the second power supply module (AC or DC)	41
DC wire gauge tables	44
DC rack cabling	46
About the power distribution unit	49
Bringing power and ground into the PDU	51

Safety precautions

Equipment handling guidelines

External power equipment, such as an uninterruptible power supply (UPS), is usually very heavy. This equipment requires special handling procedures and additional personnel for unloading and installation. Be aware of weight distribution, and prevent the equipment room floor from being overly stressed.

Safety information

In DC systems, locate the service panel near the entry to the room containing the DC power system that supplies the server.



DANGER

Risk of electric shock

Procedures involving electrical connections must only be performed by qualified personnel.

Ensure that you obey all displayed warning notices on power equipment and connections.

Installing the second power supply module (AC or DC)

Introduction

One power supply module is shipped installed. The second power supply module must be installed on site.

AC versus DC systems

The power supply modules are similar in appearance for both AC and DC 1002rp servers. The procedures in this section apply to both AC and DC 1002rp servers.

About the power supply module

After the server is powered up (later in this guide), the power supply module LED indicates its status.

A green LED on the power supply module indicates that the module is working properly. If the LED is unlit or red, the module is failing or has failed. A problem with the power supply module is also indicated if an alarm sounds or the power supply LED on the front of the server turns red.

The diagram below shows the location of the power supply modules in a server that has two power supply modules installed:

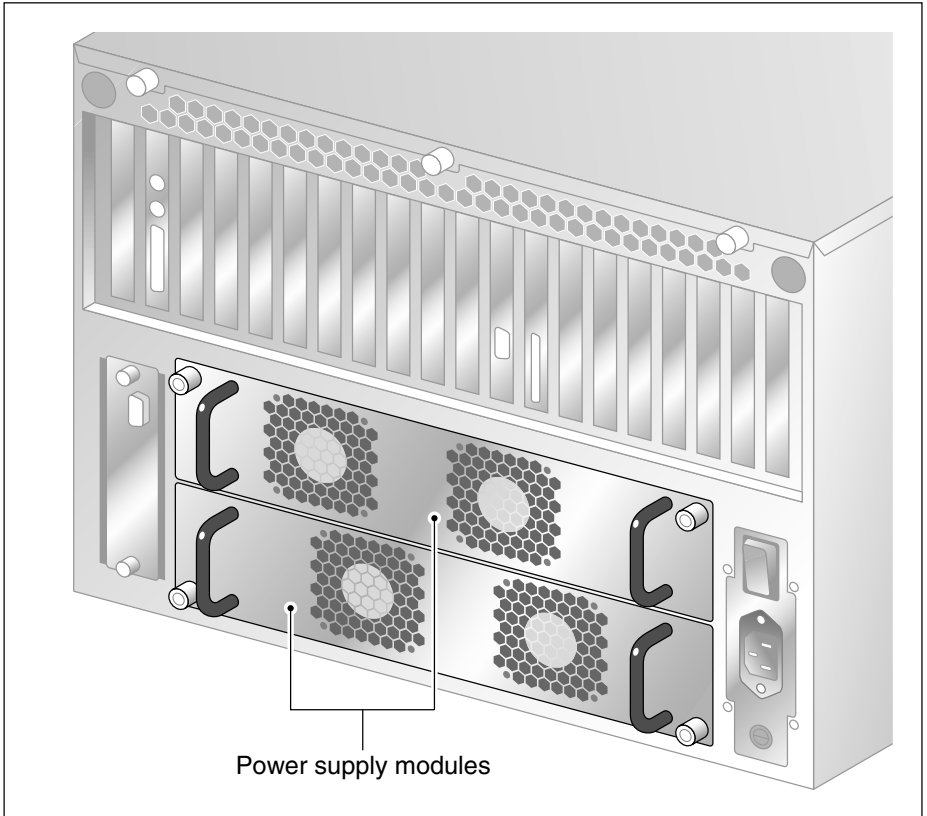

G101751

To install the power supply module



DANGER

Risk of electric shock

High current inside the chassis can cause severe injury.

The server is shipped with one power supply module installed in the bottom power supply bay. You must install the second power supply module, as described here:

- 1 Align the power supply module with the top power supply bay.
- 2 Slide the power supply module into the bay until the module is secured by its connector.

Use some force, if necessary.

- 3 Secure the power supply module to the chassis with two thumbscrews at the corners of the power supply faceplate.

What's next?

Do one of the following:

IF	THEN
this is an AC-powered server	continue with Chapter 4, "Installing the server," on page 54.
this is a DC-powered server	continue with "DC wire gauge tables," on page 44.

DC wire gauge tables

Introduction

The tables in this section specify the DC power feed wire requirements.

Cabinet and module DC feed recommended wire gauge specifications

Length	#10 AWG	#8 AWG	#6 AWG	Junction box #4 AWG	Junction box #4 AWG
0–30 m (100 ft)	yes	yes	yes	yes	yes
0–45 m (150 ft)	no	yes	yes	yes	yes
0–75 m (250 ft)	no	no	yes	yes	yes
0–135 m (450 ft)	no	no	no	yes	yes
0–210 m (700 ft)	no	no	no	no	yes
Over 210 m (700 ft)	no	no	no	no	no

Notes:

1. The cabinet and module ground wire specification is #10 AWG insulated green safety ground wire.
2. The cabinet conduit can be 19.1 mm (0.75-in.) or 31.8 mm (1.25-in.), and must be insulated from the cabinet ground.

Metric wire conversion

AWG No.	Industry standard nominal (sq mm)	Resistance at 20 C (Ohm/100 m)
2	35	0.05
4	25	0.08
6	16	0.13
8	10	0.20
10	6	0.33
12	4	0.63
14	2.5	1.00
16	1.5	1.40
18	1	2.00
20	0.75	2.90
22	0.5	4.60

DC rack cabling

The following photo shows typical rack power cabling:

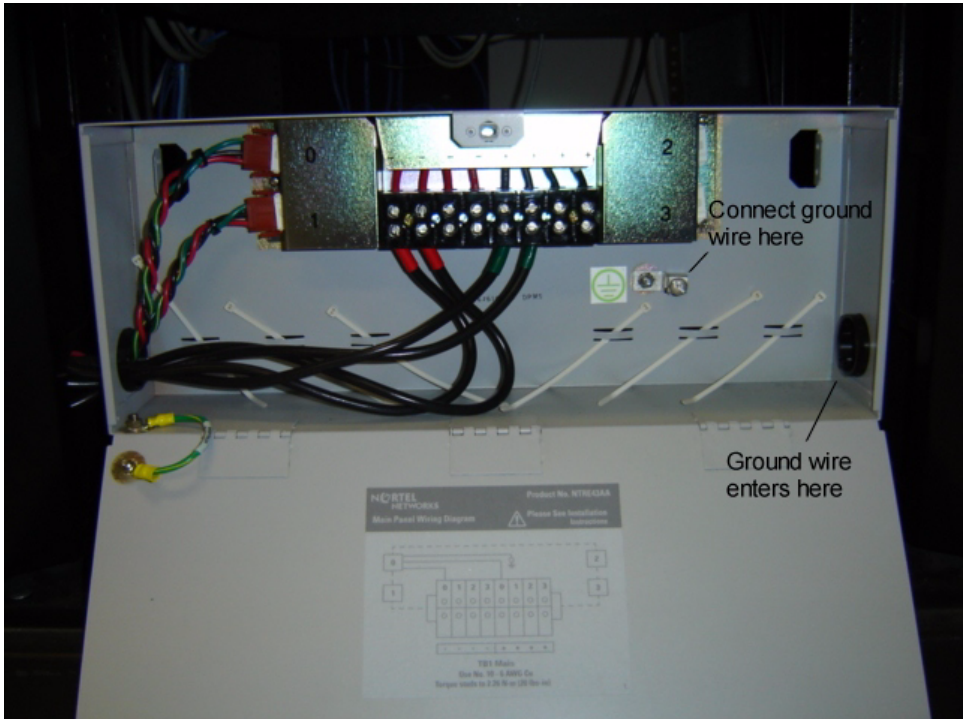

Note: The cables are marked with Red and Green tape. The cables with the Red tape connect to the Negative (-) Red side (on the left in the photo), and the cables with the Green tape connect to the Positive (+) Green side (on the right in the photo). The sides are identified on the power connections. The ground wire enters at the lower right and attaches to the ground lug.

Main panel wiring diagram with product number.

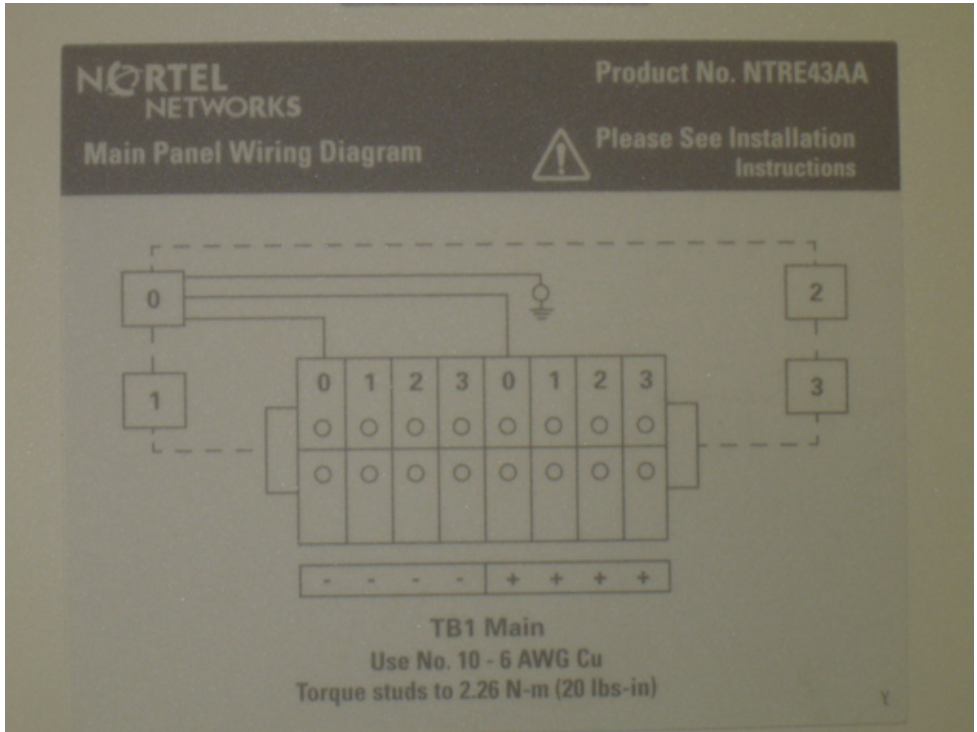

Rack power and grounding

To ensure a complete power and grounding installation:

- In rackmount server installations, ensure the CallPilot server chassis and equipment racks are isolated from other foreign sources of ground. Acceptable isolation methods include: isolation pads, grommets, washers, chassis side rail strips and non-conducting washers, etc.
- In rackmount server installations where other equipment is also installed in the same 19" rack, ensure that all equipment derives ground from the same service panel as CallPilot and the switch, whether or not the equipment is AC or DC powered.

-48 V dc power distribution rationale

- Minimum installation is one power distribution unit (PDU) with four 48 V dc branch circuits fused at 20 amperes.
- The customer must be able to shut off any branch, and every unit at the site will continue to function properly.
- DC-powered configuration fits into this scheme as follows:
 - Each PDU receives four branch circuits.
 - Each server receives a feed from each PDU and a different branch circuit.
- In this fashion, with dual hot-swappable power supplies, there is no single point of failure in the power system. For example, you can remove any power supply, including a PDU, and everything continues to work.
- This is applicable to either North American or European installation sites (with a 230 V ac inverter).
- The secondary rack supports four servers and follows a similar scheme.

About the power distribution unit

Introduction

A PDU is installed in a rack that has DC-powered servers. Power from the DC supply source enters the PDU and can then be distributed to one or more servers. A single PDU can supply DC power to four DC power supply modules. A server can have either one or two power supply modules installed. You can determine the number of PDUs to install in a rack by counting the number of power supply modules in each rack.

PDU power and grounding

To ensure a complete power and grounding installation:

- In rackmount DC-powered server installations, ensure the PDU (Power Distribution Unit for DC applications) is installed on the same rack as the CallPilot server. This is required since the main ground wire for the PDU is not insulated from the metal enclosure.

Multiple PDUs

A server operates on a single power supply module. Its total capacity is two installed power supply modules. The second power supply module is the redundant power supply module.

A PDU can distribute power to a maximum of four power supply units that can be installed in two or more servers. Therefore, if there are three or four servers installed in a rack, then you must install a second PDU.

Note: The power supply module installs in the server. It does not refer to a UPS, which is a separate unit on the rack.

PDU terminal blocks and wiring diagram

A PDU consists of eight terminal blocks within a metal enclosure. Before installing the PDU, connect the terminal blocks so that each output connector receives power from a separate -48 V dc branch circuit, as shown in the following diagram. Use AWG 10 wires for these connections.

Single PDU wiring diagram

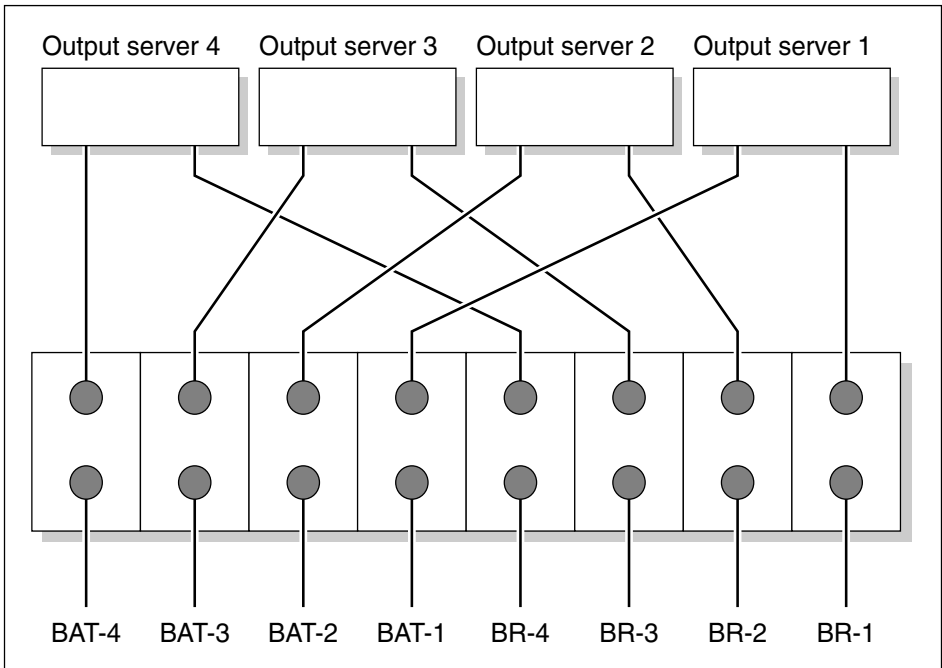

G101741

DC power input

DC power input into the distribution unit connects BAT-1 to BAT-4 and BR-1 to BR-4. Refer to the preceding diagrams for the location of these terminals. Connect the input wires before installing the PDU on the rack.

Bringing power and ground into the PDU

Introduction

Install BAT/BATRTN wires in pairs. Each pair of wires supplies voltages to a module through a power harness. The module harnesses are installed in the cabinet PDU and connected to the modules at the factory. See “About the power distribution unit” on page 49.

To bring DC power and ground into the PDU

- 1 If you are using a conduit, terminate the 32 mm (1-1/4 in.) or 19 mm (3/4 in.) conduit at the top rear of the cabinet or at the bottom front of the cabinet using the knockouts provided. The number of wire pairs you can run in each conduit depends on the wire gauge.

Note: To preserve ground integrity, the conduit must be insulated.

- 2 Select a power feed with a circuit breaker dedicated to each module, and identify it with an appropriate tag.
- 3 Select a wire size to suit the required feed length from the power source (see “DC wire gauge tables” on page 44).
- 4 Use pliers to strip 6 mm (1/4 in.) to 13 mm (1/2 in.) of the insulation from one end of all power and ground feed wires.
- 5 Undo the terminal block screws at (-) positions 0, 1, 2, and 3.
- 6 Insert the *red* wires into terminal block positions 0, 1, 2, and 3.
- 7 Secure the wires in the terminal block by tightening the screws.
- 8 Undo the terminal block screws at (+) positions 0, 1, 2, and 3.
- 9 Insert the *black* wires into terminal block positions 0, 1, 2, and 3.
- 10 Secure the wires in the terminal block by tightening the screws.
- 11 Select a #10 AWG green wire safety ground and attach it to the cabinet.
- 12 Measure the module ground continuity by touching one multimeter lead to any BATRTN terminal block connector and the other end to the GND terminal block connector. The measurement should be between 0–0.5 ohms.

Chapter 4

Installing the server and connecting the peripheral devices

In this chapter

Installing the server	54
Preparing the modem	55
Connecting peripherals to the server	59
Connecting the server to the ELAN (Meridian 1 or Succession 1000)	62
Connecting the server to the CLAN (optional)	65
Installing the Nortel Networks software feature dongle	67
Connecting the server to power	69

Installing the server

Introduction

Before you install the 1002rp server, ensure that the chosen location meets the requirements identified on the “Site inspection checklist” provided in the *Installation and Configuration Task List* (555-7101-210).

To install the server

Place the 1002rp server in its chosen location. If you are installing the server in a rack cabinet, follow the instructions that are provided with the slide rails.

Connect peripheral devices as described in the remainder of this chapter.



WARNING

Do not connect the server to the power yet.

Preparing the modem

Introduction

You require a modem to support remote dial-up access to the CallPilot server. The modem also enables Nortel Networks technical support to connect to your CallPilot server for troubleshooting purposes. Nortel Networks connects to your server only when you request technical assistance.

Required equipment

To install the modem, you need the following equipment:

- an RJ-11 analog phone cord
- a power adapter cord
- an analog line jack
- tweezers, or a screwdriver small enough to use to adjust DIP switches

The following modem has been provided with your server:

- an analog external U.S. Robotics 56-Kbit/s modem (NTRH9078) that includes a 25-pin male to 9-pin female shielded serial cable for your modem

Note: Ensure that you have the correct cable for your modem, as follows:

- 56-Kbit/s modem: A0841984

Modem DIP switches

Set the modem DIP switches before you connect the modem to the CallPilot server.

Note: This section applies only to the U.S. Robotics 56-Kbit/s external Sportster modem. If your modem is different, refer to the documentation for your modem.

The following diagram shows the key components of the external modem, including the location and required settings of the DIP switches:

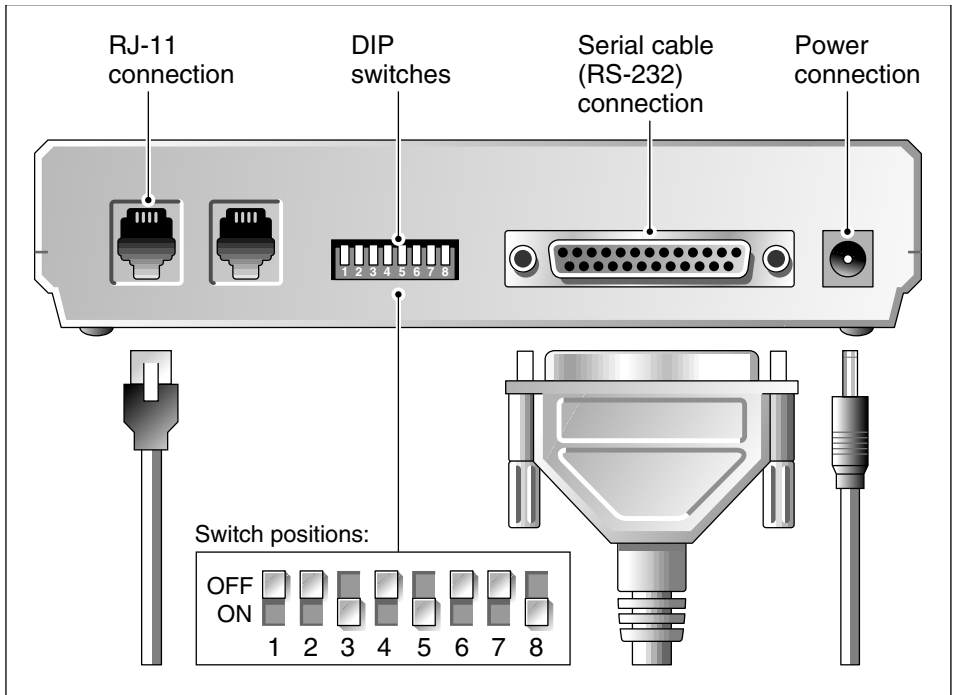

G101445

To set the modem DIP switches

Use a pair of tweezers or a small screwdriver to set the DIP switches as described in the Change to column of the following table:

Note: ON is down. OFF is up.

DIP switch	Default setting	Change to	Function
1	OFF	OFF	Data Terminal Ready (DTR) override <ul style="list-style-type: none"> ■ OFF: Normal DTR operations. (The computer must provide a DTR signal for the modem to accept commands. If DTR is dropped, the call is terminated.) ■ ON: The modem ignores DTR (override).
2	OFF	OFF	Verbal/numeric result codes <ul style="list-style-type: none"> ■ OFF: Verbal (word) results. ■ ON: Numeric results.
3	ON	ON	Result code display <ul style="list-style-type: none"> ■ OFF: Suppresses result codes. ■ ON: Enables result codes.
4	OFF	OFF	Command mode local echo suppression <ul style="list-style-type: none"> ■ OFF: Displays keyboard commands. ■ ON: Suppresses echo.
5	ON	ON	Auto answer suppression <ul style="list-style-type: none"> ■ OFF: The modem answers on the first ring, or higher if specified in NVRAM. ■ ON: Disables auto answer.

DIP switch	Default setting	Change to	Function
6	OFF	OFF	Carrier Detect (CD) override <ul style="list-style-type: none"> ■ OFF: The modem sends a CD signal when it connects with another modem; it drops the CD on disconnect. ■ ON: CD is always ON (override).
7	OFF	OFF	Power-on and ATZ reset software defaults <ul style="list-style-type: none"> ■ OFF: Loads Y or Y1 configuration from user-defined NVRAM. ■ ON: Loads &F0-Generic template from read-only memory (ROM).
8	ON	ON	AT command set recognition <ul style="list-style-type: none"> ■ OFF: Disables command recognition (dumb mode). ■ ON: Enables recognition (smart mode).

What's next?

Continue with “Connecting peripherals to the server” on page 59.

Connecting peripherals to the server

Rear panel connectors

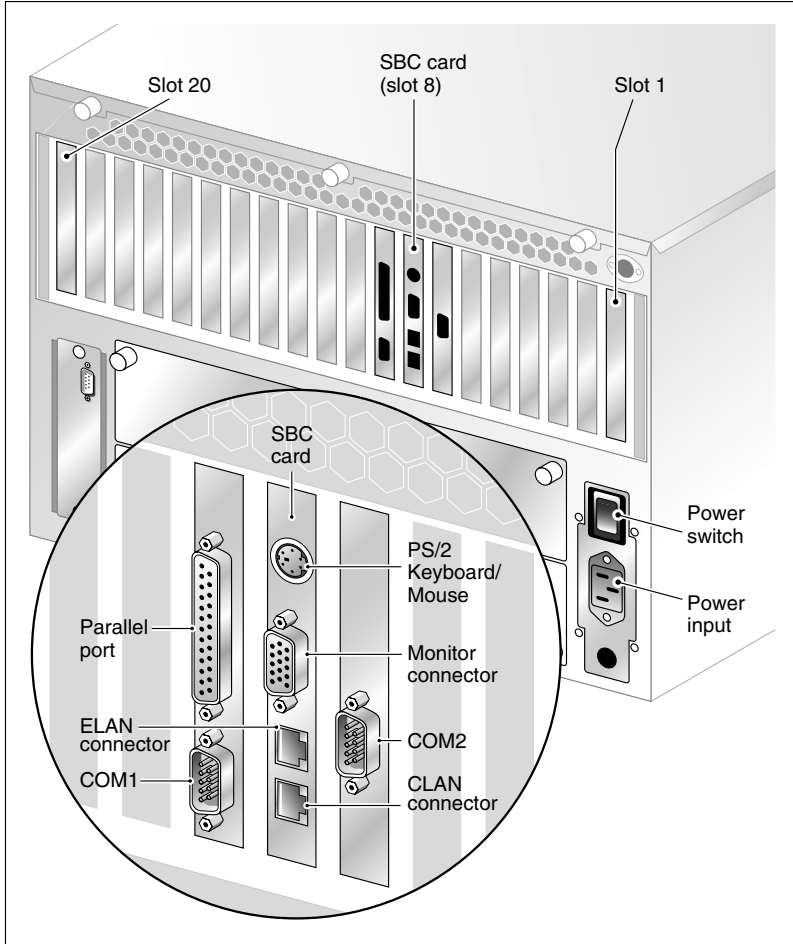

Note: The above diagram shows the power switch and power input for an AC server. The rest of the diagram is the same for AC or DC servers. For peripheral device connections, this picture applies to AC and DC servers.

To connect the mouse, keyboard, and monitor to the server

- 1 Place the monitor, keyboard, and mouse in the same location as the server.
- 2 Plug the keyboard/mouse dual cable into the PS/2 connector on the SBC card faceplate (see “Rear panel connectors” on page 59).
- 3 Plug the keyboard and mouse into the appropriate connectors on the keyboard/mouse dual cable.
- 4 Plug the monitor into the monitor connector on the SBC card. Tighten the screws on the connector.
- 5 Ensure that a single-point ground reference is available for all the power outlets serving the CallPilot server and its peripherals. Before the CallPilot server installation, a qualified electrician must implement the single-point ground reference requirement between the power outlets of the CallPilot server and the power outlets of the switch.
- 6 Connect the power cord to the monitor and plug the other end into a wall receptacle or power bar.

Note: Ensure that the power source is consistent with the SBC for all ancillary equipment.

- 7 Turn on the monitor.

To connect the modem to the server

- 1 Ensure that the modem AC power cord is not plugged in.
- 2 Connect the large 25-pin male connector to the back of the modem. Tighten the connector screws.
- 3 Connect the 9-pin female connector to COM1 at the rear of the server. Tighten the connector screws.
- 4 Connect one end of the telephone cable to the modem RJ-11 jack labeled LINE.
- 5 Connect the other end of the telephone cable to the RJ-11 jack in the wall.

- 6 Ensure that a single-point ground reference is available for all the power outlets serving the CallPilot server and its peripherals. Before the CallPilot server installation, a qualified electrician must implement the single-point ground reference requirement between the power outlets of the CallPilot server and the power outlets of the switch.
- 7 Connect the power cord to the modem, and plug the other end into a wall receptacle or power bar.

Note: Ensure that the power source is consistent with the SBC for all ancillary equipment.

- 8 Turn on the modem.

What's next?

Continue with “Connecting the server to the ELAN (Meridian 1 or Succession 1000)” on page 62.

Connecting the server to the ELAN (Meridian 1 or Succession 1000)

Introduction

ATTENTION _____
This section applies only if the 1002rp server connects to a Meridian 1 switch or Succession 1000 system.

Connect the CallPilot server to the Meridian 1 switch or Succession 1000 system using the ELAN.

ATTENTION _____
For important considerations about using the ELAN in your network, see “About the ELAN (Meridian 1 or Succession 1000 only)” in the *Installation and Configuration Task List* (555-7101-210).

ATTENTION _____
To comply with EMC radiation requirements, a Class A hub must be located 10 m (33 ft.) away from the 1002rp server. Shielded Ethernet cables must be used.

Media Access Control address

The Media Access Control (MAC) address is a unique number assigned to network cards and controllers. The procedure below asks you to record the ELAN MAC address. The MAC address is recorded on a label affixed to the back of the chassis.

To connect the server to the ELAN (Meridian 1 or Succession 1000)

- 1 See the diagram on page 59 to locate the ELAN Ethernet connector.
- 2 Locate the MAC address label on the back of the chassis that identifies the ELAN controller MAC address.
- 3 Record the MAC address on the Configuration Wizard worksheet that is provided in the *Installation and Configuration Task List* (555-7101-210).

You need the MAC address to identify the ELAN when running the Configuration Wizard to configure the CallPilot server.

- 4 Connect an RJ-45 network cable from the ELAN hub to the ELAN connector on the server.

Note: The ELAN hub is optional if you use a cross-over network cable to make a direct point-to-point connection from the server to the switch. However, if you choose to establish a direct point-to-point ELAN connection, no other device can connect to the ELAN.

- 5 At the switch, connect the ELAN network cable to an MAU (Ethernet) transceiver. Then complete the connection from the transceiver to the switch.



DANGER

Risk of fire hazard

MAU model NTRH9069 is not suitable for installation in ducts, plenums, or other spaces used for environmental air. Do not install it above a false ceiling or below a raised floor, unless it can be confirmed that these spaces are not used to convey environmental air.

What's next?

IF the server will	THEN
be connected to a CLAN	continue with page 65.
not be connected to a CLAN	continue with installing the software feature dongle. See page 67.

Connecting the server to the CLAN (optional)

Introduction

This section provides instructions to connect the server to the CLAN.

Note: The CLAN is optional. However, a CLAN is required to support desktop and web messaging users.

ATTENTION

To comply with EMC radiation requirements, a Class A hub must be located 10 m (33 ft.) away from the 1002rp server. Shielded Ethernet cables must be used.

Media Access Control address

The MAC address is a unique number assigned to network cards and controllers. The procedure below asks you to record the CLAN MAC address. The MAC address is recorded on a label affixed to the back of the chassis.

To connect the server to the CLAN

- 1 See the diagram on page 59 to locate the CLAN network card.
- 2 Locate the MAC address label on the back of the chassis that identifies the CLAN controller MAC address.
- 3 Record the MAC address on the Configuration Wizard worksheet that is provided in the *Installation and Configuration Task List* (555-7101-210).

You need the MAC address to identify the CLAN when running the Configuration Wizard to configure the CallPilot server.

Note: When connecting the optional CLAN, do not power up unless your anti-virus programs and Nortel Networks security updates are installed first.

- 4 Connect an RJ-45 network cable from the CLAN hub to the CLAN connector.

What's next?

Continue with “Installing the Nortel Networks software feature dongle” on page 67.

Installing the Nortel Networks software feature dongle

Introduction

The software feature key is a security device that stores the unique serial number of the server. The feature key is embedded in the Nortel Networks software feature dongle, which plugs into the parallel port.

An illustration of the software feature key embedded in the software feature dongle is shown below:

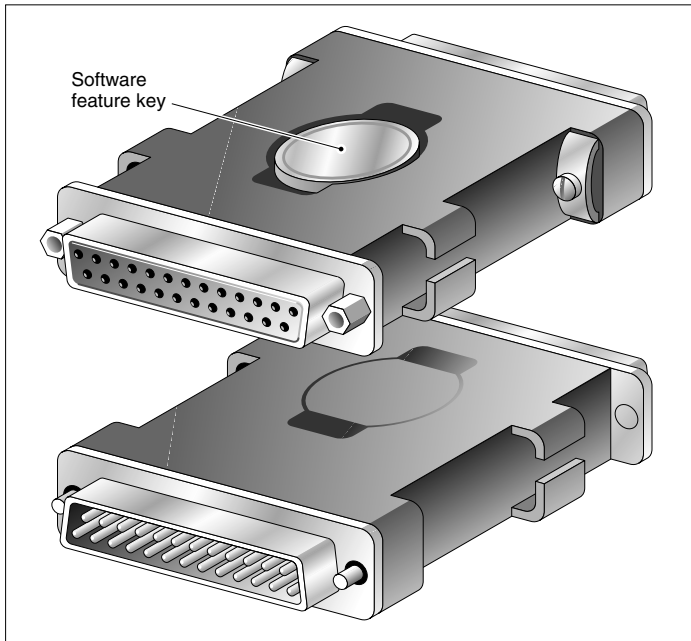

G101738

Requirements

For installation, you require a Phillips No. 1 screwdriver.

To install the software feature dongle

- 1 Ensure that there is no cable connected to the parallel port.
Note: The parallel port is also known as the printer port or LPT1. It is located at the back of the server. See the diagram on page 59.
- 2 If the software feature key is not pre-installed in the dongle, remove it from the plastic bag and carefully insert it into the software feature slot on the dongle. Make sure that the clips secure it properly and that the Nortel Networks logo faces outwards.
- 3 Plug the male end of the adapter into the parallel port.
- 4 Tighten the connector screws.

What's next?

Continue with “Connecting the server to power” on page 69.

Connecting the server to power

Before you begin

Ensure that proper power and grounding are available for all the power outlets serving the CallPilot server and its associated peripherals. Power for these devices must be wired and fused independently of all other receptacles and referenced to the same ground as the PBX system.

A qualified electrician must implement the single-point ground reference as required between the power outlets of the CallPilot server and the power outlets of the switch.

Provide a sufficient number of properly grounded power outlets or power bars for all equipment. For more information, refer to grounding and power requirements in this document and in the *Planning and Engineering Guide* (555-7101-101).

The single-point ground (SPG) required by the system can be an isolated ground (IG) bus or ac equipment ground (ACEG) bus in the service panel or transformer. The system must be connected to safety ground/protective earth in accordance with NEC requirements. For international use, the system must be connected to safety ground/protective earth in accordance with Paragraph 2.5 of EN60950/IEC950.

Note: Refer to *Large System: Planning and Engineering* (553-3021-120) for a complete description of approved ground sources and methods. Insulated ground wire must be used for system grounding.

Before you connect the server to the power source, review the following diagram to ensure that all peripheral hardware devices are in place.

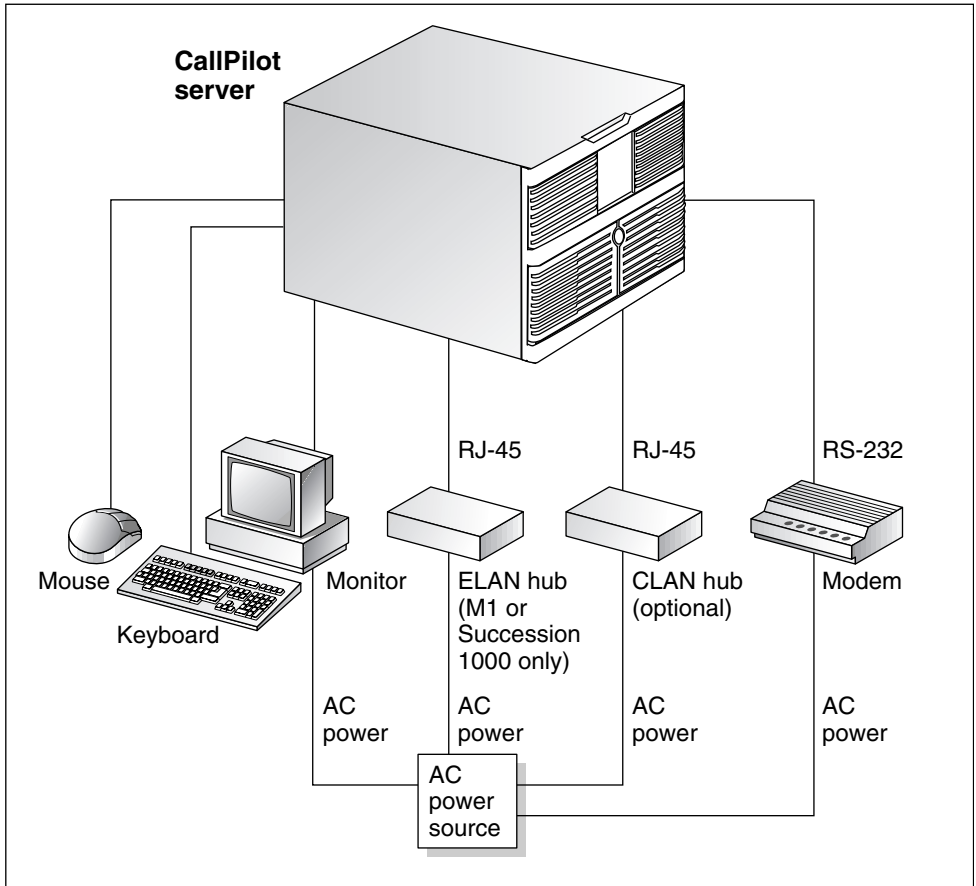

G250018

Note: For details on the DC power source for 1002rp DC servers, see Chapter 3, “Installing the second power supply module (AC or DC).”

To connect the 1002rp AC server to power



WARNING

Risk of personal injury, risk of hardware failure

The power outlets that are used by the CallPilot server and its peripheral devices must be connected to the same single-point ground reference as the one used by the switch with MGate cards (NTRB18CA) connected to the CallPilot server. If this requirement is not met, power transients can cause personal injury or hardware failure or both. Refer to the *Installation and Configuration Task List* (555-7101-210) for more information on single-point grounding requirements.

- 1 Plug the server AC power cord into the server rear panel.
- 2 Plug the other end into a wall receptacle or power bar.

To connect the 1002rp DC server to power



DANGER

Risk of electrical shock

- Only qualified personnel can alter electrical connections.
- Ensure the power distribution unit (PDU) is turned off until you are instructed to turn it on.

- 1 Connect the DC power cable to the server.

- 2 Connect the other end of the DC power cable to the PDU. Use the supplied clips and screws to secure the plugs.

The following photograph shows the keyed plug of the DC power cable. This plug connects to the PDU:

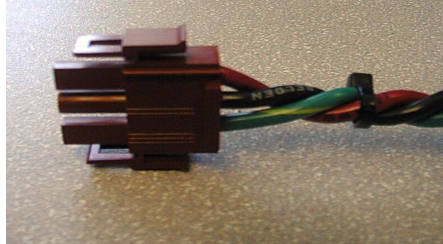

Note: If you are not using a Nortel Networks-supplied PDU, have a qualified electrician connect the cable appropriately to your DC power plant. The 1002rp uses a negative 48 V power supply, therefore the red cable is negative (-48 V) and the black cable is the ground (GND).

- 3 Turn on the PDU.

To start the server

- 1 Press the server power switch to start the server.
- 2 Observe the Power-On Self Test (POST) and initialization messages on the monitor.
- 3 Let the mini-setup sequence run until you are prompted to login to the operating system.

Note: The system may perform multiple reboots. This is normal.

- 4 Ensure that the operating system logon window appears on the monitor.

Note: If the logon window does not appear, refer to the *1002rp Server Maintenance and Diagnostics* (555-7101-206) guide for troubleshooting instructions.

Appendix A

EMC emission level protection for the 1002rp Server

To lower the EMC emission level, ferrite cores are installed with one loop (see diagram below) on the following external cables:

- Ferrite Core (TDK and part number ZCAT3035-1330) — for the triple DS30X I/O cable (Nortel Networks and part number NTRH2014), at each end of the cable
- Ferrite Core (TDK and part number ZCAT1325-0530) — for the modem power supply cable, at each end of the cable
- Ferrite Core (Fair Rite and part number 0431164181) — for the Trenton combined keyboard and mouse Y connector cable, at the server end of the cable
- Ferrite Core (part number WE 742 7111) — for Ethernet port cat5 UTP cable, at the server end of the cable



CAUTION

Risk of equipment damage

The ferrite cores are pre-installed on these customer provided cables. It is not the customer's responsibility to attach these ferrite cores to these cables. However, the customer should ensure that these ferrites are in place to keep the EMC emission levels low.

Ferrites secured to an external cable

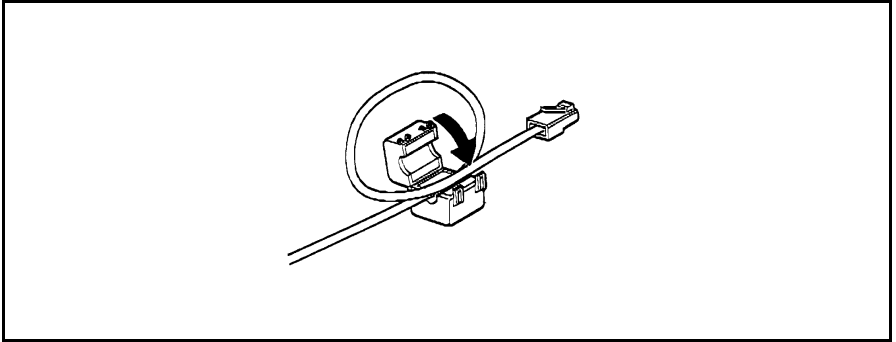

The ferrites are secured to the appropriate cable with plastic enclosure clips. Ty wraps are added to the cable loop.

Index

Numerics

- 703t server
 - environmental specifications 11

A

- adapter
 - software feature key, illustration 67
- alarm board 12

C

- checklist
 - installation 28
- CLAN
 - media access control address 65
- connecting peripherals to the server 59
- connecting the server 69
- connectivity
 - Ethernet 23
 - remote 24
- Customer LAN
 - see CLAN 65

D

- DC power 48
- DC power and ground 51
- DC power input 50
- DC wire gauge tables 44
- devices, peripheral

- Ethernet hub 25
- keyboard 25
- modem 25
- monitor 25
- mouse 25
- diagram
 - connection
 - network, M1 and CallPilot server 21
 - network, Succession 1000 and CallPilot server 22
 - front panel 12
 - PCI and ISA connectors 14
 - rear panel
 - slot locations 13
 - server connections for the power cord and peripherals 59
- DIP switches
 - modem, function 57
- DIP switches, setting
 - modem 57
- dongle 67

E

- ELAN
 - Media Access Control address 62
- environmental specifications, 703t server 11
- equipment
 - unpacking 31
- Ethernet hub
 - description 25

F

- fax modem
 - illustration 56
 - required equipment 55
- features
 - server 10
- features, front panel
 - diagram 12
- front bezel 34

G

- grounding guidelines 44

I

- illustration
 - modem 56
 - software feature key adapter 67
 - TLAN 22
- inspecting
 - server interior 37
- installation checklist 28
- IRQ mapping table 18

K

- keyboard
 - connecting to the server 60
 - description 25
- keylock 67

M

- M1 and CallPilot server network diagram 21
- Metric wire conversion 45
- modem
 - connecting to the server 60
 - description 25

- DIP switches, setting 57
- illustration 56
- required equipment 55
- monitor
 - connecting to the server 60
 - description 25
- mouse
 - connecting to the server 60
 - description 25

N

- network
 - protocols, supported 23
- network interface cards 23

P

- part number
 - Ethernet hub 25
 - keyboard 25
 - modem 25
 - monitor 25
 - mouse 25
- PCI and ISA connectors
 - diagram 14
- PDU 49
 - multiple PDUs 50
 - power and grounding 49
 - single PDU wiring diagram 50
- peripheral devices
 - Ethernet hub 25
 - keyboard 25
 - modem 25
 - monitor 25
 - mouse 25
- peripherals
 - connecting to the server 59
- power connection
 - AC server 71
 - DC server 71
- power distribution rationale 47, 48

power distribution unit

See PDU

power guidelines 44

power supply

bringing power and ground into the PDU
51

DC wire gauge tables 44

grounding guidelines 44

Metric wire conversion 45

module installation 43

module location 41

overview 41

PDU 49

power distribution rationale 48

rack power and grounding 47

protocols, supported network 23

R

rack power and grounding 47

remote access

connectivity 24

removing

front bezel 34

server cover 35

replacing

server cover 38

S

safety information 40

serial number of the server 67

server

connecting peripherals 59

environmental specifications 11

power connection 69

serial number 67

setting

modem DIP switches 57

slot assignments 15

slot definition 15

slot numbering 15

software feature key 67

specifications, environmental 11

Succession 1000 and CallPilot server

network diagram 22

switches, setting DIP

modem 57

T

tables, slot assignment 15

telephony LAN

See TLAN

TLAN

illustration 22

U

unpacking

equipment 31

CallPilot

1002rp Server Hardware Installation

Copyright © 2004 Nortel Networks, All Rights Reserved

Information is subject to change without notice. Nortel Networks reserves the right to make changes in design or components as progress in engineering and manufacturing may warrant.

The process of transmitting data and call messaging between the CallPilot server and the switch or system is proprietary to Nortel Networks. Any other use of the data and the transmission process is a violation of the user license unless specifically authorized in writing by Nortel Networks prior to such use. Violations of the license by alternative usage of any portion of this process or the related hardware constitutes grounds for an immediate termination of the license and Nortel Networks reserves the right to seek all allowable remedies for such breach.

Publication number:	555-7101-205
Product release:	3.0
Document release:	Standard 1.0
Date:	November 2004

Printed in Canada

